



2025

NHBC

Standards

Effective from 1 January 2025





Welcome to the NHBC Standards 2025

Welcome to NHBC Standards 2025.

These new Standards apply to every NHBC registered home whose foundations are begun on or after 1 January 2025, applying throughout the UK unless otherwise stated.

We are committed to continuous improvement of the NHBC Standards with an annual review process that considers feedback from our registered customers, as well as the current regulatory environment, technological advances and changing consumer expectations.

Editorial review

As well as the changes outlined below, these Standards have been subject to an editorial review which includes streamlining clause and sub-clause numbering to support more specific reporting and evaluation of Reportable Items (RIs) and claims information.

New Part 11

With the rise in offsite manufacture and the use of Modern Methods of Construction (MMC) on most traditional-build sites, the 2025 Standards include a new Part 11 on MMC, split into three chapters: general requirements, closed panel systems and volumetric systems. Part 11 has been in development since 2022 involving extensive consultation with a range of industry stakeholders and will help to improve construction quality and better appreciate the necessary competencies associated with MMC.

Technical changes

Around 5% of the clauses in the 2025 Standards have new or updated technical information. Of these, the most significant are:

- **Chapter 3.3** — updates to durability and the requirements for free draining post bases, and service life expectations for non-structural timber components for porches and canopies
- **Chapter 4.4** — enhanced guidance on compressible materials
- **Chapter 5.3** — introduction of clause on drainage under buildings
- **Chapter 5.4** — general update and introduction of commentary concerning free lime/mineral salt leaching and use of anti-lime solutions
- **Chapter 6.1** — improved guidance on check reveals, full fill insulation and further clarification on complex junctions
- **Chapter 7.2** — additional guidance on underlay, sarking board and sheets
- **Chapter 8.1** — clarification on the position of cable securing for access and egress routes, update to the provision of UVHWS discharge pipe terminations
- **Chapter 8.6** — updated guidance in relation to pipe insulation requirements for heating and hot water systems
- **Chapter 9.2** — updated requirements for moisture resistant plasterboard to ceilings

A complete list of all changes is available at nhbc.co.uk/standards.

Our core purpose has always been to raise standards in house building where we are steadfast in our commitment to support our registered builders to deliver the highest possible levels of quality, safety and comfort in the homes they build.

As we continue to embrace new technologies and methods of construction, I hope that you will find these new NHBC Standards a valuable resource.

If you have any questions about these Standards, please liaise with your usual NHBC contact.

Thank you for your continued support.



Steve Wood
Chief Executive Officer

The NHBC Standards are produced by NHBC as guidance solely for our builder customers as to how to interpret the technical requirements in relation to the warranty cover provided by NHBC under its Buildmark, Buildmark Choice, Buildmark Link, Buildmark Solo, Buildmark Connect or any similar product from time to time. It has not been created or intended for distribution or use outside of that purpose. The information contained in the NHBC Standards do not constitute advice and is not to be relied upon by any third party. Nothing in the NHBC Standards is intended to, nor should it be taken to, create any legal or contractual relationship. Any third party who chooses to rely upon the information contained in the NHBC Standards shall do so entirely at their own risk and NHBC accepts no duty of care or liability, however caused, in connection with its use or reliance by any third party.



Contents

Part 1 – Welcome

- Contents
- Contact us
- What's changed

Part 2 – Introduction

- 2.1 The Standards and Technical Requirements

Part 3 – General

- 3.1 Concrete and its reinforcement
- 3.2 Cold weather working
- 3.3 Timber preservation (natural solid timber)

Part 4 – Foundations

- 4.1 Land quality – managing ground conditions
- 4.2 Building near trees
- 4.3 Strip and trench fill foundations
- 4.4 Raft, pile, pier and beam foundations
- 4.5 Vibratory ground improvement techniques
- 4.6 Engineered fill

Part 5 – Substructure, ground floors, drainage and basements

- 5.1 Substructure and ground-bearing floors
- 5.2 Suspended ground floors
- 5.3 Drainage below ground
- 5.4 Waterproofing of basements and other below ground structures

Part 6 – Superstructure (excluding roofs)

- 6.1 External masonry walls
- 6.2 External timber framed walls
- 6.3 Internal walls
- 6.4 Timber and concrete upper floors
- 6.5 Steelwork
- 6.6 Staircases
- 6.7 Doors, windows and glazing
- 6.8 Fireplaces, chimneys and flues
- 6.9 Curtain walling and cladding
- 6.10 Light steel framed walls and floors
- 6.11 Render

Part 7 – Roofs

- 7.1 Flat roofs, terraces and balconies
- 7.2 Pitched roofs

Part 8 – Internal services and low or zero carbon technologies

- 8.1 Internal services
- 8.2 Electrical generating technologies
- 8.3 Space heating systems
- 8.4 Ventilation
- 8.5 LZC hot water systems
- 8.6 Installation and commissioning

Part 9 – Finishes

- 9.1 A consistent approach to finishes
- 9.2 Wall and ceiling finishes
- 9.3 Floor finishes
- 9.4 Finishes and fitments
- 9.5 Painting and decorating

Part 10 – External works

- 10.1 Garages
- 10.2 Drives, paths and landscaping

Part 11 – Modern Methods of Construction

- 11.1 MMC Systems: general requirements
- 11.2 Closed panel systems
- 11.3 Volumetric systems

Contact us

Useful contact information is shown below, should you need to contact us for:

Standards online



The online version of the **NHBC Standards 2025** is freely available to all visitors to the **NHBC website**. Complete with supplementary technical content and further guidance notes, Standards online expands and optimises the NHBC Standards 2025 for use on desktop and mobile devices.

Visit: www.nhbc.co.uk/standards

Contact us



If there is anything else you would like to talk to us about.

Call: 0344 633 1000

Visit our contact us tool:
www.nhbc.co.uk/contact-us or

Write to:

Milton Keynes Office

NHBC, NHBC House, Davy Avenue, Knowlhill, Milton Keynes, Bucks MK5 8FP

Belfast Office

NHBC, Northern Ireland and Isle of Man, Holyrood Court, 59 Malone Road, Belfast BT9 6SA

NHBC Accepts

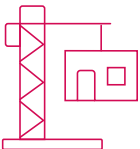

Further guidance on **Modern Methods of Construction (MMC)** can be found at www.nhbc.co.uk/accepts

What's changed

What's changed in NHBC Standards 2025?

We have a new Part 11 for NHBC Standards 2025 plus new or updated technical information affecting around 5% of the total clauses. In addition, we've made improvements to clause and sub-clause numbering which will make recording of Reportable Items and claims information more accurate. There are no changes to Technical Requirements R1 to R5.

Here are the most significant technical changes:

- Part 11 — new section on Modern Methods of Construction incorporating three new chapters: general requirements, closed panel systems and volumetric systems
- Chapter 3.3 — updates to durability and the requirements for free draining post bases and service life expectations for non-structural timber components for porches and canopies
- Chapter 4.4 — enhanced guidance on compressible materials
- Chapter 5.3 — introduction of clause on drainage under buildings
- Chapter 5.4 — general update and introduction of commentary concerning free lime/mineral salt leaching and use of anti-lime solutions.
- Chapter 6.1 — improved guidance on check reveals, full fill insulation and further clarification on complex junctions
- Chapter 7.2 — additional guidance on underlay, sarking board and sheets
- Chapter 8.1 — clarification on the position of cable securing for access and egress routes, update to the provision of UVHWSS discharge pipe terminations
- Chapter 8.6 — updated guidance in relation to pipe insulation requirements for heating and hot water systems
- Chapter 9.2 — updated requirements for moisture resistant plasterboard to ceilings.

As well as minor changes to chapters 3.1, 4.1, 4.2, 4.5, 4.6, 5.1, 5.2, 6.2, 6.3, 6.4, 6.7, 6.8, 6.10, 6.11, 8.6, 9.2

Change tracker

The table below contains a list, in chapter order, of all the technical changes made to NHBC Standards 2025 which apply to every NHBC registered home whose foundations are begun on or after 1 January 2025, applying throughout the UK, unless otherwise stated.

Chapter	Summary of significant changes
Chapter 3.1	<ul style="list-style-type: none"> • 3.1.10 — Additional guidance given relating to lapping mesh reinforcement. • 3.1.14 — Additional text detailing requirements around concrete transportation and site mix concrete placed within 30 minutes. • 3.1.15 — Additional text included around concrete curing during warm weather.
Chapter 3.3	<ul style="list-style-type: none"> • 3.3 — An additional definition of 'solid external wall' has been included following questions about timber requiring treatment when built into solid external walls. • 3.3.2 — Compliance — external timber for uncoated porches and canopies service life reduced to 30 years. External timber components integral to the structure require a 60-year desired service life. • 3.3.2 — Durability — new wording around 150mm from finished ground level or wall finish of piers and free draining post base. Open porch/canopy should not form part of the structure of the home. Where it does, it would require 60-year service life (as per compliance above).
Chapter 4.1	<ul style="list-style-type: none"> • 4.1.7 — Where ground gases are present and cavities need to be sealed, downward moving moisture within the cavity still needs to be removed.
Chapter 4.2	<ul style="list-style-type: none"> • 4.2.10.6 — New guidance added for seasonal events and desiccated soils.
Chapter 4.4	<ul style="list-style-type: none"> • 4.4.9 — Compressible materials — depending on the type of material adopted the thickness should take into account the minimum void required and the residual thickness of the material when compressed.
Chapter 4.5	<ul style="list-style-type: none"> • 4.5.2 — New section on provision of information and NHBC requirements.
Chapter 4.6	<ul style="list-style-type: none"> • 4.6.4 & 4.6.5.2 — Future building foundations should be assessed for effects of 'hardspots'. • 4.6.6.1 — Suitable sources of engineered fill materials — changes and appropriate testing and technical reports to be provided to NHBC. • 4.6.7 Design and specification of earthworks figure 2 amended to be in line with figure 3.
Chapter 5.1	<ul style="list-style-type: none"> • 5.1.4 — Ground conditions — new section on desiccated ground.

Chapter 5.2	<ul style="list-style-type: none"> ● 5.2.10 — Improved guidance for ventilators for timber floors.
Chapter 5.3	<ul style="list-style-type: none"> ● 5.3.7 — Change in pipe size from 1,200mm to 1,350mm on table 4. ● 5.3.17 — Drainage under buildings — Included into NHBC Standards 2025 from Technical Extra 23.
Chapter 5.4	<ul style="list-style-type: none"> ● 5.4.5 — Structural stability — movement — movement joints within the superstructure should be continued into the sub-structure. ● 5.4.7 — Waterproofing systems — Type C — new guidance detailing access points for servicing are considered as well as mineral salt leach effects.
Chapter 6.1	<ul style="list-style-type: none"> ● 6.1.6 — Exposure — severe or very severe locations where building with timber frame require check reveals. ● 6.1.7 — Thermal insulation — guidance enhanced to cover the use of full fill. ● 6.1.11 — Construction of masonry walls — construction — new paragraph on bed and perpendicular joints detailing between 6-15mm in line with tolerances. ● 6.1.12 — Lintels — placing lintels — should be bedded on both leaves to ensure even distribution of loads. ● 6.1.17 — Provision of DPCs and cavity tray — high load DPC over 3 storeys. ● 6.1.17 — Additional guidance for complicated junctions providing that internal and external corners can be site folded where the quality of the fold is of the highest standards.
Chapter 6.2	<ul style="list-style-type: none"> ● 6.2.9 — Fire resistance — text has been moved from section 6.2.4 with additional guidance relating to cavity barriers and design.
Chapter 6.3	<ul style="list-style-type: none"> ● 6.3.9 — Minor revision to deflection head details.
Chapter 6.4	<ul style="list-style-type: none"> ● 6.4.15 — Strutting — performance standard updated to include that strutting shall be provided and where required in accordance with the design. ● 6.4.15 Strutting should be provided along the length of joists at intervals recommended in table 4 and 5.
Chapter 6.7	<ul style="list-style-type: none"> ● 6.7.3 — Clearer guidance relating to checked reveals and removal of 40-year durability requirement.
Chapter 6.8	<ul style="list-style-type: none"> ● 6.8.1 — Compliance clause amended to include a broader term prefabricated chimneys.
Chapter 6.10	<ul style="list-style-type: none"> ● 6.10.4 — Structural design of load-bearing floors and walls — additional support for heavy attachments may be required (boilers, kitchen units, etc).
Chapter 6.11	<ul style="list-style-type: none"> ● 6.11.7 — Detailing diagram amended to show 40mm requirement to drip throat of the coping stone.
Chapter 7.2	<ul style="list-style-type: none"> ● 7.2.14 — Underlay and sarking board and sheets — drape between trusses but not excessive. No drape = counter batten or proprietary spacers for drainage. Penetrations in underlay to be neatly cut or follow manufacturer's guidance. ● 7.2.15 — Ventilation, vapour control and insulation — where BS 5250 cannot be incorporated then a specialist design should be included.
Chapter 8.1	<ul style="list-style-type: none"> ● 8.1.4.5 — Boarded walkways and platforms should have a minimum 50mm clearance between insulation and underside of walkway to ensure ventilation. ● 8.1.6.1 — Cables to be secured where hanging across access and egress routes to not collapse in the event of a fire. ● 8.1.9.3 — Low level discharge arrangements clarified.
Chapter 8.2	<ul style="list-style-type: none"> ● 8.2.1.1. — Clarification of MCS certified products and operative competency. ● 8.2.1.3.6 — Reference to additional requirement in PAS 63100 for the prevention of fire where battery energy storage systems are used.
Chapter 8.6	<ul style="list-style-type: none"> ● 8.6.3 — Updated guidance for pipe insulation to space heating and hot water.
Chapter 9.2	<ul style="list-style-type: none"> ● 9.2.4 — Updated requirements for moisture resistant plasterboard to walls and ceilings in bathrooms and ensuites. ● 9.2.5 — Ceramic wall tiling — change from 3mm for thin bed adhesives and 6mm for thick bed adhesives to +/- 3mm using 2m straight edge. ● 9.2.5 — Ceramic wall tiling, table 11 — changes to the row names for clarity and revised references for guidance relating to the provision of waterproofing systems to bath and shower enclosures.
Chapter 9.3	<ul style="list-style-type: none"> ● 9.3.4 — Included guidance from TGN 9.3/01 relating to fibre reinforced screed needing to have necessary technical assessment for the fibres. ● 9.3.5 — Ceramic, concrete and terrazzo and similar tile finishes — standards relevant to floor finishes include — table 3 — slight wording change to fibre reinforced gypsum tile backer boards subject to assessment.
Part 11	<ul style="list-style-type: none"> ● Complete new Part.



Technical Disclaimer

The NHBC Standards are produced by NHBC as guidance solely for our builder customers as to how to interpret the technical requirements in relation to the warranty cover provided by NHBC under its Buildmark, Buildmark Choice, Buildmark Link, Buildmark Solo, Buildmark Connect or any similar product from time to time. It has not been created or intended for distribution or use outside of that purpose. The information contained in the NHBC Standards do not constitute advice and is not to be relied upon by any third party. Nothing in the NHBC Standards is intended to, nor should it be taken to, create any legal or contractual relationship. Any third party who chooses to rely upon the information contained in the NHBC Standards shall do so entirely at their own risk and NHBC accepts no duty of care or liability, however caused, in connection with its use or reliance by any third party.



NHBC

Part 2

Introduction

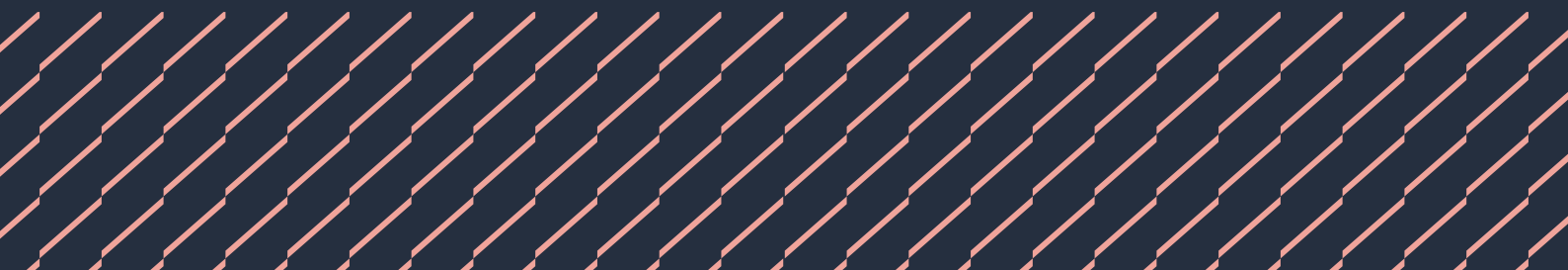



Chapter

2.1



The Standards and Technical Requirements

This chapter introduces the NHBC Standards and contains the Technical Requirements.

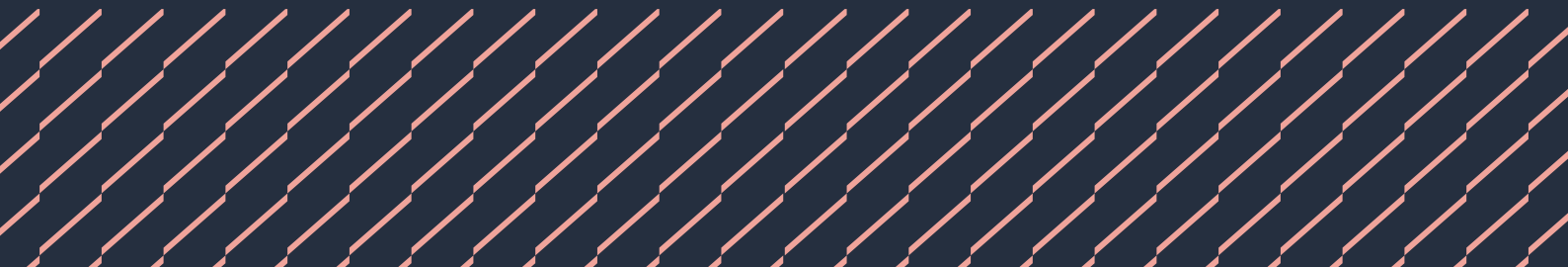

Application of the Standards

The NHBC Standards contain the Technical Requirements, performance standards and guidance for the design and construction of homes acceptable to NHBC. The home is defined in NHBC Rules for builders and developers registered with NHBC. The Standards come into effect for every NHBC registered home whose foundations are begun on or after 1 January 2025, and they apply throughout the UK, unless otherwise stated.

Composition of the Standards

The Standards are divided into 11 Parts, each covering a particular element and subdivided into chapters or sub chapters which, in principle, follow the normal build sequence. The front cover of each chapter contains its scope, together with a list of its contents.

Technical Requirements

The Technical Requirements are shown in **blue text** in this chapter, and **must** be met by the builder.

Performance standards

The performance standards support the Technical Requirements and are shown in bold black text backed with a shaded box. Where the performance standards are followed, the Technical Requirements for that particular item of work will be met. Alternative standards of performance will be acceptable **only** if, in the opinion of NHBC, the Technical Requirements for that particular item of work are met and the standard achieved is not lower than the stated performance standard.

Guidance

Guidance on how the performance standard may be met is shown in black text and is based on normal construction procedures and recommended practices which have been shown to be satisfactory and acceptable over time. NHBC will consider alternative methods to meet specific requirements, subject to prior consultation and evaluation.

Guidance is also contained in illustrations.

Guidance is provided to demonstrate specific technical principles, and should not be used as working construction details.

Limitations on use

The Technical Requirements, performance standards and guidance form acceptable technical benchmarks for a particular item of work, but do not form a complete specification and should not be used as such in contracts. Individual chapters cover, as far as practical, the requirements for particular elements of construction. To avoid repetition, some cross-referencing is made between chapters.

The NHBC Standards do not apply to:

- health and safety matters relating to building operations
- planning matters except where specifically referred to in these Standards.

Such matters are covered by statutory requirements.

Interpretation

Where a difference exists in how to interpret the Technical Requirements, performance standards and guidance, this would generally be resolved by further consultation, failing which, NHBC will exercise its right to decide in accordance with the NHBC Rules.

Testing

Where required, samples of materials, products and systems shall be tested in accordance with Technical Requirement R3 and the NHBC Rules.

Standards and codes of practice

Where NHBC Standards refer to authoritative documents such as British Standards, the documents shall be the editions current at the time of Building Regulation approval, unless other recommendations are agreed by NHBC in writing.

The Standards referred to in the NHBC Standards comprise specifications, codes of practice and published documents that are published by BSI, the European Committee for Standardization (CEN) and the International Organization for Standardization (ISO).

Tolerances

All work shall be within acceptable tolerances. Where applicable, account should be taken of Chapter 9.1 'A consistent approach to finishes'. In other situations, tolerances will be those currently acceptable in the house-building industry.

Acknowledgements

NHBC is indebted to members of the Technical Forum, the Scottish Technical Subcommittee and the Northern Ireland Technical Subcommittee for their work in developing and maintaining the NHBC Standards.

NHBC also wishes to acknowledge the help given by consultants, authoritative organisations, individuals and staff.

Technical Requirements

The Builder shall ensure that the work complies with the Technical Requirements.

R1 Statutory requirements

Work shall comply with all relevant Building Regulations and other statutory requirements relating to the completed construction work.

NHBC will generally accept work that accords with relevant Building Regulations/Building Standards and supporting documents. Exceptions would be where NHBC has a higher standard.

R2 Design requirement

Design and specification shall provide satisfactory performance.

Account shall be taken of:

- a) the land quality, including:
 - i) climate
 - ii) topography
 - iii) geology and ground conditions
 - iv) contamination
 - v) workings below ground
 - vi) previous use of the site
 - vii) any other aspect, on or adjacent to the site, which could affect the design.Where appropriate, the land quality will have to be determined by a person acceptable to NHBC.
- b) the structural adequacy of the works. The design, with appropriate factors of safety, shall satisfactorily allow for loads during and after construction and for their transfer to the supporting structure, or foundation, without undue movement, including:
 - i) self weight
 - ii) all imposed loads, including wind loads
 - iii) construction loads.
- c) the geographical location of the site, including:
 - i) exposure to wind and rain
 - ii) topography.
- d) the position of the dwelling on the site, especially with reference to the dwelling's exposure to the weather, including at early stages in the development of a site, even if it is eventually protected by structures built later.
- e) the position of building elements within the construction works, including the interrelationship of materials and constructions.
- f) the security of the dwellings.

R3 Materials requirement

All materials, products and building systems shall be suitable for their intended purpose.

The structure of the home shall, unless specifically agreed otherwise in writing with NHBC, have a life of at least 60 years. Individual components and assemblies, not integral to the structure, may have a lesser durability and need planned maintenance, repair or replacement during that period.

Account shall be taken of the use and location of materials, products and building systems in relation to:

- durability of both the structure and individual components and assemblies
- geographical location
- position on the site
- position within the structure.

Materials, products and building systems will normally be acceptable if they comply with the following:

- a) **MATERIALS AND PRODUCTS USED FOR CRITICAL FUNCTIONS**
functions critical to performance are: structure, fire resistance, weatherproofing, durability, thermal and sound insulation, services including heating appliances and flues. Any of the following are acceptable:
 - i) performance in accordance with Standards set by NHBC, or
 - ii) where no NHBC Standard is set, compliance with the relevant British Standard or equivalent European Technical Specification approved by a Committee for Standardisation, provided they are used in accordance with the relevant Code of Practice, or
 - iii) compliance with Standards not lower than those defined in a relevant British Standard specification or equivalent, provided their use is accepted by NHBC, or
 - iv) satisfactory assessment by an appropriate independent technical approvals authority accepted by NHBC, or
 - v) use of materials and products in accordance with well established satisfactory custom and practice, provided that such custom and practice is acceptable to NHBC, or
 - vi) acceptance, in writing, by NHBC Accepts.
- b) **MATERIALS AND PRODUCTS USED FOR NON-CRITICAL FUNCTIONS**
compliance with the above acceptance criteria for critical functions or strictly in accordance with manufacturers' recommendations for the specific use.
- c) **RECLAIMED MATERIALS**
reclaimed materials may only be reused with the prior agreement of NHBC. Independent certification of suitability may be required.
- d) **PROPRIETARY BUILDING SYSTEMS**
reference should be made to R3a iv.
- e) **TIMBER DURABILITY**
reference should be made to Chapter 3.3 'Timber preservation (natural solid timber)'.
- f) **RECOVERED AGGREGATES**
aggregates derived from recovered inert waste, eg recycled aggregate, should only be used where it can be demonstrated that the inert waste material has been fully recovered, has ceased to be a waste as defined by the Waste Framework Directive 2008 and has become a product. To this end, recovered aggregates produced by a supplier complying with a recognised defined quality management scheme such as the WRAP Quality Protocol and meeting end-of-waste criteria, will be acceptable to NHBC.

Note

Equivalents to British Standards or technical approvals authority shall be those accepted in the UK.

R4 Workmanship requirement

All work shall be carried out in a proper, neat and workmanlike manner.

The Builder shall ensure that:

- a) the conditions of the materials, products and the completed work are satisfactory
- b) appropriate precautions are taken to prevent damage
- c) account is taken of the following:
 - i) the requirements of the design
 - ii) suitable methods of unloading and handling
 - iii) proper protection during storage
 - iv) use of correct installation methods
 - v) protection against weather during construction (including excessive heat, cold, wetting or drying)
 - vi) protection against damage by following trades.

R5 Structural design requirement

Structural design shall be carried out by suitably qualified persons in accordance with British Standards and Codes of Practice.

The following shall be designed by Chartered Civil or Structural Engineers whose status (including professional indemnity insurance) is accepted by NHBC:

- a) foundations on hazardous ground where the hazard makes special consideration necessary. (Note: This would not apply to matters for which NHBC sets standards, such as building near trees, except where specified to the contrary)
- b) foundations and superstructure of every building over three storeys in height
- c) certain types of foundations and retaining walls, as required in the individual chapters of the NHBC Standards
- d) any structural element which is not based on specific design criteria as laid down in the chapters of the NHBC Standards
- e) any dwelling not constructed in accordance with UK traditional practice.

Note

Other structural elements may be designed by a Chartered Civil or Structural Engineer or others whose status (including professional indemnity insurance) is accepted by NHBC.

The structural design shall take account of the durability requirement in Technical Requirement R3 Materials.

In England, Wales, Northern Ireland and the Isle of Man, structural design may be undertaken by the Builder's own Engineer or a Consulting Engineer employed by the Builder. Where specialist subcontractors undertake the design, it must be separately appraised by the Builder's own Engineer or by a Consulting Engineer employed by the Builder to ensure that the site investigation, choice of foundations, siting and construction of dwellings are properly taken into account and that the design is appropriate for the loading and conditions.

In Scotland, the Engineer shall be independent of the Builder and specialist subcontractor.

Account shall be taken of all parts of the following British Standards:

- Eurocodes and their respective National Annexes
- BS EN 1990. Eurocode 0: 'Basis of structural design'
- BS EN 1991. Eurocode 1: 'Actions on structures'
- BS EN 1992. Eurocode 2: 'Design of concrete structures'
- BS EN 1993. Eurocode 3: 'Design of steel structures'
- BS EN 1995. Eurocode 5: 'Design of timber structures'
- BS EN 1996. Eurocode 6: 'Design of masonry structures'
- BS EN 1997. Eurocode 7: 'Geotechnical design'.

Alternatively, designs in accordance with BS 8103 'Structural design of low rise buildings' will be acceptable.

The Builder shall:

- require the Engineer to issue clear instructions for site personnel
- not permit departure from the design without the Engineer's written consent
- require the Engineer or their representative to carry out such inspections as may be required by NHBC to ensure the adequacy of the design and construction.

The Builder shall ensure that the Engineer visits the site during construction:

- when the foundations have been designed under this Technical Requirement, or
- when specifically required by NHBC in these Standards.

The Engineer shall be satisfied that the design is suitable for the conditions encountered on the site of each dwelling.

When requested by NHBC, the Builder shall:

- produce such design documents, calculations and prescribed forms of certification as NHBC requires for scrutiny
- provide design documents and assembly instructions, solely for the use of NHBC staff
- arrange for NHBC staff to have access to places where off-site fabrication is taking place.



Part 3

General





Chapter

3.1



Concrete and its reinforcement

This chapter gives guidance on meeting the Technical Requirements for concrete and its reinforcement.

3.1.1	Compliance	02
3.1.2	Provision of information	02
3.1.3	Storage of materials	02
3.1.4	Site-mixed concrete	02
3.1.5	Ready-mixed concrete	04
3.1.6	Concrete specification	04
3.1.7	Admixtures	07
3.1.8	Special types of concrete	08
3.1.9	Design of reinforced concrete	08
3.1.10	Installation of reinforcement	09
3.1.11	Blinding concrete	10
3.1.12	Formwork	10
3.1.13	Before concreting	11
3.1.14	Casting	11
3.1.15	Curing	11
3.1.16	Testing	12
3.1.17	Glossary	13
3.1.18	Further information	13



Figure reference table**Figure Reference Table 3.1**

Fig No	Title/Description	Clause	Page
Figure 1	Concrete cover	3.1.9.3	8
Figure 2	Reinforcement layout	3.1.10.1	9
Figure 3	Spacer layout	3.1.10.3	9
Figure 4	Mild steel chair	3.1.10.3	9
Figure 5	Punching shear reinforcement	3.1.10.3	10
Figure 6	Typical punching shear link reinforcement	3.1.10.3	10

Introduction

Concrete design and specification should comply with the relevant British Standards. Mix design should take account of strength and durability, and follow recognised standards and practices. Alternatively, mixes in accordance with the guidance in this chapter will be acceptable. This applies to plain and reinforced concrete, whether precast or in-situ.

3.1.1 Compliance

Also see: Chapter 2.1, BS 8500 and BS EN 206

Concrete and its reinforcement shall comply with the Technical Requirements.

Concrete and its reinforcement that complies with the guidance in this chapter, which covers plain and reinforced concrete, precast or in-situ, will generally be acceptable.

Mix design should take account of strength and durability, and comply with the relevant British Standards.

3.1.2 Provision of information

Designs and specifications shall be produced in a clearly understandable format, include all relevant information and be distributed to appropriate personnel.

Design and specification information should be issued to site supervisors, relevant specialist subcontractors and suppliers, and include the following information:

Ground aggressivity	<ul style="list-style-type: none"> design sulfate class (DS class) 	<ul style="list-style-type: none"> aggressive chemical environment for concrete class (ACEC class)
Strength and durability	<ul style="list-style-type: none"> strength maximum free water/cement ratio and/or minimum cement content consistence class (eg slump) 	<ul style="list-style-type: none"> air content (where required) aggregate size colour
Mix design and additional protective measures (APM)	<ul style="list-style-type: none"> specification of mix designs (concrete strength class) 	<ul style="list-style-type: none"> details of any APM
Reinforcement and movement joints	<ul style="list-style-type: none"> cover to reinforcement reinforcement, plans, sections and bending schedules reinforcement details at supporting edges camber in beams and slabs, where appropriate 	<ul style="list-style-type: none"> reinforcement around openings drawings and bending schedules should be prepared in accordance with BS 8666 movement joints
Formwork	<ul style="list-style-type: none"> formwork materials and features joints 	<ul style="list-style-type: none"> mould release agents holes for services
Finishing treatments	<ul style="list-style-type: none"> concrete to be left untouched or with minimum finishing may require detailed formwork drawings indicating the position and detail of joints between shutters, corners and other critical junctions 	
Testing	<ul style="list-style-type: none"> number and frequency of samples to be taken test laboratory details 	<ul style="list-style-type: none"> recording of results
Curing and protection	<ul style="list-style-type: none"> requirements for curing and striking formwork 	<ul style="list-style-type: none"> minimum period for striking/removal of formwork, curing and protection

3.1.3 Storage of materials

Also see: Chapter 3.2

Materials shall be properly stored to avoid impairing the performance of the finished concrete.

Where materials need to be stored, the following precautions should be taken:

- follow manufacturer's recommendations on maximum storage time
- store cement in a dry place and keep each type separate
- store different sizes of aggregate in separate bays
- keep sand and aggregate clean and dry (allowance should be made in the concrete batching for moisture in the sand and aggregate).

3.1.4 Site-mixed concrete

Site-mixed concrete shall be designed and mixed to ensure sufficient strength and durability.

Concrete should be mixed using an appropriate method to achieve the required strength and durability. Except for very small quantities, a mechanical mixer should be used. Where hand mixing, add an extra 10% of cement to the quantities shown in Tables 2 and 3.

Table 1: Guidance for site-mixed concrete

Material	Guidance
Cement or cementitious material	<ul style="list-style-type: none"> BS 8500-2 2023 including Annexes A and B
Air-entraining admixtures	<ul style="list-style-type: none"> should not be used in standardised prescribed concrete mixes
Admixtures, other than air-entraining admixtures	<ul style="list-style-type: none"> BS EN 934-2
Water	<ul style="list-style-type: none"> mains supply water, or in accordance with BS EN 1008
Aggregates	<ul style="list-style-type: none"> compliant with BS EN 12620 Aggregates for concrete checked and precautions taken when shrinkable aggregates, aggregates susceptible to alkali attack or excessive moisture movement, or unfamiliar materials are used mixed and precautions taken, as described in BRE Digest 357 within the limits of the aggregate carbon range (ACR), when subject to aggressive sulfate ground conditions fine and/or of coarse proportions mixed as specified assessed in accordance with Technical Requirement R3 where materials are recovered or proprietary proportioned to ensure a reasonable consistency, when supplied as a mixture

The information below applies to cement strength class 32.5 and 20mm maximum aggregate size. Where cement strength class 42.5 or higher is used, the cement weight should be decreased by 10%.

Table 2: Mix proportions by weight

Standardised prescribed mix	Consistence class (slump in mm)	Cement (kg)	Fine aggregate (kg)	Coarse aggregate (kg)
ST1	S1 (10-40)	230	770	1,155
ST2	S2 (50-90)	265	760	1,135
ST2	S3 (100-150)	285	735	1,105
ST2	S4 (160-210)	300	815	990
ST3	S2 (50-90)	295	745	1,120
ST4	S2 (50-90)	330	735*	1,100
ST5	S2 (50-90)	375	720*	1,080

* Fine aggregate grading to be grades CP or MP only of BS EN 12620.

Table 3: Mix proportions by volume using a maximum 20mm aggregate size

Cement strength class	Standardised prescribed mix	Consistence class (slump in mm)	Number of (25kg) bags of cement	Fine aggregate (litres)	Coarse aggregate (litres)
32.5	ST1	S1 (10-40)	1	50	80
	ST2	S2 (50-90)	1	45	65
	ST2	S3 (100-150)	1	45*	55
	ST2	S4 (160-210)	1	45*	50
	ST3	S2 (50-90)	1	40	55
42.5 or higher	ST1	S1 (10-40)	1	60	90
	ST2	S2 (50-90)	1	50	75
	ST2	S3 (100-150)	1	50*	65
	ST2	S4 (160-210)	1	45*	60
	ST3	S2 (50-90)	1	45	65

*Fine aggregate grading to be grades CP or MP only to BS EN 12620.

3.1.5 Ready-mixed concrete

Ready-mixed concrete shall be from a supplier operating under a quality control system acceptable to NHBC and be of sufficient strength and durability.

Ready-mixed concrete is acceptable from suppliers who operate under a full quality control scheme such as:

- the Quality Scheme for Ready Mixed Concrete (QSRMC), or
- the BSI Kitemark scheme.

Other suppliers may be suitable if they operate to an equivalent quality standard acceptable to NHBC.

Ready-mixed concrete should be ordered to a detailed specification conforming to BS 8500 and BS EN 206.

When designated mixes are used, the ready-mix supplier will only require the mix designation and consistence class (see Clause 3.1.6 Table 4).

Delivery information should be checked to ensure that the concrete meets the requirements given in the design.

3.1.6 Concrete specification

Also see: BRE Digest 357, BRE Special Digest 1, BS 8500-1, BS 8500-2 and BS EN 206

Concrete shall be specified correctly to ensure adequate strength and durability. Issues to be taken into account include:

- | | |
|--|--------------------------------------|
| 1) concrete in non-hazardous conditions | 5) effects of chlorides |
| 2) exposure to climatic and atmospheric conditions | 6) effects of alkali-silica reaction |
| 3) exposure to aggressive ground conditions | 7) aggregates. |
| 4) exposure to sulfates and acids in groundwater | |

Concrete mixes should be suitable for particular end uses and specified in accordance with BS 8500-1 as either:

- designated mix, which is supplied ready mixed, or
- standardised prescribed mix for site mixing.

Designated mixes should conform to Table 7 of BS 8500-2 2023. Standardised prescribed mixes should conform to Tables 2 and 3 in this chapter.

Mixes should also be designed for the expected conditions of the geographical location of the site and the location of the concrete element in the structure. Higher-grade concrete has greater resistance to chemical and mechanical damage and should be specified accordingly.

In addition to the issues in this section, durability is reliant on:

- correct control of the water:cement ratio
- full compaction of the placed concrete
- good curing.

3.1.6.1 Concrete in non-hazardous conditions

Table 4: Minimum specifications for general purpose concrete mixes

Location and use	BS 8500 and BS EN 206		
	Ready-mixed concrete (designated mix)	Site-mixed concrete (standardised prescribed mix)	Consistence class
Substructure and ground floors <ul style="list-style-type: none"> • rough blinding (non-structural) • infill • unreinforced oversite concrete below timber floors 	GEN1	ST2	S3
<ul style="list-style-type: none"> • structural blinding and over break • strip foundations • trench fill • other mass concrete foundations • fill to wall cavity • solid filling under steps 	GEN1	ST2	S3/S4 ⁽¹⁾
<ul style="list-style-type: none"> • house floors not designed as suspended and not reinforced: <ul style="list-style-type: none"> – permanent finish to be added, eg screed or floating floor – no permanent finish to be added, eg power float finished and carpeted 	GEN1 GEN2	ST2 ST3	S2 S2

Table 4 (continued): Minimum specifications for general purpose concrete mixes

Location and use	BS 8500 and BS EN 206		
	Ready-mixed concrete (designated mix)	Site-mixed concrete (standardised prescribed mix)	Consistence class
<ul style="list-style-type: none"> garage floors not designed as suspended and not reinforced 	GEN3	ST4	S2
<ul style="list-style-type: none"> house and garage ground floor slabs: <ul style="list-style-type: none"> – fully or nominally reinforced, either ground-bearing, suspended or over sub-floor voids 	RC28/35	ST5 ⁽²⁾	S2
Superstructure			
<ul style="list-style-type: none"> general reinforced concrete exposure class⁽³⁾ to BS8500-1: <ul style="list-style-type: none"> – nominal cover to reinforcement of 35mm (which is the minimum cover of 25mm plus an allowance in design for deviation of 10mm) 			
<ul style="list-style-type: none"> a)XC1 (dry) and XC2 (wet, rarely dry) 	RC25/30	⁽⁴⁾	S2
<ul style="list-style-type: none"> b)XC3 (moderate humidity), XC4 (cyclic wet and dry) and XF1 (freeze/thaw attack and no de-icing agent) – nominal cover to reinforcement of 40mm (which is the minimum cover of 30mm plus an allowance in design for deviation of 10mm) 	RC32/40	-	S2
<ul style="list-style-type: none"> c)any exposure class (XC1-4 and XF1) 	RC28/35	⁽⁵⁾	S2
In-situ external concrete			
<ul style="list-style-type: none"> drives and paths 	PAV1	ST5 ⁽⁶⁾	S2
<ul style="list-style-type: none"> bedding for precast concrete paving slabs 	GEN1	ST1	S1

Notes

- Consistence class S3 should be used for strip foundation concrete and consistence class S4 should be used for trench fill foundation concrete.
- ST4 mix for house and garage floors may only be used in conjunction with Chapter 5.2 Suspended ground floors. In all other cases, the designated mix should be used.
- Exposure classes (XC1-4 and XF1) are defined in BS 8500-1 Table A.1.
- In this situation, ST4 mix may be used only for small quantities of concrete. In all other cases, the appropriate designated mix should be used.
- In this situation, an ST5 mix may be used only for small quantities of concrete. In all other cases, the appropriate designated mix should be used.
- Not suitable in areas of severe exposure to frost attack. This is equivalent to exposure class XC4 above.

3.1.6.2 Exposure to climatic and atmospheric conditions

Any concrete mix should be designed for the conditions expected at the geographical location of the site and at the location of the element in the structure.

Table 5: Exposure classes and examples of where they may occur, based on Table 1 of BS EN 206

Exposure class	Environment	Exposure conditions
XC1	Dry or permanently wet	<ul style="list-style-type: none"> concrete inside buildings with low air humidity concrete permanently submerged in water
XC2	Wet, rarely dry	<ul style="list-style-type: none"> concrete surfaces subject to long-term water contact. Many foundations
XC3	Moderate humidity	<ul style="list-style-type: none"> concrete inside buildings with moderate or high air humidity external concrete sheltered from rain
XC4	Cyclic wet and dry	<ul style="list-style-type: none"> concrete surfaces subject to water contact, not within exposure class XC2
XF1	Moderate water saturation, without de-icing agent	<ul style="list-style-type: none"> vertical concrete surfaces exposed to rain and freezing

3.1.6.3 Concrete in aggressive ground

Mixes should conform to BS 8500. The information in this section describes minimum specifications for lower range 'chemical aggressiveness'. Specialist advice should be sought for more aggressive conditions.

Table 6: ACEC site classification⁽¹⁾ and applies to concrete exposed to ground with a pH value greater than 2.5

Sulfate and magnesium				Natural soil		Brownfield ⁽³⁾				ACEC class for site	
Design sulfate class for site	2:1 water/soil extract	Ground water	Total potential sulfate ⁽²⁾	Static water	Mobile water	Static water		Mobile water			
1	2	3	4	5	6	7	8	9	10	11	
	SO ₄	Mg	SO ₄	Mg	SO ₄	pH	pH	pH ⁽⁵⁾	pH ⁽⁵⁾		
	mg/l	mg/l	mg/l	mg/l	%						
DS-1	<500	All Mg values	<400	All Mg values	<0.24	>2.5		>2.5		AC-1s	
							>5.5 ⁽⁶⁾		>6.5	AC-1	
							2.5 -5.5		5.6-6.5	AC-2z	
									4.5-5.5	AC-3z	
									2.5-4.5	AC-4z	
DS-2	500-1500	All Mg values	400-1400	All Mg values	0.24-0.6	>3.5		>5.5		AC-1s	
							>5.5		>6.5	AC-2	
							2.5-3.5		2.5-5.5	AC-2s	
									2.5-5.5	5.6-6.5	AC-3z
										4.5-5.5	AC-4z
					2.5-4.5	AC-5z					

Notes

- For concrete quality and APM for ACEC classes above AC-2z, follow specialist advice. For the full list of ACEC classes, refer to Table A.2 of BS 8500-1 or BRE Special Digest 1 Table C1 for natural ground locations, and Table C2 for brownfield locations.
- Applies only to sites where concrete will be exposed to sulfate ions (SO₄), which may result from the oxidation of sulfides such as pyrite, following ground disturbance.
- Applies to locations on sites that comprise either undisturbed ground that is in its natural state or clean fill derived from such ground.
- 'Brownfield' is defined as sites which may contain chemical residues remaining from previous industrial use or from imported wastes.
- An additional account is taken of hydrochloric and nitric acids by adjustment to sulfate content.
- For flowing water that is potentially aggressive to concrete owing to high purity or an aggressive carbon dioxide level greater than 15mg/l, increase the ACEC class to AC-2z.

Explanation of suffix symbols to ACEC class number:

- suffix 's' indicates that, as the water has been classified as static, no APM are generally necessary
- concrete placed in ACEC classes which include the suffix 'z' have primarily to resist acid conditions and may be made with any of the cements or combinations listed in Table D2 of BRE Special Digest 1.

This table is based on Tables C1 and C2 of BRE Special Digest 1.

The information in Table 7 provides guidance on selecting mixes for concrete elements in aggressive ground.

Table 7: Design guide for concrete elements in the ground

Concrete element	ACEC class ⁽¹⁾	Designated mix
Strip or trench fill foundation, raft foundation, pile ⁽³⁾ and ground beams	AC-1, AC-1s	As Table 4
	AC-2, AC-2s	FND2 ⁽²⁾
	AC-2z	FND2z ⁽²⁾

Notes

- For all other ACEC classes, follow specialist advice.
- Portland limestone cement may only be used where the design sulfate class (see Table 5) of the site does not exceed DS-1.
- Applies to cast-in-situ piles only — for other types of pile refer to BRE Special Digest 1 or follow specialist advice.

3.1.6.4 Exposure to sulfates and acids in groundwater

Sulfates, chemicals and high acidity can cause expansion, cracking and damage to concrete. Where groundwater is highly mobile, or where concrete is at risk from chemical attack, the level of sulfate and other chemicals should be determined according to the ACEC class and BRE Special Digest 1.

For higher ACEC classes, specialist advice should determine the design chemical class (DC class) and appropriate APM where required. Table A.10 of BS 8500-1 should be used to select the mix specification.

For lower ACEC classes (AC-1, AC-1s, AC-2, AC-2s and AC-2z), information in Tables 6 and 7 should be used to select the mix specification.

3.1.6.5 Effects of chlorides

Chlorides, which are contained in all concrete materials, increase the risk of corrosion in metal and can reduce the chemical resistance of concrete. Therefore chloride content of fresh concrete should be limited in accordance with BS EN 206 Table 15.

Cured concrete can be damaged by chlorides in the ground, sea spray or products used for de-icing highways, and specialist guidance should be followed.

3.1.6.6 Effects of alkali-silica reaction

Alkalis can cause expansion, cracking and damage to concrete. Damage can occur when all the following conditions are present:

- a source of alkali
- a high moisture content
- where the aggregate is alkali reactive.

Alkali content calculated in accordance with BRE Digest 330 or Concrete Society Technical Report 30 should not exceed 3kg/m³. Where unfamiliar aggregate materials are used, special precautions may be required.

Standardised prescribed mixes should conform to BS 8500.

3.1.6.7 Aggregates

Aggregates should be of a grade which ensures adequate durability of the concrete. Certain types of aggregate are shrinkable and require special precautions in mixing. Certain types of aggregate may be susceptible to alkali attack or excessive moisture movement.

Proprietary and recovered aggregates should only be specified where they have been assessed in accordance with Technical Requirement R3.

3.1.7 Admixtures

Admixtures shall only be used to enhance the performance and durability of concrete.

Issues that should be taken into account include:

- improved workability
- waterproofing
- foaming agents
- accelerated strength
- retardation
- chlorides.

Admixtures should comply with BS EN 934-2 Admixtures for concrete, mortar and grout — Concrete admixtures — Definitions, requirements, conformity, marking and labelling, should be used in accordance with BS EN 206 and:

- specified only with full knowledge of their limitations and effects
- used only where permitted in the specification
- tested in trial mixes, where necessary
- added to the mix water to ensure complete dispersal
- dosed correctly
- used strictly in accordance with the manufacturer's instructions.

Accelerators produce early setting of the concrete, and plasticisers can improve concrete cohesion and the bond with reinforcement.

Air-entraining agents should not be used as an anti-freeze for fresh concrete. However, they can increase the frost resistance of cured concrete and are recommended for paths, drives and pavements which are likely to be exposed to freezing conditions.

Retarding agents can increase the risk of frost damage.

Admixtures containing chlorides can cause metal corrosion and should not be used in reinforced concrete.

3.1.8 Special types of concrete

Special types of concrete shall be appropriate for their use.

Proprietary concrete, no-fines or lightweight concrete should be of a quality and density appropriate for the conditions and use. Where no-fines concrete is used, a render, cover coat or cladding should be applied to the finished structure.

Proprietary methods of reinforcement, eg glass fibre, should be assessed in accordance with Technical Requirement R3.

Structural design should be in accordance with Technical Requirement R5 and the mix properly detailed.

3.1.9 Design of reinforced concrete

Reinforced concrete shall be suitable for its intended use. Issues to take into account include:

- | | |
|--|--------------------|
| 1) compliance with appropriate standards | 4) fire resistance |
| 2) end restraint | 5) carbonation. |
| 3) concrete cover | |

Reinforced concrete should be designed by an engineer in accordance with Technical Requirement R5. BS 8103-1 can be used for the design of suspended ground floors in homes and garages.

3.1.9.1 Compliance with appropriate standards

The steel specification should indicate the steel type, grade and size. Drawings and bending schedules should be prepared in accordance with BS 8666 and include all necessary dimensions for completion of the sitework. Reinforcement should comply with the standards listed below.

BS EN 1992-1	Design of concrete structures
BS 4449	Steel for the reinforcement of concrete. Specification
BS 4482	Steel wire for the reinforcement of concrete products. Specification
BS 4483	Steel fabric for the reinforcement of concrete. Specification
BS 6744	Stainless steel bars. Reinforcement of concrete. Requirements and test methods
BS 8103-1	Structural design of low-rise buildings. Code of practice for stability, site investigation, foundations, precast concrete floors and ground floor slabs for housing

3.1.9.2 End restraint

Where the ends of slabs are cast monolithically with concrete members, surface cracking may develop over the supports. Reinforcement should therefore be provided in accordance with BS EN 1992-1-1.

3.1.9.3 Concrete cover

There should be adequate cover to the reinforcement, especially where it is exposed or in contact with the ground. Cover should be adequate for all reinforcement, including main bars and stirrups. No ties or clips should protrude into the concrete cover.

For concrete not designed by an engineer, the minimum cover for reinforcement should be in accordance with Table 8.

Figure 1: Concrete cover

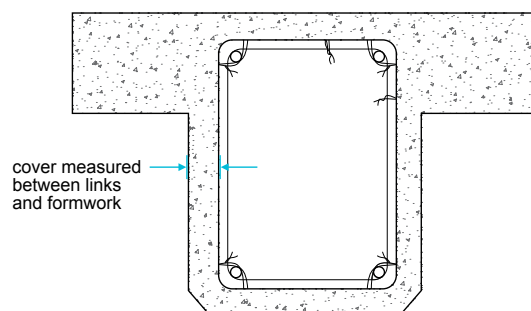

Table 8: Minimum cover for reinforcement for concrete not designed by an engineer

Position of the concrete	Minimum cover (mm)
In contact with the ground	75
External conditions	50
Cast against a DPM on sand blinding	40
Against adequate blinding concrete	40
Protected or internal conditions	25

3.1.9.4 Fire resistance

Concrete cover to reinforcement should be adequate to resist fire. Requirements for fire resistance are given in BS EN 1992-1-2. Cover required by BS EN 1992-1-1 will normally provide up to one hour of fire resistance for columns, simply supported beams and floors.

3.1.9.5 Carbonation

Carbonation reduces the corrosion protection of the reinforcement by increasing porosity and decreasing alkalinity. Such corrosion can be reduced by providing as much concrete cover as possible, and by ensuring that the wet concrete is of good quality and properly compacted to reduce the rate of carbonation.

3.1.10 Installation of reinforcement

Also see: Chapter 5.2

Reinforcement shall be installed in accordance with the design. Issues to take into account include:

- 1) shape, placing and condition of reinforcement bars
- 2) lapping bars and mesh
- 3) support for reinforcement.

3.1.10.1 Shape, placing and condition of reinforcement bars

Main reinforcing bars	Should be parallel to the span, or as detailed in the design
Slab reinforcement	Should be located near the bottom of the slab, with the main reinforcing bars placed first and the secondary bars on top
Beams	Should have the main reinforcing bars placed inside the links

Figure 2: Reinforcement layout

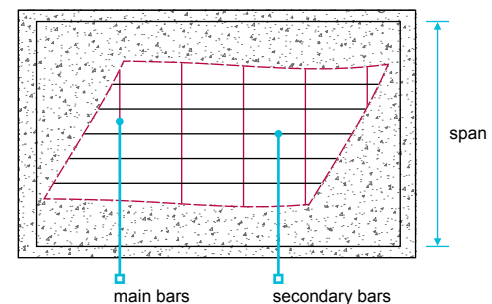

Reinforcement should be:

- bent using appropriate equipment and placed in accordance with the design
- clean and free from loose rust and contaminants, especially shutter-releasing agents and oil.

3.1.10.2 Lapping bars and mesh

Reinforcing bars or mesh should be lapped according to type and size as indicated by the designer to ensure that loads are fully transferred across the lap. Particular care should be taken when lapping mesh reinforcement to ensure both the correct cover is achieved and bars are laid in the correct layers. Depths of cover may need to be increased to accommodate this or use pre-cut sheets with 'flying ends' to avoid nestling or additional loose continuity bars detailed and/or agreed by the designer.

3.1.10.3 Support for reinforcement

Spacers should be either concrete blocks (no more than 50 x 50mm) or ready-made of steel or plastic. Supports should be placed no more than one metre apart, or closer where necessary.

Spacers for parallel bars should be staggered to avoid creating a plane of weakness in the concrete. Supports for top steel should be chairs, or other proprietary products.

Figure 3: Spacer layout

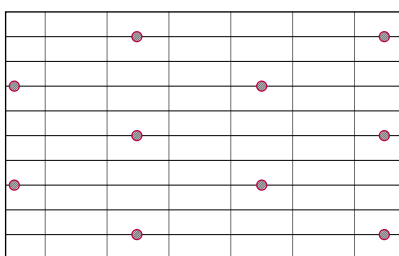

spacers staggered to avoid planes of weakness

Figure 4: Mild steel chair

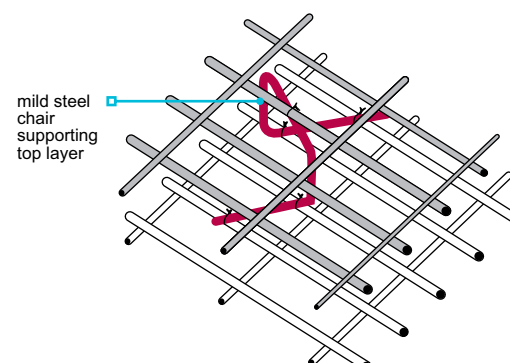

Punching shear reinforcement

Punching shear occurs when a slab is subjected to concentrated forces, for example where a column is offset from a supporting column or columns below and loads must be transferred by the slab.

Design for punching is covered in BS EN 1992-1-1. Where concrete stresses are exceeded, additional reinforcement is locally required. This will either be within the top or bottom (or both) layers of the slab reinforcement and/or be by including shear links joining these layers or additional lacer bars at regular centres around several spaced perimeters about the head or base of columns.

Figure 5: Punching shear reinforcement

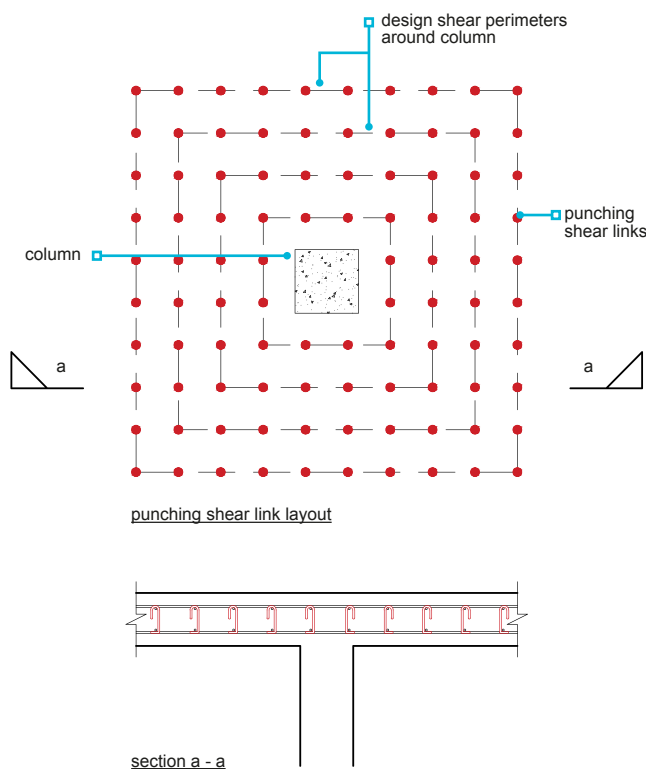

The additional reinforcement will typically be loose bars scheduled to BS 8666 that suit the structural design, with their location, spacing and cover requirements identified on engineers reinforcement detailing drawings. Bars will typically be either straight when included in the top and/or bottom layers, or 'bob-and-hook' or 'U-bars' as shear links.

Figure 6: Typical punching shear link reinforcement

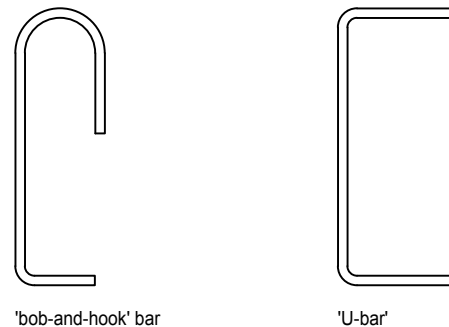

However, there are several proprietary solutions for punching shear reinforcement, and these are commonly used in flat slabs in medium- and high-rise residential buildings. These include stud rail systems, shear ladders and structural steel shear heads, amongst others. These may often be spaced at centres relaxed compared to those required for traditional shear links. Such systems should be:

- independently assessed in accordance with Technical Requirement R3
- assessed according to the intended use
- used strictly in accordance with the manufacturer's recommendations and the independent assessment
- fully detailed and co-ordinated on engineers reinforcement detailing drawings.

3.1.11 Blinding concrete

Blinding concrete shall be used where required to aid construction.

Blinding concrete should only be used:

- to protect the bottom of the trench/excavation where there is a delay in pouring structural concrete
- where the foundation has been slightly over dug
- to provide sufficient support to ensure cover to reinforcement is maintained, or
- where localised soft spots have been removed.

3.1.12 Formwork

Formwork shall be structurally adequate and constructed in a workmanlike manner.

Formwork should be accurately set out in relation to relevant reference lines and benchmarks. Accuracy is essential to ensure that the correct cover to the reinforcement is maintained.

Formwork and its supports should be rigid enough to maintain the correct position and to withstand extra loads and accidental knocks likely to occur during placement and compacting. Wedges, inserts and boxes should be firmly secured to avoid displacement during vibration.

For concrete which is to be left untreated, or with minimum finishing, formwork joints should be tight to avoid grout loss and ragged edges. Joints between shutters should be constructed for easy stripping. Any holes for bolts or spacers should be drilled with care to avoid disfiguring or splintering the formwork surface and giving a poor finish.

Formwork should be capable of being struck without damage to the concrete. Formwork should be dismantled without shock, disturbance or damage to the concrete. Support for load-bearing elements should not be removed until the concrete has achieved sufficient strength, as detailed by the designer. Props under suspended floors or beams should be released from the centre, outwards, to avoid overloading.

3.1.13 Before concreting

Installations and final preparations shall be completed before concreting starts.

Before concreting starts:

- all services, ducts, inserts, etc to be embedded in the concrete should be securely installed in the correct position and, where appropriate, tested
- completed reinforcement should be checked and, where necessary, inspected and accepted by the designer or their representative
- formwork should be cleaned out and checked for fallen debris, especially nails and wire clippings.

3.1.14 Casting

Also see: Chapter 3.2

Concrete shall be cast so as to achieve the required design strength and durability.

The temperature of the concrete at the point of use should not be less than 5°C (41°F). Fresh concrete is susceptible to frost damage, and freezing can cause internal damage that is not immediately obvious.

Concrete should not be placed in or under water, unless it has been specially designed for that use.

Sufficient concrete should be mixed or ordered, so that it can be placed in a continuous process.

Concrete should be placed directly into its final location. Where this is not practicable, it should be deposited close to its final location and transported and placed as fast and efficiently as possible to avoid segregation and to ensure full compaction of the placed concrete.

Site mixed concrete should be placed within 30 minutes, and ready-mixed concrete within the time period recommended by the supplier or required by the specification. Additional water should not be added to ready-mixed concrete unless under the supervision and agreement of the supplier

Concreting should, wherever possible, be carried out in one operation, taking account of:

- weather conditions
- available daylight
- time to allow for surface finishing.

Concrete cast in one operation (ie, without construction joints) should always be as square in shape as possible and not greater than:

- reinforced concrete 60m²
- unreinforced concrete 16m².

Construction joints should be formed only where unavoidable and in consultation with the engineer. These should not be positioned next to a return in the foundation. Before work continues beyond the joint, shuttering used to form the joint should be removed.

Reinforced concrete should be fully compacted using poker vibration unless the design states otherwise. Poker vibration should be carried out by experienced operators to ensure complete coverage and to avoid honeycombing. Vibrating beams or hand tamping may be used to consolidate slabs up to 150mm thick, unless the design details otherwise. Excessive use of vibration can cause segregation and prevent concrete reaching an adequate strength.

3.1.15 Curing

Also see: Chapter 3.2

Concrete shall be adequately cured to achieve full design strength.

Concrete performance relies on the curing process. The design should clearly indicate where there are any special requirements for curing concrete.

Freshly poured concrete should be kept moist by covering as soon as the surface is hard enough to resist damage. This is particularly important in hot, windy or cold weather to prevent the surface drying out too rapidly, or freezing. Damp hessian, damp sharp sand or an impervious sheet (such as polyethylene) are acceptable as surface coverings. Alternatively, a curing agent can be applied to the surface.

In addition when concreting in hot weather (air temperature above 30°C), account should be taken of avoiding reductions in the working life of fresh concrete due to loss of mix water by accelerated hydration and/or evaporation and preventing high temperature rise within the concrete element that could lead to unacceptable levels of early-age thermal cracking, reduction in the ultimate quality of the concrete and delayed ettringite formation (ie, crystallisation that occurs within setting concrete).

However, there are ways in which the concrete can be modified to help counter hot weather effects, such as:

- increasing the initial workability and/or retarding the hydration process using admixtures. Note: a retarder does not compensate for stiffening by moisture loss
- spraying the formwork/base with water before concreting
- using a cement or combination cement that has low heat evolution
- avoiding concreting during the middle of the day when temperatures peak
- specifying a maximum temperature of fresh concrete less than 35°C — see BS 8500-2. Note: temperature of fresh concrete is measured as described in BS EN 12350-1.

Other methods are available, for example pre-cooling the mix constituents and/or the use of embedded cooling pipes (latter only likely to be considered for larger/deeper concrete pours), but these should only be used following specialist's advice.

No load should be applied to the work until the concrete has cured sufficiently. It is recommended that plain unreinforced concrete made with ordinary Portland cement is left for at least four days to cure.

It is possible to proceed with substructure masonry above strip or trench fill foundations on unreinforced ordinary Portland cement concrete at an early stage, provided that care is taken to protect the surface from damage.

Reinforced concrete or concrete containing cement replacements, such as PFA, will require a longer curing period. This will normally take seven days, during which the concrete structure should not be loaded.

Any curing agents should comply with Technical Requirement R3 and should be applied strictly in accordance with the manufacturer's instructions. Curing agents should never be used on floors which are to receive either a topping or a screed, as it could affect the future bond. Curing periods may be extended at low temperatures.

3.1.16 Testing

Testing shall be carried out to the full satisfaction of NHBC.

Testing, where required, shall be conducted to BS EN 12390 by UKAS accredited laboratories. Test cubes should be prepared as requested by the engineer. These should be marked, cured and stored safely until testing.

Proof of testing, with reports, certificates and allied documentation, should be kept for reference and made available to NHBC upon request.

Ready-mixed concrete suppliers should prepare test cubes in accordance with quality assurance procedures.

3.1.17 Glossary

Aggressive chemical environment for concrete classification (ACEC class)	A system for the classification of aggressive ground conditions that are derived from design sulfate class. It takes into account the site (natural or brownfield) and the mobility and pH of groundwater. Brownfield, 'mobile' water and low pH (acidic) conditions may have adverse effects on buried concrete and hence result in a more severe ACEC class.
Additional protective measures (APM)	These are defined as the extra measures that could be taken to protect concrete where the basic concrete specification might not give adequate resistance to chemical attack.
Design chemical class (DC class)	This defines the qualities of concrete that are required to resist chemical attack. The DC class is derived from the ACEC class of the ground and other factors, including the type of concrete element and its required structural performance.
Design sulfate class (DS class)	A site classification based on the determined sulfate (including potential sulfate) contents of the ground and/or groundwater. It is also dependent on the type of site, presence or absence of magnesium ions, pyrite and, for pH less than 5.5, chloride and nitrate ions. Five levels of classification are given that are equivalent to those given in BRE Digest 363 (now superseded).
Enhanced concrete quality	An incremental step in concrete quality that could be used as an Additional Protective Measure (APM). Each increment in concrete quality is counted as an extra APM.
Mobile groundwater	Sites where water is free to flow into an excavation to give a standing water level are affected by mobile groundwater. The threshold ground permeability is greater than 10^{-6} m/s (ie, 86mm/day).
Static groundwater	The sites where the free flow of water is confined due to either permanently dry conditions or the soil being relatively impermeable (of permeability less than 10^{-6} m/s).
Total potential sulfate (TPS)	The total potential sulfate content is the result of the combination of sulfates already present in the ground and that which may be added due to the oxidation of pyrite in the ground.

3.1.18 Further information

- *BRE Digest 357 Shrinkage of natural aggregates in concrete (January 1991)*
- *BS EN 206:2013+A2:2021 Concrete — Specification, performance, production and conformity*
- *BS 8500-1:2023 Concrete — Complementary British Standard to BS EN 206 — Part 1: Method of specifying and guidance for the specifier*
- *BS 8500-2:2023 Concrete — Complementary British Standard to BS EN 206 — Part 2: Specification for constituent materials and concrete*



Chapter

3.2



Cold weather working

This chapter gives guidance on meeting the Technical Requirements for cold weather working.

3.2.1	Compliance	02
3.2.2	External conditions	02
3.2.3	Materials	02
3.2.4	Concreting	02
3.2.5	Masonry	03
3.2.6	Rendering, plastering and screeding	03
3.2.7	Admixtures	04
3.2.8	Painting	04
3.2.9	Further information	04



Figure reference table**Figure Reference Table 3.2**

Fig No	Title/Description	Clause	Page
Figure 1	Protection from frost	3.2.3	2
Figure 2	Protection from frost	3.2.4	2
Figure 3	Protection from frost	3.2.5	3

3.2.1 Compliance

Also see: Chapter 2.1

Cold weather working shall comply with the Technical Requirements.

Sitework which complies with the guidance in this chapter will generally be acceptable.

3.2.2 External conditions

Also see: Meteorological Office

Allowance shall be made for cold weather conditions during construction.

Work should be planned in advance, and account taken of site and climatic conditions either by:

- stopping work, or
- taking adequate precautions.

The following conditions should be considered when scheduling work:

- wind (this can create a cooling effect which can reduce temperatures further ie, affecting the curing of concrete and mortar)
- shade (in particular, high trees or adjacent buildings can block low winter sun and reduce temperatures further)
- valleys (sites in valleys are susceptible to increased risk of frost).

Where air temperature is below, or likely to fall below, 2°C, work should not proceed unless the precautions detailed in this chapter are adopted.

A thermometer should be sited in the shade and used to indicate if temperatures are rising or falling.

3.2.3 Materials

Materials shall be adequately protected against cold weather.

Materials should:

- not be used if frozen
- be protected using appropriate covers to prevent damage by snow, ice, frost or damp.

Appropriate covers should be provided for bricks and blocks, sand, aggregates and cement, to prevent them from becoming saturated and damaged by frost.

Where it is necessary to continue building during longer periods of colder weather, heaters should be used to protect materials.

Figure 1: Protection from frost

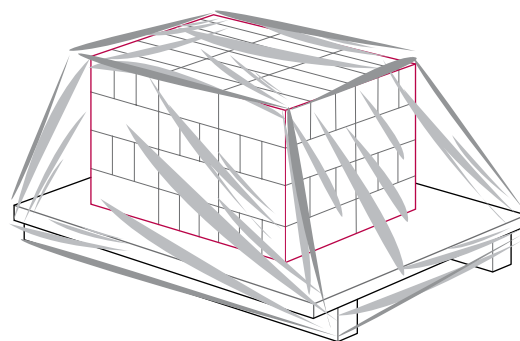

3.2.4 Concreting

Also see: BS EN 13670 & the National Structural Concrete Specification

Concrete shall not be placed in cold weather unless suitable precautions are taken.

The minimum temperature of ready-mixed concrete when delivered should be 5°C, in accordance with BS EN 206.

When concreting is undertaken during colder weather, curing periods should be adjusted according to environmental conditions. Concrete should:

- be covered to maintain the temperature above freezing, and heated if necessary
- not be placed where the ground, oversite or the surfaces that will be in contact with the concrete are frozen
- be placed with caution where small quantities of fresh concrete are against a large volume of hardened concrete which is at a lower temperature.

Figure 2: Protection from frost

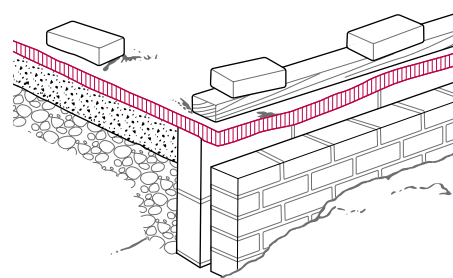

Where slight overnight frosts are expected, 50mm of insulation held down firmly at the edges should be used to help protect oversite concrete. Where very severe frosts are expected, insulation alone is inadequate and heating should be provided.

Site-mixed concrete

If the air temperature drops to 2°C, concrete work should not proceed unless:

- the ground into which the concrete is to be placed is not frozen
- the aggregate temperature is above 2°C
- the aggregate is free of frost and snow
- the water for mixing is heated, but not above 60°C (cement should not be heated)
- the cast concrete can be properly protected, taking account of the cross-sectional area and location.

In prolonged or very severe cold weather:

- covers will not stop severe frost penetrating the aggregate
- where work is to continue, it may be necessary to steam heat aggregates or to use hot air blowers below covers
- heating the mixing water cannot be relied upon to thaw frozen aggregates, and very cold aggregate can still remain frozen.

3.2.5 Masonry

Also see: Chapter 6.1

Masonry shall not be laid in cold weather unless suitable precautions are taken.

When laying masonry in cold weather:

- brickwork and blockwork should not be built when the air temperature is below 3°C and falling
- work can resume when the temperature is 1°C and rising with the expectation the temperature will exceed 3°C
- materials which have been damaged by frost or are frozen should not be used
- additional covers and insulation will be necessary at very low temperatures
- polyethylene covers should be used to provide protection and prevent work from becoming saturated (an air gap between the masonry and the covers will enable new masonry to cure)
- where very severe frosts are expected, heaters may be required
- protection against frost may be required for up to six days, depending on the severity of the conditions.

Figure 3: Protection from frost

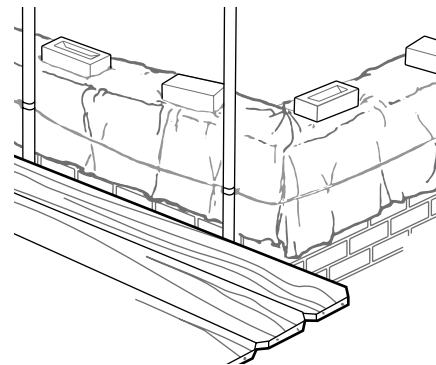
**3.2.6 Rendering, plastering and screeding**

Also see: Chapter 6.11

Rendering, plastering and screeding shall not be carried out in cold weather unless suitable precautions are taken.

Rendering, plastering and screeding should not be carried out if there is frost on the structure.

Where warm air heaters are used to warm the structure before screeding and plastering takes place, they should:

- keep the temperature of the structure above freezing during the curing period
- not produce water vapour (the building should be ventilated to disperse moisture)
- be placed in the room a day before plastering is to start
- be used for longer following a prolonged cold period (as ground floors and walls near to floor level may be slow to respond)
- continue heating for at least 48 hours after completion of the work but not be excessive (to avoid damage to screeds, plaster finishes and woodwork).

Render should not be applied if:

- the temperature is below, or likely to fall below, 2°C (temperatures should be checked throughout the day on a thermometer)
- backgrounds are saturated or frozen, or
- there is a possibility that new work will be subjected to frost before it has set.

3.2.7 Admixtures

Admixtures shall be used correctly and in accordance with the manufacturer's recommendations.

When using admixtures:

- accelerators may assist the mortar or concrete to set before temperatures fall (admixtures do not prevent frost damage to uncured concrete or mortar)
- plasticisers can entrain air during mixing to provide frost resistance to mature mortar and concrete
- in cold weather, retarding agents should not be used as they can increase the setting times of cement
- in cold weather, bonding agents may be ineffective
- those containing calcium chloride should be avoided.

3.2.8 Painting

Also see: Chapter 9.5

Painting shall not be carried out when there is a risk of damage due to cold weather.

Paint should not be applied:

- on surfaces affected by damp, frost or condensation
- where the air temperature is below, or likely to fall below, 2°C
- when condensation, snow or rain is likely to affect paintwork before it is dry.

3.2.9 Further information

- *BS EN 13670:2009 Execution of concrete structures*
- *The National Structural Concrete Specification (4th Edition, April 2010)*



Chapter 3.3



Timber preservation (natural solid timber)

This chapter gives guidance on meeting the Technical Requirements for the protection of natural solid timber against fungal decay and insect attack, dependent upon its use.

3.3.1	Compliance	03
3.3.2	Durability	04
3.3.3	Sitework	07
3.3.4	Protection and storage	07
3.3.5	Treatment of cut surfaces	07
3.3.6	Compatibility with metal	07
3.3.7	Further information	07



Figure reference table**Figure Reference Table 3.3**

Fig No	Title/Description	Clause	Page
Figure 1	Support post base example details	3.3.2	6
Figure 2	Timber reworking terminology	3.3.5	7

Definitions for this chapter

For the purposes of this chapter, the following definitions apply:

Coated/coating	Application of a suitable water-repellent decorative surface coating, such as a paint or stain, which must be maintained over the life of the component. The application of a surface coating should be in addition to the use of factory-applied preservative treatments or timber with adequate natural durability appropriate for the intended application.
Desired Service Life	The period over which a component can function as it was intended. A Desired Service Life is indicative rather than a guarantee of performance and is based on an assumption of good design and maintenance in service.
Durability Class	<p>Durability Classes are systems of determining and classifying durability of wood species or wood-based materials to various wood-destroying organisms based on test methods described in relevant European Standards. Durability Classes are defined in BS EN 350 along with durability ratings of commonly available wood species. The following grade scales are used depending on the destroying organisms:</p> <ul style="list-style-type: none"> • A five-grade scale (Durability Class 1-5) for decay basidiomycete fungi and soft rotting micro-fungi (Table 1 of BS EN 350 and expanded in Table 2 of this chapter) • A two-grade scale (Durability Class D and S) for wood-boring beetles — <i>Hylotrupes bajulus</i>, <i>Anobium punctatum</i>, etc (Table 2 of BS EN 350) • A three-grade scale (Durability Class D, M and S) for termites and marine organisms (Tables 3 and 4 of BS EN 350).
Durability to biological agents	Inherent resistance of a wood species or a wood-based material against wood decay organisms.
Engineered wood products	Engineered wood products such as glue-laminated timber, laminated veneer lumber, I section and metal-web studs, joists and rafters, etc should either have adequate natural durability or be preservative treated following the guidance in this chapter.
Heartwood	Inner zone of wood that, in the growing tree, has ceased to contain living cells or to conduct sap.
Modified wood	<p>Wood modification (not to be confused with preservative treatment) is the industrial processing of timber using thermal or chemical processes to enhance the natural durability of a timber species. Examples of wood modification include thermal treatment (not kiln drying) and acetylation.</p> <p>The modified wood manufacturer should confirm the Durability Class of the product and provide information on its handling, processing and use.</p> <p>Modified wood and modified wood-based materials should be assessed in accordance with Technical Requirement R3.</p>
Preservative treatment	Treatment with a chemical substance to improve resistance to fungal decay and/or wood destroying insects. Application of preservative treatments is an industrial process normally carried out using a combination of pressure and vacuum in a treatment vessel (industrial spray and dip treatments may also be suitable for certain applications). The pressure, duration, formulation, and timber species used will offer varying levels of protection. Further guidance on treatment specifications can be found in BS 8417. Treatment specifications should be suitable for the Use Class and Desired Service Life combinations set out in Table 1.
Sapwood	Outer zone of wood that, in the growing tree, contains living cells and conducts sap. The sapwood of all wood species is considered non-resistant against decay fungi unless other data are available.
Service Class	<p>The Service Class system is intended for use when assigning strength values and calculating deformations under defined environmental conditions for timber components and wood-based materials.</p> <p>A structural engineer will need to specify and consider the Service Class of a timber component when undertaking structural designs and calculations. Further guidance on Service Classes can be found in BS EN 1995-1-1.</p>
Solid external wall	A single leaf of masonry without a cavity forming an external wall.

Use Class	<p>Based on differences in environment exposures that can make wood or wood-based products susceptible to biological deterioration. Table 1 of BS 8417 summarises the Use Class system and gives examples of typical service situations. BS EN 335 contains definitions of use classes which have been summarised below:</p> <ul style="list-style-type: none"> • Use Class 1: situations in which the wood or wood-based product is inside a construction, not exposed to the weather and wetting • Use Class 2: situations in which the wood or wood-based product is under cover and not exposed to the weather (particularly rain and driven rain) but where occasional, but not persistent, wetting can occur. In this Use Class, condensation of water on the surface of wood and wood-based products may occur • Use Class 3: situations in which the wood or wood-based product is above ground and exposed to the weather (particularly rain). A large variety of in-use situations exist and, when relevant, Use Class 3 may be divided into two sub-classes 3.1/3(c) and 3.2/3(uc) • Use Class 3.1/3(c) coated: in this situation, wood and wood-based products will not remain wet for long periods. Water will not accumulate. This may be achieved by, for example, a maintained and suitable coating • Use Class 3.2/3(uc) uncoated: In this situation, wood and wood-based products will remain wet for long periods. Water may accumulate • Use Class 4: a situation in which the wood or wood-based product is in direct contact with ground and/or fresh water.
Wood species	Trade name according to BS EN 13556 which can on occasion include more than one botanical tree species.

Introduction

This chapter sets out Use Classes, Desired Service Life, preservative treatment and natural durability of solid wood components. It does not cover:

- products such as plywood and wood-based particle boards
- the condition before the treatment
- treatment schedules, formulation and process techniques, which is the responsibility of the organisation carrying out the operation.

3.3.1 Compliance

Also see: Chapter 2.1

Timber preservative treatments and processes shall comply with the Technical Requirements and reasonably ensure that the timber is safely and satisfactorily protected against fungal decay and insect attack for the Use Class and Desired Service Life of the component.

Timber and external joinery should either:

- have adequate natural durability against fungal decay and insect attack, or
- be treated with preservative in accordance with BS 8417 and this chapter.

It is important that treatment of timber and joinery is carried out to appropriate standards which are both suitable and safe. Treatments in accordance with procedures set out in British Standards, Codes of Practice, or which have been satisfactorily assessed by an independent authority in accordance with Technical Requirement R3, will generally be acceptable.

The treatment specification should state the:

- component type, and
- Use Class, and
- Desired Service Life.

The treatment specification may also include the timber species, specific treatment and standard required where appropriate.

Preservatives used in England, Scotland and Wales should meet the requirements of The Biocidal Products (Health and Safety) (Amendment) Regulations 2022 or The Control of Pesticides Regulations (1986 as amended) administered by the Health and Safety Executive. Preservatives used in Northern Ireland should be authorised under the EU Biocidal Products Regulation. The safety instructions published by the manufacturers should be followed.

3.3.2 Durability

Also see: BS 8417, BS EN 350, The Wood Protection Association Code of Practice: Industrial Wood Preservation, The Wood Protection Association Wood Selection Guide

Timber and joinery used in the construction of homes shall either have adequate natural durability or, where treatment is undertaken, receive a satisfactory preservative treatment against fungal decay and insect attack.

The natural durability of heartwood varies between wood species. For some end uses, the natural durability of the heartwood of a particular species may provide sufficient durability to be used without preservation. BS EN 350 defines the durability of commonly available wood species, and The Wood Protection Association Wood Selection Guide and BS 8417 provide guidance on natural durability and preservative treatment appropriate for a specific Use Class and Desired Service Life.

Timber component groups and preservative treatment or natural durability requirements are shown in Table 1 below (based on BS 8417), which provides information to establish the appropriate timber Durability Class or requirement for preservative treatment according to the component and conditions of use.

Preservative treatments should be suitable for the Use Class of a component; not all treatment types are suitable for all Use Classes. Guidance on treatment types and schedules can be found in Table 4 of BS 8417 and by consulting treatment manufacturers or The Wood Protection Association.

Table 2 provides information on the timber species and durability of heartwood to protect against attack from fungal decay. Sapwood is generally regarded as not durable, unless proven otherwise by test data.

Table 1: Timber component groups and preservative treatment

Component group	Examples	Use Class	Desired Service Life	Preservative treatment required ⁽¹⁾	Minimum natural Durability Class in lieu of treatment ^(2,10)
Internal joinery	Architraves, skirting boards, internal doors, etc	1	60	X	5
Floor joists	Intermediate floor joists not built into solid external walls, floor boards	1	60	X	5
	Intermediate floor joists built into solid external walls	2	60	✓	2
	Ground floor joists	2	60	✓	2
Roof timbers	All timbers in normal pitched roofs except tiling battens and valley gutter members	1	60	X	5
	Normal pitched roof timbers in areas with house longhorn beetle (Hylotrupes area) ⁽³⁾	1	60	✓	3
	Tiling battens, wood in pitched roofs with high condensation risk ⁽⁴⁾ , wood in flat roofs, pitched valley boards	2	60	✓	2
Timber frame	External wall frame timbers in timber frame housing (including engineered I-studs and metal-web studs), walls forming dormer windows	2	60	✓	2
	Sole plates ⁽⁵⁾	2	60	✓	2
External joinery and cladding (not in ground contact)	Coated external cladding, joinery (windows and doors, including frames), soffits, fascias, barge boards, etc	3.1 3(c)	30	✓	3
	Uncoated external cladding, joinery (windows and doors, including frames), soffits, fascias, barge boards, etc	3.2 3(uc)	30	✓	2

Component group	Examples	Use Class	Desired Service Life	Preservative treatment required ⁽¹⁾	Minimum natural Durability Class in lieu of treatment ^(2,10)
External timber	Coated open porch and canopy structures ⁽¹²⁾ including support posts ⁽⁶⁾	3.1 3(c)	30	✓	3
	Uncoated open porch and canopy structures ⁽¹²⁾ including support posts ⁽⁶⁾	3.2 3(uc)	30	✓	2
	Coated external timber components integral to the structure of the home ⁽¹³⁾⁽⁶⁾	3.1 3(c)	60	✓	2
	Uncoated external timber components integral to the structure of the home ⁽¹³⁾⁽⁶⁾	3.2 3(uc)	60	✓	1
	Deck boards ⁽⁷⁾	3.2 3(uc)	15	✓	3
	Deck posts ⁽⁷⁾ , deck joists and beams ⁽⁷⁾ , external stairs ⁽⁷⁾	4	15	✓	2
	Timber retaining walls up to 1m high within gardens ⁽¹¹⁾	4	15	✓	2
	Timber retaining walls over 1m high within gardens ⁽¹¹⁾ , timber retaining walls up to 600mm high in a boundary situation ⁽¹¹⁾	4	30	✓	1
	Timber retaining walls over 600mm high in a boundary situation ⁽¹¹⁾	4	60	✓ ⁽⁸⁾	1 ⁽⁹⁾

Notes

- Preservative treatment of timber should be in accordance with penetration and retention values listed in Table 4 of BS 8417. It is important to note that not all preservatives are appropriate for all Use Classes and that some timber species are not sufficiently permeable to achieve the penetration levels required, at least without additional processing such as mechanical incising.
- Where natural durability is used in lieu of preservative treatment, timber must be specified and selected as being heartwood only. Durability Classes for the heartwood of commonly used timbers are available in BS EN 350 and summarised in Table 2.
- Any hardwood can be used (subject to adequate structural performance). Recommendations based on evidence that the house longhorn beetle (*H.bajulus*) can attack the heartwood of some softwoods of lower natural durability. Geographic areas where treatment is required are defined in Approved Document A.
- Pitched roofs with a high condensation risk are considered to be roofs over swimming pools, pitched roofs with a fully supported weatherproofing membrane (eg single ply membrane, bituminous membranes, Glass Reinforced Plastic (GRP), etc) or continuous metal coverings, and any other roof system not designed in accordance with BS 5250.
- Sole plates should be positioned above Damp Proof Course (DPC). Preservatives used should be resistant to leaching.
- The base of support posts should be at least 150mm above adjacent ground level, supported on a free draining post base. Where posts are supported on low-level walls, piers or saddle stones, the top of the wall, pier or saddle stone should either have the same footprint as the post or be sloped away from the post, and the base of the post should be supported on a free draining post base at least 150mm above the adjacent ground level; alternatively, where the top of the wall or pier is flat and extends beyond the footprint of the posts, the base of the post should be at least 150mm above the top of the wall, supported on a free draining post base. See Figure 1.
- For decking and external stairs that are more than 600mm and less than 2.4m in height, deck boards, balustrades and external stairs should have a Desired Service Life of 30 years, and deck joists and posts should have a Desired Service Life of 60 years. Reference should be made to Chapter 7.1 Flat roofs and balconies, Chapter 10.2 Drives, paths and landscaping and the Timber Decking and Cladding Association Code of Practice: Raised timber deck structures on new homes. For balconies greater than 2.4m in height, timber is not permitted for gallows brackets, posts, columns, stairs, guardrails or their support, and cantilevered or infill joists (see Clause 7.1.6 for further guidance).
- No generic treatment specifications for a 60-year Desired Service Life in Use Class 4 are provided in either BS 8417 or the WPA Code of Practice for preservative treatments tested to BS EN 599-1, and so specialist advice must be sought from the preservative treatment supplier and/or manufacturer. Due to the potential difficulties in achieving the very high levels of preservative treatment penetration and retention likely required, NHBC requires satisfactory assessment by an appropriate independent technical approvals authority accepted by NHBC for timber components or systems in this scenario.
- Selected woods of natural Durability Class 1 may be able to achieve a Desired Service Life of 60 years (see BS 8417 for further details).
- For modified timber products (such as thermal or chemical modification), guidance on the Durability Class and use of the product should be obtained from the manufacturer.
- Timber retaining structures should not be used to provide support to homes, garages, roads, drives, car parking areas or drainage systems. Further guidance can be found in Chapter 10.2: Drives, paths and landscaping and the Timber Decking.
- An open porch or canopy structure should not form part of the structure of the home, with no timber elements built into the external wall, and be open or without inserts to form an enclosure. The roof over such a porch or canopy structure should not link with the roof over the home.
- Load-bearing parts of the structure that support the weight of higher walls, floors, or roofs, and are essential to the structural stability or strength of the home.

Figure 1: Support post base example details

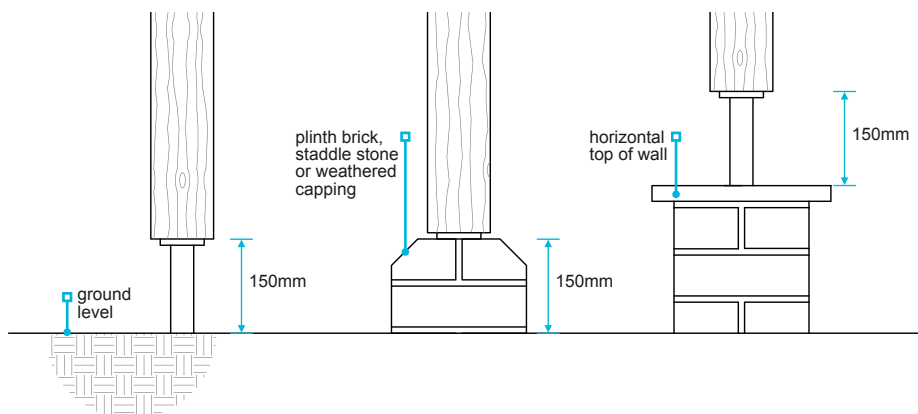

Table 2: Natural durability of building timbers (heartwood only)

Type	Durability Class ⁽¹⁾				
	1 Very durable	2 Durable	3 Moderately durable	4 Slightly durable	5 Not durable
Hardwoods	<ul style="list-style-type: none"> Jarrah Greenheart Okan Angelim, red Cumaru Ipé Padauk (African) Opepe 	<ul style="list-style-type: none"> Oak (European) Meranti (dark red, light red) Oak (American white) Jatoba Ekki Wengé Mahogany (American) Chestnut (sweet) Louro (red) Karri Balau (yellow) 	<ul style="list-style-type: none"> Oak (American red) Walnut (African) Balau (red) 	<ul style="list-style-type: none"> Meranti (yellow) Elm 	<ul style="list-style-type: none"> Chestnut (European horse) Sycamore Alder Birch (yellow, paper, European) Beech (European, silver) Ash (European) Poplar Meranti (white)
	<ul style="list-style-type: none"> Kapur Iroko 		<ul style="list-style-type: none"> Walnut (American, European) Oak (Turkey) Keruing Sapele 		
	<ul style="list-style-type: none"> Teak 				
Softwoods	<ul style="list-style-type: none"> Cedar (Eastern white) 	<ul style="list-style-type: none"> Cedar (yellow) 		<ul style="list-style-type: none"> Pine (Parana, radiata) Spruce (sitka) 	
		<ul style="list-style-type: none"> Cedar (Eastern red, Western red) 	<ul style="list-style-type: none"> Pine (Caribbean pitch, American pitch) Fir (Douglas) Cedar (UK Western red) Larch (European, Japanese, hybrid, Siberian) Pine (lodgepole, maritime, Scots) European Redwood 	<ul style="list-style-type: none"> Spruce (Norway) Pine (Austrian, Corsican, yellow) European Whitewood Hemlock (Western) 	

Note

1. Where a timber species has a range of Durability Classes, and for end uses where durability is important, the lowest Durability Class listed for a wood species should be assumed unless specific source-related information is available.

3.3.3 Sitework

Sitework shall follow established good practice and workmanship.

Checks should ensure that, when timber is delivered to site, timber and joinery products have received the specified treatment. This should be stated on the delivery note and invoice, or a treatment certificate. When buying from stock, always check which Use Class the wood has been treated to.

3.3.4 Protection and storage

Timber and joinery shall be stored and protected to ensure it is in a suitable condition for use.

It is important when timber and joinery products are stored that they are:

- protected from damage immediately upon delivery
- protected from the weather
- stored off the ground
- stored to limit the risk of distortion
- stored to allow air to circulate.

3.3.5 Treatment of cut surfaces

Timber which has been preservative treated and cut shall be re-treated on the cut surfaces.

Timber should not be resawn, ripped or planed after treatment. Reworking should be limited to cross cutting, boring, drilling and notching; reworked surfaces should be re-treated with two liberal brush coats of a suitable preservative recommended by the manufacturer of the industrial wood preservative. To enable confirmation that re-treatment has occurred, a colour tinted preservative should be used; only in situations where colour tinting will affect the appearance of the timber fixed to the home will clear preservative be acceptable.

Figure 2: Timber reworking terminology

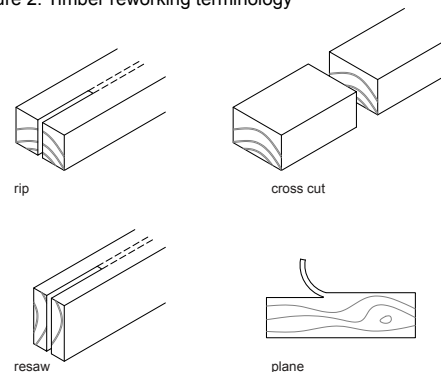

3.3.6 Compatibility with metal

Measures shall be taken to prevent adverse effects from incompatibility between metal components and treated timber.

Copper-containing treatments can cause corrosion between mild steel and aluminium. Where moisture is expected, the following fittings should be used when in contact with timber treated with copper-containing preservatives:

- occasional dampness — galvanised fittings
- likely wetting — austenitic stainless steel fittings.

Preservative treated timber should be re-dried to a moisture content of 22% or less before being in contact with metal fittings.

3.3.7 Further information

- *BS 8417 Preservation of wood. Code of practice*
- *BS EN 599 — Part 1 Durability of wood and wood-based products. Efficacy of preventive wood preservatives as determined by biological tests — Specification according to Use Class*
- *BS EN 350 Durability of wood and wood-based products. Testing and classification of the durability to biological agents of wood-based materials*
- *BS EN 335 Durability of wood and wood-based products. Use Classes: definitions, application to solid wood and wood-based products*
- *The Wood Protection Association Code of Practice: Industrial Wood Preservation (2nd Edition: June 2021)*
- *The Wood Protection Association, Office 5, The Walled Garden, The Nostell Estate, Wakefield West Yorkshire WF4 1AB, Tel: 01977 558274, Email: info@wood-protection.org*



NHBC

Part 4

Foundations



Land quality – managing ground conditions

This chapter gives guidance on meeting the Technical Requirements for assessing and managing land quality.

4.1.1	Compliance	02
4.1.2	Initial Assessment – desk study (all sites)	04
4.1.3	Initial Assessment – walkover survey (all sites)	05
4.1.4	Initial Assessment – results	05
4.1.5	Basic Investigation (sites where hazards are not identified or suspected)	06
4.1.6	Detailed Investigation (sites where hazards are identified or suspected)	06
4.1.7	Managing the risks (sites where hazards are found)	07
4.1.8	Unforeseen hazards	08
4.1.9	Documentation and verification	08
4.1.10	Guidance for investigations	08
4.1.11	Further information	10

Figure reference table**Figure Reference Table 4.1**

Fig No	Title/Description	Clause	Page
Figure 1	Procedure flow chart	4.1.1.3	3

Introduction

This chapter provides a framework for managing geotechnical and contamination risks, with the objective of ensuring that:

- all sites are properly assessed and investigated for potential geotechnical and contamination hazards
- foundations and substructure designs are suitable for the ground conditions
- sites are properly remediated where necessary or appropriate, and design precautions are taken
- appropriate documentation and verification is provided to NHBC.

4.1.1 Compliance

Also see: Chapter 4.2

Assessment of the site and the surrounding area shall comply with the Technical Requirements. Issues to be taken into account include:

- 1) suitability of persons for the level of investigation
- 2) geotechnical and contamination issues
- 3) investigation procedures
- 4) notification in writing to NHBC of hazardous ground conditions.

Ground investigations and management of risk that complies with the guidance in this chapter will generally be acceptable.

4.1.1.1 Suitability of persons for the level of investigation

The following skills and knowledge are required from the person responsible for the Initial Assessment, Basic Investigation and documentation and verification. They should:

- understand the hazards that can affect the development and where they originate
- recognise the signs of potential hazards
- conduct a desk study and walkover survey
- collect information relating to such hazards on and adjacent to the site
- report the findings in a clear and concise manner
- determine when specialist advice and detailed testing is required.

The following criteria should be used as guidance for the appointment of a consultant or specialist responsible for Detailed Investigation, management of hazards, documentation and verification:

Experience	Similar types of site and development
Appropriate discipline(s)	Understanding of all relevant skills required on the project and access to other disciplines, including geologists, hydrogeologists, toxicologists and environmental chemists
Legislation	Understanding of legislation and liabilities associated with the site
Professional indemnity insurance	Appropriate cover for the work being carried out
Health and safety	Awareness of occupational hygiene issues and Health and Safety legislation
Quality assurance	Use of a quality management system, including appropriately accredited laboratories
Project management	Ability to manage a project team consisting of the appropriate disciplines
Site investigation	Ability to design site investigation programmes, including soil sampling, testing and laboratory analysis
Risk management	Ability to conduct risk assessments as required by the risk management process
Reporting and communication	Ability to prepare comprehensive and well-presented reports. Effective communication within their organisation and with the client, statutory authorities and the general public
Engineering design	Understanding of effective risk reduction techniques, eg engineered foundations and substructure details of suitable remediation

4.1.1.2 Geotechnical and contamination issues

Assessment should be carried out by direct investigation and examination of the ground, supplemented by laboratory testing where necessary, in order to determine the geotechnical and contamination characteristics of the site.

Where contamination is suspected or found, the site should be assessed using the Source-Pathway-Receptor framework (known as the pollutant linkage).

For land contamination to occur, a source, pathway and receptor must all exist. A written or diagrammatic representation of the land contamination (known as a Conceptual Model) should be produced to show the possible relationships between each.

4.1.1.3 Investigation procedures

The process to assess and manage the ground conditions is as follows:

Initial Assessment

NHBC requires all sites to be assessed by a desk study and a walkover survey. The results should be used to determine whether or not hazards are known or suspected.

Basic Investigation

Required to support the results of the Initial Assessment where hazards are not suspected.

Detailed Investigation

Required where hazards are known or suspected.

Further Assessment

Required after the Basic or Detailed Investigation has been conducted, to confirm that all objectives have been met. Where results are inconclusive, further investigation will be required.

Hazards

Where hazards are identified, design precautions or remediation will be required to minimise their effects.

If any unforeseen hazards are found during the course of construction, further investigation is likely to be required.

Documentation and verification

NHBC requires documentation and verification to show that:

- the site has been properly assessed and investigated
- where necessary, suitable precautions are incorporated into the design
- all necessary remediation has been carried out.

Figure 1: Procedure flow chart

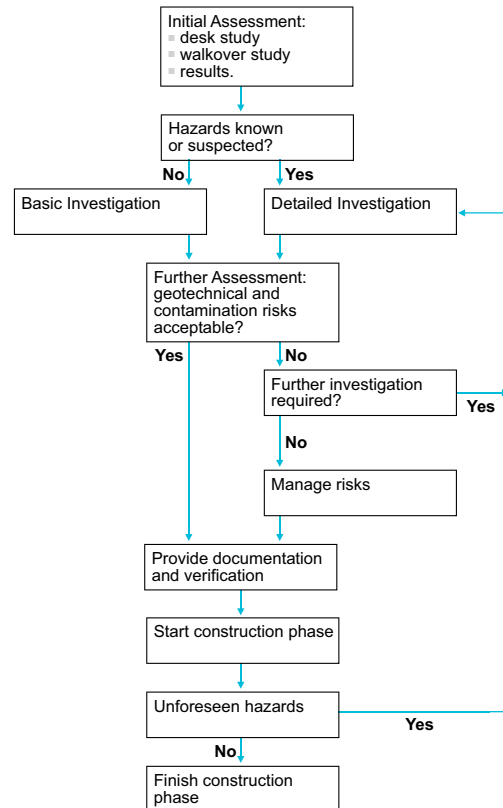

4.1.1.4 Notification in writing to NHBC of hazardous ground conditions

If a site (defined in the NHBC Rules as an area of land that is covered by a single detailed planning consent or series of consents relating to continuous development) is classed as 'hazardous', NHBC must be notified in writing a minimum of eight weeks before work starts. Failure to provide such information may delay the registration process, the construction work and the issuing of NHBC warranty.

Table 1: Potential hazards and associated risks

Potential hazard	Associated risk
High water table or low-lying land	<ul style="list-style-type: none"> flooding the effects from toxic or noxious materials which could be concentrated or transported by groundwater
Mining (past, present and proposed)	<ul style="list-style-type: none"> ground movement as a result of the type of mining and materials extracted ground gases, including methane and carbon dioxide
Trees and vegetation (eg Japanese knotweed or Bamboo — ‘running’ type)	<ul style="list-style-type: none"> shrinkage and heave of clay soils physical damage caused by roots
Peat	<ul style="list-style-type: none"> acid attack changes in volume due to variations in moisture content production of methane and carbon dioxide
Infill and made ground, including tipping	<ul style="list-style-type: none"> release of gases which may be explosive or asphyxiating low bearing capacity causing excessive total and/or differential settlements consolidation characteristics which may result in subsidence, settlement and/or excessive tilt localised ground variability (laterally and with depth) which may result in subsidence, settlement and/or excessive tilt collapse compression or inundation settlement of non-cohesive fills which may result in subsidence, settlement and/or excessive tilt
Low bearing capacity ground	<ul style="list-style-type: none"> settlement of foundations and substructures
Former buildings or structures	<ul style="list-style-type: none"> underground obstructions producing variations in bearing capacity and settlement characteristics
Adjacent buildings	<ul style="list-style-type: none"> effect on stability of both new and existing buildings
Drains, including land drains	<ul style="list-style-type: none"> contamination, flooding, waterlogging and interruption of land drainage systems
Sulfates and sulfides in ground or groundwater	<ul style="list-style-type: none"> expansive reaction chemical attack on concrete, mortar and bricks or blocks made with cement
Contamination	<ul style="list-style-type: none"> from substances which may be carcinogenic, toxic, asphyxiating, corrosive, phytotoxic, combustible, explosive or radioactive
Solution features in chalk, gypsum and limestone, including swallow holes	<ul style="list-style-type: none"> underground cavities
Unstable ground subject to landslip	<ul style="list-style-type: none"> ground movement
Seas, lakes and rivers adjacent to land	<ul style="list-style-type: none"> erosion exposure to saline

4.1.2 Initial Assessment – desk study (all sites)

A desk study of the site and the surrounding area, that covers key and existing site information, shall be undertaken by a suitable person and include investigation of soils, geology, surface water, groundwater, current and historical uses.

A desk study is the collection and examination of existing information obtained from a wide variety of sources. It should indicate potential hazards at an early stage and provide a basis for the investigation. Potential problems should be assessed according to the current and historical uses of the site and surrounding area, including those which may have been left by:

- industrial, commercial and agricultural uses, including storage
- mining
- quarrying
- landfilling and tipping.

Key information sources include:

- Environment Agency or its equivalent — eg coastal erosion, landfill sites, details of water abstraction
- the local authority — eg planning and environmental health
- British Geological Survey, maps and information
- Ordnance Survey, current and previous editions of plans and aerial photographs
- Coal Authority, mining reports — past, present and proposed mining
- utility companies
- county records offices, libraries, museums and local history sources
- soil survey maps
- the site vendor
- in-house information
- ongoing monitoring
- the internet.

4.1.3 Initial Assessment – walkover survey (all sites)

To assess ground conditions, a walkover survey of the site and the surrounding area shall be undertaken by a suitable person.

A walkover survey is a direct inspection of the site and the surrounding area carried out in conjunction with the desk study. Indications of any potential hazards should provide a basis for the investigation. A photographic record of the site can help in the reporting of the walkover survey.

Table 2: Potential hazards

Source of information	Issues to be taken into account
Topography	<ul style="list-style-type: none"> • abrupt changes in slope • valley bottoms or depressions which may be soft or filled • evidence of overburden on slopes • excavations at the base of the slope • signs of landslip, eg tilting trees, posts or walls • signs of subsidence • evidence of imported soil, including local surface depressions, tipped material or rubbish, particularly if it is hot or has an odour
Soils and rocks	<ul style="list-style-type: none"> • the basic ground type • evidence of peat, silt or other highly compressible material at or below the surface • cracking or stickiness of the surface which may indicate a shrinkable subsoil • sudden changes in conditions, eg clay to chalk or soil to rock
Surface water and vegetation	<ul style="list-style-type: none"> • a high water table indicated, eg by waterlogged ground • signs of flooding • reeds or water-loving plants • springs, ponds, wells, ditches or streams • the source of any discoloured water
Vegetation	<ul style="list-style-type: none"> • vegetation which may indicate the nature of the soils • sparse dead or dying vegetation • type and condition of vegetation on land adjoining the site • species, height and condition of the trees • species, height, spread and condition of hedges and scrub on clay • evidence of former trees, hedges or scrub on clay
Structural information	<ul style="list-style-type: none"> • damage to structures, eg cracking in buildings, on or around the site • other evidence of movement, eg tilting or distortion • any structures or services below ground
Local information	<ul style="list-style-type: none"> • local knowledge of the site, eg mining, refuse tipping or flooding • local industrial history records indicating past and present uses of the site • place names and street names that may give clues to previous site usage, eg Brickfield Cottage, Water Lane, Tin Shop Hill

4.1.4 Initial Assessment – results

Also see: BS 5930

The results of the desk study and walkover survey shall be recorded and evaluated by a suitable person.

Initial results should be evaluated for suspected hazards and the results recorded, and include the following as appropriate:

- site plans, including dates, previous and current uses, and proposed site layout
- geology of the site, including geological maps, previous site investigations and laboratory test results
- photographs, including aerial photographs, showing points of interest or concern (eg areas of ground instability), interpretation of aerial photographs, and dates of photographs
- list of sources of information consulted and copies of the information obtained.

4.1.5 Basic Investigation (sites where hazards are not identified or suspected)

Where hazards are not suspected, a Basic Investigation of the site, including geotechnical and contamination investigations, shall be carried out by a suitable person and recorded to the satisfaction of NHBC.

The Basic Investigation aims to provide assurance for all sites, regardless of how free of hazards they may appear, and forms the minimum requirement for a site investigation. Further advice may be found in BS EN 1997-2.

The number and depth of trial pits should be located so they are representative of the site and will depend upon the:

- proposed development
- nature of the site
- inconsistency of the soil and geology across the site.

Trial pits should be located outside the proposed foundation area, and generally be a minimum of 3m deep. The distance from the edge of the foundation should not be less than the depth of the trial pit. Where trial pits do not provide sufficient information, boreholes will be necessary.

Basic geotechnical and contamination investigations should be conducted and include:

- physical tests, such as Plasticity Index tests, to support the results of the Initial Assessment
- a basic contamination investigation based on sampling and testing of soil taken from trial pits during the geotechnical investigation.

During the excavation of the trial pits, the use of sight and smell may help to identify certain contaminants.

If the Basic Investigation reveals the presence of geotechnical and/or contamination hazards, or has not addressed all of the original objectives, or where there is any doubt about the condition of the ground, further Detailed Investigation should be conducted.

4.1.6 Detailed Investigation (sites where hazards are identified or suspected)

Also see: BS 10175

Where hazards are identified or suspected, a Detailed Investigation of the site shall be conducted under the supervision of a consultant or specialist acceptable to NHBC to determine and report on the nature and extent of the conditions.

A Detailed Investigation should be carried out where hazards are identified or suspected:

- from the outset
- from the initial results of the desktop study and walkover survey, or
- from the Basic Investigation.

A consultant or specialist acceptable to NHBC should be appointed to:

- design and supervise the Detailed Investigation
- present all the factual data obtained from the Detailed Investigation.

In addition to the Basic Investigation, the Detailed Investigation should adopt a clearly defined, structured approach, gathering information which considers the:

- immediate site and the adjacent area
- possibility of future development in the vicinity of the site
- nature of the development
- complexity of the ground conditions
- extent of influence of the proposed foundations
- presence of ground gas (if there is any possibility a full gas investigation should be carried out and include flow measurements)
- surface water and groundwater conditions, soils and geology, and site history.

The problems and liabilities which have to be managed in order to develop the site should be clearly communicated in the Detailed Investigation report.

Further investigation should be conducted if the Detailed Investigation has not satisfactorily addressed all of the original objectives.

4.1.7 Managing the risks (sites where hazards are found)*Also see: CIRIA Reports C716 and SP164***Hazardous ground conditions shall be satisfactorily managed under the supervision of a consultant or specialist acceptable to NHBC. Issues to be taken into account include:**

- | | |
|--|---|
| <ul style="list-style-type: none"> 1) design precautions 2) remediation techniques | <ul style="list-style-type: none"> 3) remediation method statement and report. |
|--|---|

The consultant or specialist should:

- identify any results which show that design precautions and/or remediation may be necessary
- conduct a risk assessment to determine appropriate design precautions and/or remedial treatment
- specify the options for remediating any contamination that may be present and provide a remediation method statement
- make recommendations for appropriate design precautions as necessary, including all underground services on the site and any ground improvement techniques
- ensure the works are appropriately supervised
- produce a remediation report.

The proposed solutions for dealing with geotechnical and/or contamination hazards should make due allowance for any constraints that apply, for example:

- factors associated with the site and surrounding area which could restrict the design precautions or remediation techniques should be identified
- local and statutory requirements should be met to avoid abortive works
- time constraints may influence the choice of solution, but do not alter the requirement for effective remediation.

4.1.7.1 Design precautions

Solutions for dealing with geotechnical hazards include:

- specialist foundations such as rafts, pile, pier and beam foundations, see Chapter 4.4 Raft, pile, pier and beam foundations
- vibratory ground improvement techniques, see Chapter 4.5 Vibratory ground improvement techniques
- engineered fill, see Chapter 4.6 Engineered fill.

When dealing with hazardous gases, note:

- some radon barriers and gas membranes are manufactured from recycled products. However, these should not be used. Also see Annex C of BS 8485
- where protective measures are required for both radon and other hazardous gases, eg methane or carbon dioxide, it should not be assumed a radon barrier will be effective in such circumstances and further specialist advice should be sought. Also see Annex G of BS 8485
- on sites where radon or hazardous ground gases are present and cavities need to be sealed, it is still necessary to ensure downward movement of water within cavities is deflected from the cavity to the exterior of the building envelope. To ensure all relevant functional performance requirements of DPCs, cavity trays and gas barriers are met when such site conditions occur, and that products are compatible and detailed to ensure continuity, specialist advice should be sought. Also see, Clause 6.1.17.

4.1.7.2 Remediation techniques

Solutions for dealing with contamination hazards include:

- risk avoidance by changing the pathway or isolating the target, by adjusting the layout and/or by building protective measures into the construction
- engineering-based treatments that remove or isolate contaminants or modify the pathway by excavation, providing ground barriers or covering and capping
- process-based treatment to remove, modify, stabilise or destroy contaminants by physical, biological, chemical or thermal means.

4.1.7.3 Remediation method statement and report

The remediation method statement should detail the strategy for the site and include the:

- original risk assessment, identification of the remediation objectives and outline information for the method chosen
- remediation objectives for ground, groundwater and ground gas
- working method for implementing remediation
- waste classification and methods for control and disposal
- proposed supervision and monitoring of remediation
- validation sampling and testing to be implemented.

The report should include the following information:

- photographic records, especially for work which will be buried (eg membranes)
- site diaries or drawings, environmental supervisor’s site diary and independent witness statements where appropriate
- accurate surveys of the levels and position of all remediated areas
- a description of any remedial materials used
- details of soil movements and waste transfer notes
- results of post-remediation sampling (laboratory certificates should be provided in appendices)
- validation test results
- results of monitoring
- details of all consultations and meetings with statutory authorities.

4.1.8 Unforeseen hazards

Where additional or unforeseen hazards arise during construction, the builder shall ensure investigation and management satisfactory to NHBC.

Where additional or unforeseen hazards arise, specialist advice is required so that the hazard is properly investigated, managed and verified.

4.1.9 Documentation and verification

Documentation and verification shall be provided to the satisfaction of NHBC to demonstrate that the site is suitable for the proposed development. All relevant information, designs, specifications and reports shall be produced in a clearly understandable format and distributed to appropriate personnel.

Where the site is within an area susceptible to radon, it will be necessary to follow appropriate guidance in the relevant Building Regulations and associated documents. The information detailed in Table 3 should be provided to NHBC.

Table 3: Information required by NHBC

Geotechnical hazards present:	Yes	No	Yes	No
Contamination hazards present:	Yes	Yes	No	No
Initial Assessment, Further Assessment and Basic Investigation	•	•	•	•
Detailed Investigation	•	•	•	
Proposals to manage geotechnical risks	•		•	
Proposals to manage contamination risks	•	•		
Verification evidence	•	•	•	•

Note

1. Evidence may still be required by NHBC to substantiate that contamination and hazards are not present on the site.

4.1.10 Guidance for investigations

Site investigations shall be undertaken in accordance with BS EN 1997-2 and recognised practice. Issues to be taken into account include:

- 1) investigation technique
- 2) sampling
- 3) testing.

4.1.10.1 Investigation technique

A site investigation normally comprises techniques which are classed as either indirect or direct. Further advice may be found in BS EN 1997-2.

Indirect investigations use geophysical techniques, including electromagnetic, resistivity, seismic, gravity and ground radar, to interpret ground conditions. Conducted from the surface, they measure variations in properties of the ground, both horizontally and vertically, to define subsurface conditions. Geophysical methods rely on contrasts in the physical properties, for example between sand and gravel and rockhead. Contrast may also be provided by faulting, underground cables and pipelines or by cavities.

Direct investigation techniques involve intrusive activities to enable the retrieval and examination of the ground using trial pits, trenches, boreholes or probes.

Trial pits allow the detailed inspection, logging, sampling and in-situ testing of large volumes of natural soil or fill and the assessment of groundwater conditions. Trenches are extended trial pits, or linked trial pits, which are excavated where greater exposure of the ground conditions is required. Trial pits and trenches should be positioned where they will not affect future foundations.

Boreholes are typically formed using the following techniques:

Light cable percussion drilling	A shell and auger rig — typically used in the UK to drill boreholes in soils and weak rocks
Continuous flight auger	Exploratory boreholes may be drilled in soils by mechanical continuous flight augers of various sizes. Hollow stem methods are typically employed where sample retrieval is required
Rotary drilling	Either open-hole drilling or rotary coring is used to investigate rock and sometimes stiff soils, such as boulder clay
Probing techniques	Used to analyse the relative density of soils and for environmental sampling and monitoring (such as chemical and physical testing of gases, liquids and solids)

4.1.10.2 Sampling

The number and type of samples taken should be:

- appropriate for the results of the desk study, the walkover survey and the site investigation
- appropriate for the range of ground materials encountered and the proposed development
- taken, stored and transported so that they avoid cross contamination.

Samples are used to enable soil and rock descriptions to be made and to provide material for physical and chemical testing.

'Undisturbed' soil and rock samples undergo minimal disturbance, so provide a more reliable indication of the physical soil properties than 'disturbed' samples.

Groundwater should be collected from appropriately designed monitoring wells which should be screened and sealed to ensure that the relevant stratum is being monitored.

Gas sampling should be carried out from appropriately designed monitoring wells. Boreholes or window sampling holes are typically used. Identification of the probable source and the measurement of gas flow are important for risk assessments.

4.1.10.3 Testing

Testing may be undertaken in-situ, or in a laboratory.

A wide variety of in-situ tests can be used to support the results of direct testing. These range from basic tests undertaken by geologists or engineers using simple hand-held devices or portable test kits to methods that require specialist personnel and equipment.

Testing laboratories should participate in quality assurance programmes and be accredited for relevant tests by bodies such as UKAS and MCERTS. Physical tests on soil and rock materials are carried out to provide the following information on ground:

- strength
- relative density
- deformation
- settlement
- consolidation characteristics
- permeability.

Chemical tests on soils, rocks, groundwater and gases can be carried out to provide an indication of potential contamination on the site.

4.1.11 Further information

- BRE: Report BR211 — Radon: Guidance on protective measures for new dwellings (including supplementary advice for extensions, conversions and refurbishment projects)
- BRE: Report BR414 — Protective measures for housing on gas contaminated land
- BRE: Digest 383 — Site investigation for low-rise buildings: Soil description
- BS 5930 — Code of practice for site investigations
- BS 8485 — Code of practice for the design of protective measures for methane and carbon dioxide ground gases for new buildings
- BS 8576 — Guidance on investigations for ground gas — Permanent gases and volatile organic compounds (VOCs)
- BS 10175 — Investigation of potentially contaminated sites
- BS EN ISO 14688 — Geotechnical investigation and testing. Identification and classification of soil: Part 1. Identification and description. Part 2. Principles for a classification
- BS EN ISO 22476 — Geotechnical investigation and testing. Field testing
- CIRIA C665 — Assessing risks posed by hazardous ground gasses to buildings
- CIRIA C682 — The VOCs Handbook. Investigating, assessing and managing risks from inhalation of VOCs at land affected by contamination
- CIRIA C716 — Remediating and mitigating risks from volatile organic compounds (VOC) vapours from land affected by contamination
- CIRIA C735 — Good practice on the testing and verification of protection systems for buildings against hazardous ground gases
- CIRIA C758D — Abandoned mine workings manual
- CIRIA C773 — A guide to small brownfield sites and land contamination
- CIRIA C801 — Hazardous ground gas - a site management guide
- CIRIA SP164 — Remedial treatment for contaminated land, Volumes I - XII
- DLUHC and its predecessor departments' publications
- DEFRA and its predecessor departments' publications
- Environmental Protection Act 1990: Part 2A Contaminated Land Statutory Guidance — April 2012
- Department of the Environment Industry Profiles — Information on the processes, materials and wastes associated with individual industries
- CLEA (Contaminated Land Exposure Assessment) guidance and software Science Reports SR 1, 2, 3 and 7
- NHBC and Environment Agency R&D Publication 66 — Guidance for the safe development of housing on land affected by contamination
- CL:AIRE — Control of Asbestos Regulations 2012: Interpretation for Managing and Working with Asbestos in Soil and Construction and Demolition materials: Industry guidance
- CL:AIRE — Good Practice for Risk Assessment for Coal Mine Gas Emissions
- HSE — Control of Asbestos Regulations 2012
- NHBC Foundation NF94 — Hazardous ground gas — an essential guide for housebuilders
- NHBC/RSK Group Plc Guidance on evaluation of development proposals on sites where methane and carbon dioxide are present Edition No.: 04 March 2007

Building near trees

This chapter gives guidance on meeting the Technical Requirements when building near trees, hedgerows and shrubs, particularly in shrinkable soils.

4.2.1	Compliance	02
4.2.2	Provision of information	02
4.2.3	Building near trees	03
4.2.4	The effects of trees on shrinkable soils	04
4.2.5	Foundations in all soil types	07
4.2.6	Excavation of foundations	07
4.2.7	Foundations in shrinkable soils	07
4.2.8	Design and construction of foundations in shrinkable soils	09
4.2.9	Foundation depths for specific conditions in shrinkable soils	10
4.2.10	Heave precautions	11
4.2.11	New drainage	14
4.2.12	Method of assessment of foundation depths using charts	14
4.2.13	Method of assessment of foundation depths using tables	18
4.2.14	Worked example	24
4.2.15	Further information	26



Figure reference table

Figure Reference Table 4.2

Fig No	Title/Description	Clause	Page
Figure 1	Tree height (H) to be used for particular design cases	4.2.4.2	6
Figure 2	Reductions in foundation depth due to climate variations	4.2.4.3	6
Figure 3	Electronic foundation depth calculator	4.2.7.3	8
Figure 4	Foundations in non-shrinkable soils overlying shrinkable soil	4.2.9.1	10
Figure 5	Levels from which foundation depths are measured where trees or hedgerows are to remain	4.2.9.2	10
Figure 6	Levels from which foundation depths are measured where trees or hedgerows are removed	4.2.9.2	11
Figure 7	Levels from which foundation depths are measured where trees or hedgerows are proposed	4.2.9.2	11
Figure 8	Requirements for raft foundations on shrinkable soils	4.2.9.3	11
Figure 9	Heave precautions for trench fill foundations up to 2.5m deep	4.2.10.4	13
Figure 10	Heave precautions for pier and beam foundations	4.2.10.4	13
Figure 11	Heave precautions for pile and beam foundations	4.2.10.4	13
Figure 12	Layout depicting zones of influence of trees	4.2.14	24

Introduction

The combination of shrinkable soils and trees, hedgerows or shrubs represents a hazard to structures that requires special consideration. Trees, hedgerows and shrubs take moisture from the ground and, in cohesive soils such as clay, this can cause significant volume changes, resulting in ground movement. This has the potential to affect foundations and damage the supported structure. In order to minimise this risk, foundations should be designed to accommodate the movement or be taken to a depth where the likelihood of damaging movement is low.

This chapter gives guidance for common foundation types to deal with the hazard and includes suitable foundation depths which have been established from field data, research, NHBC data and practical experience. The depths are not those at which root activity, desiccation and ground movement are non-existent, but they are intended to provide an acceptable level of risk. However, if significant quantities of roots are unexpectedly encountered in the base of the trench, the excavation may need to be deepened.

The interaction between trees, soil and buildings is dependent on many factors and inherently complex. The relationship becomes less predictable as factors combine to produce extreme conditions. These are signified by the need for deeper foundations. Depths greater than 2.5m indicate that conditions exist where prescriptive guidance is less reliable.

The services of a specialist arboriculturalist may be helpful for the identification of the type and condition of trees that may affect building work. This includes trees both on and adjacent to the site.

Consideration has been given to the potential effects of climate change in the guidance provided.

The following situations are beyond the scope of the guidance in this chapter and will require a site-specific assessment by an engineer (see Technical Requirement R5):

- foundations deeper than 2.5m within the influence of trees
- ground with a slope of greater than 1 in 7 (approximately 8°) and man-made slopes such as embankments and cuttings
- underpinning.

4.2.1 Compliance

Also see: Chapter 2.1

When building near trees, hedgerows or shrubs, all foundations shall comply with the Technical Requirements.

Foundations near trees, hedgerows or shrubs that comply with the guidance in this chapter will generally be acceptable.

4.2.2 Provision of information

Designs and specifications shall be produced in a clearly understandable format, include all relevant information and be distributed to appropriate personnel.

The site plan should show the trees and hedgerows that affect the ground and works, as well as the type, depth and dimensions of the foundations that fall within their influence. Where trees or hedgerows are either not shown or are in different positions, and shrinkable soil is identified, it may be necessary to adjust the foundation depths on site.

All necessary dimensions and levels should be indicated and relate to at least one benchmark and reference points on the site.

Details should be provided with regards to:

- technical method statements
- critical sequences of construction
- site layout
- site investigation
- soil volume change potential
- survey, including location and height of trees and hedgerows affecting the site
- tree species (including existing, removed and proposed) using English names
- original and final ground levels
- planting schedules
- dimensions, type and depth of foundations
- locations and detailing of steps in foundations, movement and construction joints, ducts and services passing through the foundations
- location of services
- design of drainage systems.

4.2.3 Building near trees

Also see: *Technical Requirements R5 and BS 5837*

When building near trees, hedgerows or shrubs, the designs shall take account of:

- 1) physical growth of young trees
- 2) protection of remaining trees and hedgerows
- 3) removal of existing trees and hedgerows.

Before the site is cleared, a survey is required to record the location, heights and species of trees, hedgerows and shrubs on and adjacent to the site, which may affect the proposed development.

If the location of previously removed vegetation is not known, local enquiries and reference to aerial photographs should be carried out. Alternatively, the design should assume the worst conditions, or an engineer consulted to undertake a site-specific design based on all relevant information and in accordance with Technical Requirement R5.

Where root growth is noted within shrinkable soil and where records are not available, an engineer should be consulted to assess whether volume change is likely.

4.2.3.1 Physical growth of young trees

Damage to foundations resulting from the growth of trees and roots should be avoided by locating structures and services at a safe distance. Where this cannot be achieved, precautions which allow for future growth should be taken which include:

- reinforcing foundations to resist lateral forces
- bridging walls or structural slabs over the roots, allowing sufficient clearance or reinforcing to avoid cracking
- laying paving and other surfaces on a flexible base to allow for some movement.

4.2.3.2 Protection of remaining trees and hedgerows

Roots often extend to distances in excess of the height of the tree; the majority are within 600mm of the surface and project radially. All parts of the system are easily susceptible to damage which may not regenerate and which can affect the stability of the tree.

This can be caused by:

- stripping topsoil too close to trees
- excavating trenches for foundations and services too close to trees
- raising soil levels adjacent to trees, particularly where non-granular materials are used
- the compaction of soil around trees by heavy plant
- the storage of heavy materials around trees
- covering the rooting area with impervious surfaces.

Trees should be protected from damage by:

- a fence or barrier. The fence or barrier should extend around a single trunk equivalent to a circle of radius 12 times the trunk diameter, measured 1.5m above ground level. The shape of this area may change depending on specific factors such as local drainage, soil type, age and species of the tree. An arboriculturist may be required to assess these factors
- ensuring services are not routed close to trees or, where this is impractical, are installed in such a way as to minimise root damage.

4.2.3.3 Removal of existing trees and hedgerows

Statutory requirements, planning conditions, conservation area restrictions or tree preservation orders may result in protected trees and hedgerows being retained. The local planning authority should be consulted.

Dead trees and hedgerows should be removed. Unstable trees should be made steady or felled. If necessary, specialist advice should be obtained from a registered arboriculturist.

4.2.4 The effects of trees on shrinkable soils

Foundations shall be designed to make allowance for the effect of trees, hedgerows and shrubs on shrinkable soils. Issues to be taken into account include:

- 1) soil classification, shrinkage and heave
- 2) water demand, tree heights and zone of influence of trees
- 3) climate.

4.2.4.1 Soil classification, shrinkage and heave

Shrinkable soils, which are widely distributed throughout the UK, often change volume as moisture content fluctuates seasonally and as a result of factors including the action of tree roots. The resulting shrinkage or swelling can cause subsidence or heave damage to foundations, the structures they support and services.

The following definitions are used to classify soil properties:

Shrinkable soils	Over 35% fine particles and a Modified Plasticity Index of 10% or greater
Fine particles	Nominal diameter less than 60µm ie, clay and silt particles
Plasticity Index (Ip)	A measure of volume change potential determined by Atterberg Limits tests. These tests are carried out on the fine particles and any medium and fine sand particles. Soil particles with a nominal diameter greater than 425µm are removed by sieving beforehand and the smaller particles analysed. This is a requirement of BS 1377, which specifies the test procedure.
Modified Plasticity Index (I'p)	Defined as the Ip of the soil multiplied by the percentage of particles less than 425µm $I'p = \frac{Ip \times \% \text{ less than } 425\mu\text{m}}{100\%}$

Table 1: Modified Plasticity Index related to volume change potential

Modified Plasticity Index	Volume change potential
40% and greater	High
20% to less than 40%	Medium
10% to less than 20%	Low

Alternatively, the Plasticity Index may be used without modification. For pure clays and other soils with 100% of particles less than 425µm, the result will be the same. However, for mixed soils such as glacial tills, use of the Modified Plasticity Index may result in a more economic design.

The volume change potential should be established from site investigation and reliable local knowledge of the geology. Sufficient samples should be taken to provide confidence that the results are representative. High volume change potential should be assumed if the volume change potential is unknown.

4.2.4.2 Water demand, tree heights and lateral zone of tree influence

Water demand varies according to tree species and size. Water demand categories of common tree species are given in Table 2.

Where the species of a tree has not been identified, high water demand should be assumed.

Where the species of a tree has been identified but is not listed, the assumptions about water demand as listed in Table 2 may be made for broad-leafed trees:

Table 2: Water demand of broad-leaf trees by species

Tree species	Water demand
All elms, eucalyptus, hawthorn, oaks, poplars and willows	High water demand
All others	Moderate water demand

Table 3 shows the water demand categories and the average mature heights to which healthy trees of the species may be expected to grow in favourable ground and environmental conditions. This information:

- should be used for trees that are to remain or are scheduled to be planted
- may be used even when actual heights are greater.

Table 3: Water demand of tree species in relation to their height

High water demand species	Mature height (m)	Moderate water demand species	Mature height (m)	Low water demand species	Mature height (m)
Broad-leaved trees:					
English elm	24	Acacia (False)	18	Birch	14
Wheatley elm	22	Alder	18	Elder	10
Wych elm	18	Apple	10	Fig	8
Eucalyptus	18	Ash	23	Hazel	8
Hawthorn	10	Bay laurel	10	Holly	12
English oak	20	Beech	20	Honey locust	14
Holm oak	16	Blackthorn	8	Hornbeam	17
Red oak	24	Japanese cherry	9	Laburnum	12
Turkey oak	24	Laurel cherry	8	Magnolia	9
Hybrid black poplar	28	Orchard cherry	12	Mulberry	9
Lombardy poplar	25	Wild cherry	17	Tulip tree	20
White poplar	15	Horse chestnut	20		
Crack willow	24	Sweet chestnut	24		
Weeping willow	16	Lime	22		
White willow	24	Japanese maple	8		
		Norway maple	18		
		Mountain ash	11		
		Pear	12		
		Plane	26		
		Plum	10		
		Sycamore	22		
		Tree of heaven	20		
		Walnut	18		
		Whitebeam	12		
Coniferous trees:					
Lawson's cypress	18	Cedar	20		
Leyland cypress	20	Douglas fir	20		
Monterey cypress	20	Larch	20		
		Monkey puzzle	18		
		Pine	20		
		Spruce	18		
		Wellingtonia	30		
		Yew	12		

Tree identification can be assisted by reference to a tree recognition book. Information may be obtained from suitable alternative authoritative sources for trees not listed in this chapter.

When the species is known but the subspecies is not, the greatest height listed for the species should be assumed.

Where hedgerows contain trees, their effect should be assessed separately, and the height of the species likely to have the greatest effect should be used.

Table 3a provides guidance to be used in assessing the effects of trees and their water demand when they are subjected to heavy crown reduction or removal. For trees which have been, or are to be, removed, allowance should be made for the fact that the water demand of a tree varies with its size and rate of growth.

Table 3b, on the other hand, gives the lateral extent of the zone of influence of trees. Any foundation located within these zones will be influenced by the tree and should be designed to meet the requirements of this chapter.

Table 3a: Guidance for factors affecting the mature height and water demand of trees

Influencing factor	Guidance
Heavy crown reduction or pollarding (previously or planned)	The mature height should be used, or a registered arboriculturalist should be consulted to undertake a site-specific assessment.
Removal of trees (previously or planned)	<p>The water demand of a semi-mature tree may be equal to that of a mature tree, but for a sapling or young tree, it will be significantly less.</p> <p>Figure 1: Tree height (H) to be used for particular design cases</p>  <p>Height (H) should be determined in accordance with this diagram when:</p> <ul style="list-style-type: none"> • deriving foundation depths when trees have been removed, based on tree height at the time of removal • checking the appropriate level from which depths should be measured when trees remain and the ground level is increased, based on tree height at time of construction relative to original ground level — see Figure 5 of Clause 4.2.9.2, or • determining if heave precautions are to be provided, based on tree height at time of construction — see Clause 4.2.10.4.

Table 3b: Zone of influence (lateral extent) of trees

Water demand	Zone of influence
High	1.25 x mature height
Moderate	0.75 x mature height
Low	0.5 x mature height

4.2.4.3 Climate

High rainfall reduces moisture deficits caused by trees and hedgerows, while cool, damp weather reduces the rate of water loss from trees, thus reducing the risk of soil movement.

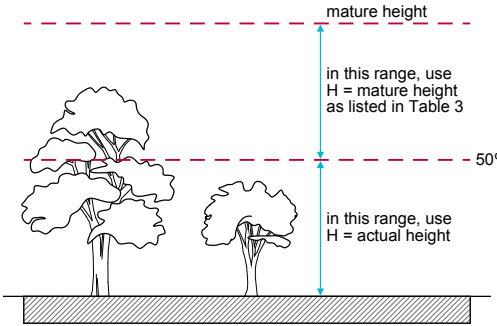
The driest and hottest areas in the UK generally exist in southeast England; therefore, the greatest risk occurs in that area and diminishes with distance north and west. A 50mm decrease can be made to the foundation depth determined in accordance with this chapter for every 50 miles distance north and west of London. Where it is unclear which zone applies, the lower reduction value should be used.

Figure 2: Reductions in foundation depth due to climate variations

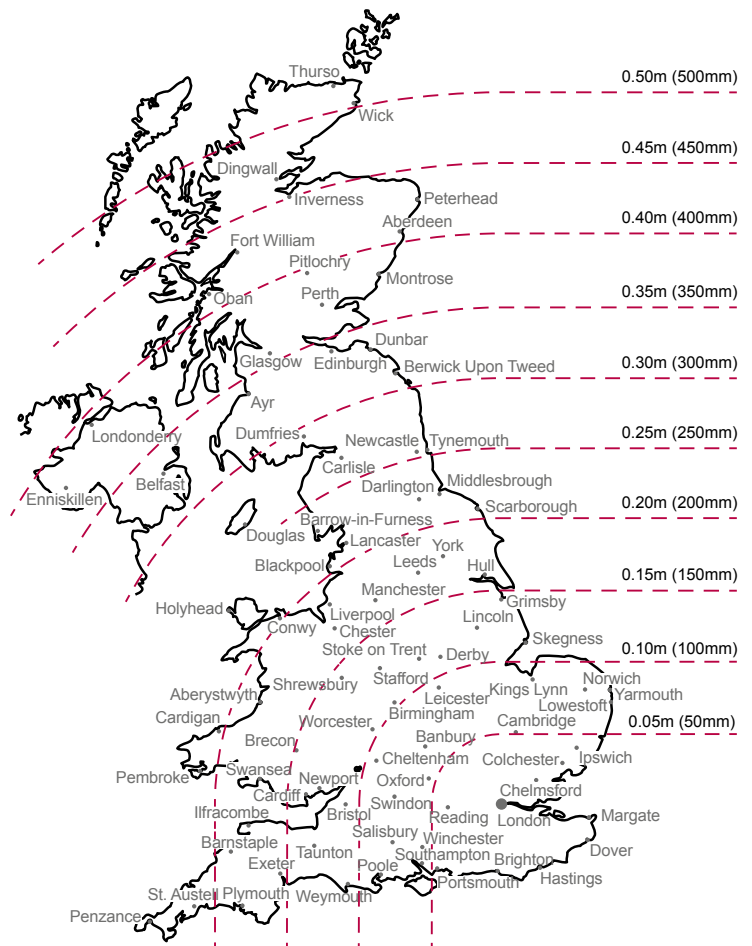

4.2.5 Foundations in all soil types

Foundations in all soil types shall be appropriately designed and constructed to transmit loads to the ground safely and without excessive movement.

Different foundation types should not be used to support the same structure unless the foundation and superstructure design are undertaken by an engineer.

Freestanding masonry walls should be constructed on foundations in accordance with this chapter or designed to accommodate potential ground movement, for example by careful use of movement joints and reinforcement.

4.2.6 Excavation of foundations

Also see: Chapters 4.1, 4.3, 4.4, 4.5 and Technical Requirement R5

Excavation of foundations shall take account of the design and be suitable to receive concrete.

Where trench bottoms become excessively dried or softened due to rain or groundwater, the excavation should be rebottomed prior to concreting.

Foundation depths should be measured on the centre line of the excavation and from ground level determined from Clause 4.2.9.

Some root activity may be expected below the depths determined in accordance with this guidance. However, if significant quantities of roots are unexpectedly encountered in the base of the trench, an engineer should be consulted to determine if the excavation should be deepened.

4.2.7 Foundations in shrinkable soils

Also see: NHBC Foundation Depth Calculator App: www.nhbc.co.uk/apps

Foundations shall be capable of accommodating the effects of trees, shrubs and hedgerows on shrinkable soils without excessive movement. Issues to be taken into account include:

- | | |
|--|--|
| 1) foundation type | 4) foundation depths related to the zone of influence of new tree planting |
| 2) distance between tree and foundation | 5) foundation depths related to new shrub planting. |
| 3) method of assessment of foundation depths | |

Landscape and foundation designs should be compatible, and planting schedules produced by a qualified landscape architect or other suitably qualified person and agreed with the local planning authority before work commences on site.

4.2.7.1 Foundation type

Foundations to all permanent structures, including garages, porches and conservatories, should take account of the effects of soil desiccation. Foundation types that are acceptable in shrinkable soils include strip, trench fill, pier and beam, pile and beam, and raft, providing they:

- are capable of supporting the applied loads without undue settlement
- include suitable heave precautions.

Variations to the foundation depths derived from this chapter may be permitted where:

- it is necessary to take account of local ground conditions
- other foundation depths are traditionally acceptable
- designed in accordance with Technical Requirement R5.

Root barriers are not an acceptable alternative to the guidance given.

4.2.7.2 Distance between tree and foundation

The distance (D) between the centre of the trunk and the nearest face of the foundation should be used to derive the foundation depths.

$D = 2m$ where trees which have been, or are to be, removed from within 2m of the face of the proposed foundation are less than 50% of the mature height as given in Table 3. This is to avoid a situation where, for example, a sapling removed from the foundation line would otherwise require an unnecessarily deep foundation since the D/H value would always be zero, regardless of the height (H) of the tree.

4.2.7.3 Method of assessment of foundation depths

Foundation depths should be determined according to the guidance provided in this document. If in doubt, assume the worst conditions or consult an engineer. Foundations deeper than 2.5m should be designed by an engineer in accordance with Technical Requirement R5.

One of the following methods may be used to assess the foundation depth where foundations are in the zone of influence of existing or proposed trees.

Figure 3: Electronic foundation depth calculator

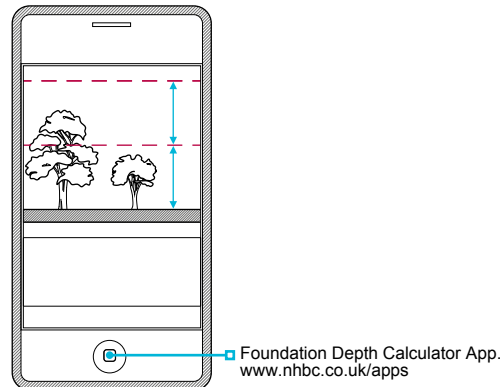

Table 4a: Method of assessment of foundation depths

Method	Taking account of	Comments
Design in accordance with this chapter to a depth derived from the charts in Clause 4.2.12, tables in Clause 4.2.13 or the Foundation Depth Calculator App	<ul style="list-style-type: none"> • site investigation • soil volume change potential • water demand of the tree • appropriate tree height (H) • distance (D) of the tree(s) from the foundations • geographical location of the site north and west of London • appropriate heave precautions 	The most onerous conditions should be assumed in the absence of derived information
Design by an engineer in accordance with Technical Requirement R5	<ul style="list-style-type: none"> • the recommendations of this chapter • site investigation • advice, when necessary, from a registered arboriculturalist or other competent person whose qualifications are acceptable to NHBC 	When this method is used and it results in foundation depths or other details less onerous than those derived from this chapter, the design should be submitted to NHBC prior to work commencing on site

4.2.7.4 Foundation depths related to the zone of influence of new tree planting

Foundation depths relating to the zone of influence of proposed tree planting should be in accordance with any of the following:

- foundation depth charts in Clause 4.2.12
- tables in Clause 4.2.13
- the Foundation Depth Calculator App.

Minimum foundation depths outside of the zone of influence of trees can be determined from Tables 4b and 5.

Table 4b: Minimum foundation depths

Volume change potential	A) Minimum foundation depth (m) (allowing for restricted new planting)	B) Minimum foundation depth (m) (where planting is outside the zone of influence of trees)
High	1.50	1.0
Medium	1.25	0.9
Low	1.0	0.75

Table 5: Where foundation depths are in accordance with column A or column B in Table 4b, tree planting should be restricted to:

Water demand	No tree planting zone for column A in Table 4b	No tree planting zone/zone of influence for column B in Table 4b
High	1.0 x mature height	1.25 x mature height
Moderate	0.5 x mature height	0.75 x mature height
Low	0.2 x mature height	0.50 x mature height

4.2.7.5 Foundation depths related to new shrub planting

Shrubs have considerable potential to cause changes in soil moisture content. The foundation design should consider shrub planting in accordance with Table 6.

Table 6: Shrub planting

Volume change potential	A) Minimum foundation depth (m)	B) Minimum foundation depth (m)
High	1.50	1.0
Medium	1.25	0.9
Low	1.0	0.75

The foundation design should consider shrub planting as follows:

Shrubs that have a maximum mature height of 1.8m	Use foundation depth from column B
Climbing shrubs which require wall support and have a maximum mature height of 5.0m	Use foundation depth from column B
Pyracantha and cotoneaster whose mature height exceeds 1.8m	Use foundation depth from column B and plant at least 1.0 x mature height from foundation, or use foundation depth from column A and plant at least 0.5 x mature height from foundation
All others	Use foundation depth from column B and plant at least 0.75 x mature height from foundation, or use foundation depth from column A with no restriction on minimum distance from foundation

Also see: BRE Digest 298,
Chapters 4.3, 4.4 and
Technical Requirement R5

4.2.8 Design and construction of foundations in shrinkable soils

Foundations in shrinkable soils shall be appropriately designed and constructed.

Reference should be made to Clause 4.2.10 to establish the precautions necessary to cater for potential heave.

The following will only be acceptable if they are designed by an engineer and account for all potential movement of the soil on the foundations and substructure:

- trench fill foundations deeper than 2.5m
- pile and beam foundations
- pier and beam foundations
- rafts.

Trench fill foundations

If trench fill foundations are deeper than 2.5m:

- the instability of the trench sides can lead to serious construction difficulties
- the design should take account of plot-specific soil desiccation and the associated arboricultural advice
- additional heave precautions may be necessary to cater for lateral and shear forces acting on large vertical areas of foundation
- concrete overspill or overbreak in excavations should be avoided in order to reduce the possibility of additional vertical forces being transmitted to the foundation
- compressible material should be correctly placed to avoid excessive heave forces being applied to the foundations
- construction joints need to be detailed to account for increased lateral forces.

Pier and beam foundations

Pier depths not exceeding 2.5m depth may be derived from Clause 4.2.7. Pier depths greater than 2.5m require site-specific assessment.

Pile and beam foundations

When selecting and designing pile and ground beam foundations, piles should be:

- designed with an adequate factor of safety to resist uplift forces on the shaft due to heave
- reinforced for the length of the member governed by the heave design.

Sufficient anchorage should be provided below the depth of desiccated soil. Slip liners may be used to reduce uplift, but the amount of reduction is small, as friction between materials cannot be eliminated.

Bored, cast-in-place piles are well suited to counteracting heave. Most types have a straight-sided shaft, while some are produced with a contoured shaft to increase load capacity. The design should allow for the enhanced tensile forces in these piles.

Driven piles are less well suited to counteracting heave and are difficult to install in stiff desiccated clay without excessive noise and vibration. The joint design of these piles should be capable of transmitting tensile heave forces.

Ground beams should be designed to account for the upward forces acting on their underside and transmitted from the compressible material or void former prior to collapse, and in accordance with the manufacturer's recommendations.

Raft foundations

Raft foundations in shrinkable soils will only be acceptable where all of the following apply:

- design is by an engineer in accordance with Technical Requirement R5
- NHBC is satisfied that the raft is sufficiently stiff to resist differential movements
- NHBC is satisfied that the raft is founded on granular infill placed and fully compacted in layers and in accordance with the engineer’s specification. Where required by NHBC, site inspections are to be undertaken by the engineer to verify suitable compaction of the fill
- the raft is generally rectangular in plan with a side ratio of not more than 2:1
- foundation depth is derived in accordance with Clause 4.2.7, and is less than 2.5m.

4.2.9 Foundation depths for specific conditions in shrinkable soils

Foundations in shrinkable soils shall be designed to transmit loads to the ground safely and without excessive movement. Issues to be taken into account include:

- 1) strip and trench fill foundations in non-shrinkable soils overlying shrinkable soil
- 2) measurement of foundation depths
- 3) granular infill beneath raft foundations in shrinkable soils
- 4) steps in foundations.

4.2.9.1 Strip and trench fill foundations in non-shrinkable soils overlying shrinkable soil

Non-shrinkable soils such as sand and gravel may overlie shrinkable soil. Foundations may be constructed on overlying non-shrinkable soil if all the following are satisfied:

- conditions of Chapter 4.3 Strip and trench fill foundations are met
- consistent soil conditions exist across each plot, and this is confirmed by the site investigation
- depth of the non-shrinkable soil is greater than $\frac{3}{4}$ foundation depth X, where X is the foundation depth determined using charts in Clause 4.2.12, tables in Clause 4.2.13 or the Foundation Depth Calculator App, assuming all the soil is shrinkable
- the thickness T of non-shrinkable soil below the foundation is equal to, or more than, the width of the foundation B, Figure 4
- proposals are submitted to, and approved by, NHBC prior to work commencing on site.

Figure 4: Foundations in non-shrinkable soils overlying shrinkable soil

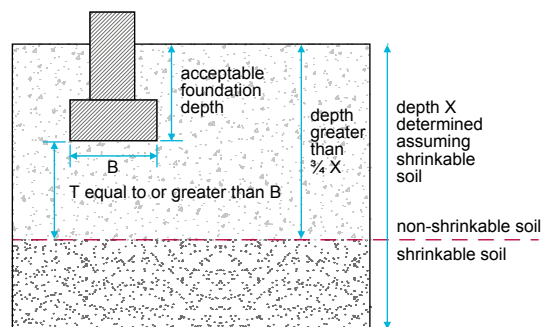

Where any of the above are not met, foundation depths should be determined as for shrinkable soil.

4.2.9.2 Measurement of foundation depths

Where ground levels are to remain unaltered, foundation depths should be measured from original ground level.

Measurement of foundation depths where ground levels are reduced or increased, either in the recent past or during construction, should be as shown in Figures 5, 6 and 7.

Figure 5: Levels from which foundation depths are measured where trees or hedgerows are to remain

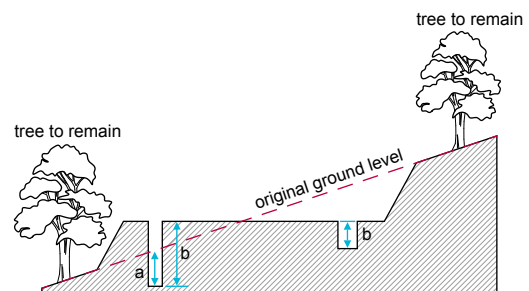

Use the lower of:
a) foundation depth based on appropriate tree height (see Table 3a)
b) foundation depth based on mature height of tree.

Figure 6: Levels from which foundation depths are measured where trees or hedgerows are removed

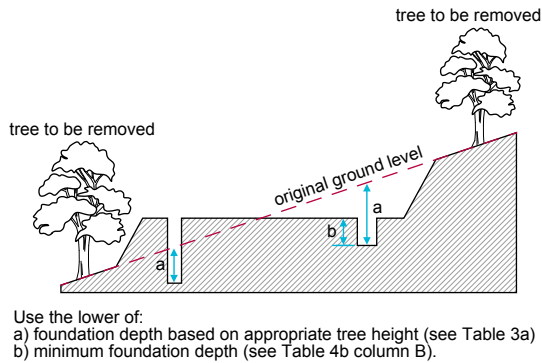
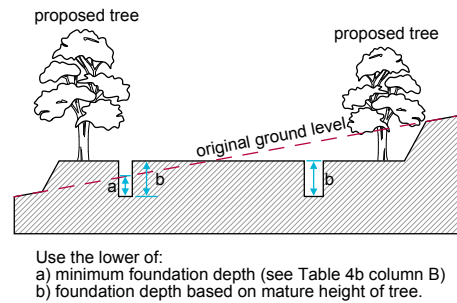

Figure 7: Levels from which foundation depths are measured where trees or hedgerows are proposed



4.2.9.3 Granular infill beneath raft foundations in shrinkable soils

Granular infill together with raft slab foundations can be used as an alternative to deep trench fill foundations. Where adopted, granular infill should be placed beneath raft foundations on shrinkable soils as shown below.

Infill should:

- be at least 50% of the foundation depth determined for a trench fill foundation and not more than 1.25m deep (measured from ground level determined in accordance with Clause 4.2.9.2)
- extend beyond the edge of the foundation by a distance equal to its natural angle of repose, plus 0.5m
- be placed in accordance with specification within Chapter 4.6 Engineered fill.

4.2.9.4 Steps in foundations

On sloping ground, foundation trenches can be gradually stepped so that the required foundation depth is reasonably uniform below ground level.

Where foundations are to be stepped to take account of the influence of trees, hedgerows and shrubs, they should be stepped gradually, with no step exceeding 0.5m.

Figure 8: Requirements for raft foundations on shrinkable soils

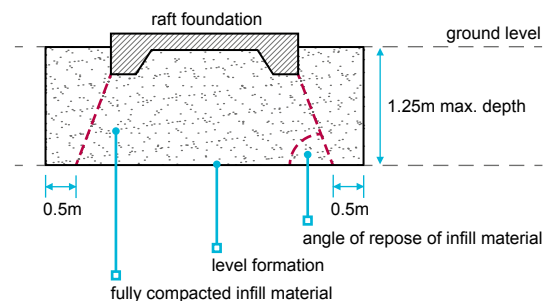

4.2.10 Heave precautions

Also see: BRE Digests 240 and 241; Chapter 2.1 and BS 5837

Foundations, substructures and services shall be suitably designed and detailed to prevent excessive movement due to heave. Heave precautions shall be incorporated into foundations and substructures in accordance with the design. Issues to be taken into account include:

- 1) potential for ground movement
- 2) minimum void dimensions
- 3) proprietary heave materials
- 4) heave precautions for foundations
- 5) other foundation types
- 6) suspended ground floors
- 7) paths and driveways.

Where foundations and substructure may be subject to heave, they should be protected by voids, void formers or compressible materials.

Where proprietary materials are used, the design of foundations and substructure should take into account the upward force transmitted through the compressible material or void former prior to collapse (refer to manufacturer's data).

This section provides guidance on heave precautions for common building elements when located within the influence of trees which are to remain or be removed, including:

- trench fill foundations
- pier and beam foundations
- pile and beam foundations
- other foundation types
- paths and driveways
- new drainage.

4.2.10.1 Potential for ground movement

After the felling or removal of trees and hedgerows on shrinkable soils, heave can occur, as the absorbed moisture causes swelling. Heave can also occur beneath a building where:

- roots are severed
- water enters the ground from leaking drains and services
- there are changes in groundwater conditions.

4.2.10.2 Minimum void dimensions

VOIDS SHOULD BE PROVIDED TO ACCOMMODATE MOVEMENT DUE TO HEAVE FORCES ACTING AGAINST FOUNDATIONS AND SUSPENDED GROUND FLOORS IN ACCORDANCE WITH TABLE 7.

Table 7: Void dimensions

Volume change potential	Void dimension against side of foundation and ground beam	Void dimension under ground beams, and suspended in-situ concrete ground floor	Void dimension under suspended precast concrete and timber floors ⁽¹⁾
High	35mm	150mm	300mm
Medium	25mm	100mm	250mm
Low	0mm	50mm	200mm

Note

1. Under suspended floors, the void dimension is measured from the underside of beam or joist to ground level and includes 150mm ventilation allowance.

Void formers consist of materials that collapse to form a void into which the clay can swell. The void dimension is the remaining void after collapse. The thickness of the void former should be in accordance with the manufacturer’s recommendations.

4.2.10.3 Proprietary materials to accommodate heave

Compressible material compacts as clay expands; the void dimension is the amount the material should be able to compress to accommodate heave. The thickness of compressible material required should be established from the manufacturer’s recommendations, but generally will be approximately twice the void dimension shown.

Each material should be assessed in accordance with Technical Requirement R3 and used in accordance with the independent assessment and the manufacturer’s recommendations.

The correct placement of heave materials is essential to ensure the foundations and substructure are adequately protected from heave forces.

4.2.10.4 Heave precautions for foundations

Table 8 shows where heave precautions are required for trench fill, pier and beam, and pile and beam foundation types which are in the zone of influence of trees (see Table 3b) which are to remain or be removed.

Table 8: Position of heave precautions

Situation (see Figures 9, 10 and 11)	Trench fill	Pier and beam	Pile and beam
External trench fill and pier foundations. Unless NHBC is satisfied that the soil is not desiccated, compressible material should be provided to the:	Inside faces of external wall foundations deeper than 1.5m, based on the appropriate tree height	All faces of pier foundations deeper than 1.5m, based on the appropriate tree height	N/A
External ground beams Unless NHBC is satisfied that the soil is not desiccated, compressible material or void formers should be provided to the:	N/A	Inside faces	Inside faces
Internal trench fill foundations and ground beams Compressible material required:	No	No	No
External and internal ground beams Compressible material, void former or void should be provided to the underside of:	N/A	All	All
Heave precautions required for proposed trees where the soil is not desiccated:	No	No	No

On pilecaps, heave precaution measures should be assessed on a project-by-project basis. Lightly loaded pilecaps consisting of between one and three piles are more susceptible to heave movement than heavily loaded pilecaps. Omission of heave precaution measures should be justified by the designers, particularly on lightly loaded pilecaps.

Figure 9: Heave precautions for trench fill foundations up to 2.5m deep

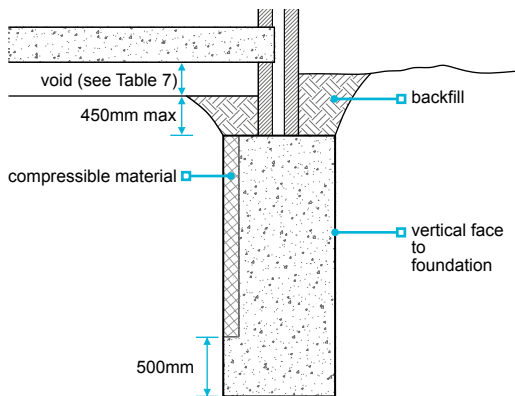

It is essential that:

- compressible material is provided to the entire area shown, and the foundation excavation has a vertical face
- where the excavation is battered or if there is overbreak or concrete overspill, it may be necessary to consult an engineer.

Figure 10: Heave precautions for pier and beam foundations

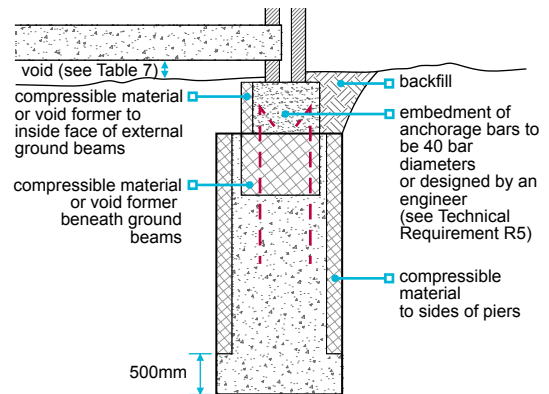

It is essential that heave material is provided to the entire areas shown. Particular care should be taken to ensure that the full width of the ground beam is protected.

Figure 11: Heave precautions for pile and beam foundations

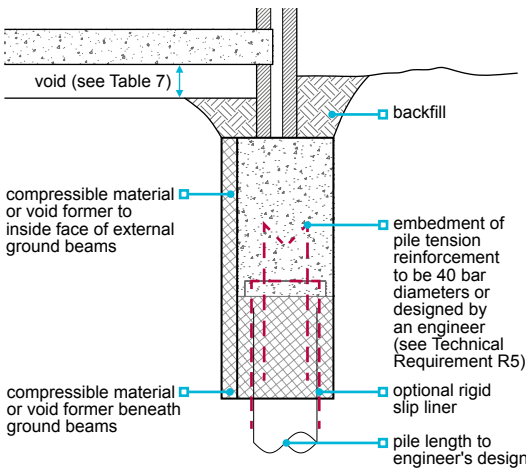

It is essential that heave material is provided to the entire areas shown. Particular care should be taken to ensure that the full width of the ground beam and the areas around the piles are protected.

Raft foundations constructed in accordance with Clause 4.2.8 and Clause 4.2.9 should provide adequate protection from heave.

4.2.10.5 Other foundation types

All foundations not covered in this chapter, but specifically designed to counteract heave, should be:

- designed by an engineer taking account of this guidance
- submitted to NHBC prior to commencing work on site.

4.2.10.6 Suspended ground floors

Suspended ground floors with voids in accordance with Table 7 should be used in situations where heave can occur within the area bounded by the foundations, including where:

- foundation depth, determined in accordance with this chapter, is more than 1.5m, unless NHBC is satisfied the soil is not desiccated, or
- ground floor construction is undertaken when the surface soils are desiccated from seasonal events or activities like crop cultivation and extreme weather patterns, unless NHBC is satisfied the soil is not desiccated. See Clause 5.1.4.5 for example.

4.2.10.7 Paths and driveways

Paths and driveways should be designed and detailed to cater for the likely ground movement.

4.2.11 New drainage

Also see: Chapter 5.3

Drainage shall be in accordance with the design and allow for ground movement.

To protect against the effects of heave, drainage should be designed:

- to take account of potential ground movement as shown in Table 9, including where pipes and services pass through substructure walls or foundations
- with gradients which may need to be greater than those in Chapter 5.3 Drainage below ground as these do not account for possible ground movement
- to use alternative means of catering for the movement when sufficient falls cannot be provided, for example by deepening the excavation and laying the pipework on a granular bedding of suitable thickness to reduce the extent of potential movement.

Table 9: Minimum allowance for potential ground movement

Volume change potential	Potential ground movement (mm)
High	150
Medium	100
Low	50

Note

1. Existing land drains should be maintained or diverted.

Where the void beneath a suspended floor is liable to flooding, adequate drainage should be provided to take away any flood water.

4.2.12 Method of assessment of foundation depths using charts

Foundation depths shall be determined to prevent excessive movement due to ground heave.

A detailed method of assessing foundation depths of up to 2.5m using Charts 1-3 are given in the worked example of Clause 4.2.14.

Table 10 can be used in determining the D/H ratio needed for use within the charts, where:

D is the distance measured from the centre of the trees or hedgerows to the face of the foundation and

H is the appropriate height of trees (mature or actual, depending on what is being assessed).

Table 10: Determination of D/H value

Determination of D/H value															
Distance D (m)	Tree H (m)														
	2	4	6	8	10	12	14	16	18	20	22	24	26	28	30
1	0.50	0.25	0.17	0.13	0.10	0.08	0.07	0.06	0.06	0.05	0.05	0.04	0.04	0.04	0.03
2	1.00	0.50	0.33	0.25	0.20	0.17	0.14	0.13	0.11	0.10	0.09	0.08	0.08	0.07	0.07
3		0.75	0.50	0.38	0.30	0.25	0.21	0.19	0.17	0.15	0.14	0.13	0.12	0.11	0.10
4		1.00	0.67	0.50	0.40	0.33	0.29	0.25	0.22	0.20	0.18	0.17	0.15	0.14	0.13
5			0.83	0.63	0.50	0.42	0.36	0.31	0.28	0.25	0.23	0.21	0.19	0.18	0.17
6			1.00	0.75	0.60	0.50	0.43	0.38	0.33	0.30	0.27	0.25	0.23	0.21	0.20
7			1.17	0.88	0.70	0.58	0.50	0.44	0.39	0.35	0.32	0.29	0.27	0.25	0.23
8				1.00	0.80	0.67	0.57	0.50	0.44	0.40	0.36	0.33	0.31	0.29	0.27
9				1.13	0.90	0.75	0.64	0.56	0.50	0.45	0.41	0.38	0.35	0.32	0.30
10					1.00	0.83	0.71	0.63	0.56	0.50	0.45	0.42	0.38	0.36	0.33
11					1.10	0.92	0.79	0.69	0.61	0.55	0.50	0.46	0.42	0.39	0.37
12					1.20	1.00	0.86	0.75	0.67	0.60	0.55	0.50	0.46	0.43	0.40
13						1.08	0.93	0.81	0.72	0.65	0.59	0.54	0.50	0.46	0.43
14						1.17	1.00	0.88	0.78	0.70	0.64	0.58	0.54	0.50	0.47
15							1.07	0.94	0.83	0.75	0.68	0.63	0.58	0.54	0.50
16							1.14	1.00	0.89	0.80	0.73	0.67	0.62	0.57	0.53
17							1.21	1.06	0.94	0.85	0.77	0.71	0.65	0.61	0.57
18								1.13	1.00	0.90	0.82	0.75	0.69	0.64	0.60
19								1.19	1.06	0.95	0.86	0.79	0.73	0.68	0.63
20									1.11	1.00	0.91	0.83	0.77	0.71	0.67
21									1.17	1.05	0.95	0.88	0.81	0.75	0.70
22										1.10	1.00	0.92	0.85	0.79	0.73
23										1.15	1.05	0.96	0.88	0.82	0.77
24										1.20	1.09	1.00	0.92	0.86	0.80
25											1.14	1.04	0.96	0.89	0.83
26											1.18	1.08	1.00	0.93	0.87
27												1.13	1.04	0.96	0.90
28												1.17	1.08	1.00	0.93
29												1.21	1.12	1.04	0.97
30													1.15	1.07	1.00
31													1.19	1.11	1.03
32														1.14	1.07
33														1.18	1.10
34														1.21	1.13
35															1.17
36															1.20

Where no value is given in the table, minimum foundation depths apply (ie, 1.0m, 0.9m and 0.75 m for high, medium and low volume change potential soils respectively).

Chart 1: Soils with HIGH volume change potential — Modified Plasticity Index 40% or greater

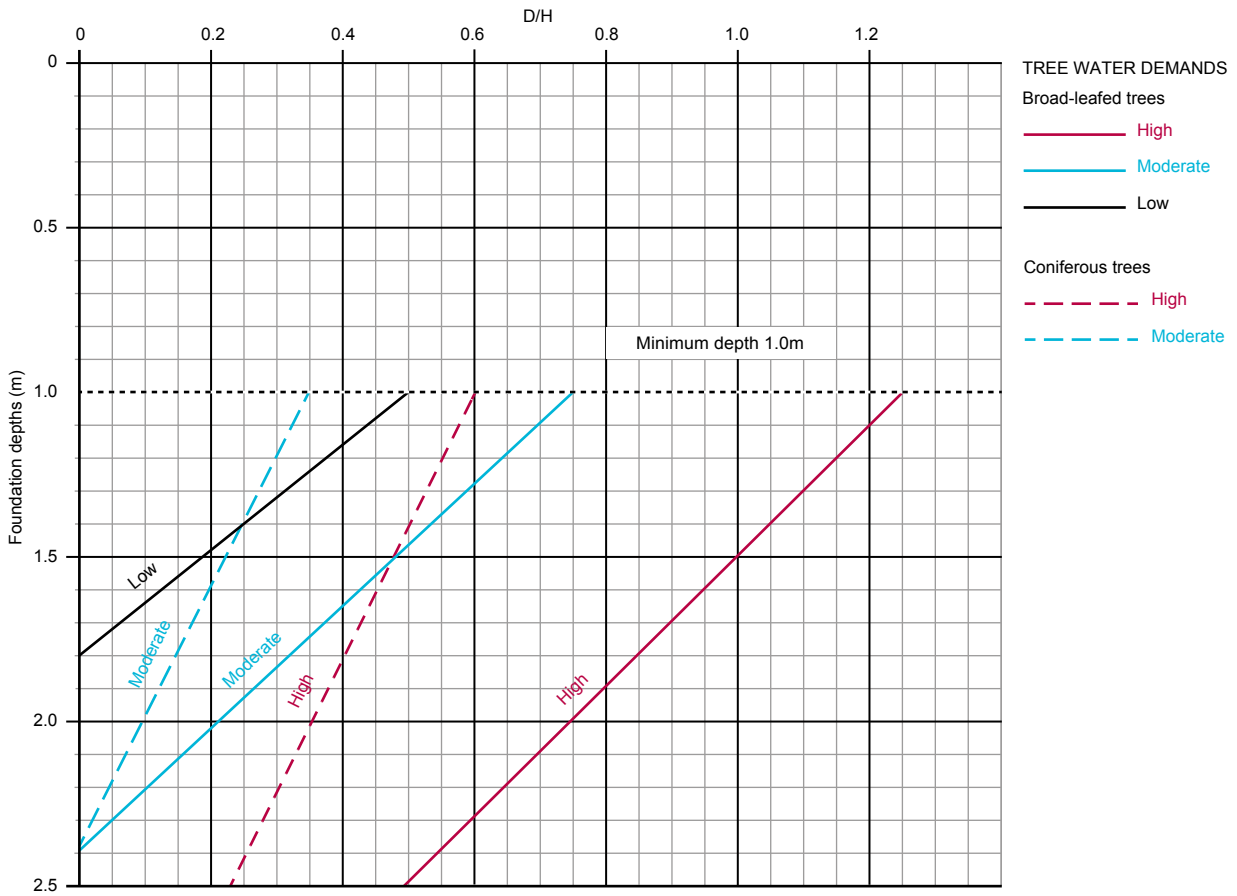

Chart 2: Soils with MEDIUM volume change potential — Modified Plasticity Index between 20% and less than 40%

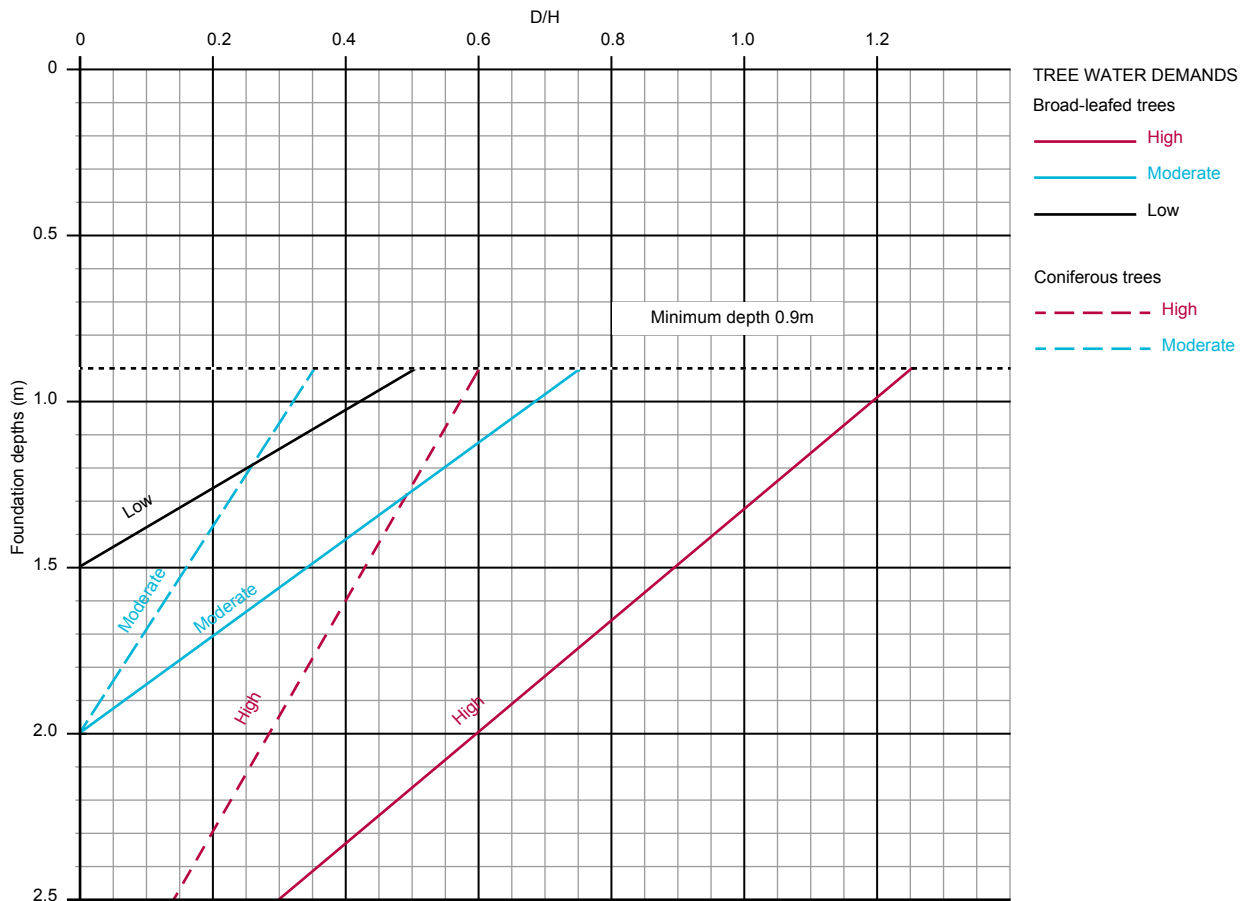
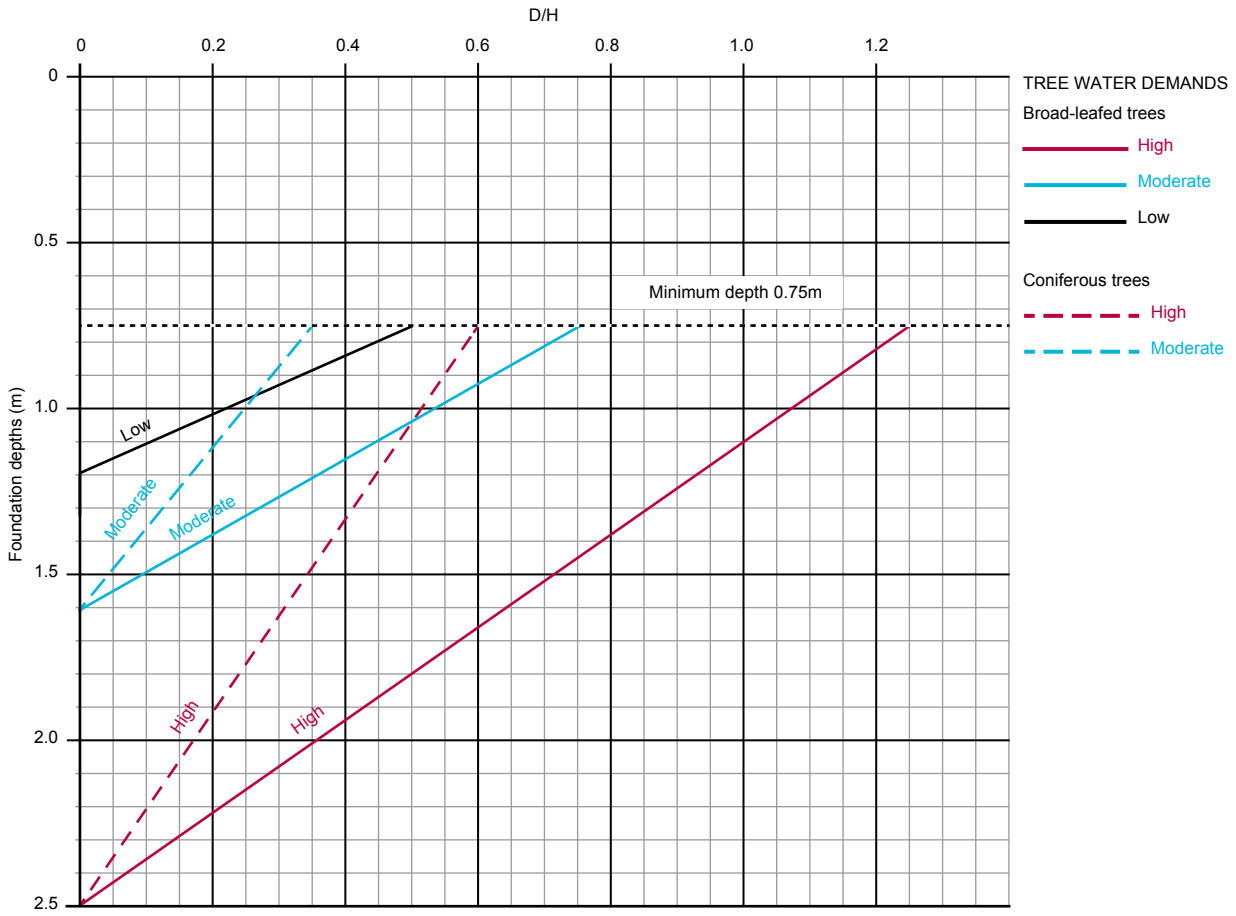

Chart 3: Soils with LOW volume change potential — Modified Plasticity Index 10 to less than 20%



4.2.13 Method of assessment of foundation depths using tables

Foundation depths shall be determined to prevent excessive movement due to ground heave.

A detailed method of assessing foundation depths of up to 2.5m using Tables 11-19 are given in the worked example of Clause 4.2.14.

Tables 11-13 are for use in High volume change potential soils, and Tables 14-16 and 17-19 are for use in Medium and Low volume change potential soils respectively.

Table 11: HIGH volume change potential soil and HIGH water demand tree

Broad-leafed trees												Coniferous trees													
Foundation depth (m)												Foundation depth (m)													
Distance D (m)	Tree height H (m)											Distance D (m)	Tree height H (m)												
	8	10	12	14	16	18	20	22	24	26	28		30	8	10	12	14	16	18	20	22	24	26	28	30
1																									
2																									
3																									
4	2.50																								
5	2.25	2.50																							
6	2.00	2.30	2.50																						
7	1.75	2.10	2.35	2.50																					
8	1.50	1.90	2.20	2.40	2.50																				
9	1.25	1.70	2.00	2.25	2.40	2.50																			
10	1.00	1.50	1.85	2.10	2.25	2.40	2.50																		
11	1.00	1.30	1.70	1.95	2.15	2.30	2.40	2.50																	
12	1.00	1.10	1.50	1.80	2.00	2.20	2.30	2.45	2.50																
13		1.00	1.35	1.65	1.90	2.10	2.20	2.35	2.45	2.50															
14		1.00	1.20	1.50	1.75	1.95	2.10	2.25	2.35	2.45	2.50														
15			1.00	1.40	1.65	1.85	2.00	2.15	2.25	2.35	2.45	2.50													
16				1.00	1.25	1.50	1.75	1.90	2.05	2.20	2.30	2.40	2.45												
17					1.00	1.10	1.40	1.65	1.80	1.95	2.10	2.20	2.30	2.40											
18						1.00	1.25	1.50	1.70	1.90	2.00	2.15	2.25	2.30											
19							1.00	1.15	1.40	1.60	1.80	1.95	2.05	2.15	2.25										
20								1.00	1.30	1.50	1.70	1.85	2.00	2.10	2.20										
21									1.00	1.20	1.40	1.60	1.75	1.90	2.00	2.10									
22										1.00	1.10	1.30	1.50	1.70	1.85	1.95	2.05								
23											1.00	1.20	1.45	1.60	1.75	1.90	2.00								
24												1.00	1.10	1.35	1.50	1.65	1.80	1.90							
25													1.00	1.25	1.45	1.60	1.75	1.85							
26														1.00	1.15	1.35	1.50	1.65	1.80						
27															1.00	1.05	1.25	1.45	1.60	1.70					
28																1.00	1.20	1.35	1.50	1.65					
29																	1.00	1.10	1.30	1.45	1.60				
30																		1.00	1.20	1.40	1.50				
31																			1.00	1.15	1.30	1.45			
32																				1.00	1.05	1.25	1.40		
33																					1.00	1.15	1.30		
34																						1.00	1.10	1.25	
35																							1.00	1.20	
36																								1.00	1.10
37																									1.00
38																									1.00

Table 14: MEDIUM volume change potential soil and HIGH water demand tree

Broad-leafed trees													Coniferous trees																	
Foundation depth (m)													Foundation depth (m)																	
Distance D (m)	Tree height H (m)												Distance D (m)	Tree height H (m)																
	8	10	12	14	16	18	20	22	24	26	28	30		8	10	12	14	16	18	20	22	24	26	28	30					
1													1																	
2													2	2.15	2.30	2.45	2.50	Foundations greater than 2.5m deep to be engineer designed												
3	2.40	2.50											3	1.70	1.95	2.15	2.25	2.35	2.45	2.50										
4	2.20	2.35	2.45										4	1.25	1.60	1.85	2.00	2.15	2.25	2.30	2.40	2.45	2.50	2.50						
5	1.95	2.20	2.30	2.40	2.50								5	0.90	1.25	1.55	1.75	1.95	2.05	2.15	2.20	2.30	2.35	2.40	2.45	2.45				
6	1.75	2.00	2.20	2.30	2.40	2.45	2.50						6		0.90	1.25	1.50	1.70	1.85	1.95	2.05	2.15	2.20	2.25	2.30	2.30				
7	1.55	1.85	2.05	2.20	2.30	2.35	2.45	2.50					7			1.00	1.25	1.50	1.65	1.80	1.90	2.00	2.10	2.15	2.20	2.20				
8	1.35	1.70	1.90	2.05	2.20	2.25	2.35	2.40	2.45	2.50			8			0.90	1.00	1.25	1.45	1.60	1.75	1.85	1.95	2.00	2.10					
9	1.15	1.50	1.75	1.95	2.10	2.20	2.25	2.35	2.40	2.45	2.50	2.50	9				0.90	1.05	1.25	1.45	1.60	1.70	1.80	1.90	1.95					
10	0.90	1.35	1.60	1.80	1.95	2.10	2.20	2.25	2.30	2.35	2.40	2.45	10					0.90	1.10	1.25	1.45	1.55	1.65	1.75	1.85					
11	0.90	1.15	1.50	1.70	1.85	2.00	2.10	2.20	2.25	2.30	2.35	2.40	11						0.90	1.10	1.25	1.40	1.55	1.65	1.75					
12	0.90	1.00	1.35	1.60	1.75	1.90	2.00	2.10	2.20	2.25	2.30	2.35	12							0.90	1.10	1.25	1.40	1.50	1.60					
13		0.90	1.20	1.45	1.65	1.80	1.95	2.05	2.10	2.20	2.25	2.30	13							0.90	0.95	1.10	1.25	1.40	1.50					
14		0.90	1.05	1.35	1.55	1.70	1.85	1.95	2.05	2.10	2.20	2.25	14							0.90	1.00	1.15	1.25	1.40	1.50					
15			0.90	1.20	1.45	1.60	1.75	1.85	1.95	2.05	2.10	2.20	15								0.90	1.00	1.15	1.25	1.40					
16			0.90	1.10	1.35	1.55	1.70	1.80	1.90	2.00	2.05	2.10	16									0.90	1.00	1.15	1.25					
17			0.90	1.00	1.25	1.45	1.60	1.70	1.85	1.90	2.00	2.05	17										0.90	1.00	1.15					
18				0.90	1.15	1.35	1.50	1.65	1.75	1.85	1.95	2.00	18											0.90	1.05					
19				0.90	1.05	1.25	1.40	1.55	1.70	1.80	1.90	1.95	19												0.90					
20					0.90	1.15	1.35	1.50	1.60	1.75	1.80	1.90	20																	
21					0.90	1.05	1.25	1.40	1.55	1.65	1.75	1.85	21																	
22					0.90	0.95	1.15	1.35	1.50	1.60	1.70	1.80	22																	
23						0.90	1.10	1.25	1.40	1.55	1.65	1.75	23																	
24						0.90	1.00	1.20	1.35	1.45	1.60	1.70	24																	
25							0.90	1.10	1.25	1.40	1.50	1.60	25																	
26							0.90	1.05	1.20	1.35	1.45	1.55	26																	
27							0.90	0.95	1.15	1.30	1.40	1.50	27																	
28								0.90	1.05	1.20	1.35	1.45	28																	
29								0.90	1.00	1.15	1.30	1.40	29																	
30									0.90	1.10	1.20	1.35	30																	
31									0.90	1.00	1.15	1.30	31																	
32									0.90	0.95	1.10	1.25	32																	
33										0.90	1.05	1.15	33																	
34										0.90	1.00	1.10	34																	
35											0.90	1.05	35																	
36												0.90	1.00	36																
37												0.90	0.95	37																
38													0.90	38																

Table 17: LOW volume change potential soil and HIGH water demand tree

Broad-leafed trees													Coniferous												
Foundation depth (m)													Foundation depth (m)												
Distance D (m)	Tree height H (m)												Distance D (m)	Tree height H (m)											
	8	10	12	14	16	18	20	22	24	26	28	30		8	10	12	14	16	18	20	22	24	26	28	30
1	2.35	2.40	2.40	2.40	2.45	2.45	2.45	2.45	2.45	2.45	2.45	2.45	1	2.15	2.25	2.30	2.30	2.35	2.35	2.35	2.40	2.40	2.40	2.40	
2	2.15	2.25	2.30	2.30	2.35	2.35	2.40	2.40	2.40	2.40	2.40	2.45	2	1.80	1.95	2.05	2.10	2.15	2.20	2.25	2.25	2.30	2.30	2.35	
3	2.00	2.10	2.15	2.20	2.25	2.30	2.30	2.35	2.35	2.35	2.35	2.40	3	1.45	1.65	1.80	1.90	1.95	2.05	2.10	2.10	2.15	2.20	2.25	
4	1.80	1.95	2.05	2.10	2.15	2.20	2.25	2.25	2.30	2.30	2.30	2.35	4	1.05	1.35	1.55	1.70	1.80	1.85	1.95	2.00	2.05	2.10	2.15	
5	1.65	1.80	1.95	2.00	2.10	2.15	2.15	2.20	2.25	2.25	2.25	2.30	5	0.75	1.05	1.30	1.50	1.60	1.70	1.80	1.85	1.90	1.95	2.00	
6	1.45	1.70	1.80	1.90	2.00	2.05	2.10	2.15	2.15	2.20	2.20	2.25	6	0.75	1.05	1.25	1.45	1.55	1.65	1.70	1.80	1.85	1.90	1.95	
7	1.30	1.55	1.70	1.80	1.90	2.00	2.05	2.05	2.10	2.15	2.15	2.20	7	0.75	0.80	1.05	1.25	1.40	1.50	1.60	1.65	1.75	1.80	1.85	
8	1.10	1.40	1.60	1.70	1.80	1.90	1.95	2.00	2.05	2.10	2.10	2.15	8	0.75	0.85	1.05	1.20	1.35	1.45	1.55	1.60	1.70	1.75		
9	0.95	1.25	1.45	1.60	1.75	1.80	1.90	1.95	2.00	2.05	2.05	2.10	9	0.75	0.90	1.05	1.20	1.35	1.45	1.50	1.60	1.65			
10	0.75	1.10	1.35	1.50	1.65	1.75	1.80	1.90	1.95	2.00	2.00	2.05	10	0.75	0.90	1.05	1.20	1.30	1.40	1.50	1.55				
11	0.75	1.00	1.20	1.40	1.55	1.65	1.75	1.80	1.90	1.95	1.95	2.00	11	0.75	0.90	1.05	1.20	1.30	1.35	1.45					
12	0.75	0.85	1.10	1.30	1.45	1.60	1.70	1.75	1.80	1.85	1.90	1.95	12	0.75	0.95	1.05	1.15	1.25	1.35						
13	0.75	1.00	1.20	1.40	1.50	1.60	1.70	1.75	1.80	1.85	1.90	13	0.75	0.80	0.95	1.05	1.15	1.25							
14	0.75	0.90	1.10	1.30	1.45	1.55	1.65	1.70	1.75	1.80	1.85	14	0.75	0.80	0.95	1.05	1.15								
15	0.75	1.00	1.20	1.35	1.45	1.55	1.65	1.70	1.75	1.80	15	0.75	0.85	0.95	1.05										
16	0.75	0.90	1.10	1.30	1.40	1.50	1.60	1.65	1.70	1.75	16	0.75	0.85	0.95											
17	0.75	0.80	1.05	1.20	1.35	1.45	1.55	1.60	1.65	1.75	17	0.75	0.85												
18	0.75	0.95	1.10	1.25	1.35	1.45	1.55	1.60	1.70	18	0.75														
19	0.75	0.85	1.05	1.20	1.30	1.40	1.50	1.55	1.65	19															
20	0.75	0.95	1.10	1.25	1.35	1.45	1.50	1.60	20																
21	0.75	0.90	1.05	1.20	1.30	1.40	1.45	1.55	21																
22	0.75	0.80	1.00	1.10	1.25	1.35	1.40	1.50	22																
23	0.75	0.90	1.05	1.20	1.30	1.35	1.45	23																	
24	0.75	0.85	1.00	1.10	1.25	1.30	1.40	24																	
25	0.75	0.95	1.05	1.15	1.25	1.35	25																		
26	0.75	0.85	1.00	1.10	1.20	1.30	26																		
27	0.75	0.80	0.95	1.05	1.15	1.25	27																		
28	0.75	0.90	1.00	1.10	1.20	28																			
29	0.75	0.85	0.95	1.05	1.15	29																			
30	0.75	0.90	1.00	1.10	30																				
31	0.75	0.85	0.95	1.05	31																				
32	0.75	0.80	0.90	1.05	32																				
33	0.75	0.85	1.00	33																					
34	0.75	0.80	0.95	34																					
35	0.75	0.90	35																						
36	0.75	0.85	36																						
37	0.75	0.80	37																						
38	0.75	38																							

Table 18: LOW volume change potential soil and MODERATE water demand tree

Broad-leafed trees													Coniferous												
Foundation depth (m)													Foundation depth (m)												
Distance D (m)	Tree height H (m)												Distance D (m)	Tree height H (m)											
	8	10	12	14	16	18	20	22	24	26	28	30		8	10	12	14	16	18	20	22	24	26	28	30
1	1.50	1.50	1.55	1.55	1.55	1.55	1.55	1.55	1.55	1.60	1.60	1.60	1	1.30	1.40	1.40	1.45	1.45	1.50	1.50	1.50	1.55	1.55	1.55	
2	1.35	1.40	1.45	1.45	1.50	1.50	1.50	1.50	1.55	1.55	1.55	1.55	2	1.00	1.15	1.20	1.25	1.30	1.35	1.40	1.40	1.45	1.45	1.45	
3	1.20	1.30	1.35	1.40	1.40	1.45	1.45	1.45	1.50	1.50	1.50	1.50	3	0.75	0.90	1.00	1.10	1.15	1.20	1.25	1.30	1.30	1.35	1.35	1.40
4	1.05	1.15	1.25	1.30	1.35	1.35	1.40	1.40	1.45	1.45	1.45	1.45	4		0.75	0.80	0.95	1.00	1.10	1.15	1.20	1.20	1.25	1.25	1.30
5	0.90	1.05	1.15	1.20	1.25	1.30	1.35	1.35	1.40	1.40	1.40	1.40	5			0.75	0.75	0.85	0.95	1.00	1.05	1.10	1.10	1.15	1.20
6	0.75	0.95	1.05	1.15	1.20	1.25	1.30	1.30	1.35	1.35	1.40	1.40	6				0.75	0.80	0.90	0.95	1.00	1.05	1.10	1.15	
7	0.75	0.85	0.95	1.05	1.10	1.20	1.20	1.25	1.30	1.30	1.35	1.35	7				0.75	0.75	0.85	0.90	0.95	1.00	1.05	1.10	
8		0.75	0.85	0.95	1.05	1.10	1.15	1.20	1.25	1.25	1.30	1.30	8					0.75	0.80	0.85	0.95	1.00	1.05	1.10	
9			0.75	0.90	1.00	1.05	1.10	1.15	1.20	1.25	1.25	1.30	9						0.75	0.80	0.85	0.95	1.00	1.05	
10			0.75	0.80	0.90	1.00	1.05	1.10	1.15	1.20	1.20	1.25	10							0.75	0.75	0.85	0.90	0.95	
11				0.75	0.85	0.95	1.00	1.05	1.10	1.15	1.15	1.20	11								0.75	0.75	0.80	0.80	
12					0.75	0.85	0.95	1.00	1.05	1.10	1.15	1.15	12											0.75	
13					0.75	0.80	0.90	0.95	1.00	1.05	1.10	1.15	13												
14						0.75	0.85	0.90	0.95	1.00	1.05	1.10	14												
15							0.75	0.85	0.90	0.95	1.00	1.05	15												
16							0.75	0.80	0.85	0.90	0.95	1.00	16												
17								0.75	0.80	0.90	0.95	1.00	17												
18									0.75	0.85	0.90	0.95	18												
19									0.75	0.80	0.85	0.90	19												
20										0.75	0.80	0.85	20												
21											0.75	0.85	21												
22												0.75	0.80	22											
23												0.75		23											

Table 19: LOW volume change potential soil and LOW water demand tree

Broad-leafed trees												
Foundation depth (m)												
Distance D (m)	Tree height H (m)											
	8	10	12	14	16	18	20	22	24	26	28	30
1	1.10	1.15	1.15	1.15	1.15	1.15	1.20	1.20	1.20	1.20	1.20	1.20
2	1.00	1.05	1.05	1.10	1.10	1.10	1.15	1.15	1.15	1.15	1.15	1.15
3	0.90	0.95	1.00	1.05	1.05	1.05	1.10	1.10	1.10	1.10	1.10	1.15
4	0.75	0.85	0.90	0.95	1.00	1.00	1.05	1.05	1.05	1.10	1.10	1.10
5		0.75	0.85	0.90	0.95	0.95	1.00	1.00	1.05	1.05	1.05	1.05
6			0.75	0.85	0.90	0.90	0.95	0.95	1.00	1.00	1.05	1.05
7				0.75	0.85	0.85	0.90	0.95	0.95	1.00	1.00	1.00
8					0.75	0.80	0.85	0.90	0.90	0.95	0.95	1.00
9						0.75	0.80	0.85	0.90	0.90	0.95	0.95
10							0.75	0.80	0.85	0.85	0.90	0.90
11								0.75	0.80	0.85	0.85	0.90
12									0.75	0.80	0.85	0.85
13										0.75	0.80	0.85
14											0.75	0.80
15												0.75

4.2

4.2.14 Worked example

The following is an example of how to determine foundation depths using the information in this chapter. The process may be repeated to allow the foundation to be stepped as its distance from the tree increases.

Step 1

Determine the volume change potential of the soil. Ensure the site investigation includes representative sampling and testing.

Site at Oxford, building near a Lombardy poplar (to be retained) and a sycamore (to be removed).

From laboratory tests:

Plasticity Index, $I_p = 36\%$

Test results also report that 100% of particles are smaller than $425\mu\text{m}$.

Therefore:

$$\text{Modified Plasticity Index, } I'_p = \frac{36 \times 100}{100} = 36\%$$

Volume change potential = medium

(In the absence of tests, assume high volume change potential).

This example is typical of Oxford clay. More than 35% of the particles are smaller than $60\mu\text{m}$; therefore, the soil is shrinkable. 100% of the particles are smaller than $425\mu\text{m}$; therefore, I'_p is the same as the I_p .

A typical boulder clay also has more than 35% of particles smaller than $60\mu\text{m}$ and is therefore also shrinkable. However, it may have only 80% of its particles smaller than $425\mu\text{m}$, in which case, the I'_p is 80% of the I_p .

A typical clayey sand may have less than 30% of its particles smaller than $60\mu\text{m}$, in which case, the soil would be non-shrinkable.

Step 2

Establish the species, mature height and water demand of all trees and hedgerows within the influencing radii.

Lombardy poplar	Sycamore
Mature height = 25m Water demand = high	Mature height = 22m Water demand = moderate

Step 3

Plot the trees and hedgerows relative to the foundations and draw their zones of influence to determine which trees will affect the foundation design. Use a scaled plan.

Figure 12: Layout depicting zones of influence of trees

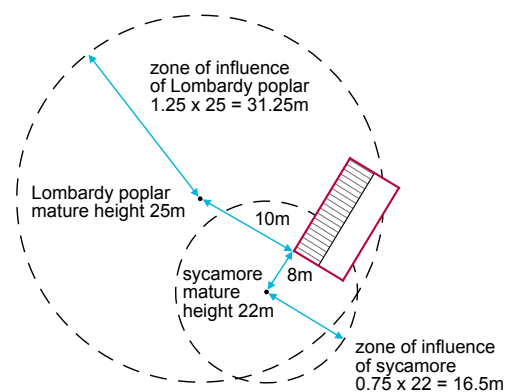

Step 4

Establish the appropriate tree height H to use.

Always use the mature height for remaining and proposed trees and hedgerows. The appropriate height to use for removed trees and hedgerows depends on the actual height when they are removed.

Lombardy poplar	Sycamore
Tree to remain. Therefore: H = mature height = 25m	Tree to be removed Mature height = 22m Actual height = 15m Actual height greater than 50% mature height. Therefore: H = mature height = 22m

Step 5

Measure the distance D from the centre of the trees or hedgerows to the face of the foundation.

Lombardy poplar	Sycamore
Distance D = 10m from foundation	Distance D = 8m from foundation

Step 6

Either:

- use the NHBC Foundation Depth Calculator App, or
- select steps 6C (a) and (b) if using charts in Clause 4.2.12 to derive depths, or
- select step 6T if using tables in Clause 4.2.13.

Step 6C (a)

Calculate D/H value.

Distance D from face of foundation (Step 5) divided by the appropriate tree height H (Step 4).
Alternatively, D/H can be obtained from Clause 4.2.12.

Lombardy poplar	Sycamore
$D = 10 = D/H = 0.4$ $H = 25$	$D = 8 = D/H = 0.36$ $H = 22$

Step 6C (b)

Determine foundation depth using the charts in Clause 4.2.12 as follows:

Volume change potential	Chart number
High	1
Medium	2
Low	3

Lombardy poplar	Sycamore
In this example, the volume change potential is medium, then from Chart 2 for broad-leaved high water demand trees at $D = 0.4$ H Foundation depth = 2.33m	In this example, the volume change potential is medium, then from Chart 2 for broad-leaved moderate water demand trees at $D = 0.36$ H Foundation depth = 1.50m

The Lombardy poplar is the tree requiring the greater depth (2.33m).

Step 6T

Determine foundation depth using the tables in Clause 4.2.13 as follows:

Volume change potential	Tree water demand	Table number
High	High	11
	Moderate	12
	Low	13
Medium	High	14
	Moderate	15
	Low	16
Low	High	17
	Moderate	18
	Low	19

Step 7

Adjust the depth according to the climatic zone.

A reduction may be made for distance north and west of London, but the final depth should not be less than the minimum given in each chart and table.

Oxford is between 50 and 100 miles northwest of London. From Figure 2 of Clause 4.2.4, a reduction of 0.05m is permitted.

Final foundation depth = 2.33 – 0.05 = 2.28m

4.2.15 Further information

- *BRE Digests 240, 241 and 242 Low rise buildings on shrinkable clay soils, parts 1, 2 and 3*
- *BRE Digest 298 The influence of trees on house foundations in clay soils*
- *BRE Digest 412 Desiccation in clay soils*
- *BS 1377 Methods of test for soils for civil engineering purposes*
- *BS 5837 Trees in relation to design, demolition and construction — Recommendations*
- *BS 5930 Code of practice for ground investigations*
- *Tree Recognition — A Pocket Manual by Ian Richardson and Rowena Gale, Richardson's Botanical Identifications, 49/51 Whiteknights Road, Reading, Berks RG6 7BB*
- *Field Guide to the Trees of Britain and Northern Europe by Alan Mitchell, Harper Collins*
- *Glasgow geological survey maps obtainable from British Geological Survey, Nicker Hill, Keyworth, Nottingham NG12 5GG; Tel: 0115 936 3100*
- *Tree root damage to buildings Vol.1 Causes, Diagnosis and Remedy, Vol. 2 Patterns of Soil Drying in Proximity to Trees on Clay Soils by P G Biddle, Willowmead Publishing, Wantage OX12 9JA*
- *Institution of Civil Engineers
1-7 Great George Street, London SW1P 3AA;
Tel: 020 7222 7722; www.ice.org.uk*
- *Institution of Structural Engineers
47-58 Bastwick Street, London EC1V 3PS;
Tel: 020 7235 4535*

Acknowledgements: NHBC gratefully acknowledges the help given by authoritative organisations and individuals in the preparation of this chapter, particularly: Building Research Establishment; Dr P G Biddle, arboricultural consultant.



Chapter 4.3



Strip and trench fill foundations

This chapter gives guidance on meeting the Technical Requirements for strip and trench fill foundations.

4.3.1	Compliance	02
4.3.2	Provision of information	02
4.3.3	Ground conditions	02
4.3.4	Hazardous ground	03
4.3.5	Setting out	03
4.3.6	Services and drainage	04
4.3.7	Safe transmission of loads	05
4.3.8	Sloping ground and stepped foundations	06
4.3.9	Excavations	06
4.3.10	Reinforcement	07
4.3.11	Concrete	07
4.3.12	Movement joints	07
4.3.13	Construction joints	08
4.3.14	Further information	08

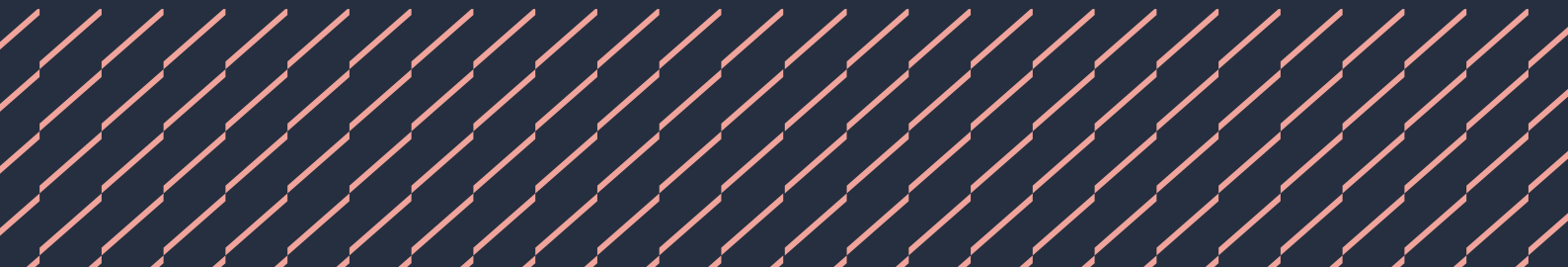

Figure reference table

Figure Reference Table 4.3

Fig No	Title/Description	Clause	Page
Figure 1	Minimum foundation depth below ground to give protection against frost damage	4.3.3.3	3
Figure 2	Minimum foundation setting out requirements	4.3.5	3
Figure 3	Diversion of land drains when interrupted by proposed development	4.3.6.1	4
Figure 4	Over-sized pipe cast as sleeve within foundations	4.3.6.2	4
Figure 5	Opening left in masonry above or near the top of foundation with lintel over	4.3.6.2	4
Figure 6	Opening left within deep trench fill foundation for service penetration	4.3.6.2	4
Figure 7	Typical foundation detail	4.3.7.2	6
Figure 8	Typical stepped foundation detail	4.3.8	6
Figure 9	Foundations with horizontal bottom and vertical sides and steps	4.3.9.3	7
Figure 10	Reinforced foundation showing reinforcement cover	4.3.10	7
Figure 11	Use of pegs to ensure correct foundation levels	4.3.11	7
Figure 12	Construction joint connected with reinforcing bars	4.3.13	8
Figure 13	Construction joint formed using expanded metal lath	4.3.13	8

4.3.1 Compliance

Also see: Chapter 2.1

Strip and trench fill foundations shall comply with the Technical Requirements and provide adequate support to all load-bearing elements.

Strip and trench fill foundations that comply with the guidance in this chapter will generally be acceptable.

Foundations should be designed by an engineer in accordance with Technical Requirement R5 where:

- buildings exceed three storeys in height
- supporting/retaining walls form habitable rooms below ground
- trench fill foundations are deeper than 2.5m
- they will be deeper than those of an adjoining construction.

Elements of the building requiring foundations include:

- external walls
- separating (party) walls
- internal load-bearing walls
- chimney breasts
- piers.

In Scotland, a sleeper wall is defined as a load-bearing element and therefore should be provided with a suitable foundation.

In England, Wales, Northern Ireland and the Isle of Man, sleeper walls should be provided with suitable foundations where the oversite concrete is:

- cast on shrinkable clay soils where heave could take place
- cast on infill deeper than 600mm
- less than 100mm thick.

4.3.2 Provision of information

Also see: Chapter 4.1

Designs and specifications shall be produced in a clearly understandable format, include all relevant information and be distributed to all appropriate personnel.

Clear and fully detailed drawings should be available on site to enable work to be carried out in accordance with the design. Design and specification information should be issued to site supervisors, relevant specialist subcontractors and/or suppliers. All necessary dimensions and levels should be indicated and relate to at least one benchmark and reference points on the site.

Information on ground conditions, the site investigation and the foundation design may be requested by NHBC, including sites which may not be classified as hazardous.

Both designers and site operatives need to be aware of the ground conditions and any features requiring special attention, such as existing sewers or other services, the water table and the presence of any hazardous substances, including sulfates.

Where toxic materials or those likely to present a health hazard are found, all available information should be supplied to NHBC, together with proposals for remediation.

Full details of junctions, steps, movement joints and any critical sequences of construction should be provided.

4.3.3 Ground conditions

Also see: Chapters 3.2, 4.1, 4.2 and 5.2

Strip and trench fill foundations shall be adequate, of a suitable depth and taken to a suitable bearing stratum. Issues to be taken into account include:

- 1) the home design and layout
- 2) ground conditions
- 3) frost susceptible soils and cold weather construction
- 4) shrinkable and volume change soils.

4.3.3.1 The home design and layout

Foundation design should take account of site conditions, shape, size and construction of the homes. Foundations for terraced homes may require special precautions to prevent damage from differential settlement, while stepped foundations or suspended floors may be required for sloping sites.

The depth of foundations should provide a clean, firm and adequate bearing for the design loads.

4.3.3.2 Ground conditions

All relevant information about the history of the site, plus the nature and load-bearing capacity of the ground, should be available before the foundations are designed. Information may be available from:

- NHBC
- local authorities
- gas, water and electricity companies
- aerial photographs, Ordnance Survey maps, and geological maps and surveys.

Site assessment surveys may require supplementary investigations involving trial pits and boreholes.

4.3.3.3 Frost susceptible soils and cold weather construction

In frost susceptible soils, eg chalk, the depth to the underside of the foundation should be at least 450mm below finished ground level, to avoid damage from frost action.

Additionally, when construction is undertaken during cold weather, the foundation should either be at least 450mm below finished ground level, or alternatively, precautions should be taken to prevent freezing of the ground.

Where the finished ground level is to be above the existing ground level and cold conditions are expected, the foundation depth should be taken from the existing, not finished, ground level.

Figure 1: Minimum foundation depth below ground to give protection against frost damage

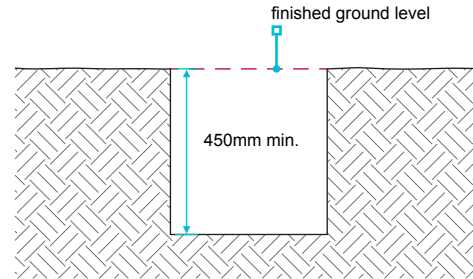

4.3.3.4 Shrinkable and volume change soil

The design should specify the minimum foundation depth.

Table 1: Minimum foundation depths in shrinkable soil

Modified Plasticity Index	Volume change potential	Minimum depth (m)
40% and greater	High	1.0
20% to less than 40%	Medium	0.9
10% to less than 20%	Low	0.75

Shrinkable soils are classified as containing more than 35% fine particles (clay and silt) and have a Modified Plasticity Index of 10% or greater.

These minimum depths may only be used where any existing or proposed trees or shrubs are outside the zone of tree influence. Heave is possible in shrinkable soil where trees have been, or are being, removed.

4.3.4 Hazardous ground

Also see: Chapters 2.1 and 4.2

Strip and trench fill foundations on hazardous ground shall be designed by an engineer, and notice given to NHBC before work commences.

Where hazardous ground has been identified, NHBC must be notified eight weeks before work starts. Hazardous ground is defined in Chapter 4.1 Land quality — managing ground conditions.

4.3.5 Setting out

Strip and trench fill foundations shall be set out to take account of the design details.

The accuracy of setting out should be checked by control measurements of trenches, including their location relative to site boundaries and adjacent buildings. Levels should be checked against accepted benchmarks.

For excavations, check:

- trench lengths
- trench widths
- length of diagonals between external corners.

Walls should be located centrally on the foundation, unless specifically designed otherwise.

Any discrepancy in dimensions should be reported promptly to the designer. Resulting variations should be distributed to all appropriate persons, including NHBC.

Figure 2: Minimum foundation setting out requirements

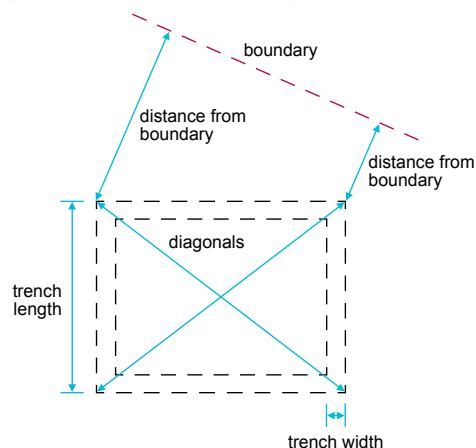

4.3.6 Services and drainage

Also see: Chapters 5.1 and 5.3

All strip and trench fill foundations shall be installed to:

- 1) adequately protect existing services and groundwater drainage
- 2) make allowance for drainage and other services.

4.3.6.1 Adequately protect existing services and groundwater drainage

Any existing services, such as cables, water pipes or gas mains, may need to be supported and protected. Services should not be rigidly encased in the foundations, and drains which are redundant should be cut open and filled or removed. Precautions should be taken to accommodate the effects of settlement where drains run under, or near to, a building.

Provision should be made to divert or protect any existing groundwater drains affected by excavation work, see Figure 3.

Figure 3: Diversion of land drains when interrupted by proposed development

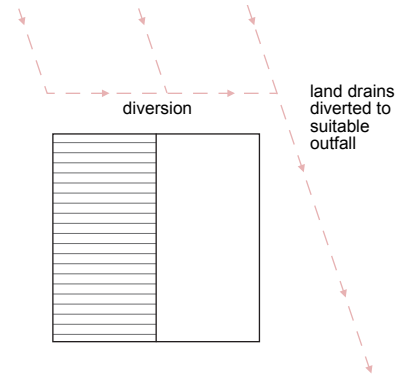

4.3.6.2 Make allowance for drainage and other services

Where services are to pass through or above foundations, provision should be made for suitable ducts or lintels to enable later installation.

Strip foundations

Services should not pass through strip foundations but through the masonry above. Adequate lintels should be provided in the masonry.

Trench fill

The load-bearing capability of foundations should not be affected where services pass through. Services should be either sleeved (Figure 4) or pass through a suitably strengthened opening in the foundation (Figures 5 and 6). This is to ensure that differential movement will not damage services.

For drainage, it is important to leave sufficient space for movement to ensure that the drain is capable of maintaining line and gradient.

Figure 4: Over-sized pipe cast as sleeve within foundations

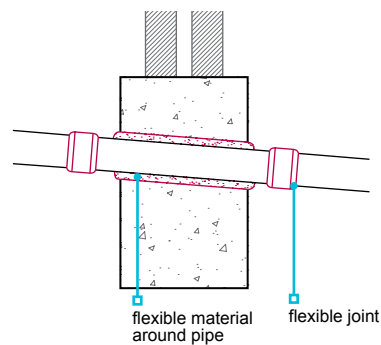

Figure 5: Opening left in masonry above or near the top of foundation with lintel over

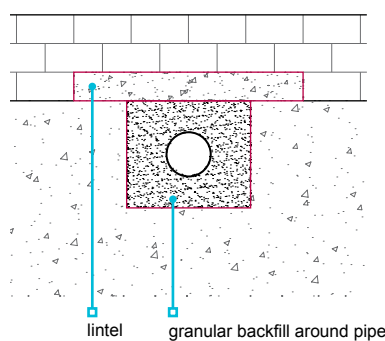
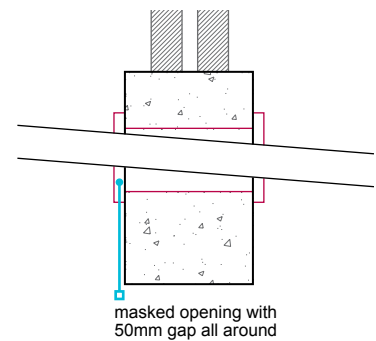

Figure 6: Opening left within deep trench fill foundation for service penetration



4.3.7 Safe transmission of loads

Also see: BS 8103-1

Strip and trench fill foundations shall transmit loads to the ground safely and without excessive settlement, and take into account:

- 1) dead and imposed loads
- 2) foundation width and thickness
- 3) stability of any adjoining building.

4.3.7.1 Dead and imposed loads

Dead and imposed loads should be calculated in accordance with:

BS EN 1991-1-1	UK National Annex to Eurocode 1: Actions on structures. General actions — Densities, self-weight, imposed loads for buildings
BS EN 1991-1-3	UK National Annex to Eurocode 1: Actions on structures. General actions — Snow loads
BS EN 1991-1-4	UK National Annex to Eurocode 1: Actions on structures. General actions — Wind actions
BS 648	Schedule of weights of building materials

All foundations should be:

- continuous throughout the building, including integral garages, porches, conservatories, bay windows, etc
- symmetrical beneath load-bearing elements (ie, walls should be located centrally on foundations).

4.3.7.2 Foundation width and thickness

The following guidance covers the design and construction of foundations only in normal or undisturbed natural ground — ie, for which the use of strip footings or trench fill foundations using unreinforced concrete, as shown in Figure 7, are sufficient. For sites where hazardous conditions exist, as described in Clause 4.3.4, and which might require reinforced strip footings, rafts or piled foundations, the design should be undertaken by a suitably qualified person.

The width of the foundation should:

- be of sufficient width throughout to avoid overstressing the ground, especially where the foundation is required to support piers or columns
- depend on the load-bearing capacity of the subsoil and the loads from the building
- not be less than the wall thickness, plus at least 50mm each side.

The width of strip foundations should account for ground conditions and be in accordance with the following table:

Table 2: Acceptable foundation widths

Type of ground	Condition of ground	Field test applicable	Total load of load-bearing walling not more than (kN/linear metre)					
			20	30	40	50	60	70
			Minimum width of strip foundation (mm)					
Rock	Not inferior to sandstone, limestone or firm chalk	Requires at least a pneumatic or other mechanically operated pick for excavation	Equal to the width of the wall plus 50mm each side					
Gravel Sand	Medium dense	Requires pick for excavation Wooden peg 50mm square in cross-section is hard to drive beyond 150mm	250	300	400	500	600	650
Clay Sandy clay	Stiff	Can be indented slightly by thumb	250	300	400	500	600	650
Clay Sandy clay	Firm	Thumb makes impression easily	300	350	450	600	750	850
Sand Silty sand Clayey sand	Loose	Can be excavated with a spade Wooden peg 50mm square in cross-section can be easily driven	400	600	Does not fall within the provisions of this guidance where the total load exceeds 30kN/linear metre			
Silt Clay Sandy clay Clay or silt	Soft	Finger can be pushed in up to 10mm	450	650				
Silt Clay Sandy clay Clay or silt	Very soft	Finger can be easily pushed in up to 25mm	Refer to specialist advice					

The thickness (T) of the foundation should be:

- equal to projection (P) or 150mm (whichever is greater)
- 150mm to 500mm for strip foundation
- 500mm minimum for trench fill foundations.

Figure 7: Typical foundation detail

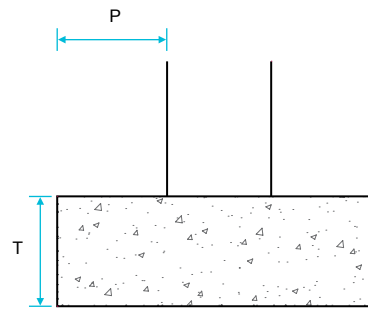

4.3.7.3 Stability of any adjoining building

Where foundations are taken deeper than an adjoining building, excavation and construction will usually need to be carefully supervised by the design engineer, to check the standard of workmanship. Where necessary, allowance should be made in the design for differential movement.

4.3.8 Sloping ground and stepped foundations

Strip and trench fill foundations shall be taken to a suitable bearing level when building on sloping ground, and steps shall be suitably formed.

Sloping ground may require stepped foundations.

Where foundations are stepped, the height of the step (S) should not exceed the thickness of the foundation (T), unless it forms part of a foundation designed by an engineer in accordance with Technical Requirement R5.

Figure 8: Typical stepped foundation detail

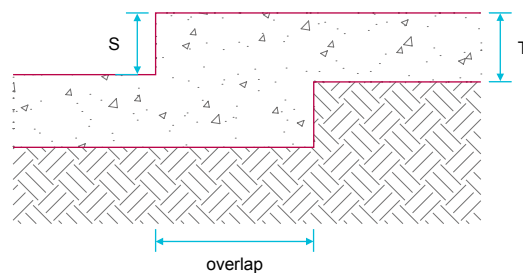

Table 3: Foundation overlap

	Strip foundations	Trench fill foundations
The overlap should be not less than:	<ul style="list-style-type: none"> • 2 x S, or • T (maximum 500mm), or • 300mm, whichever is largest 	<ul style="list-style-type: none"> • 2 x S, or • one metre, whichever is largest

4.3.9 Excavations

Also see: Chapter 4.2

Excavations for strip and trench fill foundations shall:

- 1) take account of the design dimensions
- 2) take account of localised effects
- 3) be compact, reasonably dry, even and correctly shaped.

4.3.9.1 Design dimensions

Inaccuracy may prevent walls and piers from being located centrally and therefore result in eccentric loading of foundations and possible foundation failure.

Excess excavation should be avoided. Accurate trench digging is particularly important where the width of the foundation is only slightly wider than the wall to be supported.

Acceptance from the foundation designer is required where the foundation design is modified.

4.3.9.2 Localised effects

At soft spots, excavations should be deepened to a sound bottom or the concrete should be reinforced. Hard spots should be removed.

Where roots are visible at the bottom or sides of trenches, especially in clay soils, excavations may need to be taken deeper, or special precautions determined by an engineer in accordance with Technical Requirement R5.

4.3.9.3 Compact, reasonably dry, even and correctly shaped

Unless otherwise designed by an engineer in accordance with Technical Requirement R5:

- trench bottoms should be horizontal, with all loose material removed
- trench sides and steps should be, as near as possible, vertical.

Trench bottoms affected by rainwater, groundwater or drying should be rebottomed to form a sound surface.

4.3.10 Reinforcement

Reinforcement for strip and trench fill foundations shall ensure the safe transfer of loads and be suitable for localised ground conditions.

Reinforcement should be:

- appropriately sized
- placed correctly
- clean and free from loose rust
- secured at laps and crossings
- supported to ensure that they are 75mm above the base of the foundation or as indicated in the design.

If in doubt about any soft spots, the designer's advice should be taken before placing the concrete.

4.3.11 Concrete

Concrete for foundations shall be:

- 1) of a mix which is suitable for the intended use
- 2) durable against chemical or frost action

Concreting should be carried out, as far as possible, in one operation, taking account of weather conditions and available daylight. Concrete should be placed as soon as possible after the excavation has been checked.

For trench fill foundations, it is particularly important to check that the finished level is correct and horizontal, as it is difficult to adjust for discrepancies in the small number of brick courses between the foundation and the DPC.

Concrete procurement and execution shall be in accordance with Chapter 3.1 Concrete and its reinforcement and BS EN 13670.

4.3.12 Movement joints

Strip and trench fill foundations shall have movement joints suitable for their intended purpose.

Where movement joints are specified, they should be continuous with those in the superstructure.

Figure 9: Foundations with horizontal bottom and vertical sides and steps

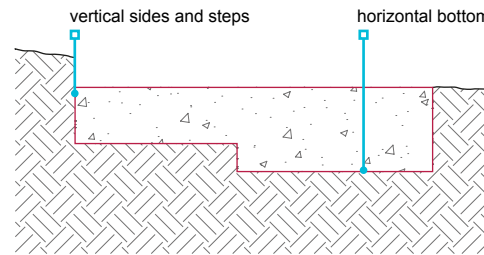

Also see: Chapter 3.1

Figure 10: Reinforced foundation showing reinforcement cover

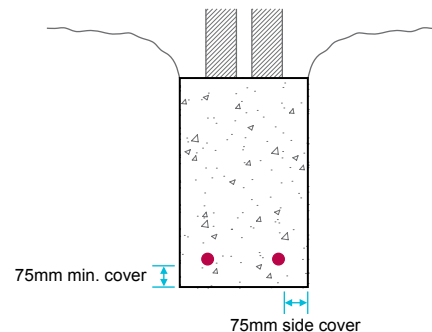

Also see: Chapters 3.1 and 3.2

- 3) correctly mixed, placed and cured.

Figure 11: Use of pegs to ensure correct foundation levels

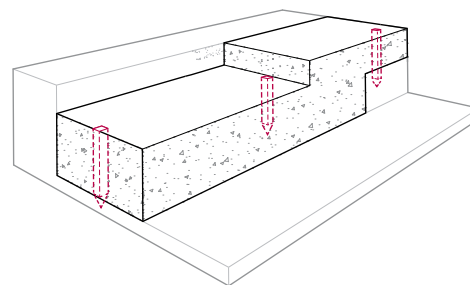

4.3.13 Construction joints

Construction joints in strip and trench fill foundations shall be suitably formed.

Where construction joints are unavoidable:

- they should not be positioned near a return in the foundation
- all shuttering should be removed before work continues beyond the construction joint

Construction joints for strip and trench fill foundations may be formed by one of the methods shown below:

Figure 12: Construction joint connected with reinforcing bars

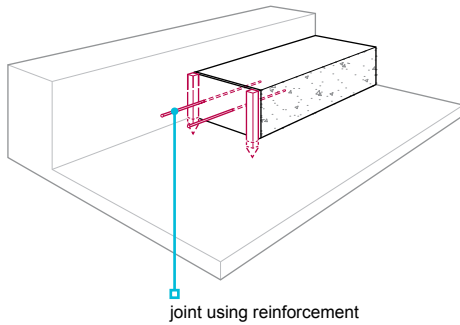
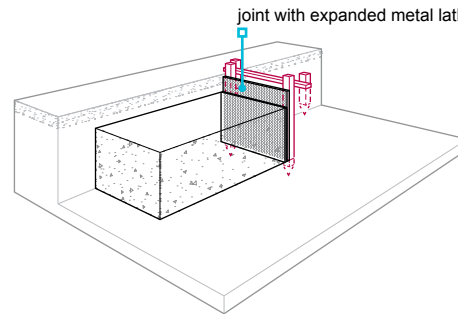

Figure 13: Construction joint formed using expanded metal lath



4.3.14 Further information

- *BS8103-1 Structural design of low-rise buildings. Code of practice for stability, site investigation, foundations, precast concrete floors and ground floor slabs for housing*



Chapter

4.4



Raft, pile, pier and beam foundations

This chapter gives guidance on meeting the Technical Requirements for raft, pile, pier and beam foundations.

4.4.1	Compliance	02
4.4.2	Provision of information	02
4.4.3	Site conditions	02
4.4.4	Hazardous ground	03
4.4.5	Services and drainage	03
4.4.6	Safe transmission of loads	04
4.4.7	Construction	04
4.4.8	Engineer checks	06
4.4.9	Compressible materials	06
4.4.10	Reinforcement	06
4.4.11	Concrete	06
4.4.12	Movement joints	06
4.4.13	Resistance to moisture	07
4.4.14	Further information	07

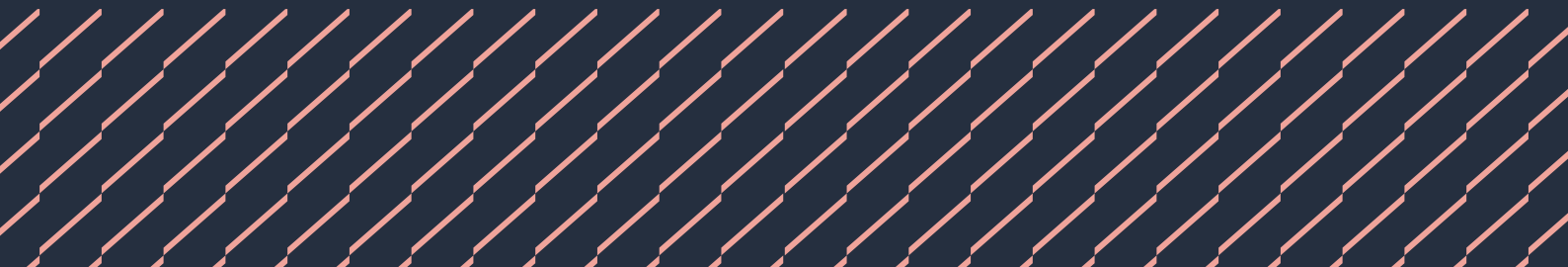

Figure reference table**Figure Reference Table 4.4**

Fig No	Title/Description	Clause	Page
Figure 1	Minimum pile setting out requirements	4.4.7.1	5
Figure 2	Minimum foundation setting out requirements	4.4.7.1	5
Figure 3	Typical DPC detail to an external wall at ground level where a suspended ground floor is used over a piled foundation	4.4.13	7
Figure 4	Typical DPC detail to an external wall at ground level when built off a raft foundation	4.4.13	7

4.4.1 Compliance

Also see: Chapter 2.1

Raft, pile, pier and beam foundations shall comply with the Technical Requirements and provide adequate support to load-bearing elements.

Raft, pile, pier and beam foundations that comply with the guidance in this chapter will generally be acceptable.

Relevant Standards and codes of practice include:

BS 8004	Code of practice for foundations
BS EN 1991	Actions on structures
BS EN 1992	Design of concrete structures
BS EN 1997-1	Geotechnical design — General rules
BS 10175	Investigation of potentially contaminated sites. Code of practice

Elements of the building requiring foundations include:

- external walls
- separating (party) walls
- internal load-bearing walls
- chimney breasts
- piers
- sleeper walls
- internal masonry walls.

4.4.2 Provision of information

Designs and specifications shall be produced in a clearly understandable format, include all relevant information and be distributed to all appropriate personnel.

All dimensions and levels should be indicated and relate to at least one benchmark and reference point on site. Design and specification information should be issued to site supervisors, relevant specialist subcontractors and/or suppliers, and include the following information:

- dimensions, type and depth of foundations
- detailing of ducts
- junctions
- steps
- movement and construction joints
- location of services
- critical sequences of construction.

Both designers and site operatives need to be aware of:

- ground conditions
- any features requiring special attention, such as existing sewers or other services
- water table levels
- the presence of any hazardous substances, including sulfates.

4.4.3 Site conditions

Also see: Chapters 5.2 and 4.1

Raft, pile, pier and beam foundations shall be designed to take account of site conditions. Issues to be taken into account include:

- | | |
|---|---|
| 1) the results of the site and ground appraisal | 4) frost susceptible soils |
| 2) dwelling design, layout and site levels | 5) potential for differential settlement. |
| 3) trees and hedges | |

4.4.3.1 Site and ground appraisal

All information relating to the site and its ground conditions which is necessary for full and proper foundation design should be obtained.

Building over changes in ground characteristics should be avoided.

4.4.3.2 Dwelling design, layout and site levels

Foundation design should take account of site layout, shape, size and construction of the dwelling.

Stepped foundations and suspended floors may be required for sloping sites.

4.4.3.3 Trees and hedges

Where the soil is shrinkable and nearby trees and hedges are existing, proposed or have been recently removed, foundations should be designed as shown in Chapter 4.2 Building near trees.

4.4.3.4 Frost susceptible soils

To avoid damage from frost action, the depth to the underside of the foundation in frost susceptible ground should be at least 450mm below finished ground level.

4.4.3.5 Differential settlement

Foundations should be designed to avoid any local stress points or any differential settlement.

Foundations for terraced homes, or those adjoining an existing building, may require special precautions to prevent damage from differential settlement. Foundations for attached bays, porches, garages, conservatories and other structures should be a continuation of those for the main home, unless the design indicates an alternative which takes account of differential movement.

4.4.4 Hazardous ground

Also see: Chapters 3.1, 4.1, 4.2 and BRE Special Digest 1

Raft, pile, pier and beam foundations shall take account of ground conditions and hazards. Where hazardous ground has been identified, notice shall be given to NHBC before work commences.

Where there is hazardous ground, the design of foundations must be carried out by an engineer in accordance with Technical Requirement R5.

Where hazardous ground has been identified, NHBC should be notified in writing at least eight weeks before work on site begins, in accordance with NHBC Rules.

Where toxic materials, or those likely to present a health hazard, are found, all available information should be supplied to NHBC, together with proposals for remediation.

Sulfate and acids

Sulfates and other chemicals can cause expansion and disruption of concrete. High acidity, for example in peat, or permeable soil with acidic groundwater can cause damage to concrete. Where sulfates or high acidity in ground or groundwater are present, reference should be made to Chapter 3.1 Concrete and its reinforcement for guidance concerning acceptable concrete mixes.

Where concrete is at risk from chemical attack from the ground, or where the groundwater is highly mobile, the level of sulfate and other chemicals should be determined in terms of the ACEC class (aggressive chemical environment for concrete class), in accordance with BRE Special Digest 1.

4.4.5 Services and drainage

Also see: Chapters 5.1, 5.3 and 8.1

Raft, pile, pier and beam foundations shall take account of new and existing services. Issues to be taken into account include:

1) provision for new services

2) adequate protection of existing services and drainage.

4.4.5.1 Provision for new services

Where services are to pass through, above or under foundations, openings should be provided using suitable ducts, sleeves or lintels that:

- are detailed so as not to impair structural stability
- do not affect the ability of the foundation to carry loads
- make suitable provision to allow for movement
- have sufficient space to maintain line and gradient of drainage where movement occurs.

4.4.5.2 Existing services and drainage

Existing services or drains should:

- be supported and protected
- be bridged, to prevent any load carrying
- not be rigidly encased in concrete, masonry, etc.

Land drains should be diverted to a suitable outfall; other drains should be diverted or bridged.

4.4.6 Safe transmission of loads

Also see: Chapter 4.6

Raft, pile, pier and beam foundations shall be designed to transmit loads from the structure to the ground safely, without excessive settlement.

Raft, pile, pier and beam foundations should safely transmit loads. The following issues should be taken into account:

- adequate stiffness to ensure that differential movement does not adversely affect the supported structure
- nature and bearing capacity of the fill material to be placed under the foundation
- specification of concrete and cover to reinforcement.

Raft and semi-raft foundations

Raft and semi-raft foundations should be designed:

- to prevent the erosion of ground beneath the raft
- (where required) to accommodate warm air ducts, service ducts or services without any adverse effect upon the performance of the foundation
- to limit the risk of ducts becoming flooded
- to support the building envelope without the risk of differential movement between leaves of cavity walls.

Fill for raft foundations should be in accordance with Chapter 4.6 Engineered fill.

Semi-raft foundations on engineered fill

The following notes are to be used as a guide for engineers designing raft foundations, but are by no means exhaustive. Special consideration will be required for certain sites.

- raft foundations are to be designed by a chartered civil or structural engineer, taking account of ground conditions and the results of the site appraisal and ground assessment
- sufficient internal beams are to be provided to stiffen the slab adequately
- the area between downstand beams should not be greater than 35m²
- the ratio of adjacent sides on plan should not exceed 2:1
- the minimum depth of perimeter and party wall beams is to be 450mm. On larger homes, some internal beams should be of the same depth as the perimeter beams
- perimeter and internal beams should be sufficiently wide at their base to carry their total loading at the allowable bearing pressure for the site
- beams are to be designed to span 3m simply supported and cantilever 1.5m
- beams are to use properly formed reinforcement in accordance with BS EN 1992-1-1
- where mesh is used in beams, it should be delivered to the site pre-bent
- all beams should be cast on a minimum of 50mm concrete blinding
- minimum cover to reinforcement should be 40mm
- floor slabs should be a minimum 150mm thick, with nominal top face reinforcement as a minimum and anti-crack reinforcement in the bottom face, where appropriate
- stools or similar should be used to support floor slab mesh during casting
- corners and junctions to beams should be adequately tied using similar reinforcement to the beams
- a minimum cavity drain of 225mm below the DPC is to be maintained.

Piled foundations

The design of all piled foundations should specify precautions for cohesive soils where volume changes can occur.

The bearing capacity and integrity of piles should be confirmed by testing, when required.

4.4.7 Construction

Also see: Chapter 4.2

Raft, pile, pier and beam foundations shall be constructed in accordance with the design. Issues to be taken into account include:

- 1) setting out and excavations
- 2) localised effects and trench bottoms
- 3) installation of piles, piers and ground beams
- 4) load capacity verification of piles.

4.4.7.1 Setting out and excavations

The accuracy of setting out should be checked by control measurements of trenches, including their location relative to site boundaries and adjacent buildings. Levels should be checked against benchmarks, where appropriate. For excavations, check:

- trench lengths
- trench widths
- length of diagonals between external corners.

In addition, for piled, pier and beam foundations, check:

- spacing
- alignment
- positions in relation to the proposed superstructure.

Walls should be located centrally on the foundation, unless specifically designed otherwise. Inaccuracy may prevent walls and piers being located centrally, resulting in eccentric loading and possible foundation failure.

Discrepancies to the design of the foundations or variations in the ground conditions should be reported formally to the engineer.

Variations in design or ground conditions should be recorded and distributed to NHBC and others concerned with sitework.

Foundation excavations should:

- be kept free from water
- not be excessive.

Figure 1: Minimum pile setting out requirements

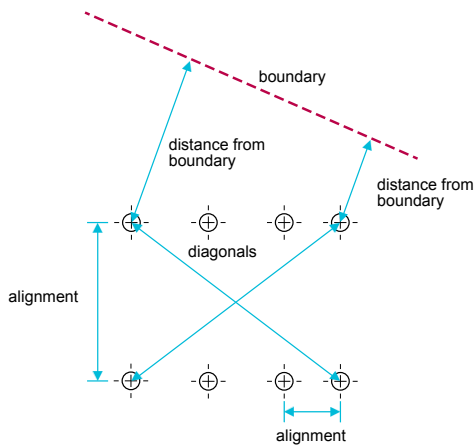
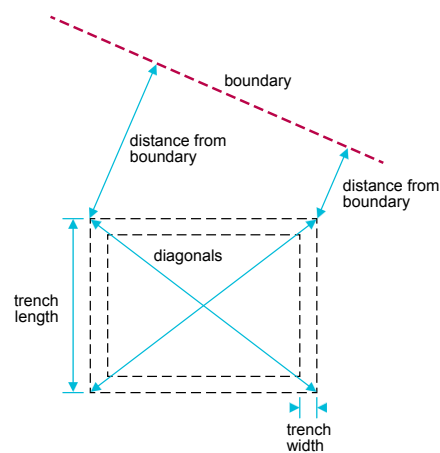

Figure 2: Minimum foundation setting out requirements



4.4.7.2 Localised effects and trench bottoms

Trench bottoms affected by rainwater, groundwater or drying should be rebottomed to form a sound surface.

Table 1: Localised effects

Situation	Action
Differences in bearing capacity (eg from localised changes in strata)	Consult the engineer
Soft spots	Excavations should be deepened locally to a sound bottom, or the concrete should be reinforced
Hard spots	Should be removed
Visible roots, especially in clay soils	Consult the engineer and modify the design depth

4.4.7.3 Installation of piles, piers and ground beams

Piles are to be installed by an appropriate specialist and under the supervision of an engineer.

Piles are to be vertical, unless designed otherwise.

Where piles are more than 75mm out of position, or out of alignment by more than 1:75, the engineer should reconsider the adequacy of the foundation design.

Where piles are misaligned by more than 150mm in any direction, or more than 5° from their specified rake, they should be replaced, unless otherwise recommended by the engineer. Alternatively, additional piles should be provided in accordance with the design modifications provided by the engineer.

Care should be taken to ensure that the bond of beams to piers and piles is in accordance with the design and is adequate.

4.4.7.4 Load capacity verification of piles

Test loading of piles should be undertaken when required. The builder is to obtain written confirmation that the piles are suitable for their design load.

4.4.8 Engineer checks

Engineer-designed foundations shall be inspected by the engineer during construction.

The engineer should undertake site visits to ensure that the design of the foundation is suitable for the actual ground conditions encountered, and that the construction is in accordance with the design.

4.4.9 Compressible materials

Also see: Chapter 4.2

Compressible materials shall be capable of absorbing potential heave forces.

Materials used to accommodate heave should be assessed in accordance with Technical Requirement R3, and used in accordance with the manufacturer's recommendations and independent assessment when applicable.

Depending on the type of material used, the thickness of the material adopted should take account of the minimum void required, and the residual thickness of the material when compressed.

4.4.10 Reinforcement

Reinforcement of raft, pile, pier and beam foundations shall be in accordance with the design, sufficient to ensure the safe transfer of loads and suitable for localised ground conditions.

Reinforcement should be:

- appropriately sized
- placed correctly
- clean and free from loose rust
- secured at laps and crossings
- properly supported to ensure that the cover indicated in the design is maintained.

Reinforcement may be necessary, for example at construction joints or over small localised soft spots or changes in bearing strata.

4.4.11 Concrete

Concrete for raft, pile, pier and beam foundations shall be:

- | | |
|--|---------------------------------------|
| 1) of a suitable mix design to achieve the required strength and resistance to chemical and frost action | 2) correctly mixed, placed and cured. |
|--|---------------------------------------|

Mixing, placing, testing and curing of concrete should be carried out as indicated in Chapter 3.1 Concrete and its reinforcement; and when work is carried out in cold weather, Chapter 3.2 Cold weather working.

4.4.11.1 Suitable mix

Concrete should be of a mix which:

- will achieve the required strength and not impair the performance of the foundation
- is sufficiently resistant to chemical and frost action.

4.4.11.2 Correctly mixed, placed and cured

Before concrete is placed, excavations and reinforcement may need to be approved by the engineer or their representative. In England and Wales, foundations should be approved by the person responsible for building control inspections.

Concreting should:

- be carried out in one operation (as far as possible)
- take account of weather conditions and available daylight
- be placed as soon as possible after the excavation or after the reinforcement has been checked
- be placed in even, compact and reasonably dry trenches.

4.4.12 Movement joints

Raft, pile, pier and beam foundations shall have movement joints suitable for their intended purpose and be formed using appropriate materials.

Movement joints should be located so as to limit the risk of damage caused by movement. The design of movement joints and choice of sealing materials should consider:

- anticipated movement
- movement capability of seal
- designed joint width
- actual joint width
- joint depth
- surface preparation
- backing medium
- projected life span of the joint.

4.4.13 Resistance to moisture*Also see: Chapters 5.1, 5.2 and 5.4*

Raft, pile, pier and beam foundations shall prevent the passage of moisture to the inside of the home and, where necessary, include a drained cavity and damp proof membranes.

Cavity walls should drain below the DPC and should:

- prevent water crossing from the outside to the inside
- prevent the flooding of cavities above the DPC
- have a minimum 225mm clear cavity below the DPC where strip, trenchfill or ground beams are used, or have a minimum 150mm clear cavity below the DPC where other types of foundations are used, provided that weepholes and other necessary measures are taken to ensure that the cavity can drain freely.

DPC cavity trays are not an acceptable waterproofing to the edges of specialised foundations, such as rafts and ground beams.

Figure 3: Typical DPC detail to an external wall at ground level where a suspended ground floor is used over a piled foundation

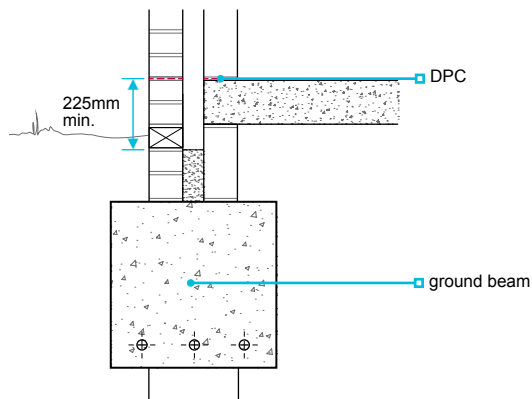
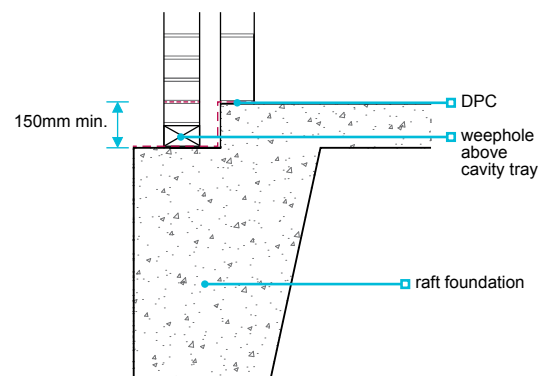



Figure 4: Typical DPC detail to an external wall at ground level when built off a raft foundation

**4.4.14 Further information**

- *BRE Special Digest 1 — Concrete in aggressive ground. 3rd edition*



Chapter 4.5



Vibratory ground improvement techniques

This chapter gives guidance on meeting the Technical Requirements and recommendations for vibratory ground improvement techniques.

4.5.1	Compliance	02
4.5.2	Provision of information	02
4.5.3	Hazardous sites and ground hazards	02
4.5.4	Desk study and site investigation	03
4.5.5	Confirmation of suitability for treatment	03
4.5.6	Suitability of ground conditions	04
4.5.7	Compatibility of the ground, design and treatment	06
4.5.8	Acceptable methods	08
4.5.9	Materials for use as fill	08
4.5.10	Granular material	09
4.5.11	Sitework	09
4.5.12	Adjacent excavations	11
4.5.13	Verification of completed treatment	11
4.5.14	Further information	13



Figure reference table

Figure Reference Table 4.5

Fig No	Title/Description	Clause	Page
Figure 1	Ground subject to settlement	4.5.6.1	5
Figure 2	Stone column acting as vertical vent	4.5.6.1	5
Figure 3	Vibro foundation depth in volume change potential soils	4.5.6.2	6
Figure 4	Interaction of foundations in close proximity	4.5.6.2	6
Figure 5	Stone column acting as vertical drains	4.5.6.2	6
Figure 6	Effect of depressed water level on adjacent building	4.5.6.3	6
Figure 7	Effect of raised water level on adjacent building	4.5.6.3	6
Figure 8	Building located over changing ground conditions	4.5.7.1	7
Figure 9	Assessing the effect of load distribution on foundations with corresponding settlement characteristics	4.5.7.1	7
Figure 10	Potential location of bed-joint reinforcement in masonry walls	4.5.7.2	7
Figure 11	Reinforced concrete strip foundation detail	4.5.7.3	7
Figure 12	Raft or semi-raft foundation detail	4.5.7.3	7
Figure 13	Vibratory dry bottom feed method	4.5.8	8
Figure 14	Vibratory dry top feed method	4.5.8	8
Figure 15	Ideal setting out of vibro columns	4.5.11.2	10
Figure 16	Setting out of vibro columns requiring corrective action	4.5.11.2	10
Figure 17	Examples of unforeseen changes or trends during execution of vibro treatment	4.5.11.3	10
Figure 18	Placement of excavation adjacent foundation on vibro treatment	4.5.12	11
Figure 19	Mini zone testing using skip	4.5.13.1	12
Figure 20	Full zone testing simulating actual foundation load	4.5.13.1	12

Introduction

The vibratory process is generally applied to weak natural soils and filled ground. The purpose is to improve the load-bearing capacity, reduce settlement and provide an adequate bearing stratum for the foundation supporting the home.

4.5.1 Compliance

Also see: Chapter 2.1

Vibratory ground improvement techniques shall comply with the Technical Requirements and be designed by an engineer in accordance with established standards and codes of practice.

Vibratory ground improvement techniques that comply with the guidance in this chapter, and that are in accordance with the relevant British Standards, Building Regulations and statutory requirements, will generally be acceptable.

Design of vibratory ground improvement, including foundations, should be carried out by an engineer experienced in ground improvement techniques in accordance with Technical Requirement R5. In this chapter, the term ‘engineer’ refers to an appropriate engineer who is independent of the contractor responsible for the vibratory ground improvement techniques.

British Standards, codes of practice and authoritative documents relevant to vibratory ground improvement techniques and site investigations include:

BS 10175	Investigation of potentially contaminated sites. Code of practice
BS EN 1991	Actions on structures
BS EN 1997-1	Geotechnical design — General rules
BS EN 1997-2	Geotechnical design — Ground investigation and testing
BS EN 14731	Execution of special geotechnical works. Ground treatment by deep vibration
BS EN ISO 14688	Geotechnical investigation and testing. Identification and classification of soil
BS EN ISO 14689	Geotechnical investigation and testing. Identification and classification of rock
BS EN ISO 22476	Geotechnical investigation and testing. Field testing
BR 391	Specifying vibro stone columns
ICE	Specification for Ground Treatment

4.5.2 Provision of information

Design and specifications shall be produced in a clearly understandable format, including all relevant information and shall be distributed to all appropriate parties.

The vibratory improvement proposal and accompanying information including relevant drawings should be submitted to NHBC at least eight weeks prior to the commencement of the vibratory process or associated works.

All dimensions and levels should be indicated and relate to at least one benchmark and reference point on site. Design and specification information should be issued to site supervisors, relevant specialist subcontractors and/or suppliers, and include the following information:

- dimensions, type and depth of treatments
- detailing of ducts
- junctions
- steps
- movement and/or construction joints
- location of services
- critical sequences of construction.

Both designers and site operatives need to be aware of:

- ground conditions
- any features requiring special attention, such as existing sewers or other services
- water table levels
- the presence of any hazardous substances or unsuitable ground conditions.

This list is not exhaustive and additional content may be required depending on site specific circumstances.

4.5.3 Hazardous sites and ground hazards

Also see: Chapters 2.1, 4.1 and 4.2

Vibratory ground improvement techniques on hazardous sites shall be reported to NHBC before work on site commences, and be designed to take account of the characteristics of the site, including any ground hazards.

Hazardous sites, as defined in the NHBC Rules, should be reported to NHBC in writing at least eight weeks before sitework begins.

Details of ground hazards to be taken into consideration are given in Chapter 4.1 Land quality — managing ground conditions and Chapter 4.2 Building near trees.

4.5.4 Desk study and site investigation

Also see: Chapters 2.1, 4.1 and 4.2

The engineer shall ensure a desk study and site investigation are undertaken and findings used to inform the design.

The engineer should establish the scope of, and supervise, the site investigation, taking account of the findings of the desk study, and relevant standards listed in Clause 4.5.1.

The specialist contractor should be satisfied that the site investigation provides adequate and representative information in order to design the ground improvements. The results of the site investigation and desk study should be sent to NHBC prior to work starting and should, as a minimum, determine the items listed in Table 1.

Table 1: Results of the site investigation and desk study

Item to be determined	Guidance
Depths and properties of natural materials under the site	Includes the presence of caves, workings, or natural phenomena such as rocks or soils which dissolve or erode when exposed to the passage of water. Data for comparison with post-treatment properties should be established.
Extent and nature of any areas of filled ground on the site	Includes: <ul style="list-style-type: none"> • proportions and distribution of constituent materials • state of compaction of the fill material throughout its depth • grading and particle size distribution of fill materials • potential for gas generation from fill materials • potential for spontaneous combustion of fill and/or natural deposits.
Presence and extent of any existing or redundant services and drains	Includes information on the extent and nature of the backfill to the excavations.
The effect of sustainable drainage system (SuDS)	Includes the effect that any SuDS may have on the geotechnical parameters of the site.
Presence, level and nature of any groundwater	Includes the potential for groundwater to rise and cause heave or collapse by saturation.
Previous structures	Includes any potential underground obstructions or hard spots, eg basement walls, floor slabs, which remain.
Occurrence of contaminated substances	Includes the presence and extent of contaminated substances or gases present or suspected.

4.5.5 Confirmation of suitability for treatment

Also see: Chapters 2.1, 4.1 and 4.2

The builder shall obtain written confirmation from the engineer and specialist contractor that the site is suitable for the proposed ground improvement system.

NHBC should be notified prior to work starting, that the site is suitable for the proposed system. The engineer and specialist contractor should agree the following in writing before work commences on site:

- design objectives
- detailed schedule of work
- programme of work
- tests to be conducted on completion of the work
- responsibility for procedures and tests.

The following considerations should be taken into account:

- layout and depth of the stone columns and the accuracy to be achieved
- safety issues to be incorporated into the design to allow for unforeseen circumstances
- criteria for non-acceptance of the vibrating poker work tests to be conducted on completion of the work
- responsibility for procedures and tests
- calculations and case histories required to justify the ground improvement proposals together with the layout of the stone columns and details of the equipment and process to be used on site.

These written agreements should be made available to NHBC before work commences on site.

4.5.6 Suitability of ground conditions

Also see: Chapters 2.1, 4.1 and 4.2

Vibratory ground improvement techniques shall only be conducted on suitable ground and be appropriate for the site conditions. Issues to be taken into account include:

- 1) unsuitable ground conditions
- 2) detrimental factors
- 3) groundwater conditions.

The engineer should assess the ground and be satisfied that it is suitable for treatment. Conditions acceptable for treatment are only those within zones A and B of Chart 1.

Chart 1: Conditions acceptable for treatment

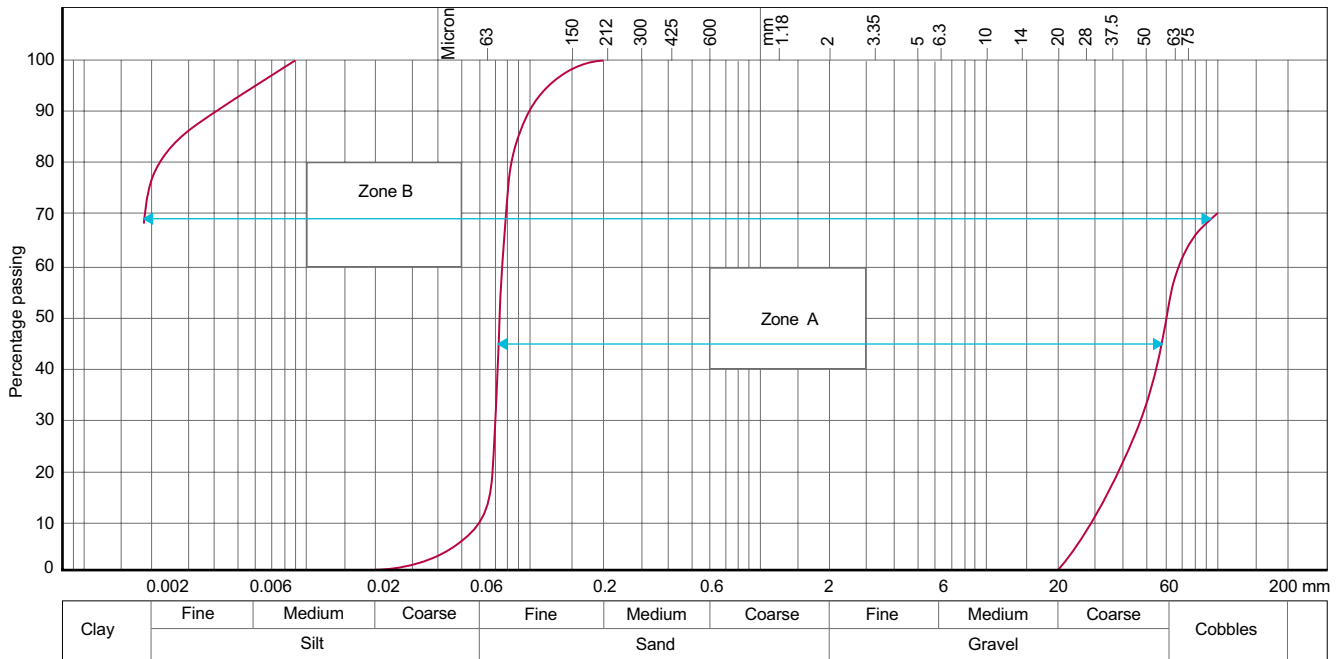

Zone A – range of materials suitable for deep compaction (vibro-compaction) techniques.

Zone B – range of materials suitable for stone column (vibro-replacement) techniques.

4.5.6.1 Unsuitable ground conditions

Table 2: Ground conditions not generally acceptable for treatment

Soil composition	
Clays	Ground with a Plasticity Index greater than 40%
Soft clays	Ground with soft clays with an undrained shear strength less than 30kN/m ² For clay strength less than 30kN/m ² , additional consideration must be given to group effects, ground heave and settlement due to installation. Any proposals will be subject to NHBC agreement
Ground with peat layers	Ground with peat layers close to foundation level or the base of the stone column, or where intermediate layers of peat are thicker than 200mm either as a single layer, or the sum of the thicknesses of individual layers, throughout the length of the stone column
Highly sensitive soils	Ground liable to collapse or remoulding
Ground with fill	
Voided filled ground	Ground which includes, for example, old water tanks, pottery, glass bottles, concrete rubble or brick fill of unsuitable grading
Loose or non-engineered fill	Ground with any loose or non-engineered fill not previously subject to rising or fluctuating water levels or saturation
Filled ground which is still settling or expected to settle	Ground subject to settlement or settling: <ul style="list-style-type: none"> • under its own weight or due to the effects of surcharging/upfilling • where there is a high organic content • where decay is continuing
Fill containing degradable material	Ground where organic material forms more than 15% of fill by volume
Highly contaminated ground	
Ground which includes, for example toxic waste, or where inflammable, explosive or toxic gas generation may take place	Stone columns may act as vertical vents. Consideration will be given to proprietary systems which do not permit vertical venting such as vibro concrete plug technology.

Figure 1: Ground subject to settlement

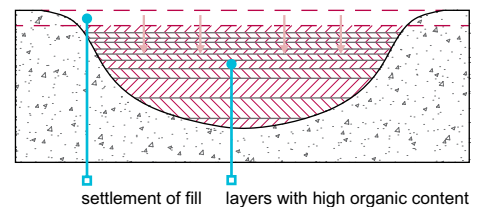
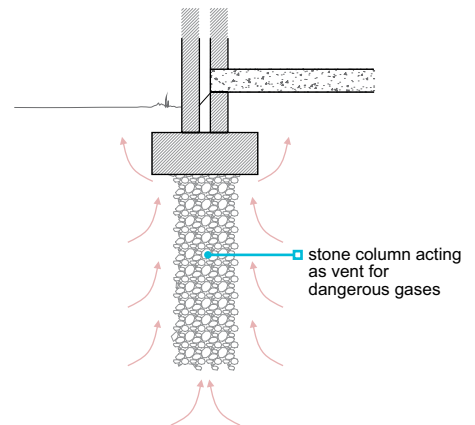

Figure 2: Stone column acting as vertical vent



4.5.6.2 Detrimental factors

When specifying vibratory ground improvement techniques, the following factors should be considered:

- partial depth treatment of filled ground. The engineer should be satisfied with the anticipated performance of both the treated and untreated zones
- the specialist contractor should take responsibility for the treated zone and the depth of treatment
- alterations to the oversite level before or after treatment, or the disturbance of ground by excavations after treatment
- soils with a Modified Plasticity Index of 10% or greater; foundations should be designed to accommodate volume changes (Figure 3)
- obstructions and variations in the density of fill and natural ground (hard spots) and the location of changes in the profile of the natural underlying ground, eg edges of pits or quarries, slopes, or manmade obstructions such as soakaways or drainage runs
- the minimum depth of soil treated, which should allow for the interaction of adjacent foundations (Figure 4)
- stone columns that may form vertical drains, allowing the passage of water to a moisture-susceptible strata, or provide seepage paths for gases (Figure 5).

Figure 3: Vibro foundation depth in volume change potential soils

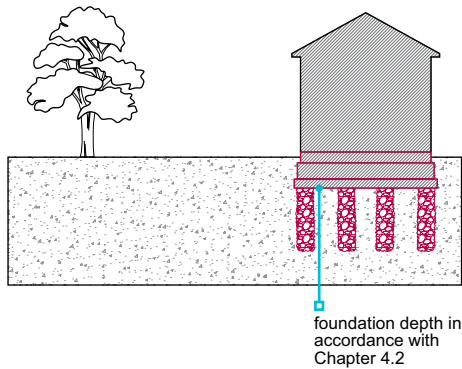

Figure 4: Interaction of foundations in close proximity

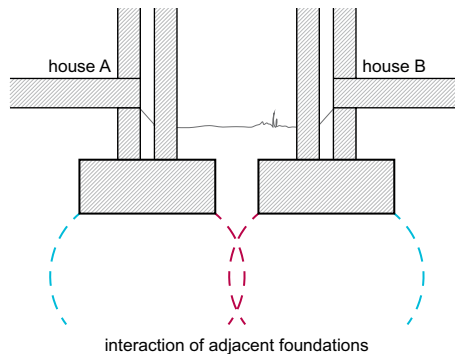
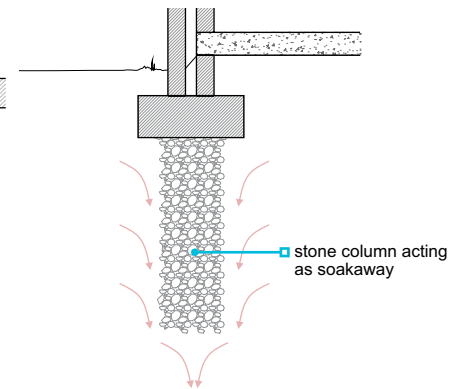

Figure 5: Stone column acting as vertical drains



4.5.6.3 Groundwater conditions

When specifying vibratory ground improvement techniques, the following factors should be considered:

- long-term lowering of the water table causing settlement of existing adjacent buildings
- short-term rise in local water table due to large volumes of water used in wet process during construction causing settlement or heave of existing adjacent buildings.

Figure 6: Effect of depressed water level on adjacent building

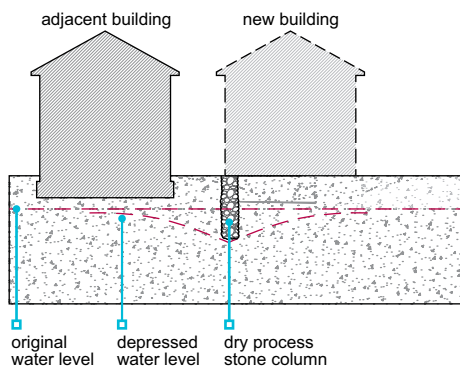
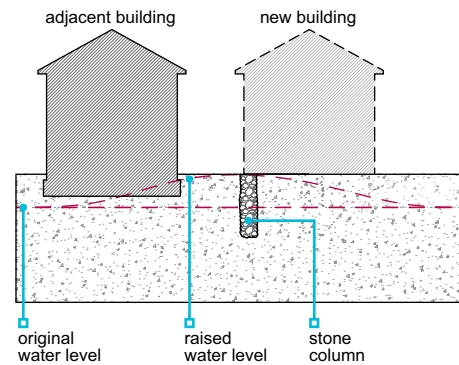

Figure 7: Effect of raised water level on adjacent building



Surface water sewers should be used for rainwater disposal where possible, but where soakaways are necessary, they should be positioned so that their construction and operation is not detrimental to the treated ground.

The effect of any new or existing sustainable drainage systems (SuDS) should be taken into account when vibro compaction improvement techniques are proposed.

4.5.7 Compatibility of the ground, design and treatment

Vibratory ground improvement techniques shall be compatible with the treated ground, site layout and the home design. Issues to be taken into account include:

- 1) limitations of the treated ground
- 2) limitations of ground support
- 3) suitable foundation types
- 4) use of suspended ground floors
- 5) notice to NHBC.

4.5.7.1 Limitations of the treated ground

The engineer should:

- avoid siting homes in locations where major changes in ground conditions can be expected
- consider limitations of the configuration of the homes, including the vulnerability at junctions and of long blocks
- determine the loads to be imposed by the homes, and assess them against the results of the site investigation
- discuss the feasibility of proposals with the specialist contractor
- confirm the required load and settlement performance of the treated ground
- advise and discuss design criteria with NHBC at the design stage.

Figure 8: Building located over changing ground conditions

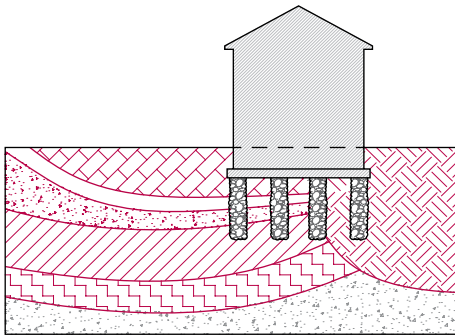
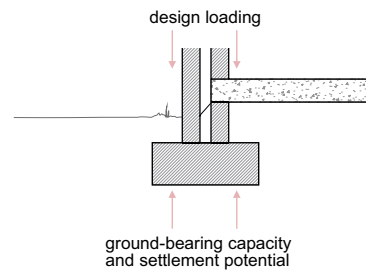

Figure 9: Assessing the effect of load distribution on foundations with corresponding settlement characteristics



4.5.7.2 Limitations of ground support

The engineer should establish the likely limits of ground movement and account for this in the design, including:

- the position and spacing of movement joints
- the flexibility of masonry mortars
- masonry reinforcement.

Figure 10: Potential location of bed-joint reinforcement in masonry walls

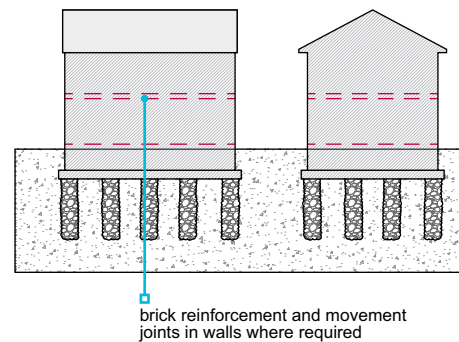

4.5.7.3 Suitable foundation types

The following criteria should be incorporated in the foundation design to ensure the compatibility and overall stability of the foundations and superstructure.

Only two types of foundations are suitable, both of which should comply with the minimum criteria for areas of reinforcement as defined in BS EN 1992-1-1. They are:

- reinforced concrete strip foundation
- reinforced concrete raft or semi-raft foundation positioned on a uniformly compacted bed of hardcore.

Figure 11: Reinforced concrete strip foundation detail

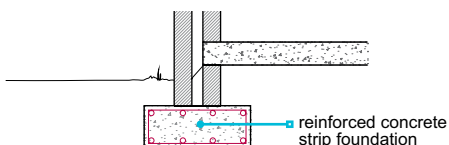

- for both types of foundation, top and bottom reinforcement should be provided
- the depth of foundations to be a minimum of 600mm below the surface of the treated ground, and founded on firm material of adequate bearing capacity
- where the treated ground is of a granular nature, a reinforced concrete strip foundation will normally be acceptable, provided that the full depth of all fill material is treated
- if the treated ground is of a cohesive nature, a suitably designed raft, semi-raft or reinforced concrete strip foundation will normally be acceptable

Figure 12: Raft or semi-raft foundation detail

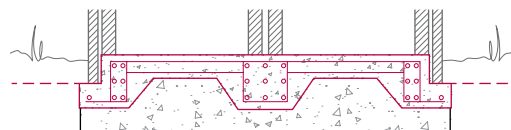

- the reinforced concrete foundation should be designed to span between the centres of adjacent stone columns, unless a more rigorous structural analysis is carried out to show that an alternative detail is acceptable
- if partial depth treatment of filled ground is proposed, a suitably designed reinforced concrete raft or semi-raft foundation should be used
- if, during excavations for foundations in treated ground, it is found that excessive depths of concrete are required, then precautions should be taken to ensure overall stability of the foundations, and the engineer should be satisfied that construction of the foundation will not be detrimental to the treated ground.

4.5.7.4 Use of suspended ground floors

Suspended ground floors should be provided for all homes where vibratory ground improvement has been conducted, unless the engineer can substantiate an alternative solution that is acceptable to NHBC.

4.5.7.5 Notice to NHBC

Where vibratory ground improvement is proposed, NHBC should be informed of:

- proposed development
- proposed start date of treatment.
- appointment of the specialist contractor

4.5.8 Acceptable methods

Vibratory ground improvement techniques shall only be conducted using methods that are appropriate to the ground conditions and acceptable to NHBC.

There are two main vibratory methods commonly used in the UK. These are known as the 'dry bottom feed' and 'dry top feed' methods. A third method, infrequently used in the UK and known as the 'wet bottom feed' is also acceptable to NHBC.

Dry bottom feed method

The dry bottom feed method is adopted in weaker soils or situations where there is a high water table and the borehole is liable to collapse between vibrator insertions.

The vibrator penetrates by its mass, air flush and vibration. At design depth, the stone is introduced via a hopper into a pipe fixed to the side of a vibrator. The stone, generally of 40mm size, exits the pipe at the tip of the vibrator and discharges in to the bottom of the borehole. The stone is then compacted into the surrounding soil by repeated withdrawal and insertion of the vibrator.

Dry top feed method

The dry top feed method is only used on cohesive soils where the borehole can remain open. The vibrator penetrates the weak soil, or fill, by its mass, air flush and vibration to form a borehole.

Once refusal or design depth is reached, the vibrator is removed and stone fill introduced into the borehole, the 'charge' is generally 500-800mm deep. The vibrator is re-inserted and 'packs' the stone into the surrounding strata. Successive charges of stone are added and compacted, bringing the column up to working level. The stone grading is generally 40-75mm.

Figure 13: Vibratory dry bottom feed method

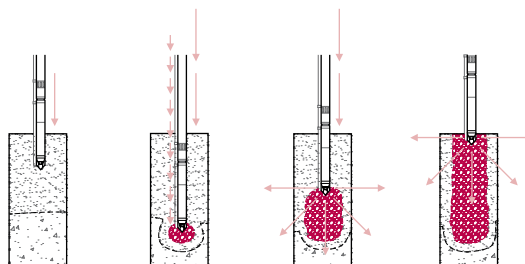
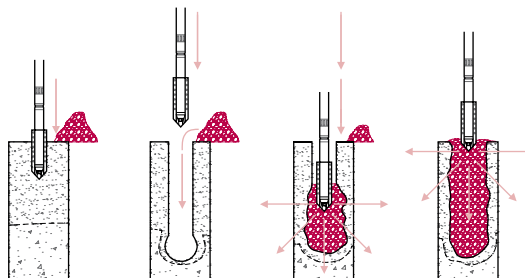

Figure 14: Vibratory dry top feed method



4.5.9 Materials for use as fill

Also see: BRE Special Digest 1 Part 1, BRE Digest 433 and BS EN 771

Stone fill for forming columns shall be compatible with the ground conditions, and be suitable for the vibratory ground improvement process.

Column fill should be a clean, hard, inert material. Limestone fill may not be acceptable in acidic ground conditions.

Suitable sources for fill material

All material used for fill should be suitable.

Where the material is of a stable and uniform type from one source, it may only be necessary to check its suitability once. Regular inspections and/or testing may be required where material is variable or from a number of sources.

Where material is obtained from stockpiles, the uniformity should be checked. Different forms of stockpiling can affect particle size and grading. The outside of a stockpile may be weathered and may not be the same as unweathered material. The use of recycled aggregate as fill should comply with BRE Digest 433 or other suitable guidance as agreed with NHBC.

Hazardous materials

The following materials require testing to ensure their suitability for use as fill to support structural foundations and slabs, or as backfill to associated trenches:

- acid wastes
- reactive materials
- materials that include sulfates, eg gypsum
- organic materials
- toxic materials
- materials that cause noxious fumes, rot, undue settlement or damage to surrounding materials.

Test requirements for fill material

Tests should be carried out by a suitably qualified person with a detailed knowledge of the:

- material to be tested
- proposed conditions of use.

The samples which are tested must be representative of the true nature of the material. It may be necessary to take a number of samples to find out the material characteristics of the fill.

Sulfate content should be expressed as a percentage SO_4 by weight on the basis of acid soluble testing, taking full account of the recommendations of BRE Special Digest 1 Part 1.

Fill material requiring NHBC acceptance

The following types of fill should not be used unless written agreement has been obtained from NHBC:

- colliery shale and any other residue from mineral extraction
- slags
- furnace ashes and other products of combustion
- material obtained from demolition
- on wet sites, or sites with a high water table, crushed or broken bricks which have no limit on their soluble salt content (as defined in BS EN 771)
- manufactured aggregates using materials from waste treatment plants.

Expansive fill materials

Fill containing expansive material is not acceptable for use as support to structural foundations and slabs, or as backfill to associated trenches.

4.5.10 Granular material

Granular material for raising site levels before treatment, or adding during deep compaction, shall be suitable for compaction and, unless appropriate precautions are taken, be free from hazardous materials.

The grading of material for adding during deep compaction should be within Zone A of Chart 1. Well-graded, inert fill which passes a 100mm x 100mm screen in all directions, and contains less than 10% fine material of silt or clay size, will generally be acceptable for raising site levels.

Precautions, including testing where appropriate, should be taken where hazardous materials are present in fill.

4.5.11 Sitework

When using vibratory ground improvement techniques, the builder shall ensure that the engineer visits the site and provides competent supervision throughout the ground treatment process. Issues to be taken into account include:

- 1) engineer checks
- 2) location, depth and alignment of columns
- 3) managing unforeseen circumstances.

4.5.11.1 Engineer checks

The engineer should provide competent site supervision throughout the ground treatment process and at critical stages, including:

- the inspection of foundation setting out
- the installation of columns during the early stage of the work
- checking of materials
- where installation data differs from design assumptions
- where changes in treatment layout are required.

Some aspects of sitework may be the responsibility of the engineer or their representative, or of the specialist contractor, rather than of the builder.

4.5.11.2 Location, depth and alignment of columns

Supervision should ensure that:

- the minimum required depth of the stone columns is achieved and each one correctly located (the builder should provide sufficient profiles to enable locations to be checked)
- the stone columns are located either centrally under the foundations they are to support or are in the predetermined staggered arrangement, at a maximum of 2m centres and at the intersection of adjacent reinforced concrete strips
- missing stone columns are replaced
- stone columns which are misaligned by more than 150mm in any direction are replaced
- the location of all stone columns is checked by the engineer's representative prior to the specialist plant leaving the site.

Figure 15: Ideal setting out of vibro columns

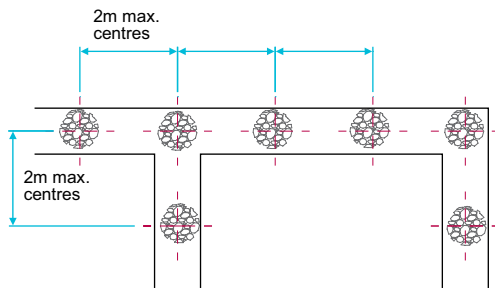
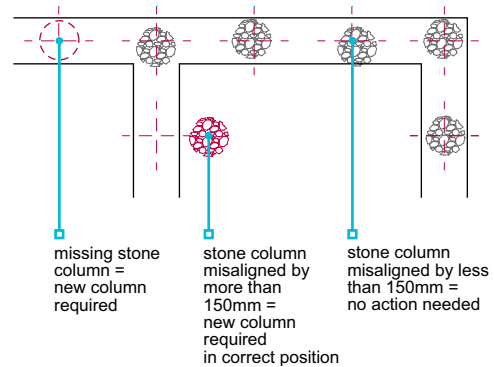

Figure 16: Setting out of vibro columns requiring corrective action



4.5.11.3 Managing unforeseen circumstances

Table 3: Actions for managing unforeseen circumstances

Circumstance	Action	In all cases
Unforeseen changes or trends which affect the site conditions	Recorded and reported to the engineer immediately	Where there is an effect on the final efficiency of the treatment, this should be fully considered by the engineer and the specialist contractor. The builder and NHBC are to be advised immediately regarding proposed remedial measures.
Change in the anticipated depth of the compaction point in excess of 25%	Recorded and reported to the engineer and specialist contractor as soon as possible but no later than the end of the working day of occurrence	
Variation of over 50% in the quantity of backfill used in compaction points of the same length		

Figure 17: Examples of unforeseen changes or trends during execution of vibro treatment

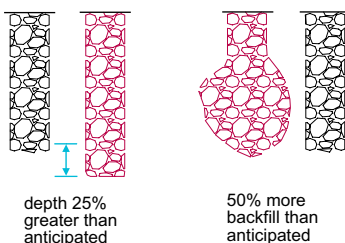

Allowance should be made for unforeseen obstructions that require either local removal and backfilling prior to treatment, realignment or additional columns, coupled with local amendment of foundation design.

4.5.12 Adjacent excavations*Also see: BR 391***The builder shall ensure that foundations are not disturbed by adjacent excavations.**

The engineer should consider the influence of drainage and other service trenches on the stability of the complete design.

The minimum clearance between excavations and foundations must not be less than the depth of excavation minus the depth of the structural foundation. Particular attention is needed for excavation below the water table.

Figure 18: Placement of excavation adjacent foundation on vibro treatment

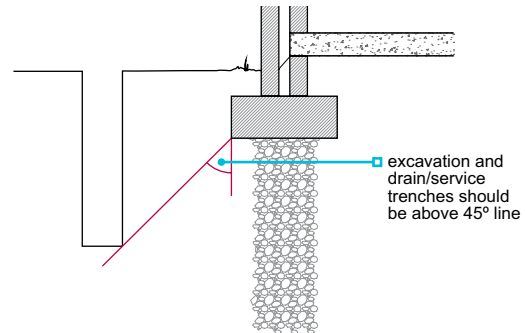
**4.5.13 Verification of completed treatment**

The engineer shall require the specialist contractor to verify that the ground treatment is satisfactory, including:

- 1) suitable testing
- 2) written confirmation of completed treatment
- 3) recording of work.

4.5.13.1 Suitable testing

Tests should be carried out to establish the degree of ground improvement, the load-bearing characteristics and settlement potential.

The specialist contractor should:

- predict the results from their experience of work on the type of ground prior to the test taking place
- agree acceptable results and degree of tolerance with the engineer prior to testing
- confirm that the final results are acceptable with the engineer on receipt and review of actual results.

Where the results are vastly different, a further investigation may be necessary.

Where a threefold improvement was predicted and only a twofold improvement achieved, this could indicate that the ground was different from that identified in the investigation, or that the treatment carried out differed from the specified treatment.

Tests on ground containing clay soils may need to be conducted several days after completion to allow excess pore pressures to dissipate. The engineer may choose any appropriate combination of the tests detailed in Table 4, with the agreement of NHBC.

Table 4: Test methods

Test	Comments
600mm diameter plate tests	<p>Plate tests will not determine the design but will allow for an assessment to be made of the workmanship on the stone columns.</p> <p>The tests should be carried out on stone columns or treated ground at a frequency of at least one test per day per rig.</p>
Dummy footing test/mini zone test	<p>A mini zone test can be used as a limited substitute for zone tests. The test should be applied to at least two stone columns and the area of foundation which they support.</p> <p>The load may be applied through a rigid beam or stiffened plate using skips or other known loads, arranged to give a uniform distribution of the load.</p> <p>Testing frequency should be at least one test per week per rig on normal sites. Where the site is of a geotechnically challenging nature, such as lengthy columns of over 6m or treatment of variable fill or soft/weak natural soils, then additional tests per week per rig will be required.</p> <p>Mini zone tests should be continued for a sufficient time to allow creep behaviour to be quantified. Allowances for this time should be made in the overall project programme.</p>
Zone test	<p>An isolated pad or strip footing is used to test up to eight stone columns and the intervening ground. Loadings which should simulate the dwelling loads are held for 24 hours at predetermined stages to examine creep behaviour.</p>
In-situ test	<p>Where vibration will improve the ground itself, eg granular materials, then in-situ testing is appropriate.</p> <p>Improvement can be assessed when the in-situ test results are compared with the pretreatment investigation.</p>
Trial pits	<p>Trial pits can be excavated around trial stone columns to prove that they are fully formed and to the required depth and diameter.</p> <p>This is a destructive test, and allowance should be made accordingly.</p>

Figure 19: Mini zone testing using skip

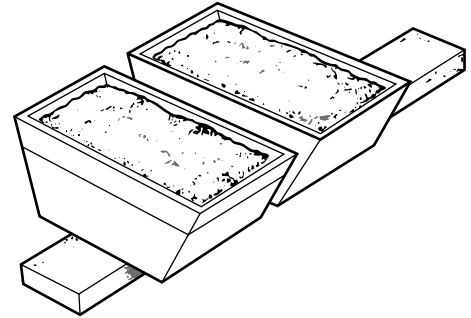
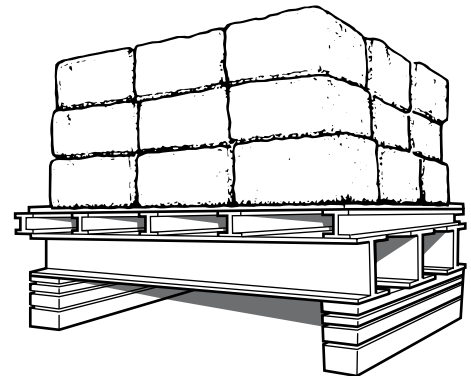

Figure 20: Full zone testing simulating actual foundation load



4.5.13.2 Written confirmation of completed treatment

On completion of the treatment, the engineer should:

- use the test results to verify that the treated ground has achieved the anticipated condition assumed in the design
- advise the builder and NHBC in writing of the verified effectiveness of treatment in relation to the design
- advise the builder of any special precautions which should be taken for the positioning of services both beneath the home and adjacent to it.

4.5.13.3 Recording of work

A comprehensive record of all works should be made available to NHBC, including:

- information concerning the treatment
- depth of fill
- volume of stone used
- on-site changes
- any other relevant information.

4.5.14 Further information

- *BRE Special Digest 1 — Concrete in aggressive ground. 3rd Edition*
- *BRE Digest 391 — Specifying vibro stone columns*
- *BRE Digest 433 — Recycled aggregates*
- *BS EN 771-1 — Specification for masonry units. Clay masonry units*



Chapter 4.6



Engineered fill

This chapter gives guidance on meeting the Technical Requirements and recommendations for using engineered fill to support foundations to residential developments, external works and infrastructure.

4.6.1	Compliance	06
4.6.2	Provision of information	07
4.6.3	Hazardous sites and ground hazards	07
4.6.4	Desk study and ground investigation	07
4.6.5	Suitability of ground conditions	08
4.6.6	Materials for use as engineered fill	10
4.6.7	Design and specification of earthworks	12
4.6.8	Compatibility of fill with foundations, infrastructure and external works	16
4.6.9	Acceptable methods of earthworks filling	20
4.6.10	Site work	21
4.6.11	Adjacent excavations	23
4.6.12	Verification of engineered fill	24
4.6.13	Reporting	27
4.6.14	Further information	28

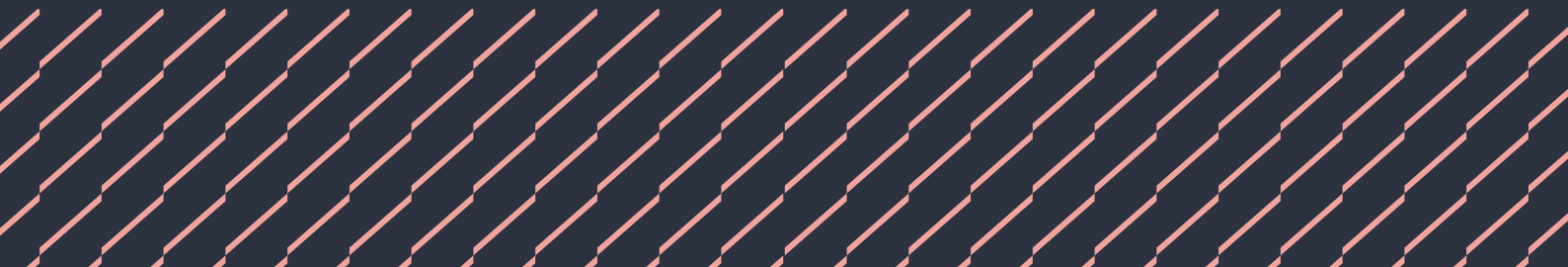

Figure reference table

Figure Reference Table 4.6

Fig No	Title/Description	Chapter/Clause	Page
Figure 1	Fill assessment and chapter applicability process	4.6	3
Figure 2	Compaction and differing end use	4.6.7.3	16
Figure 3	Engineered fill over gentle rolling landscape	4.6.8.3	19
Figure 4	Engineered fill over buried features	4.6.8.3	20
Figure 5	Benching of sloping natural ground	4.6.10.2	22
Figure 6	Placement of excavation adjacent foundation on engineered fill	4.6.11	24
Figure 7	Basis for design: plot of moisture contents vs. dry densities for fill type	4.6.13	28

Introduction

On construction sites, filling or earthworks are often required for various purposes, such as preventing flooding, enhancing drainage, planning roads or establishing a suitable ground profile. Engineered fill may also be used to replace existing made ground overlying competent strata at shallow to moderate depths to form a new development platform, or be used below raft foundations on sites with shrinkable clays and trees in lieu of deep trench fill foundations.

This chapter details the information that NHBC requires to ensure that engineered fill is correctly placed to support low-rise residential building structures, external works, and infrastructure while avoiding potential risks of excessive settlement or ground failure.

Scope

This chapter gives guidance for engineered fill to be placed for the support of the proposed development.

The interaction between engineered fill, underlying ground conditions and the development are important and site-specific. The primary objectives of this chapter are to ensure that:

- the ground investigation is appropriate to the proposed development, site conditions and nature of the filling
- geotechnical ground model(s) are developed, taking into account the proposed development and underlying ground and groundwater conditions
- the engineered fill is placed to a suitable earthworks specification
- appropriate geotechnical laboratory acceptability testing and in-situ, compliance testing is undertaken and documented, and verification is provided to NHBC
- engineered fills do not settle excessively or have the potential to cause excessive differential settlement between properties founded upon the fill and external areas
- engineered fill and the underlying ground supporting building foundations shall limit building settlements to less than 25mm and minimise angular distortion or tilt to 1:400
- the design and detailing of foundations, infrastructure and external works suit the placed fill and underlying ground conditions, taking account of the overall ground model and any geohazards in the ground beneath or nearby.

The geotechnical and environmental suitability of historic fill, or fill placed without full verification reporting, should not be relied upon without appropriate site investigation, characterisation, compliance testing and assessment being undertaken like other made ground deposits would be assessed. This may need to include long-term settlement monitoring or loading trials to determine performance.

Assessment of historic fill within land reclamation schemes and marginal sites is generally outside the scope of this chapter. For sites with uncertainty about their suitability for future residential development, please consult NHBC or consider using NHBC Land Quality Service for a bespoke consultation. You can find details about this service at:

- www.nhbc.co.uk/builders/products-and-services/consultancy/land-quality-service
- Email: lqs@nhbc.co.uk

The following are not considered in this chapter and will require more specific guidance from other sources:

- backfilling to retaining walls, buried features such as culverts, services or access chambers
- capping and sub-bases to roads, drives, parking, and hardstanding areas
- filling beneath adoptable highways
- soil stabilisation or soil mixing
- piling mats or other specific forms of working surface for construction activities
- fill containing hazardous substances or required to provide mitigation against the presence of contamination, or to be placed on contaminated sites
- use of reinforcing geogrids.

The builder is responsible for ensuring that any earthworks filling proposals do not breach planning requirements or waste and environmental regulations.

The following Figure 1 is to assist users in navigating through this chapter and outlines how proposed or existing earthworks fit into the applicability and use of this standard.

Figure 1: Fill assessment and chapter applicability process

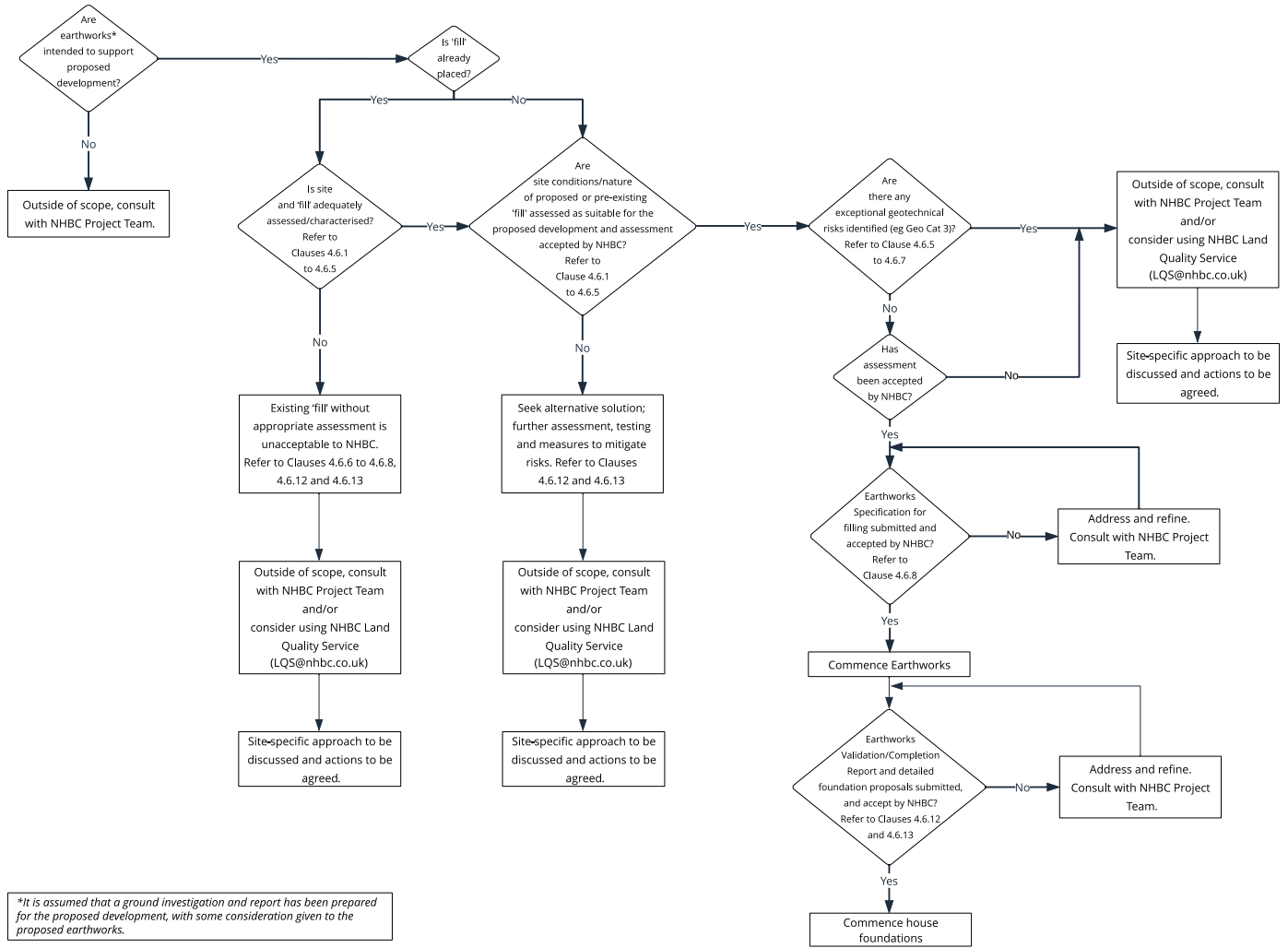

Definitions for this chapter

Acceptability testing	Geotechnical and chemical suitability testing of the source material(s) intended to be used as engineered fill.
Beam grillage	A reinforced concrete foundation designed to support load-bearing walls or structure, and to span a loss of support, and reinforced with traditionally cut and bent rebars and closed-loop links.
Buried batter	An inclined buried interface of natural soil and made ground, or between made ground and engineered fill, and potentially liable to cause differential settlement at the ground surface.
Cohesive fill	Containing clay of natural origin, comprising greater than 15% fines passing a 0.063mm sieve. Suitable for use as engineered fill but requires greater moisture control than granular material. Behaves in a plastic manner and can be deformed and remoulded by hand. Suitability is typically dependent on moisture content. Only clays with a plasticity index of less than 40% are acceptable as fill, where they are required to support building foundations. This includes Class 2 (general fill) and Class 7 (selected fill) in accordance with the name specified in Table 1 highway works: Series 600 — Earthworks.
Compliance testing	Geotechnical suitability testing of the engineered fill as it is being placed in layers on site
Differential settlement	Settlement of one part of a building or structure relative to another. While the total settlement of a structure may interfere with functions such as service connections, it is the differential settlement that causes structural damage.
Earthworks	Permanent change in ground profile and/or level, which may be due to the placement of fill to raise ground levels (filling) or the removal of material (cutting).
Earthworks specification	An earthworks specification describes the design requirements of proposed earthworks and includes how the earthworks should be undertaken and what acceptance criteria should be used to demonstrate their suitability.
End-use	The nature of the proposed final development located over the fill, including the buildings and their foundations, external works and infrastructure features, and associated activities in their normal use.
Engineered fill (also referred to as 'fill')	Fill that is selected, placed and compacted to an appropriate specification so that it will exhibit the required engineering behaviour to support structural loadings for buildings, external works (drives, paths and external walls) and infrastructure (roads, drains and services) without excessive settlement or risk of shear failure. Selected (structural) fill and general fill are examples of engineered fill.
Formation level	The prepared surface on which the engineered fill or the superstructure is built.
General fill	Suitable for the support of access roads, drainage, driveways and services buried within it or supported on it. Elements supported on general fill are usually less sensitive to differential ground movements than shallow foundations for residential buildings. Some degree of variability can be accepted in the completed fill, and fewer tests may be acceptable than for structural fill; however, it will still require a suitable regime of compliance and verification testing.
Geotechnical Design Report	A report that is used to develop a suitable and functional earthworks design for a proposed end use, which includes the full details on the interpretation of design data and justification for the design, including relevant layout drawings. They are produced for Geo Category 2 and 3 projects where engineered fill is being used to support building foundations.
Geotechnical Design Statement	A brief and abridged version of a Geotechnical Design Report for Geo Category 1 projects where engineered fill is not being used to support building foundations.
Granular fill	Free draining material predominantly comprising sands and/or gravels Good for use as engineered fill Having less than 15% fines (less than 0.063mm sieve size) Behaves in a non-plastic manner This includes Class 1 (general fill) and Class 6 (selected fill) in accordance with the Refer to title in Table 1 Specifications for highway works: Series 600 — Earthworks.
Ground improvement	Techniques used to stabilise or improve the strength of soils in situ. This includes dynamic compaction, rapid or high-energy impact compaction, surcharging and installation of vertical drains or vibro stone columns. These techniques may be applied to historic uncontrolled fill, loose native soils upon which engineered fills are to be placed or following placement of fill.
Highwall	The steep edge of quarry or opencast workings. Where the quarry is backfilled, it usually forms a zone of contrasting material behaviour where ground movements could be excessive and affected by significant differential settlement.
Historic fill	Comprises made ground and is not suitable for supporting building foundations, access roads, drainage, driveways and buried services without full investigation and assessment which should be provided in a ground investigation report.
Immediate settlement	Settlement which takes place during the application of a load as a result of elastic deformation without change in the water content.

Inundation settlement/ collapse compression	Occurs in poorly compacted made ground or fill placed dry of optimum moisture content and with high air voids. The failure mechanism is typically attributed to the subsequent rising of groundwater or surface water percolation, where the voids are filled with water and cause delamination. Burst pipes and leaking drains present a risk. It can occur in both cohesive and granular soils, with greater risk in cohesive soils.
Landscape fill	Unsuitable to support shallow foundations for buildings, ground floor slabs for buildings, other critical elements sensitive to differential ground movements, or any external works such as pavements, services or garden walls. Loading may be limited to construction equipment. There may be no geotechnical testing requirements for landscape fill other than for workability reasons. Landscape fill may be specified for garden areas alongside earthwork slopes and bunds in some developments.
Made ground	Material that has been placed but to an unknown or unrecorded filling specification. Its geotechnical and geo-environmental properties need to be established by appropriate ground investigation and testing for it to be reclassified and its suitability for reuse established.
Material classification	Assignment of materials into groups and classes for earthwork purposes. The groups and classes are established by testing the geotechnical properties of a material to determine its suitability for use as fill. The properties may include moisture content, grading, plasticity, compaction and recompacted CBR and shear strength, etc. Testing continues during earthworks placement to ensure material properties remain consistent and within defined limits to achieve the required compaction or fill performance.
Performance testing	Load-settlement testing of the completed engineered fill at its surface and ahead of building foundations.
Primary settlement or consolidation	Occurs after immediate settlement of material on loading. It occurs as pore water pressures dissipate and usually comprises the most significant element of the total settlement of a cohesive fill. Completion of primary settlement is most easily identified by graphical analysis of settlement data showing a 'levelling off' behaviour as secondary settlement then commences.
Raft foundation (semi-rigid raft)	A foundation consisting of continuous slab elements and down stand beams designed in accordance with Chapter 4.4 Raft, pile, pier and beam foundations to spread superstructure loads over the building footprint and provide a capacity to span a defined loss of support.
Reinforced strip	A reinforced concrete foundation designed to support load-bearing walls or structure, and to span a loss of support, and typically reinforced with two layers of mesh reinforcement.
Secondary settlement or consolidation	Occurs after primary settlement (ie, creep) and may continue for many years, including during the life of the development, depending on the soil types.
Selected and structural fill	Suitable for the support of shallow foundations for buildings and other critical elements sensitive to differential ground movements, or as backfill underneath ground-bearing slabs against earth-retaining structures. The completed fill is required to have a high degree of uniformity, high stiffness and low settlement potential, and requires a high degree of supervision and control and a high frequency of selection classification, compliance and verification testing.
Self-weight settlement	Settlement induced in a fill due to its own mass. The magnitude of self-weight settlement is a function of both the stiffness of the fill and its overall thickness. The contribution of self-weight settlement can be significant in cohesive soils.
Soil modification	Mechanical and/or chemical treatment of soils to create a suitable moisture content of an engineered fill to achieve the specified requirements of minimum relative compaction and maximum air voids. Processes include (non-exhaustively) destoning, formation of windrows with mechanical mixing or turning to promote air drying, addition of low-dosage (no greater than 2% by dry weight) binders such as lime and/or cement in order to moisture condition, lower plasticity and/or control silt fraction to promote optimal compactability.
Soil stabilisation	Mechanical and/or chemical treatment of soils to create substantial gain in strength to produce structural soil layers contributing significantly towards the performance or stability of earthworks. This would include (non-exhaustively) soil mixing with high dosage chemical admixtures or grouts, hydraulically bound materials and reinforced soils overlying weaker strata. It is currently outside the scope of this chapter and not accepted for the support of foundations.
Specification for earthworks	Acceptable methods by which satisfactory compaction of fill materials can be achieved. The three main types of specification for earthworks used in the UK are Method, End Product and Performance.
Total settlement	The combined magnitude of immediate, primary and secondary settlements.

4.6.1 Compliance

Also see: Chapter 2.1

Engineered fill shall comply with the Technical Requirements and provide adequate support for the proposed end-use. A suitably qualified and experienced engineer shall be responsible for the design, specification, supervision and validation reporting to be submitted to NHBC for assessment.

Engineered fill placed to a suitable earthworks specification that complies with the guidance in this chapter will generally be acceptable to NHBC. Reference shall also be made to Chapter 4.1 Land quality — managing ground conditions, for both geotechnical and contamination risks.

This chapter gives guidance for a wide range of circumstances where engineered fill is required. It is not the intention to describe all combinations of site conditions, end-uses, fill material types and filling techniques. Where conditions fall outside those described and detailed within this chapter, it is recommended that early engagement with NHBC should be undertaken prior to preparation of the earthworks specification.

The earthworks specification should be produced by a suitably qualified and experienced person acceptable to NHBC. Where engineered fill is to support building foundations, the earthworks specification should be produced by a suitably qualified engineer — refer to Technical Requirement R5 for detail on requirements.

Where engineered fill is being used to support building foundations, the earthworks specification should be supported by a geotechnical design report. A geotechnical design statement is acceptable where engineered fill is not being used to support building foundations.

British Standards, codes of practice and authoritative documents relevant to engineered fill, earthworks and structures formed upon engineered fill are detailed in Table 1.

Table 1: British Standards, relevant codes of practice and authoritative documents

Relevant standard	Additional guidance
BS EN 1997-1	Geotechnical design. General rules
BS EN 1997-2	Geotechnical design — Ground investigation and testing
BS 6031	Code of practice for earthworks
BS EN 16907	Earthworks. All parts
BS EN ISO 14688	Geotechnical investigation and testing. Identification and classification of soil. Parts 1 and 2
BS EN ISO 14689	Geotechnical investigation and testing. Identification, description and classification of rock
BS EN ISO 17892	Geotechnical investigation and testing. Laboratory testing of soil
BS EN ISO 22476	Geotechnical investigation and testing. Field testing. All parts
BS 1377	Methods of test for soils for civil engineering purposes. All parts
BS 10175	Investigation of potentially contaminated sites. Code of practice
BRE FB 75	Building on fill: geotechnical aspects
BRE IP 5/97	Building on fill: collapse compression on inundation
BRE Digest 427	Low-rise buildings on fill. All parts
BRE Digest 433	Recycled aggregates
BRE SD1	Concrete in aggressive ground
ICE	Earthworks: a guide (by Paul Nowak and Peter Gilbert)
MCHW ¹ Volume 1	Specification for highway works: Series 600 - Earthworks (SHW)
DMRB ² Revision 1 CD 622	Managing geotechnical risk
CIRIA C574	Engineering in chalk
CIRIA C504	Engineering in glacial tills
CIRIA C570	Engineering in Mercia mudstone

Notes

1. Manual of Contract Documents for Highway Works.
2. Design Manual for Roads and Bridges.

4.6.2 Provision of information

Earthworks design and specifications shall be produced in a clearly understandable format, including all relevant information, and shall be distributed to all appropriate parties.

The earthworks specification and accompanying information, including relevant drawings, should be submitted to NHBC at least eight weeks prior to the commencement of filling or associated works. The earthworks specification should also be issued to site supervisors, the earthworks contractor and relevant specialist subcontractors (see Clause 4.6.7 for details of what should be included within an earthworks specification).

An earthworks method statement, from the earthworks contractor or equivalent, should be produced and issued to all relevant personnel. It describes how the requirements of the specification are to be delivered, the plant to be used and arrangements for supervision and reporting.

In addition, the following supporting information should be provided to NHBC:

- desk study and ground investigation report
- geotechnical design report or geotechnical design statement (depending on which is relevant)
- materials classification (acceptability) assessment
- earthworks verification report.

This list is not exhaustive, and additional content may be required depending on site-specific circumstances.

4.6.3 Hazardous sites and ground hazards

Also see: Chapters 2.1, 4.1 and 4.2

Placement of engineered fill on hazardous sites shall be reported to NHBC before work on site commences and shall be specified to take account of any ground hazards.

Hazardous sites, as defined in the NHBC Rules, should be reported to NHBC in writing at least eight weeks before earthworks begin.

Details of ground hazards to be taken into consideration are given in Chapter 4.1 Land quality — managing ground conditions and Chapter 4.2 Building near trees.

4.6.4 Desk study and ground investigation

Also see: Chapters 2.1, 4.1 and 4.2

A desk study and ground investigation shall be undertaken, and the findings used to inform the design of the filling and earthworks specification.

A desk study and sufficient ground investigations should have been undertaken to characterise the site and identify all the features and potential geotechnical and environmental ground hazards relevant to the earthworks, including classification of the fill material itself.

The ground investigation should take account of the findings of the desk study and relevant standards listed in Clause 4.6.1. Further guidance is given within Chapter 4.1 Land quality — managing ground conditions.

The desk study and ground investigation should determine the items listed in Table 2, as a minimum.

Table 2: Typical items to be covered by desk study and ground investigation

Item to be determined	Guidance
Site history and past usage (eg agricultural, residential, commercial or industrial)	To aid in determining a ground model for the site and potential areas of concern
Known areas of made ground	As shown on BGS GeoIndex, other geodata services, historical site investigations and their reports
The nature of the underlying geology	To determine the potential for soft, loose soils, instability, voids or highly compressible soils, and to allow an assessment of pre- or post-treatment of the existing ground
The proximity of any existing buildings, roads or services	To assess whether these could be affected by ground movement caused by filling
The strength/density, compressibility and stability of soils beneath the proposed fill and for the potential reuse as fill earthworks	To enable the level of risk to be determined, including settlement of the underlying soils and whether unsuitable material needs to be removed or if any form of pre-treatment is required. To assess the acceptability of site derived fills
The nature (presence and extent) of any groundwater and surface watercourses	To assess whether groundwater (or surface water) may affect the existing made ground/ natural soils or newly placed fill — for example by causing inundation settlement or washout of ‘fines’
The geotechnical properties of soils, including sulfate content and pH	To determine the suitability of soils for use as engineered fill and for the design of buried concrete
The presence of any slopes, embankments, cuttings, quarry highwalls, buried batters or earth faces	To assess the potential negative effect of earthworks on existing ground stability and the potential effect of features on the performance of earthworks and foundations bearing upon the placed fill
The presence of any buried services, culverts, tunnels or other buried structures	To assess the effect of structural loading from placed earthworks and associated earthworks machinery, and whether protection or mitigation measures are required. To allow an assessment for potential effect of structural ‘hardspots’ on building foundations
The presence of contaminated substances or materials suspected to be contaminated	To assess whether cut earthworks and placement of filling may cause, or increase, the release of contaminants such as leachate, hazardous ground gases, etc (refer to Chapter 4.1 Land quality — managing ground conditions)
Geotechnical risks	An initial geotechnical risk register to ensure that all known or anticipated natural or man-made geohazards are identified and can be investigated and considered within evolving stages of investigation, design and earthworks placement

Other items to consider in addition to Table 2, but not repeated here, are listed in Table 1 of Chapter 4.5 Vibratory ground improvement techniques and in Chapter 4.2 Building near trees.

Where a ground investigation has been undertaken without considering the proposed earthworks, it may be necessary to carry out further supplementary investigation, sampling, testing and/or monitoring to inform the earthworks design and earthworks specification.

4.6.5 Suitability of ground conditions

Also see: Chapters 2.1, 4.1 and 4.5

The ground to be filled over shall be suitably stable and appropriate for the proposed earthworks and end-use. Issues to be taken into account include:

- | | |
|---------------------------------|----------------------------|
| 1) unsuitable ground conditions | 4) unstable ground |
| 2) obstructions | 5) groundwater conditions. |
| 3) compressible soils | |

The geotechnical design should be prepared by a suitably qualified and experienced engineer who should assess the ground and be satisfied that it is suitable for engineered fill. Prior to earthworks commencing, the formation level should be inspected and tested in accordance with the earthworks specification.

Engineered fill may be placed on natural ground or made ground — both need to have been appropriately investigated to assess their suitability to provide long-term support to the engineered fill and proposed end-use. Where engineered fill is to be placed on made ground, the made ground will be considered as a residual geotechnical risk for the purposes of geotechnical design.

It may be acceptable to partially excavate existing ground and recompact it in place in order to provide a stiffened layer with improved bearing capacity, settlement characteristics and reduced permeability (as required). Settlement of both the engineered fill layer and the ground beneath should be assessed.

4.6.5.1 Unsuitable ground conditions

Prior to the execution of earthworks filling, unsuitable materials should be removed from the formation level, including:

- topsoil, tree roots, highly organic matters or other degradable materials
- frozen soils
- excessively wet or soft soils, such as silty soils or clays, with an undrained shear strength of less than 40kPa, where untreated to adjust their soil properties
- contaminated soils, and soils containing slag or combustible materials.

Unsuitable materials may be treated, in some circumstances, to adjust and improve the soil properties. Further assessment would be required to determine their suitability after treatment and prior to any subsequent placement as engineered fill.

4.6.5.2 Obstructions

Obstructions, including oversized materials or relic foundations that may impede future works in the ground or adversely affect earthworks filling or drainage should be removed.

It may be impractical to remove some obstructions beneath engineered fill, such as former piles, etc. These should be adequately surveyed and their locations accurately recorded. Any retained relic structure or obstructions should be a minimum of 2m beneath the underside of proposed building foundations. Future building foundations should be assessed for potential effect of structural 'hardspots'.

4.6.5.3 Compressible soils

Where compressible soils are present, such as soft clays, disturbed ground or peat, the effects of earthworks should be assessed, including the magnitude and duration of induced settlements.

Where significant settlements of the underlying soils are predicted, it may be necessary to remove and undertake additional earthworks or alternative ground improvement works, such as the installation of vertical drainage, or surcharging prior to filling of earthworks.

The effects of 'drying out' compressible soils, such as peat beneath engineered fill, should be assessed where earthworks may reduce water infiltration, or the development may cause lowering of groundwater levels.

4.6.5.4 Unstable ground

Voids that might collapse or cause excessive settlement (ie, dissolution features, mine workings and entries, sewers and drains) should be adequately investigated and suitably infilled or grouted prior to the commencement of any earthworks filling or building foundations.

Unstable natural deposits or materials susceptible to solifluction (materials that have undergone progressive, gravitation and downslope movement) should be adequately investigated and addressed by the geotechnical design.

4.6.5.5 Groundwater conditions

The following conditions may adversely affect the long-term performance of engineered fill, if not properly considered and allowed for within the design and specification:

- lowering of the water table to facilitate filling may cause settlement of existing adjacent buildings
- rising or recovery of groundwater levels after filling may cause inundation settlement of fill or wash-out of 'fines' and settlement
- falling groundwater levels could cause settlement of soft strata, including peat
- lack of surface water management (ie, non-provision of adequate capping and drainage) following earthworks to ensure no subsequent deterioration over time.

4.6.6 Materials for use as engineered fill

Also see: BRE SD 1-Part 1, BRE Digest 433, BS EN 771 and ICE's Earthworks: a guide

Engineered fill materials shall be suitable for the site conditions, proposed end-use, and techniques for placement and compaction. Issues to be taken into account include:

- 1) suitable sources of engineered fill materials
- 2) treatment of fill materials.

The earthworks specification should indicate the materials to be used for filling, including their geotechnical classification and range of properties that should be subject to monitoring and testing. Material classification should be clearly stated for example, Class 1C Coarse Granular General fill or a Class 6N Well Graded Selected Granular fill in accordance with Specification for highway works.

Materials that do not fully comply with the earthworks specification must not be used as engineered fill.

4.6.6.1 Suitable sources for engineered fill materials

Engineered fill material may be site-won or imported from appropriate suppliers or donor sites. Where differing engineered fill types are placed in subsequent layers or distinct zones, it is important to ensure compatibility — for example, to ensure that fines are not washed out of one material into a more coarsely graded material, geotextile separators may be required.

Where material is obtained from stockpiles, the homogeneity should be confirmed. Different forms of stockpiling can affect particle size and grading. The outside of a stockpile may be weathered and may not be the same as the unweathered material within. The use of recycled aggregate as fill should comply with BRE Digest 433 or other suitable guidance as agreed with NHBC.

Details of considerations regarding the acceptability of materials for reuse as engineered fill are provided in Table 3. Tests undertaken to confirm acceptability should be carried out by a UKAS and/or MCERT accredited laboratory (or other specialist laboratories) in accordance with the earthworks specification, appropriate standards and industry guidance, with a detailed knowledge of the materials to be tested and proposed end use. The samples which are tested must be representative of the true nature of the material.

Table 3: Acceptability of materials for reuse as engineered fill

Material description	Examples of material	Details on acceptability for reuse as fill
Suitable sources for fill materials	<ul style="list-style-type: none"> natural sands and gravels clays with a plasticity index of less than 40% and undrained shear strength in excess of 40kPa chalk (structured chalk of grades C5 to A1 only) crushed rock crushed concrete, brick or stone 	Typically, the material would be acceptable to NHBC for engineered fill, provided that it complies with appropriate classification criteria. For material that is solely crushed brick, further assessment of strength will be required to ensure its durability.
Hazardous materials	<ul style="list-style-type: none"> reactive materials materials that include sulphides or sulfates, eg gypsum organic materials materials that cause noxious fumes, rot, undue settlement or damage to surrounding materials 	Appropriate testing required to demonstrate their suitability.
Fill material requiring NHBC acceptance	<ul style="list-style-type: none"> unburnt colliery spoil or shale (carbonaceous mudstone) with excessive coal or pyrite content colliery shale (ie, burnt shale or red blaze) steel slags furnace ashes and other products of combustion material obtained from demolition without screening, crushing and processing soils with a silt content greater than 20% and where it will alter the behaviour of the overall engineered fill highly variable materials on wet sites, or sites with a high-water table, crushed or broken bricks which have no limit on their soluble salt content (as defined in BS EN 771) high plasticity site won clays with a plasticity index of greater than 40%. 	Not to be used as engineered fill unless a written agreement has been obtained from NHBC (appropriate testing and supporting technical report to be provided to demonstrate their suitability).
Unsuitable fill materials	<ul style="list-style-type: none"> soils containing topsoil or significant organic matter (such as leaves or wood) greater than 6% by volume degradable, reactive or non-durable materials expansive materials, (ie, steel slag and gypsum containing materials) where testing has not determined their risk materials capable of releasing contaminants or hazardous gases combustible materials (ie, materials with a high calorific value greater than 7MJ/kg) placed within the top 1m of the finished development platform materials containing significant amounts of plaster, plastic or rubber over 2% by weight materials containing harmful substances which pose a risk to human health and the environment structureless chalk (with grades Dm and Dc) materials that are not generally used as engineered fill on residential sites 	Fill containing these constituents are NOT acceptable for use.

4.6.6.2 Treatment of fill materials

The following techniques may be used to modify the moisture content of materials to render them suitable for use as engineered fill:

- placement in windrows or layers with mechanical turning as required for drying purposes
- the addition of lime and/or cement, typically up to 2% by weight to reduce the moisture content to nearer the optimum moisture content (OMC) for maximum dry density
- the addition of water by spraying or similar to increase the moisture content to nearer the OMC for maximum dry density.

The following techniques are not acceptable to NHBC for the treatment of materials for use as engineered fill:

- stabilisation to improve strength by the addition of over 2% lime and/or the addition of any cement or other hydraulic materials
- the addition of chemical binders or grouts.

4.6.7 Design and specification of earthworks

Also see: BS EN 1997-1, BS EN 16907-1, BS 6031

A suitably qualified engineer shall be responsible for the design and specification of earthworks, taking into account future development and type of building foundations. Engineered fill shall be placed in accordance with a suitable earthworks specification. Issues to be taken into account include:

- 1) geotechnical design
- 2) earthworks specification
- 3) types of specification.

Engineered fill should be placed to a suitable earthworks specification — the scope, details and requirements of the specification should be appropriate to the site, the nature of the fill, the techniques of placement and the end-use of the site.

4.6.7.1 Geotechnical design

On engineered fill sites, an element of geotechnical design will be required by NHBC. The complexity of the design and its supporting earthworks specification should reflect the scope of works and the associated risk. Geotechnical design is covered in BS EN 1997 Geotechnical design, with earthworks specifically covered by the requirements set out in BS 6031 (Code of practice for earthworks) and BS EN 16907 Earthworks.

It is recognised that on certain residential developments, the level of earthworks required can be minimal, with a low to negligible risk associated with the project. Where the scope of the earthworks is defined as Geotechnical Category 1 (Geo Cat 1), based on Table 4, a Geotechnical design statement (GDS) shall be prepared and submitted to NHBC.

Most earthworks are classified as Geotechnical Category 2 (Geo Cat 2) in accordance with BS EN 1997-1 and are required to be designed by an appropriately qualified and experienced person. Where the scope of the earthworks is defined as Geo Cat 2 or 3, a Geotechnical design report (GDR) shall be prepared and submitted to NHBC.

The content lists of a GDS or GDR may be prepared using outline from Managing Geotechnical Risks DMRB CD 622, as a guide. Both the GDS and GDR should be prepared by a suitably qualified engineer.

Table 4 should be used to attribute a geotechnical category to projects, and the subsequent requirements for GDS or GDR.

Table 4: Geotechnical design categories

Assessment of the site and proposals		
Geohazards — legacy of mining/quarrying, un-engineered fill, low strength/bearing capacity, slope stability, etc		
Preparatory works — removal of remnant foundations, obstructions, settlement monitoring, mining treatment, etc		
Requirement for ground improvement — preloading, surcharging, dynamic compaction, etc		
Category	Scale and extent of earthworks and end-use	Required information
Geo Cat 1 SIMPLE	<p>Considered to have negligible geotechnical risk and may be designed adopting a qualifiable approach. The Geotechnical design statement (GDS) and earthworks specification should clearly define the scope of works covered by the Geo Cat 1 design and can be presented on drawings, accompanied by appropriate risk assessment.</p> <p>Typical sites would include:</p> <ul style="list-style-type: none"> • greenfield sites • no geotechnical hazards • suitable existing ground conditions, no or minimal preparatory works and ground improvement measures • placement of engineered fill limited to proposed infrastructure, external works and earthworks slopes no steeper than 1V:5H • use of general fill only. 	<p>A GDS</p> <p>Summary based on good local experience and ground conditions that are well known and uncomplicated</p>
Geo Cat 2 CONVENTIONAL	<p>Considered to have no exceptional geotechnical risk associated with them, either during or post-construction. The records of the quantifiable design shall be presented in the Geotechnical design report (GDR), which should be accompanied by the earthworks specification.</p> <p>Typical sites would include:</p> <ul style="list-style-type: none"> • brownfield sites • some or many geotechnical hazards to be removed or suitably mitigated • some or many preparatory works to be undertaken, the requirement for one or more ground improvement measures • placement of engineered fill limited to proposed infrastructure, external works and earthworks slopes steeper than 1V:5H • placement of engineered fill supporting building foundations and settlement sensitive elements • use of selected fill and general fill. 	<p>A GDR</p> <p>Based on the current BS EN 1997-1</p>
Geo Cat 3 COMPLEX	<p>Considered to have exceptional geotechnical risk with unstable ground conditions. Geo Cat 3 designs require an independent third-party check and are not covered by the requirements of this chapter.</p> <p>Typical characteristics include:</p> <ul style="list-style-type: none"> • mostly brownfield sites • many geotechnical hazards to be removed or suitability mitigated • requiring a wide range of preparatory works to be undertaken • exceptionally difficult ground conditions with ongoing instability, ground movements or requiring investigation and special measures • placement of engineered fill supporting very large or unusual structures/buildings. 	<p>A GDR</p> <p>Typically, outside the scope of this standard</p> <p>Consultation with the NHBC and/or the Land Quality Service</p> <p>lqs@nhbc.co.uk</p>

4.6.7.2 Earthworks specification

The earthworks specification should be prepared once the earthworks design has been undertaken and the properties of the proposed fill material have been established. It should clearly describe the design requirements to be satisfied ie, detail how the engineered fill is to be placed and what criteria will apply to prove its compliance, and include the information detailed below. An earthworks specification should be practicable and capable of both measurement and enforcement, and should be capable of being monitored by an effective form of quality assurance procedure.

A typical earthworks specification should include the following:

1. Description of scope and aims of the earthworks including reference and brief summaries of supporting documents:
 - a. Desk study and ground investigation report
 - b. Geotechnical Design Report (GDR) or Geotechnical Design Statement (GDS)
 - c. Materials classification (acceptability) assessment
2. The intended end-use of the engineered fill should be defined
3. Details of any site preparation works required prior to earthworks filling and the treatment of exposed surfaces to prevent deterioration
4. Types of materials permitted for use together with material properties, including arrangements to prevent the deterioration of cohesive materials
5. Classification testing may include particle size distribution, plasticity (Atterberg Limits), compaction tests or moisture content tests should be undertaken to confirm that the fill materials remain within the earthworks specification
6. Types and frequency of classification tests should be site and material specific and confirmed in the specification. Acceptable test methods and frequencies of classification tests given in Tables 9 and 10 of BS 6031: 2009
7. Requirements for the placement, spreading and compaction of earthwork materials, including compliance criteria
8. Requirements for the disposal of unsuitable material
9. Testing proposals for the verification of compliance criteria and performance requirements to be met for end product and performance specifications, including load-settlement testing
10. Arrangements for supervision
11. Proposed as-built records to reflect the completed works
12. Construction drawings showing the proposed extent of the filling works (including thickness)
13. All other site-specific requirements and relevant construction drawings showing retained features, constraints, etc
14. The form and proposed content of an earthworks validation report

4.6.7.3 Types of specification

Three types of standard Specifications for Earthworks are acceptable to NHBC:

- method
- end product
- performance.

Method specification defines how compaction should be conducted in terms of the types of compaction plant, method of operation, number of passes of the plant and the final thickness of the compacted layer.

The end product specification defines the degree of compaction necessary and, if appropriate, stiffness requirement for the given material by reference to criteria linked to either serviceability or ultimate limit states. The level of compaction required is normally expressed in terms of selected geotechnical properties eg percentage of maximum dry density or prescribed minimum stiffness and is supported by on-site earthworks testing. Where an end product specification is used, the requirements normally define overall targets to be achieved without detailing the methods to be used to achieve the targets.

Performance specifications require the works to be defined relative to long-term project requirements, which are commonly set at a relatively high level. For example, the criteria may be defined based on the long-term fitness for use of a building that is to be formed upon the completed earthwork. NHBC requires a performance specification to be used in combination with an end product specification.

NHBC specification requirements for use on residential development are summarised in Tables 5 and 6.

Table 5: Types of specification for earthworks acceptable to NHBC

Specification	Specification requirements
Method	<ul style="list-style-type: none"> the thickness of fill layers to be compacted type of compaction plant number of passes required compaction requirements (typically 90% maximum dry density and <10% air voids)
End product	<ul style="list-style-type: none"> the geotechnical properties to be achieved following placement of engineered fill — typically dry density, moisture content and air voids the criteria for acceptable compliance and compaction requirements (see Table 6) proposals in the event of non-compliance
Performance	<ul style="list-style-type: none"> Defined by relative long-term projects requirements eg engineered fill and the underlying ground supporting building foundations shall limit building settlements to less than 25mm and minimise angular distortion or tilt to 1:400 for 60-year design life NHBC requires a performance specification to be used in combination with an end product specification the behaviour the completed engineered fill is required to achieve under testing — usually limits of settlement under specified load and/or over time details of the performance testing to be undertaken, including testing frequency proposals in the event of non-compliance during placement and of performance testing

Table 6 provides the minimum level of compaction required throughout the placement of all engineered fill for both the support of building foundations and external and infrastructure works.

Table 6: End product acceptance criteria

End use	Acceptance criteria
Building foundations	>95% MDD* and <5% air voids (4.5kg or vibrating rammer) >98% MDD* and <5% air voids (2.5kg rammer)
External/infrastructure	>95% MDD and <5% air voids where fill >5m thick (2.5kg/4.5kg rammer)

*MDD = Maximum Dry Density

It may be appropriate for a project technical specification to incorporate different forms of earthworks specification for different types of fill material, eg method compaction for general fills and end product compaction for coarse granular fills.

The earthworks specification shall include relevant conditions to be satisfied during construction to ensure the following are met:

- materials are chemically suitable for the project and the surrounding environment
- materials should be durable, and not prone to deterioration or non-biodegradable
- earthworks should provide a stable finished surface that will limit post-construction settlement or movement within the engineered fill
- the earthworks should provide a surface of sufficient stiffness and/or shear strength for the intended use.

Once agreed with NHBC, the earthworks specification should not be amended on site without prior agreement with NHBC.

The earthworks specification should be based on industry guidance, such as the Specification for Highway Works, BS EN 16907 Earthworks, ICE Publishing — Earthworks: A Guide 2nd Edition, or on trials/previous experience, that is acceptable to NHBC.

The earthworks specification should outline if placing, testing and verification of earthworks fill is to be completed on the whole site, or undertaken and presented in a phased approach to facilitate the build programme.

Table 7 shows the types of earthworks specification that are acceptable to NHBC for different types of engineered fill and subsequent end-use, considering the starting ground (formation) level has been assessed as suitably stable and appropriate for the proposed earthworks and end-use (as per Clause 4.6.5).

Table 7: Matrix for determining appropriate types of earthworks specification

End-use	Support of foundations	Support of external works	
Depth of fill	N/A ⁽¹⁾	<5m	>5m
Granular and cohesive fill types (including mixed fills)	End product plus performance (reinforced strip and beam grillage)	Method	End product
	End product (semi-raft)		

Note

1. Acceptable minimum depth of engineered fill beneath building foundations = 600mm.

Figure 2 illustrates the guidelines for the use of differing earthwork specification for different end-use, located in close proximity.

Figure 2: Compaction and differing end use

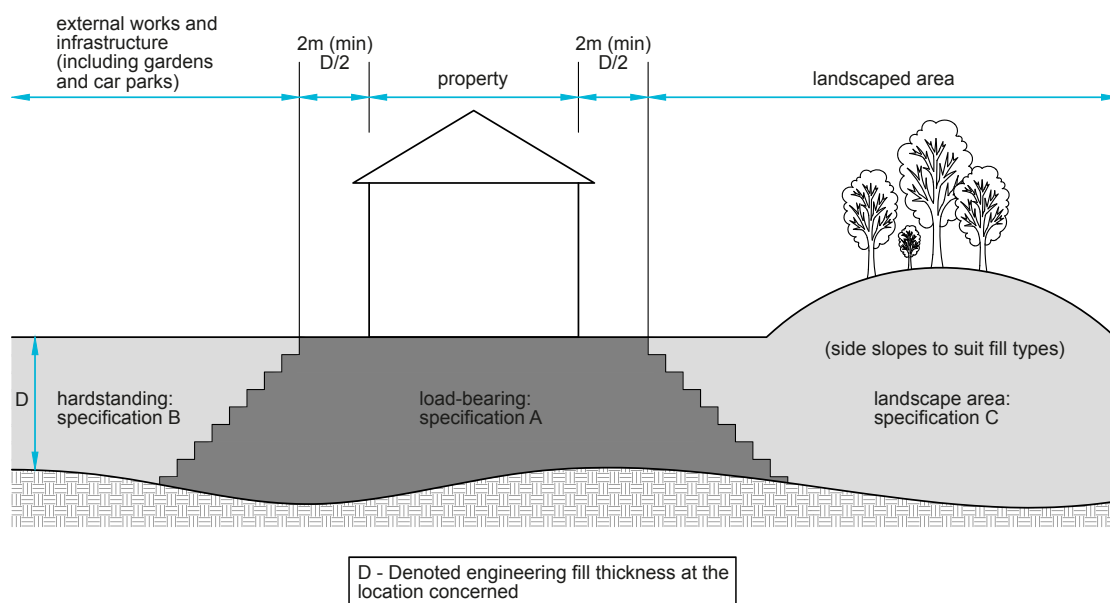

Notes:

1. Specifications A and B to be Table 3
2. Specifications C may be method or end product or no defined compaction regime

4.6.8 Compatibility of fill with foundations, infrastructure and external works

Placed engineered fill shall support foundations, infrastructure and external works as required without excessive settlement. Issues to be taken into account include:

- | | |
|---|--|
| 1) building and foundation types | 3) building settlements and relative movements |
| 2) engineered fill performance and foundation options | 4) external works and infrastructure. |

This section provides guidance on building foundations that will generally be acceptable to NHBC. Where more rigorous structural or geotechnical analysis is carried out, alternative solutions may be acceptable, but these must be agreed with NHBC in advance of development.

4.6.8.1 Building and foundation types

Engineered fill covered within this chapter should be capable of supporting foundation loads from buildings of three storeys or equivalent weight.

Where compliance testing of engineered fill demonstrates a high level of consistency and quality in combination with a high level of supervision and control, a suitably structurally designed reinforced strip foundation may be acceptable. This can only be so in conjunction with ground hazards and risks associated with excessive settlements being suitably addressed. A suitably structurally designed beam grillage will also be acceptable.

Where engineered fill has been placed to a suitable earthworks specification with a satisfactory verification testing, a semi-rigid raft foundation in accordance with Chapter 4.4 Raft, pile, pier and beam foundations will be acceptable to support buildings.

Reference should also be made to the requirements of Chapter 4.2 Building near trees and Chapter 4.3 Strip and trench fill foundations as appropriate. Cohesive fill material should be taken as having a similar volume change potential (and requirement for minimum foundation depths) as natural clays of the same plasticity index.

4.6.8.2 Engineered fill performance and foundation options

Residential developments founded on engineered fill are more sensitive than other structures or infrastructure founded on the same material, and require foundation solutions that will mitigate the potential for both aesthetic and structural damage over the design life of the building. Any foundation solution adopted should be sufficiently robust to accommodate the predicted future settlements and prevent damage to building superstructures. To provide the required stiffness, rigidity and robustness against unwanted movements, all foundations on engineered fills should be reinforced. Unreinforced strip foundations would not be acceptable to NHBC under any circumstances.

Table 8 indicates the minimum requirements necessary for a shallow foundation to be used on engineered fill and considers different foundation types that may be used based on the achieved compaction of the engineered fill only. The table should only be used where no other residual geotechnical risks are present, and assumes that the engineered fill is placed on competent natural ground.

The foundation specified should consider the holistic geotechnical design (eg bearing capacity and settlement) and also allow for any retained geotechnical risks outside or below the engineered fill. Table 8 should not be used to justify a less robust foundation where unresolved geotechnical risks remain.

Where the requirements of Table 8 have not been significantly achieved, for example poor execution or poor site supervision, or inadequate testing or reporting, or where the verification of the earthworks falls outside the minimum requirements given below, an alternative foundation solution outside this chapter will need to be considered — ie, solutions from Chapter 4.4 Raft, pile, pier and beam foundations or Chapter 4.5 Vibratory ground improvement techniques. Where piles are considered, the potential for negative skin friction on the piles due to creep settlement of the placed engineered fill and/or the consolidation of any underlying soils should be assessed.

Table 8: Engineered fill performance and acceptable foundation options

Proposed outcome	Reinforced strip	Beam grillage	Semi-raft
Minimum relative compaction (% maximum dry density) ⁽¹⁾	>95	Majority of results >95 However, results show some variability and non-compliances (see Figure 7) No results <90	Majority of results >95 However, results show some variability and non-compliances (see Figure 7) No results <90
Maximum air voids (%)	<5	Majority of results <5 However, results show some variability and non-compliances (see Figure 7) No results >10	Majority of results <5 However, results show some variability and non-compliances (see Figure 7) No results >10
Supervision	A very high degree of independent supervision Full-time independent resident geotechnical engineer dedicated to inspection, supervision and testing of the fill	A high degree of independent supervision Full-time inspection of the filling by an independent resident geotechnical engineer	Good/normal supervision Part-time inspection of the filling by an independent geotechnical engineer
Contractor	Experienced/specialist earthworks contractor	Experienced earthworks contractor	Suitably experienced groundworker or earthworks contractor
Engineered fill	Fill generally of consistent depth and properties throughout Fill behaviour should have been proven by precedent or trials	Fill generally of consistent or steadily varying depth Little variation in fill properties	Effects of variations in fill depth and properties should be assessed with predicted settlements established
Foundation performance testing	Zone load tests and/or mini zone load tests and plate load tests across fill depth and at surface ⁽²⁾	Mini zone load tests and plate load tests across fill depth and at surface ⁽²⁾	Plate load tests across fill depth and at surface ⁽²⁾
Verification	Earthworks verification report produced by a third-party organisation	Earthworks verification report produced by an experienced earthworks contractor	Earthworks verification report produced by an experienced earthworks contractor/groundworker
Foundation design	Design by a suitably qualified engineer to relevant British Standards Designed for moment to span 2m as simply supported and 1.0m as a cantilever ⁽³⁾	Design by a suitably qualified engineer to relevant British Standards Designed to span 3m as simply supported and 1.5m as a cantilever	Design by a suitably qualified engineer to Chapter 4.4 Raft, pile, pier and beam foundations

Notes

1. Modified Proctor hammer (4.5kg).
2. Minimum 600mm diameter.
3. Foundations to be typically reinforced with mesh reinforcement at top and bottom.

In circumstances where there is a potential increased or significant geotechnical residual risk of long-term creep settlements, for example as a result of the type or thickness of placed engineered fill or underlying thickness of made ground beneath the engineered fill, a stiff reinforced concrete raft or stiff beam grillage foundation may be required.

4.6.8.3 Building settlement and relative movements

The total settlement between any part of the building foundation and the surrounding ground or external area should not normally exceed 25mm over the 60-year design life.

Where engineered fill or the underlying ground is undergoing steady uniform settlement, a total foundation settlement of over 25mm may be acceptable, provided the differential settlement is compliant with the guidance below and the foundation solution is sufficiently robust.

The tilt or distortion (differential settlement) of any part of the foundation should not exceed 1 in 400. The potential differential settlement of any foundation should be assessed where:

- the depth of fill significantly varies
- there is a tapered layer of compressible material
- a quarry highwall or buried batter is present.

Where predicted total or differential settlements of any part of the building foundation exceed the above criteria, further assessment will be required to determine suitable alternative foundation solutions. The presence of highwalls in particular will require rigorous assessment, including their location, geometry and observed load-settlement behaviour of the engineered fill following remediation, if they are to be considered by NHBC to be suitable to build residential development upon.

The effects of differential settlement between external areas and buildings should be assessed; in particular, where they are piled or supported on vibro columns. Additional means of support or measures to mitigate ground movement may be required where excessive settlements could be realised ie, the use of flexible drainage and/or surcharging.

Figures 3 and 4 show examples of engineered fill over rolling landscape and over buried features where part removal of the feature was necessary to mitigate excessive tilts.

Figure 3: Engineered fill over gentle rolling landscape

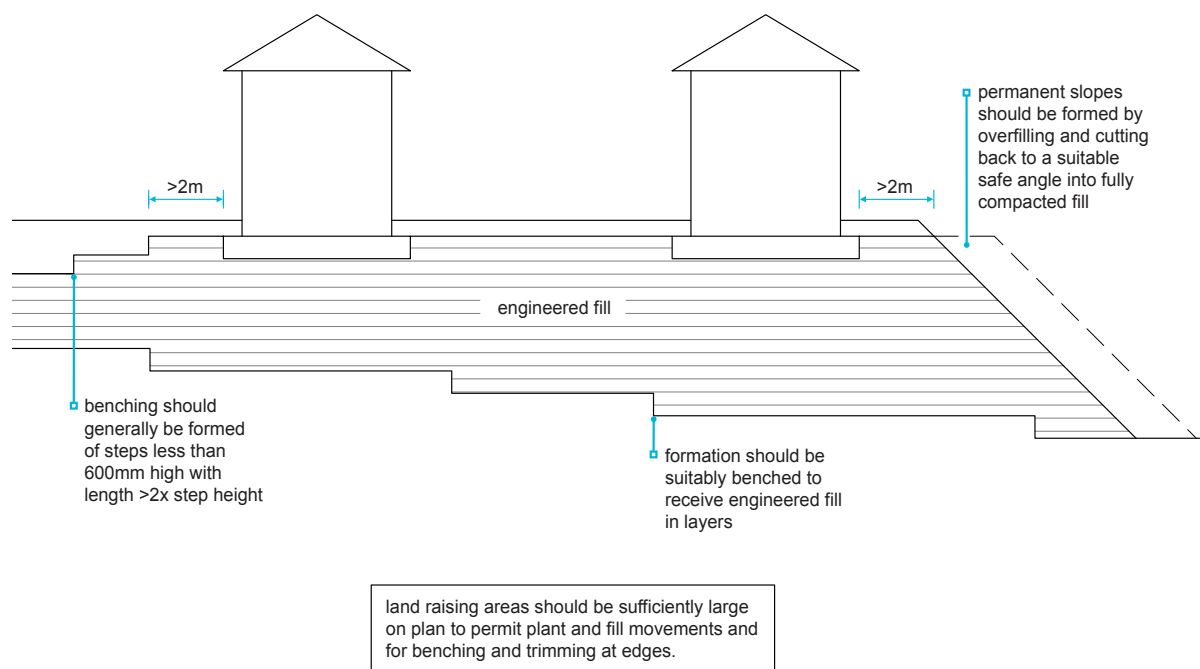
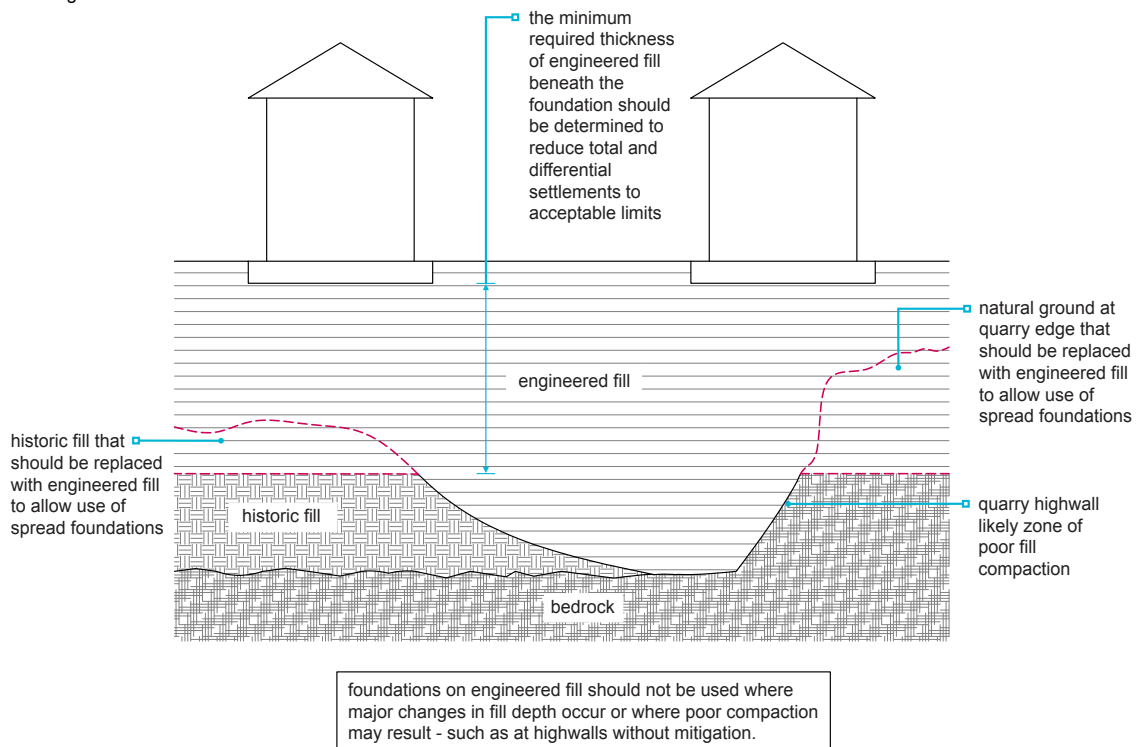

Figure 4: Engineered fill over buried features



4.6.8.4 External works and infrastructure

It will generally be acceptable to support low height retaining walls and boundary walls on mass concrete or reinforced foundations placed on engineered fill. Walls should be provided with joints and/or reinforcement as considered appropriate to provide flexibility and structural integrity while accommodating ground movements, particularly at locations where depths of engineered fill and settlements may vary. Geotechnical and structural designs are required where retaining walls are in excess of 0.6m in height.

Wall foundations, hardstandings and roads should be designed according to appropriate guidance and achieved geotechnical properties of the engineered fill.

Where external works and infrastructure pass from engineered fill to the natural ground, or where the depth of engineered fill varies significantly, the potential for differential ground movements should be assessed and catered for. Additional measures should be provided as necessary, eg the use of geogrid or futureproofing drains by potentially laying to steeper falls and the use of flexible jointing.

For areas not within the influence of building foundations (ie, hardstanding, gardens, infrastructure or external works areas), a maximum total long-term settlement of over 25mm would generally be acceptable subject to serviceability design limits (see Figure 2 for an approximate delineation of these areas).

4.6.9 Acceptable methods of earthworks filling

Also see: SHW Series 600

Earthworks filling shall only be undertaken using methods acceptable to NHBC that are appropriate to the materials, site conditions and end-use. Issues to be taken into account include:

- 1) conventional compaction
- 2) non-standard compaction
- 3) preloading and surcharging.

4.6.9.1 Conventional compaction

Placement and compaction of engineered fill should be undertaken in layers of controlled depth using appropriate plant. Acceptable methods are considered to be those based on the recommendations from the Specification for highway works (SHW) Table 6/4.

The type and size of the compaction plant should be based on the volume or depth of engineered fill to be placed, the classification of the fill to be compacted, and the specification requirements.

4.6.9.2 Non-standard compaction

This aspect covers all methods of compaction which are not covered by SHW Table 6/4. Details of non-standard plant and techniques should be submitted to NHBC in writing at least eight weeks before site works begin. Non-standard techniques include, but are not limited to:

- rapid impact compaction (RIC), using a rammer
- high energy impact compaction (HEIC), using polygon or triangular rollers
- dynamic compaction, using heavy drop weights dropped from a crane.

NHBC will require evidence of the effectiveness of non-standard plant or techniques, or demonstration of the suitability of proposals for the site conditions by trials as appropriate, particularly for large or complex projects. Site trials, including testing requirements, should be designed and agreed with NHBC prior to commencement. Trials must accurately reflect the proposed filling techniques and achieve specified performance requirements, and may require post-treatment investigation and load testing.

4.6.9.3 Preloading / surcharging

Placement of a surcharge may be an acceptable form of ground improvement but should not be used in place of the compaction techniques described previously. The design of the surcharge, including its magnitude and duration of surcharge requires careful analysis.

The effectiveness of surcharging should be demonstrated by monitoring or by trials. The requirements for monitoring and supervision are outlined in BS EN 1997-1 and BS 6031 and should be presented in the GDR. The surcharge load should be maintained until the achievement of the design requirements has been demonstrated. Refer to BRE FB 75 for further guidance.

4.6.10 Site work

Also see: BS EN 16907-5 and BS 6031

The developer or builder shall ensure suitable supervision, sampling and testing are performed throughout the entire duration of the earthworks. Filling shall be undertaken by a competent contractor using materials, personnel and plant appropriate for the nature of the site conditions and proposed end-use. Issues to be taken into account include:

- | | |
|----------------------------|--|
| 1) supervision and records | 4) material acceptability and compliance testing |
| 2) site preparation | 5) actions in respect of non-compliant fill |
| 3) material handling | 6) protection of fill. |

4.6.10.1 Supervision and records

The developer or builder must arrange for a suitable site supervision and recording of the works appropriate to the scale and complexity of the project and proposed end-use of the fill. The recording of the site works should be in accordance with the requirements of the earthworks specification. Guidance on the level of information that is required to demonstrate the quality of the works is available in BS EN 16907-5.

4.6.10.2 Site preparation

The site should be prepared in accordance with the earthworks specification, with all vegetation, topsoil, fly tipped and unsuitable materials removed prior to filling. If suitable, topsoil should be placed in segregated stockpiles for reuse onsite or elsewhere. Where excess topsoil is present, this may be removed under the Material Management Plan (MMP).

The formation should be prepared by proof rolling, with any hard or soft spots identified and remediated in accordance with the earthworks specification. Temporary drainage may be required to keep the formation dry.

Relic structures, for example old foundations and hard standings, should be removed from below engineered fill areas in their entirety wherever practicable. As a minimum, relic structures and obstructions should be removed to at least 2m below any proposed foundation. All structures or uncharacteristic elements (including boulders) greater than 1m in diameter/length left in the ground at formation should be surveyed and their positions recorded.

When recording the depth of engineered fill, it is essential (eg for use in subsequent pile designs) that the formation should be surveyed prior to filling on a maximum 10m grid arrangement.

Site constraints and features to be preserved (for example monitoring wells, public rights of way, watercourses and trees to be retained) must be clearly identified, and all necessary protection and safety measures implemented. Alternatively, their removal or any reinstatement measures should be specified as appropriate.

Where the sub-formation is sloped, the sides should be stepped at a maximum height of 600mm to allow the engineered fill to be benched into the existing natural ground or achieved otherwise as stated in the earthworks specification. Figure 5 shows what may be required on a sloping site close to the development platform where filling is required.

Figure 5: Benching of sloping natural ground

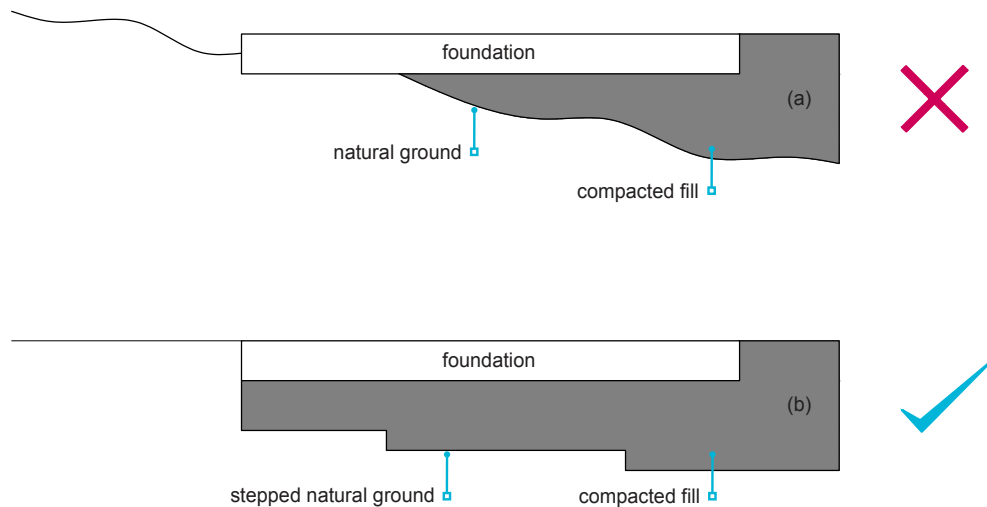

Notes

- a. Proposed development platform straddling over natural and fill areas
- b. Preferred development platform with well-prepared and stepped fill area beneath

4.6.10.3 Material handling

In addition to the required classification testing, site-derived materials should be routinely inspected during excavation to ensure consistency and correlation with the expected ground model.

Imported fill should be subject to periodic inspection from the donor site prior to arrival at the site and regular inspections once delivered. Classification testing should be undertaken as required prior to placement, particularly where the material is not provided with independent certification and where visual assessment suggests the material classification varies.

Engineered filling should not be undertaken in inclement weather conditions. Where the engineered fill is cohesive, placement and filling should be paused during extended periods of rain. For sensitive materials like chalk, care should be taken not to over-compact the fill further than specified.

Engineered fill must be placed and compacted in accordance with the specification, within a defined moisture content range close to the optimum moisture content (OMC) as derived from relevant laboratory testing.

For cohesive fill materials, the moisture content is critical in achieving the desired dry density. Engineered fill that is compacted too dry of the OMC risks being vulnerable to collapse settlement or heave when wetted. Engineered fill that is compacted too wet of the OMC risks being too weak to provide adequate support without excessive settlement.

Engineered fill should proceed in near horizontal layers (to assist in shedding surface waters), with each layer fully compacted before commencing the following layer. The maximum layer thickness for method compaction should be based on the type of fill material, the classification of the fill material, placement, and the method and plant employed.

For end product compaction, an uncompacted layer thickness of up to 250mm, subject to site-specific requirements, would be acceptable. The maximum particle size should not be greater than 1/3 of the compacted layer thickness or 75mm, whichever is lower.

Differing engineered fill material types should not be placed in the same layer. They should be placed at predetermined layers and defined depths appropriate to their properties and the proposed end-use.

Filling activities should be planned and carried out so that:

- vibrations do not disturb existing or nearby properties, excavations, slopes, buildings, services or infrastructure
- filling and earthwork machinery does not overload retaining features, slopes, buried services or infrastructure
- ground movement, including around the area of filling, does not harm adjacent buildings, services or infrastructure
- temporary slopes (filled or in cut) are safe and stable
- under-compaction and over-compaction are avoided
- the rate of placement of fill does not result in excess pore water pressure leading to failure of the underlying ground.

4.6.10.4 Material acceptability and compliance testing

Classification and compliance testing should be in accordance with BS EN 16907-5 and BS 6031:2009. Laboratory testing should be undertaken by a UKAS and/or MCERTS accredited specialist. All testing should be to a current British Standards or European Standards, eg BS 1377, using appropriately calibrated equipment. Testing should be undertaken throughout the duration of the fill placement in accordance with the guidance in Clause 4.6.12.

4.6.10.5 Actions in respect of non-compliant fill

Where testing indicates compacted engineered fill does not fully comply with the requirements of the earthworks specification, appropriate action should be agreed as soon as possible with NHBC. Possible actions include:

- drying of engineered fill material prior to further placement of subsequent layers
- excavation and replacement of the engineered fill represented by the test failure
- additional compaction (if the failure is shallow or at the surface) and retesting
- undertaking appropriate performance testing.

If the non-compliant engineered fill is regarded as a marginal outlier and represents part of a normal spread of test data, it may potentially be deemed acceptable without further action. It should be recorded in the Earthworks Verification Report.

The possible extent of non-compliant engineered fill needs to be carefully assessed, as well as whether the non-compliance may indicate unsuitable placement and compaction techniques, or poor site conditions, excessively variable fill or unsuitable material. Where there is a divergence from the earthworks specification, the designer should be notified and advice sought.

Remedial action needs to be carefully undertaken and recorded, avoiding disturbance to previously placed compliant engineered fill.

4.6.10.6 Protection of fill

Compacted engineered fill should be protected from deterioration due to trafficking, poor weather and pooling surface water. Suitable measures include laying the surface to falls to assist drainage or use of a durable granular sealing layer or sacrificial layer.

4.6.11 Adjacent excavations

The builder shall ensure that foundations within engineered fill are not disturbed by adjacent excavations.

The engineer should consider the influence of drainage and other service trenches on the stability of the complete works.

Excavations in engineered fill may require additional trench support, even at relatively shallow depths. Health and Safety Executive (HSE) advice with respect to the design and management of below ground temporary works, including those for excavations, man-entry, etc must be adhered to.

The earthworks verification report should identify and duly reference any constraints to excavation because of buried features, contamination or unusual ground conditions.

The minimum horizontal clearance between excavations and foundations must not be less than the depth of excavation minus the depth of the structural foundation. Particular attention is needed for excavation below the water table, where encountered.

Figure 6: Placement of excavation adjacent foundation on engineered fill

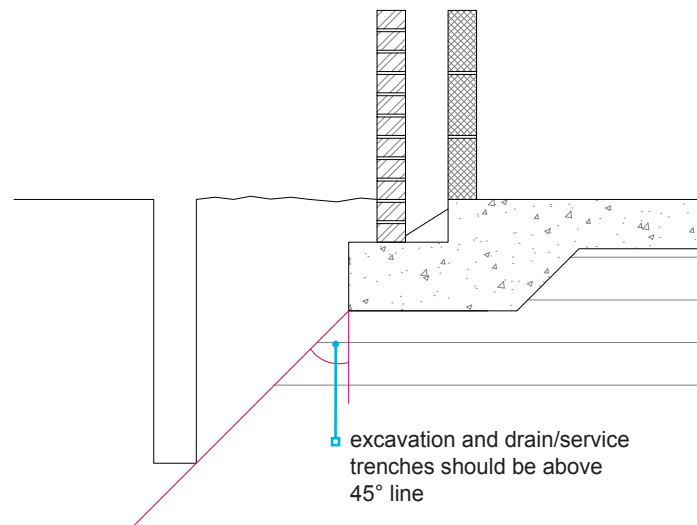

4.6.12 Verification of engineered fill

Also see: BS EN 16907-5, BS 6031 and BRE Digest 427

Verification testing of engineered fill shall be undertaken to confirm compliance with the earthworks specification and its fitness for purpose. Issues to be taken into account include:

- 1) fill classification
- 2) end product testing
- 3) performance testing
- 4) settlement measurement
- 5) testing frequency.

Validation and verification of the filling should be in accordance with BS EN 16907-5 and BS 6031:2009. Laboratory testing should be undertaken by a UKAS and/or MCERTS accredited specialist. All testing should be to a current British Standards or European EN Standards, eg BS 1377, using appropriately calibrated equipment.

Testing should be undertaken on a combination of random and targeted locations through the full depth of the fill to ensure consistency across the site. Higher-risk locations (for example deeper engineered fill, heavier/larger buildings, or where engineered fill was placed in less suitable conditions) should have a robust data set to confirm that fill has achieved the required geotechnical compliance criteria.

The testing frequency should be set out in advance of the works in the earthworks specification.

4.6.12.1 Fill classification

Classification testing, including particle size distribution (grading), plasticity (Atterberg Limits), 4.5kg rammer compaction tests or moisture content tests, should be undertaken throughout the earthworks to confirm that the engineered fill materials remain within the acceptability limits set out in the earthworks specification.

The type and frequency of classification tests should be site and material specific and should be confirmed in the earthworks specification. Acceptable test methods and frequencies of classification tests are given in Tables 9 and 10 of BS 6031:2009.

4.6.12.2 End product testing

Fill compaction is most commonly established by comparing the in-situ dry densities and moisture contents with the laboratory-determined maximum dry density and optimum moisture content. NHBC will normally accept engineered fill verified to achieve the criteria given in Table 6. There may be variation to these requirements where differing material types or foundations are adopted, or where there is a risk of future inundation of the fill.

The in-situ densities of engineered fill may be measured using sand replacement tests (SRTs), nuclear density tests (NDTs) or electromagnetic density gauges (EDGs). Where NDTs or EDGs are used, the results should be regularly calibrated against SRTs. Where there is variation in the fill materials, the use of NDT results to assess compaction may not be reliable.

4.6.12.3 Performance testing

Table 9 indicates suitable tests to assess earthworks performance. The type and frequency of testing should be appropriate for specific site conditions and the proposed end-use. It is recommended that a minimum of three tests of each type are undertaken, so that a trend can be observed from the results, with the exception of preloading by surcharge.

Table 9: Types of performance testing

Test/parameter	Description	Application
Preloading by surcharge	An area usually greater than 50m ² raised above the proposed development level with soils or fill to model the proposed development loadings	For large sites or areas of deep fill (over 5m deep) or where highly compressible soils exist at depth, usually in conjunction with other performance tests such as zone tests, plate tests or probing
Zone load	A rigid base (usually made up of concrete) with areas related to the width of the proposed foundations, typically between 4-10m ² Suited to modelling the loading and depth of influence of a building on raft foundation The test duration to be sufficient to identify the magnitude and timescale for completion of primary settlement, the clear trend of any secondary settlement (creep) and to confirm that load-settlement behaviour is in accordance with calculated predictions	For large sites or areas of deep fill usually in conjunction with other performance tests such as plate tests or probing undertaken to identify suitable locations for the zone test Care must be exercised during the zone tests, pads/bases are susceptible to ground vibrations/movement resulting from machinery/plant
Mini zone load/pad	Smaller than a zone test — with an area less than 4m ² and designed to model a typical (or heaviest) part of a spread (beam grillage or reinforced strip) foundation The test duration to be sufficient to identify the magnitude and timescale for completion of primary settlement, the clear trend of any creep and to confirm that load-settlement behaviour is in accordance with calculated predictions	Usually in conjunction with other performance tests such as plate tests or probing to identify suitable locations for the zone test Care must be exercised during the mini zone load tests, pads/bases are susceptible to ground vibrations/movement resulting from machinery/plant
Surface points settlement	A stable concrete or steel level monitoring point set at the surface or at shallow depth to determine the nature of any fill settlement without applied loading — usually over a prolonged period to model self-weight consolidation and creep settlement as required	Where self-weight consolidation or creep settlement may be significant — usually associated with deep cohesive fill
Settlement rods	Plates placed at the underside of engineered fill to measure settlement caused by the placement of fill	Usually in conjunction with other performance tests such as zone tests and mini zone load tests
Magnetic extensometers	Can be placed at varying depths within engineered fill or underlying made ground in deep fill sites to record settlement from targeted zones	Usually in conjunction with other performance tests such as zone tests and mini zone load tests
Plate test	Usually 600-900mm diameter plate and loaded incrementally to 1.5-3.0 times the highest proposed bearing pressure The peak load is held for up to 1 hour or until the rate of settlement does not exceed an agreed limit The use of dual cycle plate load tests can provide a significant improvement on the assessment and interpretation of the data. Wherever possible, dual cycle plate testing should be employed	Inexpensive but may not load the fill as deeply as a foundation, limited to approximately 1.5x the plate diameter Most suitable during fill placement
Probing	A range of techniques are available	Static cone testing can provide data on the surface to depth of soil, including soil stiffness and other important soil properties Shallow techniques (including hand-held) may be limited in data quality
Permeability	Infiltration testing in boreholes or trial pits at the depth of interest	Where low permeability is required to limit groundwater (or ground gas) movement
Inundation	Similar to permeability testing but with added settlement monitoring	To assess the susceptibility of fill to settlement when it becomes saturated (from surface water, service trenches or rising groundwater)
Hand vane	Undrained shear strength of cohesive fill; quick and easy but of limited reliability and accuracy	For cohesive fill Any gravel within the soil matrix that comes into contact with the cruciform pattern of the 4 vanes can significantly alter the results. It should only be used in conjunction with other tests as a confirmatory tool

Proposals for testing should be agreed in advance of the works and should be set out in the earthworks specification with supporting test plan(s). Test locations should be selected to allow a satisfactory spatial and lateral spread of results.

The pass criteria for the performance tests should be detailed in the earthworks specification and geotechnical design report/ geotechnical design statement and should be appropriate for the proposed end use and foundation type. Load-settlement zone load tests should be a minimum of 1.2 times the anticipated design load of the foundations and with the loaded area of a comparable scale.

4.6.12.4 Settlement measurement

Settlement measurement of load tests or surface points should be undertaken by a suitably qualified land surveyor to a suitable accuracy, no greater than to the millimetre and less where site conditions are considered appropriate or are likely to reduce uncertainty and the required duration of monitoring. It is critical that, over the long term, survey points are not damaged, disturbed, or affected by other activities. Additionally, the data should be related to stable datum outside the influence of any earthworks, or made ground or existing unstable ground. A minimum of two datum points should be established to provide redundancy in case one is lost or damaged.

Extensometers in boreholes can be effective at determining the depth at which settlements are occurring, where preloading or surcharge mounds are positioned upon underlying ground and self-weight consolidation is being assessed.

Plates with extension rods also provide means of measurement of settlement at sub-formation and the underlying ground.

Settlement data should be plotted at both natural time and logarithm time to aid assessment of the data.

4.6.12.5 Testing frequency

The frequency of testing for classification, compliance and performance purposes should be determined according to site conditions, fill materials and their consistency, filling techniques and the proposed end use as stated in the earthworks specification. Testing frequencies should be specified in accordance with industry guidance such as BRE Digest 427 and also see additional guidance within Clause 4.6.1.

Where a method specification is used, in-situ testing is required but typically would be based on the total volume of engineered fill to confirm that the degree of compaction achieved by the adopted method on site is as expected. When end product specification is used, in-situ testing should be based on a minimum number and grid, with each and every layer tested, eg 1 per 25m x 25m grid per layer and a minimum of three per layer per day. Where a performance specification is adopted, it will be necessary to undertake performance testing during fill placement, as well as upon completion, to ensure compliance with the earthworks specification.

The testing frequency based on Table 10 is generally considered as an acceptable minimum requirement.

Table 10: End product compliance testing of placed engineered fill*

Fill volume (m ³)	Minimum number of tests required
>100,000	2 per 1,000m ³
10,000 to 100,000	3 per 1,000m ³
<10,000	5 per 1,000m ³

*Note: Variation to the above may be necessary where differing material types or foundations are to be used.

Test types and frequencies should be reviewed according to the results obtained and site conditions. Where there is greater variation in site conditions or results than anticipated, an increased frequency of testing will be required. Conversely, and where agreed with NHBC, a decrease in test frequency may be acceptable where consistency in test results is being achieved.

4.6.13 Reporting*Also see: BS EN 16907-5 and BS 6031*

A detailed earthworks verification report shall be provided to NHBC on completion of the earthworks filling and testing. Where appropriate, the contents shall be agreed with NHBC prior to the work being done.

A comprehensive earthworks verification report for the filling works should be provided to NHBC as soon as practicable. It should provide an interpretation and assessment of the factual data contained within the report, as well as a detailed summary of the works undertaken, including testing. A site-wide or phased reporting approach is acceptable.

Where reinforced strip foundations are proposed, the report should be produced by a third-party organisation separate from those undertaking the works ie, by the overseeing supervising engineer, with all factual information made available. The report, where beam grillage or semi-raft foundations are proposed, can be produced solely by a suitably experienced earthworks contractor.

The content of the earthworks verification report shall be defined within the earthworks specification. Guidance on the contents and structure of the detailed report may be based on information within DMRB CD 622, where it is termed a geotechnical feedback report.

It is important that the report is in an appropriate format. Test results should be suitably summarised and presented to provide clear understanding using graphs and charts as necessary.

The earthworks verification report should give details as appropriate of the following:

1. The contractors and personnel responsible for the filling work, including details of supervision and testing
2. Preparation works prior to earthworks filling
3. Reference to the earthworks specification and method statement(s)
4. Sources of material used as engineered fill and their material classification
5. Any treatment, reconditioning or remediation of proposed engineered fill
6. Plant and methods used
7. As built survey records, including post-topsoil strip level or formation level for the earthworks, reduced levels following earthworks cuttings, final as-built or post-earthworks filling formation level, plan(s) and other drawings as appropriate that show the extent and depth of earthworks filling
8. All test results and certificates
9. Progress photographs and surveys
10. Progress reports and site diaries, with details of weather/site conditions and any agreed variations or changes to the specification
11. Graphical representation of the classification and compliance test data as show in Figure 7
12. Changes and amendments to design and earthworks specification
13. Records of remedial actions in areas of non-compliance
14. Problems experienced, and solutions and methods used to overcome the issues
15. Confirmation that the works comply with the earthworks specification and are suitable to support the proposed foundation types, where applicable (all non-compliances or departures from the earthworks specification should be clearly identified and suitably assessed)
16. Drawings showing known obstructions and any relevant features under or within the engineered fill
17. Graphical representation of the load-settlement tests, surcharge trials or post-completion monitoring over time with plots of settlement versus natural and logarithm presented to demonstrate that primary settlements are complete, with a clear trend of any remaining creep settlement projected to allow for a satisfactory building performance over a 60-year design life
18. Information required by the builder to safely undertake follow-on works in the ground, including any special precautions which should be undertaken or unusual constraints that exist, and any residual risks (for example further measures may be required where upfilling or an increase in ground levels post-remediation are likely to be proposed)

Figure 7: Basis for design: plot of moisture contents vs. dry densities for each fill type

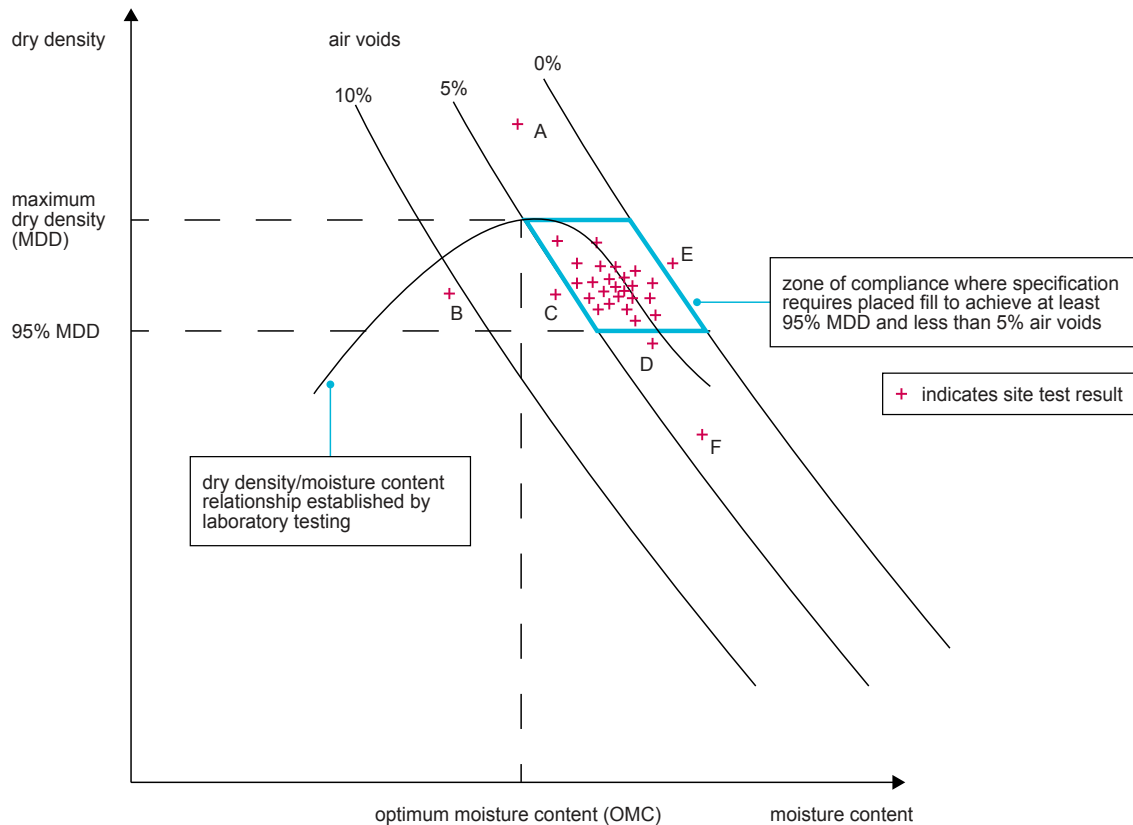

Notes

A – Indicates placed fill is of significantly higher density than achieved in the laboratory – the fill classification is likely not complying with the specification. Repeated results higher than the MDD indicates the laboratory testing was not on representative material or the method of laboratory compaction was too light.

B – Indicates placed fill has been compacted too dry of optimum and may therefore, where cohesive fill has been used, be liable to settlement when wetted.

C, D and E – Marginally outside of the compliance zone. As part of a large set of results that are otherwise compliant, these marginal failures may be acceptable, provided they are not part of non-compliant clusters.

F – Indicates fill placed wet of optimum and may be liable to settlement under load or over time.

Results of type A, B and F should be assessed further, and explanation provided of remedial actions, further testing or reasons for acceptance.

Further guidance on acceptability testing of proposed source fills and compliance testing of placed engineered fill is provided in BS 6031:2009. In setting the compliance curve of dry density/moisture content relationship, all tests should be presented or made available such that the target basis of design (for each fill type) can be agreed with NHBC, noting the degree of interpretation and assessment, including outliers. Updated targets may be appropriate in variable materials and should be detailed and agreed with the NHBC.

Compliance test results should be summarised and presented so that any non-compliances can be easily identified.

If the site has been filled some years before the intended construction works, or for an alternative end use such as commercial buildings, a retrospective validation may be appropriate. Assessment of historic fill within land reclamation schemes and marginal sites are generally outside the scope of this chapter. Consult NHBC or consider using the NHBC Land Quality Service for a bespoke consultation.

4.6.14 Further information

- BRE Special Digest 1 — Concrete in aggressive ground. 3rd edition
- BRE Digest 427 — Low-rise buildings on fill (parts 1-3)
- BRE Digest 433 — Recycled aggregates
- BS EN 771 — Specification for masonry units
- BS EN 16907-1 — Earthworks. Principles and general rules
- BS EN 16907-5 — Earthworks. Quality control
- ICE Earthworks — A guide (by Nowak & Gilbert)
- SHW Series 600 — Manual of Contract Documents for Highway works. Specification for highway works. Series 600



Part 5

Substructure, ground floors,
drainage and basements

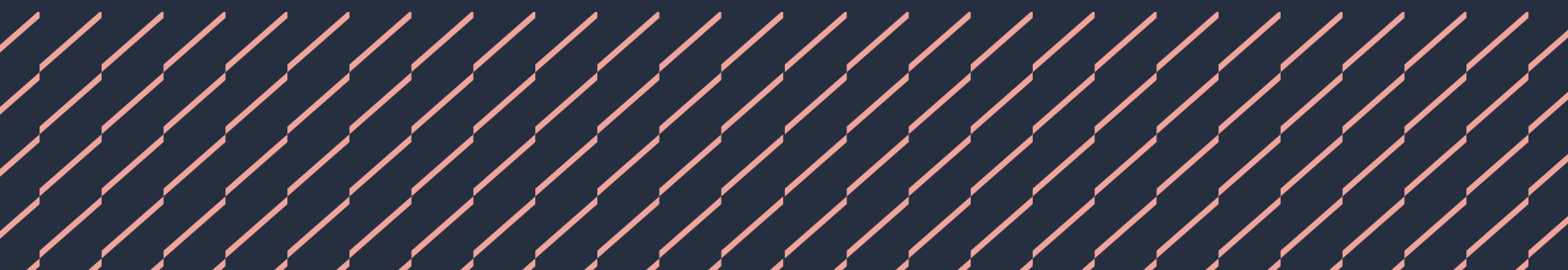

Substructure and ground-bearing floors

This chapter gives guidance on meeting the Technical Requirements and recommendations for substructures (excluding foundations), including: substructure walls, ground-bearing floors where infill is no deeper than 600mm, and installation of services below the damp proof course (DPC).

5.1.1	Compliance	02
5.1.2	Provision of information	02
5.1.3	Transfer of loads	02
5.1.4	Ground conditions	02
5.1.5	Services and drainage	04
5.1.6	Ground below fill	05
5.1.7	Fill below floors	05
5.1.8	Infill up to 600mm deep	05
5.1.9	Materials used for fill	05
5.1.10	Harmful or toxic materials	06
5.1.11	Regulatory solutions	06
5.1.12	Walls below the DPC	07
5.1.13	Durability	07
5.1.14	Mortar	08
5.1.15	Wall ties	08
5.1.16	Blinding	09
5.1.17	Ground floor slab and concrete	09
5.1.18	Laying the ground-bearing floor slab	09
5.1.19	Damp proof course	09
5.1.20	Damp proofing concrete floors	11
5.1.21	Thermal insulation	11
5.1.22	Installation of insulation	12
5.1.23	Further information	12



Figure reference table

Figure Reference Table 5.1

Fig No	Title/Description	Clause	Page
Figure 1	Substructure on sloping ground	5.1.4.4	3
Figure 2	Diversion of existing services	5.1.5.1	4
Figure 3	Pipes bedded in walls with flexible joints	5.1.5.3	4
Figure 4	Pipes passing through a lintelled opening	5.1.5.3	4
Figure 5	Backfill around pipes within openings	5.1.5.3	4
Figure 6	Infill under slab and backfill in trenches	5.1.7	5
Figure 7	Substructure walls acting as temporary retaining walls	5.1.12.1	7
Figure 8	DPM/DPC protected during installation of a concrete slab	5.1.18	9
Figure 9	DPC at least 150mm above finished ground level	5.1.19.1	10
Figure 10	Stepped DPC levels on sloping sites	5.1.19.1	10
Figure 11	225mm clear cavity below DPC	5.1.20	11
Figure 12	Protection of perimeter insulation board during installation of concrete floor	5.1.22	12

5.1.1 Compliance

Also see: Chapter 2.1

Substructures and ground-bearing floors shall comply with the Technical Requirements.

Substructures and ground-bearing floors that comply with the guidance in this chapter will generally be acceptable.

Ground-bearing floors may only be used where the depth of infill is less than 600mm deep and properly compacted.

5.1.2 Provision of information

Designs and specifications shall be produced in a clearly understandable format, include all relevant information and be distributed to appropriate personnel.

Design and specification information should be issued to site supervisors, relevant specialist subcontractors and suppliers, and include the following information:

- plan dimensions and levels which should be related to benchmarks
- the required sequence and depth of trench backfill where relevant to the design of the walls below the DPC
- details of trench backfill, infill and void formers
- work required to maintain the integrity of DPCs and damp proof membranes (DPMs)
- information on proposed underground services, including points of entry to the building
- detailing of service penetrations through the substructure, including support of the structure above details of junctions between the DPM, DPC and tanking
- details of underfloor, floor edge and cavity insulation
- details of ground hazards and mitigation measures.

5.1.3 Transfer of loads

Also see: Chapters 4.1, 4.3, 5.2 and 6.1

Substructures and ground-bearing floors shall ensure that loads are supported and transferred to the foundations, or ground, without undue movement.

The design of the substructure should take account of findings from the site investigation. Where infill deeper than 600mm is needed, a suspended floor should be used.

Load-bearing partitions should have proper foundations and not be supported off ground-bearing floors. In Scotland, sleeper walls should not be built on ground-bearing floors.

5.1.4 Ground conditions

Also see: Chapters 4.1, 4.2, 5.2, 10.1 and BRE Report 211

Substructure and ground-bearing floors shall not be adversely affected by ground conditions, and take account of:

- | | |
|---|---|
| <ol style="list-style-type: none"> 1) ground hazards 2) bearing capacity of the ground 3) nature of the ground | <ol style="list-style-type: none"> 4) effect of sloping ground on depth of infill and wall construction 5) desiccated ground 6) site works and construction. |
|---|---|

5.1.4.1 Ground hazards

Hazards likely to affect substructure and ground-bearing floors include contaminated materials, waterlogged ground and chemicals, particularly sulfates.

Where it is necessary to reduce the entry of hazardous gas, which should be identified in the site investigation, such precautions should be acceptable to NHBC.

5.1.4.2 Bearing capacity of the ground

Ground-bearing floors may not be suitable where the bearing capacity and nature of the ground varies, even where the depth of infill is less than 600mm. Special measures may be needed to restrict settlement, such as the use of suspended floor construction.

5.1.4.3 Nature of the ground

Where there is shrinkable soil, expansive materials or other unstable soils, suspended floor construction may be necessary.

Shrinkable soils are classified as those which contain more than 35% fine particles (silt and clay) and which have a Modified Plasticity Index of 10% or more. A soil testing laboratory should be consulted to verify the Plasticity Index of the soil.

5.1.4.4 The effect of sloping ground on depth of infill and wall construction

Sloping ground may require steps in the substructure and possibly different floor levels.

Where more than 600mm of infill is required at any point in a self-contained area, the floor over the whole of that area must be of suspended construction.

Construction on steep slopes may involve walls below DPC level acting as retaining walls and should be designed by an engineer where (H) is greater than four times (T) or (H) exceeds 1m.

- (H) = height difference between floor/ground levels
- (T) = the total thickness of the retaining wall.

Figure 1: Substructure on sloping ground

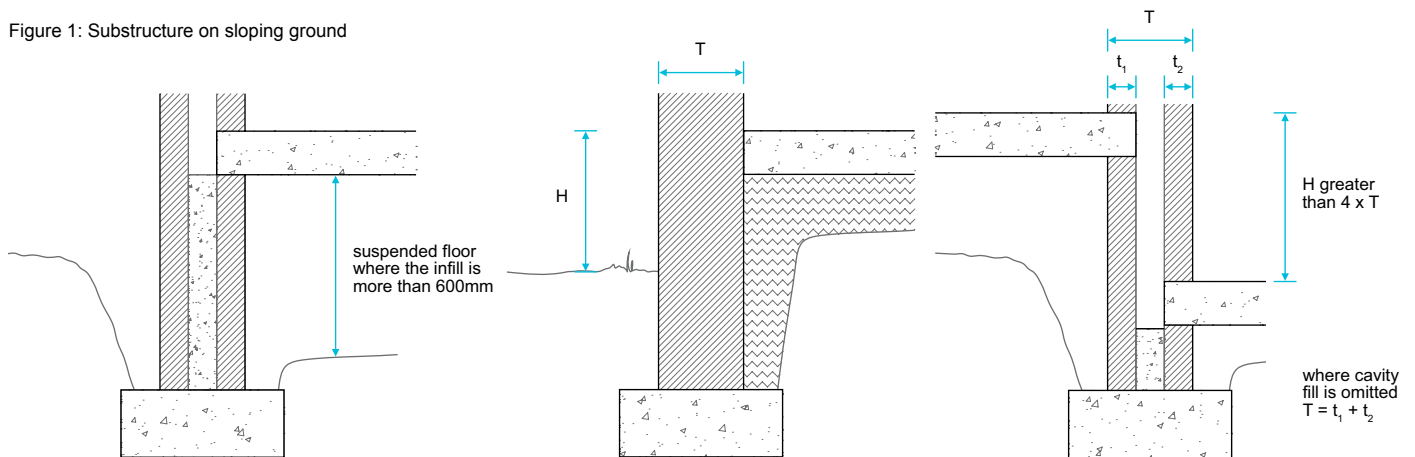

5.1.4.5 Desiccated ground

In areas known to have high volume change potential clays as substrates, tests should be carried out to determine whether the soil is desiccated from vegetation other than trees.

On sites where vegetation has been recently removed, the soils may be desiccated and unsuitable for ground bearing slabs leading to undue movement caused by ground heave. Where there is a risk of this happening, a suspended slab should be adopted with appropriate void underneath, in accordance with Clause 4.2.10.

Alternatively, a suspended cast in-situ concrete ground slab may be used where appropriate void formers are incorporated under the floor slab.

5.1.4.6 Site works and construction

Special precautions may be needed to prevent damage to the substructure from site operations on adjoining ground such as ground treatment, or surcharging due to infill.

5.1.5 Services and drainage

Also see: Chapters 5.3, 5.4, 6.2 and 8.1

Substructure and ground-bearing floors shall be installed to:

- 1) adequately protect existing services and groundwater drainage
- 2) have suitable surface and subsoil drainage
- 3) make allowance for drainage and other services.

5.1.5.1 Adequately protect existing services and groundwater drainage

All existing services should be located and identified before work commences. During dry periods, it can be difficult to determine if groundwater drains are active, so where they are severed or disturbed, they should be reconnected to a suitable outfall.

Existing active groundwater drainage should be retained to minimise the risk of flooding. Water from these drains may require diverting.

Where existing services conflict with the proposed foundations or substructure, and they are to remain, they should be protected or diverted and remaining voids filled with concrete or grout. Where they are no longer active and are not needed, they should be disconnected and removed.

Figure 2: Diversion of existing services

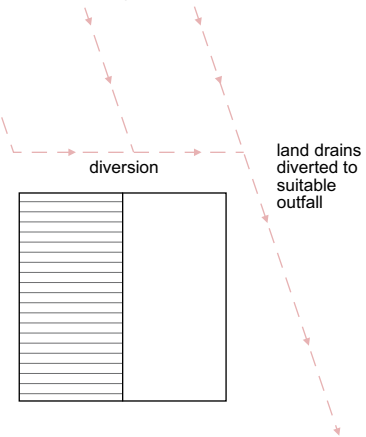

5.1.5.2 Surface water and subsoil drainage

Surface and/or subsoil drainage may be needed on sites where there is a risk of waterlogging.

Walls which act as retaining walls may require land drains, hardcore fill and suitable outlets to dispose of any subsoil water that collects behind the wall.

Ground or paths adjoining the home should:

- slope away at a slight fall
- generally be at least 150mm below the DPC.

5.1.5.3 Make allowance for drainage and other services

Design information should include all necessary details relating to the proposed underground services.

Drain pipes passing through or under the building may require flexible connections or other means of accommodating differential movement.

Pipes passing through substructure walls should accommodate movement by:

- a 50mm clearance all round, or
- a sleeve, with 50mm clearance all round and suitably sealed, or
- bedded pipes, connected on both sides of the wall with flexible joints located as close as is feasible to the outside face of the wall but at a maximum of 150mm from the face of the wall.

Flexible joints should be made in accordance with the pipe manufacturer's recommendations.

Figure 3: Pipes bedded in walls with flexible joints

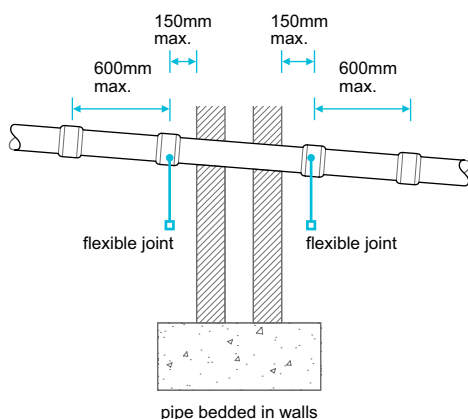

Figure 4: Pipes passing through a lintelled opening

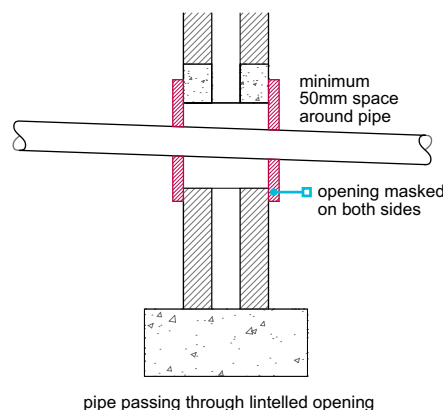
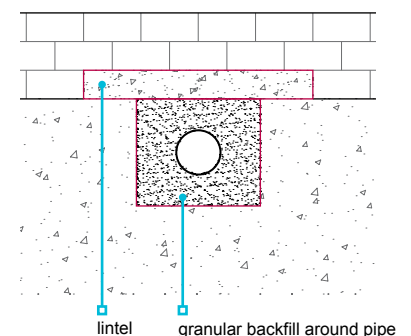

Figure 5: Backfill around pipes within openings



Where required, they should be arranged so that future access can be obtained without affecting structural stability.

When unidentified services, ducts, cables or pipes are exposed, advice should be sought from local offices of statutory undertakings and service supply companies.

5.1.6 Ground below fill

Ground below fill shall be adequately prepared to provide consistent support to the fill and ground-bearing slabs without undue movement.

Ground-bearing floor slabs may only be built on ground where:

- the ground is suitable to support floor loads and any other loads
- all topsoil containing vegetation and organic matter, including tree roots, has been removed
- there is a suitable and even bearing surface.

5.1.7 Fill below floors

Fill, including made ground, trench backfill and infill below ground-bearing floor slabs, shall provide full and consistent support to ground-bearing slabs.

Where more than 600mm of infill is required at any point within a self-contained area, or the bearing capacity and nature of the ground varies, the floor over the self-contained area should be of suspended construction.

Infill under slabs and backfill in trenches should be properly placed and mechanically compacted to form a stable mass in layers not exceeding 225mm. Concrete may be used as an alternative to backfill in trenches.

Figure 6: Infill under slab and backfill in trenches

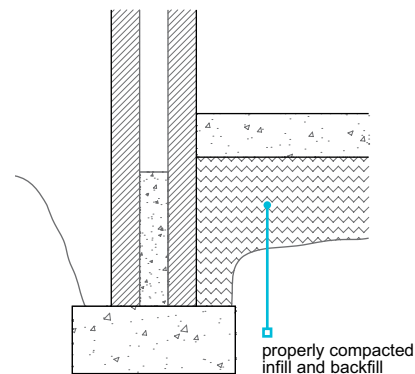

5.1.8 Infill up to 600mm deep

Also see: Chapter 5.2

Infill beneath ground-bearing floors shall be a maximum of 600mm deep.

Ground-bearing slabs are not acceptable where infill exceeds 600mm in depth.

Where the design requires in excess of 600mm of infill at any point within a self-contained area, the floor construction over the whole of that area is required to be independent of the fill and capable of supporting:

- self-weight
- other imposed loads.
- non load-bearing partitions

Generally, this should be achieved with the use of a suspended slab (see Chapter 5.2 Suspended ground floors).

5.1.9 Materials used for fill

Also see: Chapter 4.6, BRE DG 522

Materials used for fill shall be suitable for the intended use and, unless appropriate precautions are taken, free from hazardous materials. Issues to be taken into account include:

- 1) sources of fill materials
- 2) hazardous materials.

Fill should be:

- well graded
- inert and contain no hazardous materials
- able to pass a 150mm x 150mm screen in all directions.

Fill containing either expansive materials or chemicals is not acceptable for the support of ground-bearing slabs.

The following types of fill should not be used unless written permission has been obtained from NHBC:

- material obtained from demolition
- slags
- furnace ashes and other products of combustion
- on wet sites, or sites with a high water table, crushed or broken bricks which have S1 designation according to BS EN 771.
- colliery shale and any other residue from mineral extraction

5.1.9.1 Sources of fill material

Where the material is of a stable and uniform type, and from one source, it may only be necessary to check its suitability once. Where material is variable, or from a number of sources, it should all be suitable, and regular inspections and/or testing may be required.

Where industrial waste is permitted as fill material, it is essential that sufficient testing is carried out to ensure suitability.

Where material is obtained from stockpiles, check the material is uniform. Different forms of stockpiling can affect particle size/grading. The outside of a stockpile may be weathered and may not be the same as unweathered material.

5.1.9.2 Hazardous materials

The following fill materials require testing to ensure their suitability for use with ground-bearing slabs or as backfill to associated trenches:

- reactive materials
- organic materials
- toxic materials
- materials that include sulfates, eg gypsum
- materials that cause noxious fumes, rot, undue settlement or damage to surrounding materials
- acid wastes.

5.1.10 Harmful or toxic materials

Also see: BRE DG 522

Harmful or toxic materials present in the fill or in the ground shall be identified to the satisfaction of NHBC and not affect the performance of the substructure and ground-bearing slab.

Precautions should be taken by either:

- ensuring that made ground and fill materials are free from harmful or toxic substances, or
- designing the construction to contain, resist and prevent the adverse effects of such materials, using means acceptable to NHBC.

Tests for sulfate content should comply with the recommendations of BRE Special Digest 1 Concrete in Aggressive Ground Third Edition by a suitably qualified person who has a detailed knowledge of the:

- material being tested
- proposed conditions of use.

The samples tested must be representative of the material, so it may be necessary to collect multiple samples to identify characteristics.

Where there are likely to be harmful levels of sulfate:

- the floor slab should be of an appropriate mix to resist sulfate attack or be protected by an impervious layer of 1,200 gauge (0.3mm) polyethylene sheet, or 1,000 gauge (0.25mm) where it complies with Technical Requirement R3; this may also serve as a DPM
- the concrete blocks in substructure walls should be sulfate resistant and suitable for the fill and ground conditions
- the mortar should be sulfate resisting to comply with BS EN 1996-1-1.

Fill containing expansive materials or chemicals is not acceptable for use as infill or backfill.

5.1.11 Regulatory solutions

Use of recycled or secondary materials shall comply with the relevant waste regulatory requirements.

Table 1: Regulatory solution for fill, including recycled and secondary materials

Location	Materials used on	Regulatory solution
England and Wales	Site of origin	CL:AIRE Code of Practice
	Other sites and less than 5,000t	Registration under a U1 exemption with the EA is required at the receiving site
	Other sites and over 5,000t	Ensure that the supplier has followed the WRAP protocol
Northern Ireland and Scotland	Any site	Registration under a paragraph 19 exemption with the SEPA/NIEA is required at the receiving site

EA: Environment Agency
 CL:AIRE: Contaminated Land: Applications in Real Environments
 NIEA: Northern Ireland Environment Agency
 SEPA: Scottish Environment Protection Agency
 WRAP: Waste & Resource Action Programme

5.1.12 Walls below the DPC

Also see: Chapters 6.1 and 6.2

Substructure and walls below the DPC shall be suitably constructed. Issues to be taken into account include:

- 1) construction of walls acting as temporary retaining walls
- 2) concrete cavity fill.

5.1.12.1 Construction of walls acting as temporary retaining walls

Backfill should be placed in layers of equal thickness to both sides of the substructure walls, so that compaction on one side is not more than one layer ahead of the other. Where backfill is placed and compacted on one side of the foundation trench before the other side is backfilled, the wall will be acting as a temporary retaining wall.

In such cases, the wall should either be designed by an engineer in accordance with Technical Requirement R5 or the thickness (T) should be as indicated in Table 2.

Figure 7: Substructure walls acting as temporary retaining walls

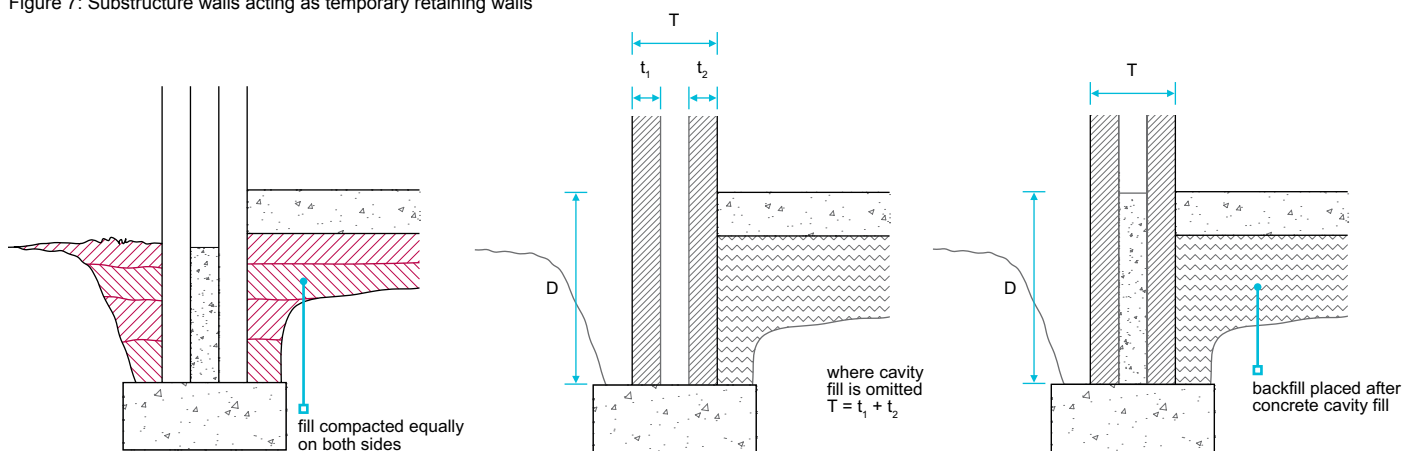

Table 2: Acceptable D:T of temporary retaining walls

Depth (D) of filled trench	Minimum thickness (T) of wall leaf supporting fill
Up to 1,100mm	200mm
1,100-1,400mm	300mm
1,400-1,700mm	400mm
1,700-2,000mm	500mm

This guidance is only applicable to the temporary condition and where problems such as hydrostatic pressure are not present.

5.1.12.2 Concrete cavity fill

A minimum 225mm clear cavity below the DPC should be maintained. When specialised foundations are used, including those for timber framed buildings, the minimum clear cavity depth may be reduced to 150mm below the DPC, provided that weepholes and other necessary measures are taken to ensure free drainage. For further guidance, see Clause 4.4.13.

5.1.13 Durability

Also see: Chapters 4.3, 6.1 and BS EN 1996-1-1

Substructure and walls below the DPC shall be capable of supporting their intended loads and, where necessary, be resistant to frost action, sulfates and other harmful or toxic materials. Issues to be taken into account include:

- 1) brickwork
- 2) blockwork.

Frost damage occurs on saturated masonry exposed to freezing conditions. Bricks, blocks and mortars located 150mm above and below ground level are the most likely to be damaged by frost.

Masonry walls below the DPC should be designed and constructed as described in Chapter 6.1 External masonry walls.

Recommendations for the design strength of bricks, masonry blocks and mortars are given in BS EN 1996-1-1.

5.1.13.1 Brickwork

Bricks should be of suitable durability, especially in the outer leaf below the DPC, or where they could be frozen when saturated. Bricks used in retaining walls should be suitable for the exposure and climate, as recommended by the manufacturer.

Clay bricks should comply with BS EN 771, which classifies bricks according to their durability designation (F) and to the content of active soluble salts (S).

F0	Not freeze/thaw resistant and should not be used externally
F1	Moderately freeze/thaw resistant
F2	Freeze/thaw resistant
S1	Normal active soluble salts
S2	Low active soluble salts

Generally, bricks are designated to F1, S2 or F1, S1. If in doubt as to suitability, bricks of F2, S2 or F2, S1 should be specified, or the manufacturer consulted and written confirmation obtained in relation to:

- geographical location
- location in the structure.

Calcium silicate bricks for use below DPC should be at least compressive strength Class 20.

5.1.13.2 Blockwork

Concrete blocks for use below the DPC should meet BS EN 771 and one of the following:

- minimum density of 1,500kg/m³, or
- minimum compressive strength of 7.3N/mm², or
- assessed in accordance with Technical Requirement R3.

Where it is necessary to resist sulfate attack and ensure adequate durability, blocks made with sulfate-resisting cement and/or a higher than normal cement content should be used.

Where there is doubt regarding the suitability of the block, particularly where acids or sulfates occur, written confirmation of its suitability should be obtained from the manufacturer in relation to:

- geographical location
- location in the structure.

5.1.14 Mortar

Also see: Chapter 6.1

Substructure and walls below DPC level shall use mortar which is suitable for the location and intended use.

Issues to be taken into account include:

- 1) mortar mix
- 2) sulfate resistance.

5.1.14.1 Mortar mix

Mortar should comply with the design and should take account of the strength, type and location of the masonry. The selection of mortar for use below the DPC should follow the recommendations given in BS EN 1996-1-1.

The use of proprietary mortars and admixtures should:

- account for the type of masonry unit and its location
- only be used in accordance with the manufacturer's recommendations.

For non-clay bricks or blocks, mortar should be used in accordance with the brick manufacturer's recommendations.

5.1.14.2 Sulfate resistance

Cements which resist sulfates should be used where:

- sulfates are present in the ground, groundwater or masonry
- recommended by the brick manufacturer.

In such cases, cements which resist sulfates to BS EN 197 should be used.

5.1.15 Wall ties

Substructure and walls below the DPC shall use wall ties suitable for their intended use.

Wall ties should comply with BS EN 845-1 or be assessed in accordance with Technical Requirement R3.

Where cavity insulation batts or slabs start below DPC level, the vertical and horizontal spacing of wall ties should be compatible with the spacing to be used above DPC level.

5.1.16 Blinding

Blinding shall provide a suitable surface for the materials above.

Infill should be sufficiently blinded to receive the concrete, and DPM where required, using the minimum thickness necessary to give a suitable surface.

Concrete blinding may be needed where voids in the fill could result in loss of fines from the blinding. Where hardcore fill is used, smooth blinding, eg sand or other suitable fine material, is essential to avoid puncturing a sheet DPM.

Where the ground floor is to be reinforced, blinding should be firm and even, to give good support for the reinforcement and to maintain the design cover using reinforcement stools, where appropriate.

5.1.17 Ground floor slab and concrete

Also see: Chapter 3.1

Ground-bearing floors shall be of adequate strength and durability, and use concrete mixed and reinforced as necessary to support floor loads safely and resist chemical and frost action.

Ground-bearing concrete floor slabs should be at least 100mm thick, including monolithic screed where appropriate.

5.1.18 Laying the ground-bearing floor slab

Also see: Chapters 3.1 and 9.3

Ground-bearing floors shall be reasonably level and effectively impervious to moisture.

All underfloor services and ducts should be installed and tested before concreting, where appropriate.

Care should be taken to ensure that all joints and junctions between DPMs, wall DPCs or tanking in substructure walls are undamaged, especially while the concrete for the ground slab is being poured.

Figure 8: DPM/DPC protected during installation of a concrete slab

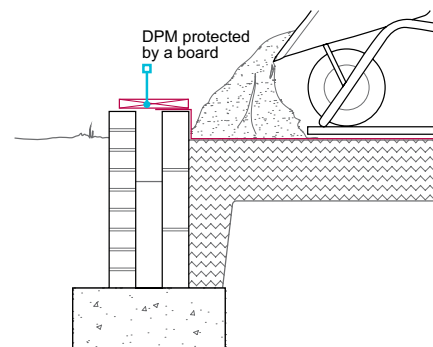
**5.1.19 Damp proof course**

Also see: Chapters 5.4, 6.1 and 6.3

Damp proof courses shall adequately resist moisture from reaching the inside of the building. Issues to be taken into account include:

- 1) positioning of DPCs
- 2) DPC materials.

5.1.19.1 Positioning of DPCs

DPCs should be:

- positioned a minimum of 150mm above external finished ground or paving level
- linked with any DPM
- of the correct width and fully bedded
- either welded or lapped by 100mm minimum
- impermeable.

Figure 9: DPC at least 150mm above finished ground level

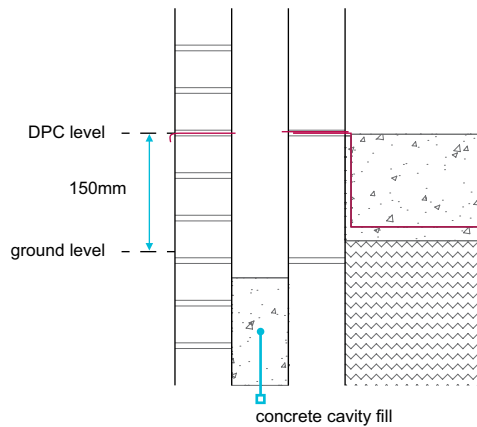
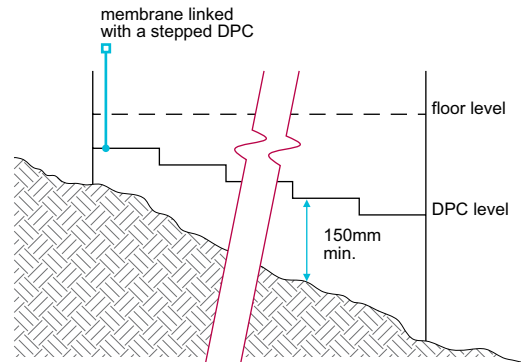

Figure 10: Stepped DPC levels on sloping sites



Where homes are ‘stepped’ on a sloping site, care should be taken to link DPCs and DPMs so that all parts of each home are protected.

5.1.19.2 DPC materials

Acceptable materials for DPCs include:

Bitumen based materials	BS 6398, BS EN 14967
Polyethylene (except as cavity trays in walls, below copings and in parapets)	BS 6515, BS EN 14909
Thermoplastics and elastomers	BS EN 14909
Proprietary materials	Proprietary materials Technical Requirement R3

DPCs and flexible cavity trays should be of the correct dimensions. At complicated junctions, preformed cavity trays of the correct type and shape should be used.

Brick DPCs are only suitable to resist the upward movement of moisture and should:

- consist of two courses of engineering bricks, laid broken bond
- be bedded and jointed in a 1:¼:3, cement:lime:sand, or equivalent, mortar.

5.1.20 Damp proofing concrete floors

Ground-bearing floors shall resist the passage of moisture to the inside of the home.

Ground-bearing concrete floor slabs should be protected against ground moisture by providing a continuous damp proof membrane (DPM), which should:

- have sealed laps of at least 300mm wide
- link with wall DPCs to form an impervious barrier to prevent moisture reaching the interior of the dwelling
- take account of possible differential movement.

Care should be taken not to trap moisture when a combination of damp proofing and vapour control layers (VCLs) is used.

When the DPM is located below the slab, a blinding layer of sand should be provided to fill voids in the hardcore and to minimise the risk of puncturing the membrane.

A clear cavity of at least 225mm below the DPC should be maintained. When specialised foundations are used, including those for timber framed buildings, this depth may be reduced to 150mm below the DPC where weepholes are provided and other necessary measures are taken to ensure that the cavity can drain freely.

Where homes are stepped down a sloping site, the DPCs and DPMs should be linked so that all parts of each home are protected. The guidance in Chapter 5.4 Waterproofing of basements and other below ground structures should be followed where steps between floor slabs are greater than 150mm.

Suitable materials for DPMs include:

- 1,200 gauge (0.3mm) polyethylene sheet
- minimum 1,000 gauge (0.25mm) polyethylene sheet where it complies with Technical Requirement R3
- bitumen sheet to BS 6398
- materials that comply with Technical Requirement R3.

Figure 11: 225mm clear cavity below DPC

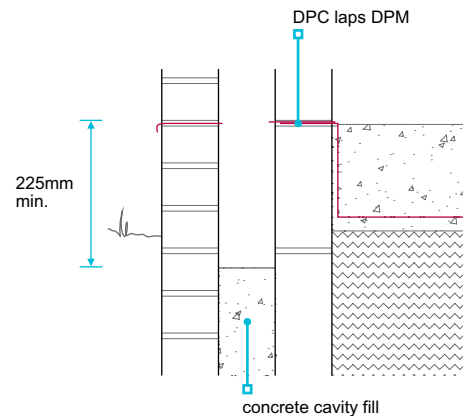

5.1.21 Thermal insulation

Also see: Chapters 6.1, 9.3 and BRE Report 262

Ground-bearing floors and walls below the DPC shall be thermally insulated to comply with Building Regulations and be suitable for the intended use. Issues to be taken into account include:

- 1) floor insulation
- 2) wall insulation
- 3) thermal bridging.

5.1.21.1 Floor insulation

Thermal insulation materials for use below ground-bearing slabs should have:

- appropriate density for the location
- low water absorption.

Insulation to be positioned below both the slab and DPM should be resistant to ground contaminants. The following materials are acceptable for use as insulation:

- expanded polystyrene boards (grade EPS 70) to BS EN 13163
- a proprietary material that complies with Technical Requirement R3.

5.1.21.2 Wall insulation

Cavity insulation materials, super lightweight blocks, blocks with face bonded insulation or integral insulation should be:

- manufactured and used to comply with a British Standard and relevant code of practice, or
- used in compliance with Technical Requirement R3.

The thickness of materials for masonry cavity walls should be suitable for the required level of performance (see Clause 6.1.7).

5.1.21.3 Thermal bridging

The design should ensure that any risk of thermal bridging is minimised, especially at junctions between floors and external walls. Precautions include:

- extending cavity insulation below floor slab level
- linking floor and wall insulation
- providing perimeter insulation to floors
- facing supporting substructure with insulation — where homes are stepped or staggered, the wall forming the step or stagger may require insulation
- ensuring thermal bridging is addressed at door openings.

5.1.22 Installation of insulation

Installation of thermal insulation shall ensure that the full thermal performance of the floor is achieved.

Insulation boards should be tightly butted together to maintain insulation continuity. Where the insulation is turned up vertically at the edge of the slab, it should be protected whilst the concrete is being poured and tamped.

Figure 12: Protection of perimeter insulation board during installation of concrete floor

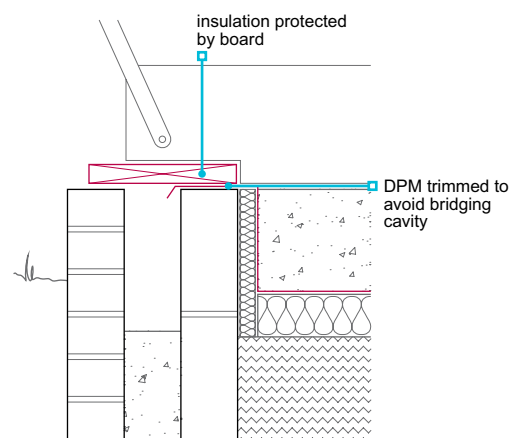

5.1.23 Further information

- BRE Digest 433 Recycled aggregates. 1998 Edition
- BRE Report BR 211 Radon: Guidance on protective measures for new buildings (including supplementary advice for extensions, conversions and refurbishment projects). 2023 Edition
- BRE Report BR 262 Thermal insulation: avoiding risks. 3rd Edition
- BRE Digest 522 Hardcore for supporting ground floor of buildings. Parts 1 and 2. 2011 Edition
- BS EN 1996-1-1:2022 Eurocode 6. Design of masonry structures — General rules for reinforced and unreinforced masonry structures



Chapter 5.2



Suspended ground floors

This chapter gives guidance on meeting the Technical Requirements for suspended ground floors, including those constructed from:

- in-situ concrete
- precast concrete
- timber joists.

5.2.1	Compliance	01
5.2.2	Provision of information	01
5.2.3	Contaminants	01
5.2.4	Proprietary systems	01
5.2.5	Transfer of loads: concrete floors	01
5.2.6	Reinforced concrete	02
5.2.7	Construction of suspended concrete ground floors	02
5.2.8	Transfer of loads: timber floors	02
5.2.9	Thermal insulation and thermal bridging	03
5.2.10	Damp proofing and ventilation	03
5.2.11	Floor finishes	04
5.2.12	Floor decking	04
5.2.13	Further information	04



5.2.1 Compliance

Also see: Chapters 2.1, 4.1, 4.2, 4.5 and 5.1

Suspended ground floors shall comply with the Technical Requirements.

Suspended ground floors that comply with the guidance in this chapter will generally be acceptable.

Ground floors should be constructed as suspended floors where:

- the depth of fill exceeds 600mm
- there is shrinkable soil that could be subject to movement (see Chapter 4.2 Building near trees), expansive materials or other unstable soils
- the ground has been subject to vibratory improvement
- ground or fill is not suitable to support ground-bearing slabs.

5.2.2 Provision of information

Designs and specifications shall be produced in a clearly understandable format, include all relevant information and be distributed to all appropriate personnel.

Design and specification information should be issued to site supervisors, relevant specialist subcontractors and suppliers, and include the following information:

- all necessary plan dimensions and levels related to identified benchmarks
- details of load-bearing walls
- minimum bearing dimensions
- information on all proposed underground services
- points of entry to the building for services
- details of trench backfill, infill and void formers
- details of junctions between DPM, DPC and tanking
- details of underfloor and floor edge insulation and cavity insulation, where relevant
- span and direction of structural members
- details of non load-bearing walls
- details of ground hazards and mitigation measures.

5.2.3 Contaminants

Also see: Chapters 4.1, 10.1 and BRE Report 211

Suspended ground floors shall be designed and constructed to ensure that adequate measures are taken against the adverse effects of ground contaminants, including adequate protection against hazardous gas.

Any contaminants in, or above, the ground should be identified to the satisfaction of NHBC, following the guidance given in the appropriate British Standard, and precautions against health hazards caused by contaminants should be taken.

Precautions acceptable to NHBC may be necessary to reduce the entry of hazardous gas; such conditions should be identified in the site investigation.

5.2.4 Proprietary systems

Proprietary suspended flooring systems shall have adequate strength and durability.

Proprietary concrete flooring systems should be designed in accordance with BS EN 1992-1-1. Where a system incorporates elements which cannot be designed to this standard, eg polystyrene infill blocks, the floor should be assessed in accordance with Technical Requirement R3.

5.2.5 Transfer of loads: concrete floors

Also see: Chapters 4.1, 4.2, 5.2 and BRE Report 211

Suspended ground floors shall be designed and constructed to transmit all loads safely to the supporting structure without undue movement. Issues to be taken into account include:

- 1) dead and imposed loads
- 2) end bearings.

5.2.5.1 Dead and imposed loads

In-situ:

Loads should be calculated in accordance with BS EN 1991-1-1.

Suspended in-situ concrete ground floors should be designed either:

- by an engineer in accordance with Technical Requirement R5, or
- in accordance with BS 8103-1.

Precast:

Loads should be calculated in accordance with BS EN 1991-1-1.

Precast concrete suspended ground floors should be:

- designed by an engineer in accordance with Technical Requirement R5
- proprietary systems which have been assessed in accordance with Technical Requirement R3, or
- chosen from the manufacturer's details, which are based on recognised standards and codes of practice.

5.2.5.2 End bearings**In-situ:**

Bearings on supporting walls should be designed either:

- by an engineer in accordance with Technical Requirement R5, or
- in accordance with BS 8103-1.

Precast:

Bearings on supporting walls should be as recommended by the manufacturer, and in no case less than 90mm.

5.2.6 Reinforced concrete

Also see: Chapter 3.1

Suspended ground floors shall use suitably mixed and reinforced concrete, which will achieve sufficient strength to support floor loads safely and be sufficiently durable to remain unaffected by chemical or frost action.

Guidance for the specification and use of in-situ concrete, additives and reinforcement is contained in Chapter 3.1 Concrete and its reinforcement.

5.2.7 Construction of suspended concrete ground floors

Also see: Chapter 6.4

Suspended ground floors shall be designed and constructed to ensure the safe support of the intended loads and be reasonably level.

In-situ:

Concreting should be carried out in accordance with:

- the design information
- relevant parts of NHBC guidance for concrete, including Chapter 3.1 Concrete and its reinforcement.

Precast:

Care should be taken to ensure that DPCs are not damaged or displaced. All sitework for precast concrete floors should be carried out in accordance with the manufacturer's recommendations.

5.2.8 Transfer of loads: timber floors

Also see: Chapters 4.3 and 6.4

Timber suspended ground floors, including the decking material, shall be designed and constructed to be suitable for their intended use. Issues to be taken into account include the:

- 1) support of self-weight, dead and imposed loads and limited deflection
- 2) safe transmission of loads to the supporting structure
- 3) adverse effects of shrinkage and movement.

5.2.8.1 Support of self-weight, dead and imposed loads and limited deflection

Structural timber grades and sizes should be adequate for the spans and imposed loads. Where trimming is necessary, adequately sized timbers should be used.

Structural timber components should be of a suitable strength class as specified by the designer to BS EN 338. Solid structural timber should be:

- machine graded to BS EN 14081, or visually graded to BS 4978 for softwoods or BS 5756 for hardwoods
- assigned a strength class based on BS EN 1912 when visually graded
- dry graded
- marked in accordance with BS EN 14081.

Further guidance on strength classes for certain timber species can be found in PD 6693.

Engineered wood products such as I-section or metal-web joists should be assessed in accordance with Technical Requirement R3.

For guidance on floor joist deflection limits, see Clause 6.4.9.

5.2.8.2 Safe transmission of loads to the supporting structure

Joist hangers should be suitable for:

- the joist width and depth
- the strength of masonry
- the loading
- providing adequate end bearings to joists.

Sleeper walls should adequately support the floor joists, and joists should be correctly supported at masonry separating walls. Sleeper walls should not limit ventilation.

5.2.8.3 Shrinkage and movement

Strutting should be provided where required following the guidance in Clause 6.4.15.

5.2.9 Thermal insulation and thermal bridging

Also see: Chapter 9.3 and BRE Report BR 262

Suspended ground floors shall be insulated in accordance with Building Regulations to minimise thermal transmission through the floor, using materials suitable for the location and intended use.

Insulation should be installed to ensure that any risk of thermal bridging is minimised, especially at junctions between floors and external walls. Thermal bridging precautions include:

- extending cavity wall insulation below floor level
- providing perimeter insulation to floors.

Insulation below cast in-situ suspended ground floor slabs should be:

- placed on a suitable, compacted and even substrate
- of a material with low water absorption
- resistant to ground contaminants
- strong enough to support wet construction loads
- compatible with any DPM.

Insulation for timber floors may be either insulation quilt or rigid insulation.

Cavity wall insulation should extend below the floor insulation level.

Insulation for use above suspended concrete floors should be in accordance with Chapter 9.3 Floor finishes.

Particular attention should be paid to ensuring thermal bridging is addressed at door openings.

5.2.10 Damp proofing and ventilation

Also see: Chapters 4.2, 5.1, 5.4, 6.1, 6.3 and 9.3

Suspended ground floors shall be designed and constructed to resist the passage of moisture into the building. Issues to be taken into account include:

- 1) damp proofing
- 2) ventilation.

5.2.10.1 Damp proofing

Where DPMs are required, they should be linked with any DPCs in the supporting structure, in order to provide continuous protection from moisture from the ground or through the supporting structure.

DPMs should be properly lapped in accordance with Chapter 5.1 Substructure and ground-bearing floors.

In-situ concrete:

Dampness from the ground and supporting structure should be prevented from reaching the floor by using linked DPMs and DPCs to provide continuous protection.

Where there is a risk of sulfate attack, in-situ or oversite concrete should be protected with polyethylene sheet that is a minimum:

- 1,200 gauge (0.3mm), or
- 1,000 gauge (0.25mm) if assessed in accordance with Technical Requirement R3.

Precast concrete:

Additional damp proofing may not be necessary where:

- the underfloor void is ventilated in accordance with CP 102, and DPCs are provided under bearings of precast floors
- ground below the floor is effectively drained, if excavated below the level of the surrounding ground.

Where proprietary floor systems are used, adequate moisture-resistant membranes should be installed in accordance with the manufacturer's recommendations.

Vapour control layers may be necessary to protect floor finishes and, where used, should be positioned in accordance with the manufacturer's recommendations.

Timber ground floors:

Timber used for suspended ground floors should either have adequate natural durability or be preservative treated in accordance with Chapter 3.3 Timber preservation (natural solid timber), and the ground below the floor covered with:

- 50mm concrete or fine aggregate on a polyethylene membrane laid on 50mm sand blinding, or
- 100mm concrete.

5.2.10.2 Ventilation

Ventilation should be provided to precast and timber suspended floors. This is generally provided by ventilators on at least two opposite external walls, with air bricks properly ducted in accordance with Chapter 6.1 External masonry walls. Where this is not possible, suitable cross ventilation should be provided by a combination of openings and air ducts. Ventilation should not be obtained through a garage.

Sleeper walls and partitions should be constructed with sufficient openings to ensure adequate through ventilation. If necessary, pipe ducts should be incorporated in adjoining solid floors, separating walls or other obstructions. Where underfloor voids adjoin ground-bearing floors, ventilation ducts should be installed.

Void ventilation should be provided to whichever gives the greater opening area:

- 1,500mm² per metre run of external wall
- 500mm² per m² of floor area.

In the case of timber floors, ventilators should be spaced at no more than 2m centres and within 450mm of the edge of the floor.

A minimum ventilation void of 150mm should be provided below the underside of precast concrete and timber suspended floors. On shrinkable soil where heave could take place, a larger void is required to allow for movement according to the volume change potential:

- high volume change potential — 150mm (300mm total void)
- low volume change potential — 50mm (200mm total void).
- medium volume change potential — 100mm (250mm total void)

Where precast concrete floor planks are used over a DPM laid directly on fill on non-shrinkable soil, the fill should be inert and non-expansive, raised up to the underside of the floor slab and well compacted. Where this is carried out, a ventilated void below the floor is not necessary.

5.2.11 Floor finishes

Finishes to suspended ground floors shall be protected where necessary, against damp, condensation or spillage.

Guidance for suitable floor finishes is given in Chapter 9.3 Floor finishes. Care should be taken to prevent trapping any water spillage below timber floors.

Other floor decking should be assessed in accordance with Technical Requirement R3 and installed in accordance with manufacturers' recommendations.

5.2.12 Floor decking

Floor decking shall be suitable for the intended purpose and be correctly installed.

Acceptable installation details and materials used for decking are detailed in Clause 6.4.19.

5.2.13 Further information

- *BRE Report BR 262 Thermal insulation: avoiding risks. 3rd Edition*
- *BRE Report BR 211 Radon: Guidance on protective measures for new buildings (including supplementary advice for extensions, conversions and refurbishment projects). 2023 Edition*



Chapter 5.3



Drainage below ground

This chapter gives guidance on meeting the Technical Requirements for foul, surface water and groundwater drainage systems.

This chapter does not apply to the adoption of sewers under Section 104 agreement of the Water Industry Act 1991 or the Sewerage (Scotland) Act 1968. For information on standards required for adopted sewers, contact the local sewerage undertaker and other relevant authorities.

5.3.1	Compliance	02
5.3.2	Provision of information	03
5.3.3	Preliminary work	03
5.3.4	Foul and surface water disposal	03
5.3.5	Drainage system performance	04
5.3.6	Groundwater drainage	05
5.3.7	Design to avoid damage and blockages	05
5.3.8	Durability	09
5.3.9	Septic tanks and cesspools	10
5.3.10	Septic tank outputs	10
5.3.11	Surface water soakaways	13
5.3.12	Component requirements	16
5.3.13	Excavation	16
5.3.14	Protection of pipework	17
5.3.15	Laying pipework	18
5.3.16	Protection of work	19
5.3.17	Drainage under buildings	19
5.3.18	Testing	21
5.3.19	Further information	21



Figure reference table

Figure Reference Table 5.3

Fig No	Title/Description	Clause	Page
Figure 1	Interceptor requirement when connecting surface water drain into a combined sewer	5.3.4.4	4
Figure 2	Access fitting	5.3.7.5	6
Figure 3	Inspection chamber	5.3.7.5	6
Figure 4	Manhole	5.3.7.5	6
Figure 5	Acceptable connection — rectangular manhole	5.3.7.5	7
Figure 6	Acceptable connection — proprietary manhole	5.3.7.5	7
Figure 7	Traditional benching	5.3.7.5	8
Figure 8	Pipe protection in close proximity to foundation	5.3.8.1	9
Figure 9	Pipe protection within influence zone of the foundation	5.3.8.1	9
Figure 10	Cross section of a typical underdrain	5.3.10.5	13
Figure 11	Typical cross section of a small surface water soakaway	5.3.11.2	14
Figure 12	Pipe laid in clearance hole with lintel over	5.3.14.1	17
Figure 13	Pipe bedded in walls	5.3.14.1	17
Figure 14	Pipe protection in soft landscaped area	5.3.14.2	17
Figure 15	Movement joint detail in concrete cased pipes	5.3.14.3	18
Figure 16	Pipe bedding construction types 1 and 3 to EN 1610	5.3.15.1	18
Figure 17	Hand compaction directly above pipe crown	5.3.15.2	19
Figure 18	Machine compaction to complete trench backfill	5.3.15.2	19
Figure 19	Protection of backfilled drainage trenches from construction work	5.3.16	19

Definitions for this chapter

For the purposes of this chapter, the following definitions apply:

Access point	Provision to access a sewer or drain for maintenance or inspection; includes any manhole, inspection chamber or rodding eye.
Curtilage	The area of land around a building, or group of buildings, which is for the private use of the occupants of the buildings.
Freeboard	The distance between the design water level and the top of a structure, provided as a precautionary safety measure against early system failure.
Gully	Assembly to receive water for discharge into a drainage system.
Infiltration system	A systems that is specifically designed to promote infiltration of surface water or treated effluent into the ground. There are many different types of drainage components which can be used to facilitate infiltration. Some of these include soakaways, infiltration trenches, infiltration basins and drainage fields for use in wastewater treatment.
Inspection chamber	Structure with a removable cover constructed on a drain or sewer that permits the introduction of cleaning and inspection equipment from surface level, but does not provide access for personnel.
Local authority	Includes an authority acting in any relevant capacity, such as a local planning authority (LPA), lead local flood authority (LLFA) or SuDS approval body (SAB).
Manhole	Structure with a removable cover constructed on a drain or sewer to permit entry by personnel.
Manhole top	Upper part of a manhole or inspection chamber consisting of a frame and cover and/or grating.
Private drain	Used for the drainage of one building or any buildings or yards appurtenant to buildings within the same curtilage.
Public sewer	A sewer for the time being vested in a water company in its capacity as sewerage undertaker.
Rising main	A sewer through which foul sewage and/or surface water is pumped.
Satisfactory outfall or effective discharge point	Point of discharge which has been specifically designed to discharge the foul sewage or surface water and for which there is a legal right to discharge. This can be another sewer or a watercourse (if there is a legal right to discharge) or an area of land or another infiltration drainage component.
Septic tank	A form of wastewater treatment plant; refers to both traditional in-situ constructed septic tanks as well as prefabricated septic tanks (or small wastewater treatment systems for up to 50 PT) conforming to BS EN 12566.

5.3.1 Compliance

Also see: Chapter 2.1

Drainage systems shall comply with the Technical Requirements.

Below ground drainage that complies with the guidance in this chapter will generally be acceptable.

All drainage schemes require the approval of the building control authority. Local sewerage undertakers may impose additional requirements and restrictions. Both should be consulted early, especially where the drainage system is to be adopted under a Section 104 agreement of the Water Industry Act 1991 or Sewerage (Scotland) Act 1968. The system may need to be inspected and tested by the sewerage undertaker, as well as by the local authority, building control authority and NHBC.

Satisfactory outfall disposal is essential where a septic tank or equivalent sewage treatment plant is installed. In England and Wales, Environment Agency consent may be required to discharge effluent from a septic tank or equivalent sewage treatment plant. In Northern Ireland, the Northern Ireland Environment Agency (NIEA) should approve proposals; in Scotland, the local authority and, where appropriate, the river purification authority should approve proposals.

Ground conditions may preclude the use of septic tanks or equivalent sewage treatment plant in some locations. In all cases, NHBC will require evidence of a satisfactory percolation test where an infiltration drainage system is being installed.

For surface water discharge into a watercourse, the permission of the Environment Agency is required in England and Wales. A 'consent to discharge' is required from the NIEA. In Scotland, the local authority and, where appropriate, the river purification authorities should be consulted.

In all cases:

- relevant local authorities should be consulted and appropriate permissions sought before sitework begins
- NHBC will require evidence of a satisfactory percolation test where a septic tank or equivalent sewage treatment plant is being installed.

Table 1: Guide to relevant authority

	Septic tank discharge	Surface water discharge into a watercourse
England and Wales	Environment Agency DEFRA	
Northern Ireland	Northern Ireland Environment Agency	
Scotland	Local authority River purification authority	Local authority River purification authority Scottish Environmental Protection Agency

5.3.2 Provision of information

Designs and specifications shall be produced in a clearly understandable format, include all relevant information and be distributed to all appropriate personnel.

Design and specification information should be issued to site supervisors, relevant specialist subcontractors and suppliers, and include the following information:

- proposed drain layout
- invert levels and locations of existing sewers
- junctions
- ground floor levels of homes
- external finished levels
- inspection and access points
- method of disposal of both foul and surface water
- position of any septic tank or cesspool in relation to adjacent buildings
- results of percolation tests where treated effluent disposal is through field drains or surface water through soakaways
- length of field drains and their layout (including details of trench width as this is critical to the functioning of the system)
- depth of field drains
- details of drains or sewers intended for adoption
- details of soakaways (including size or volume and surrounding details).

5.3.3 Preliminary work

Drainage systems shall be checked on site to ensure that the design can be achieved.

Check that the following are as specified in the design:

- invert levels and locations of existing sewers
- ground floor levels of homes
- external finished levels.

Percolation tests should be verified where treated effluent disposal is through field drains. The length of any field drains specified in the design should be accommodated within the site boundaries.

5.3.4 Foul and surface water disposal

Also see: BS EN 752, Clause 5.3.11 and BRE Digest 365

Drainage systems shall be designed in accordance with relevant codes and standards to convey foul effluents and surface water satisfactorily to an appropriate outfall. Issues to be taken into account include:

- 1) connections to sewers
- 2) connections to surface water disposal systems
- 3) rights of connection to disposal systems
- 4) compatibility with other systems
- 5) capacity of private sewers
- 6) treatment plants for more than one home.

5.3.4.1 Connections to sewers

Connections to public sewers require the agreement of the responsible authority, which should be consulted regarding the type and position of the connection.

Connections to private sewers require the agreement of the owners of the sewer. This should be obtained as part of the design process. Where the private sewer subsequently discharges into a public sewer, the local sewerage undertaker should be notified of the proposal.

5.3.4.2 Connections to surface water disposal systems

Surface water drainage is generally required to be separated from foul water drainage. Where permitted, surface water may be discharged into the main public surface water drains or directly into natural watercourses, ponds or soakaways, as appropriate. Surface water should not discharge to:

- septic tanks
- cesspools
- separate foul sewers.

For large or complicated homes, the volume of surface water to be disposed should be calculated in accordance with BS EN 12056-3.

5.3.4.3 Rights of connection to disposal systems

A legal right must exist when connecting drains to an outfall.

5.3.4.4 Compatibility with other systems

The drainage system should be compatible with the main sewerage system:

- with separate systems for foul water and surface water
- with separate systems where foul water is connected to the main sewer, while surface water disposal is by soakaways or other suitable means, or
- as a combined system.

Where the sewerage undertaker permits surface water drains to be connected to a foul water system:

- an interceptor should be installed on the surface water side of the foul sewer junction, or
- trapped gullies should be used.

Where groundwater drains are connected to surface water drains, there should be a silt trap on the groundwater side of the junction.

5.3.4.5 Capacity of private sewers

Private drainage systems should be:

- in accordance with BS EN 752
- sufficient to cope with the intended capacity.

Where an existing private drainage system is to be extended, or where the capacity is to be increased, sufficient investigation, measurement and calculation should be undertaken to ensure that all parts of the private system are of adequate capacity.

5.3.4.6 Treatment plants for more than one home

Small sewage treatment works for more than one home should be designed in accordance with BS EN 12566.

Discharge from the waste water treatment plant should be:

- sited at least 10m away from watercourses and homes
- designed by a suitably qualified engineer.

Figure 1: Interceptor requirement when connecting surface water drain into a combined sewer

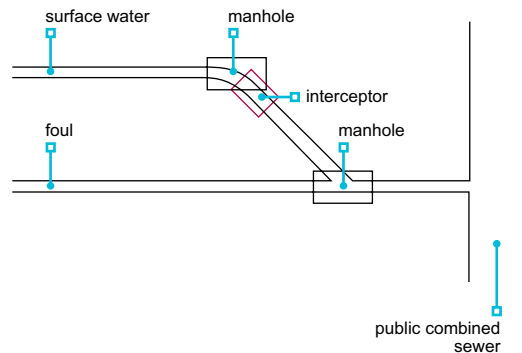

5.3.5 Drainage system performance

Also see: Chapters 4.1, 8.1, BRE Report 211 and BRE Report 212

Drainage shall be suitably located and prevent health hazards. Issues to be taken into account include:

- 1) ventilation of drainage systems
- 2) prevention of gases entering the home
- 3) siting of septic tanks and cesspools
- 4) pumped systems.

5.3.5.1 Ventilation of drainage systems

Ventilation of drains is normally achieved by ventilating discharge stacks.

Air admittance valves which comply with Technical Requirement R3 may be used in some homes to prevent trap seal siphonage. An open vent is generally required at the head of common drainage systems, and where the discharge pipe is the only vent for a septic tank or cesspool.

5.3.5.2 Prevention of gases entering the home

Where special precautions are necessary (eg sealing drains where they enter the building) to reduce the entry of gases such as radon or landfill gas, such precautions should be acceptable to NHBC.

5.3.5.3 Siting of septic tanks and cesspools

Septic tanks and cesspools should be:

- a minimum of 7m from homes
- a maximum of 30m from vehicular access to permit emptying.

In Scotland, a minimum distance of 5m from homes and boundaries is acceptable for septic tanks.

5.3.5.4 Pumped systems

Where a gravity system is not possible, pumped systems may have to be used and should be designed in accordance with BS EN 752 and BS 6297. The installation should include:

- a holding tank of sufficient volume to contain 24 hours of domestic effluent based on 120L/150L per head per day
- a suitable warning system providing visual and/or audible signals to indicate malfunction
- suitable equipment housing.

5.3.6 Groundwater drainage

Groundwater drainage shall convey excess groundwater to a suitable outfall. Issues to be taken into account include:

- 1) layout of pipes
- 2) pipe construction.

5.3.6.1 Layout of pipes

Where groundwater drainage is required, depending on the site contours and ground conditions, it may be designed as:

- a natural system
- a herringbone system
- a grid system
- a fan-shaped system
- a moat system.

5.3.6.2 Pipe construction

Pipe perforations should be holes or slots to suit the nature of the ground.

Groundwater drain systems connected to foul, surface water or combined drains should discharge into the drain through a catchpit. Where suitable, groundwater drainage may discharge into a soakaway, preferably through a catchpit or into a watercourse.

5.3.7 Design to avoid damage and blockages

Also see: Chapter 4.2, BS EN 476, BS EN 13598-1 and 2 and Sfa-7

Drainage systems shall minimise the risk of damage and blockage. Issues to be taken into account include:

- 1) ground stability
- 2) pipe runs
- 3) pipe sizes
- 4) gradients
- 5) access and connections
- 6) drainage covers and gully grids
- 7) groundwater
- 8) flooding.

5.3.7.1 Ground stability

Proper allowance should be made for ground movement.

Pipes should have flexible joints and additional precautions taken to prevent leakage where required. Where ground movement could be significant, for example in made-up ground or clay soils, the following issues should be taken into account:

- the use of flexible pipes and flexible joints
- design gradients that are steeper than the minimum requirements for flow rate and pipe size
- a support system designed by an engineer in accordance with Technical Requirement R5
- conditions where ground movement is likely to adversely affect the drain.

In non-uniform or saturated soils where movement at the trench bottom can be expected, soft spots should be removed and replaced with suitable material. Immediately after excavation, the protective blinding should be placed in the trench bottom.

5.3.7.2 Pipe runs

Pipe runs should be designed to maintain a self-cleansing velocity (0.7m/s). They should be as straight as practicable with minimal changes of direction. Bends should only occur in, or next to, inspection chambers and manhole covers. Curves should be slight so that blocked pipes can be cleared.

5.3.7.3 Pipe sizes

Pipe sizes should be designed for the maximum peak load in accordance with BS EN 752.

Groundwater drains and soakaways should be designed with sufficient capacity for normal weather conditions.

5.3.7.4 Gradients

Design gradients should:

- be as even as practicable
- where flows are less than 1.0L/second, gradients for 100mm diameter pipes should not be flatter than 1:40
- where peak flows exceed 1.0L/second, the gradients in Table 2 may be used.

Table 2: Minimum gradients

Pipe diameter (mm)	Minimum gradient
100	1:80
150	1:150

Where peak flows are greater than 1.0L/second, 100mm pipes should serve a minimum of one WC and 150mm pipes should serve a minimum of five.

5.3.7.5 Access and connections

To ensure that every length of drain can be rodded, the design should include appropriately located access points, such as:

- rodding points
- access fittings
- inspection chambers
- manholes.

Figure 2: Access fitting

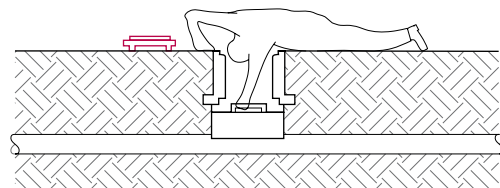

Figure 3: Inspection chamber

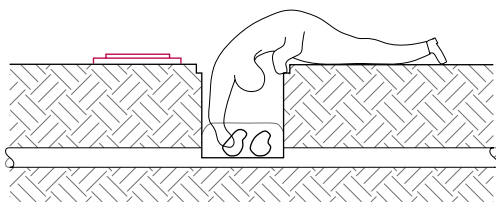
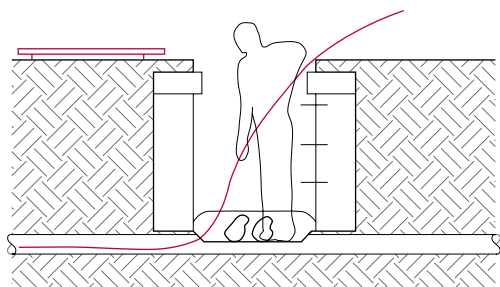

Figure 4: Manhole



All access points should be located as shown in the design information and should be accessible for rodding and cleaning.

Inspection chambers and manholes should be of sufficient size for the depth of invert:

- not cross boundaries or kerb lines
- the invert depth for the fitting or chamber should not exceeded those given in Table 3.

Table 3: Minimum dimensions for access fittings and inspection chambers

Type		Depth to invert from cover level (m)	Minimum internal sizes		Clear openings	
			Length x width (mm x mm)	Circular (mm)	Length x width (mm x mm)	Circular (mm)
Rodding point			As drain but min. 100			Same size as pipework
Small access fitting	150 dia. 150 x 100	0.6 or less, except where situated in a chamber	150 x 100	150	150 x 100	Same size as access fitting
Large access fitting	225 x 100		225 x 100	225	225 x 100	Same size as access fitting
Shallow inspection chamber		0.6 or less 1.2 or less	225 x 100 450 x 450	190 ⁽¹⁾ 300 ⁽³⁾	– Min. 430 x 430	190 310
Deep inspection chamber		Greater than 1.2	450 x 450	300 ⁽⁴⁾ - 450	Max. 300 x 300 ⁽²⁾	Access restricted to max. 350 ⁽²⁾

Notes

1. Drains up to 150mm.
2. A larger cover may be used in conjunction with restricted access. The size is restricted for health and safety reasons to deter entry.
3. Minimum 300mm diameter inspection chamber complying with BS EN 13598-1 or -2.
4. Minimum 300mm diameter inspection chamber complying with BS EN 13598-2 may be used up to a depth of 2m.

Table 4: Minimum dimension for manholes

Type	Size of largest pipe (DN) (mm)	Minimum internal dimensions ⁽¹⁾		Min. clear opening size ⁽¹⁾	
		Rectangular length and width (mm)	Circular diameter (mm)	Rectangular length and width (mm)	Circular diameter (mm)
Manhole up to 1.5m deep to soffit	Equal to or less than 150	750 x 675 ⁽⁷⁾	1,000 ⁽⁷⁾	750 x 675 ⁽²⁾ 1,200 x 675 ⁽²⁾	NA ⁽³⁾
	225	1,200 x 675	1,200		
	300	1,200 x 750	1,200		
	Greater than 300	1,800 x (DN+450)	The larger of 1,800 or (DN+450)		
Manhole greater than 1.5m deep to soffit	Equal to or less than 225	1,200 x 1,000	1,200	600 x 600	600
	300	1,200 x 1,075	1,200		
	375-450	1,350 x 1,225	1,350		
	Greater than 450	1,800 x (DN+775)	The larger of 1,800 or (DN+775)		
Manhole shaft ⁽⁴⁾ greater than 3.0m deep to soffit pipe	Steps ⁽⁵⁾	1,050 x 800	1,050	600 x 600	600
	Winch ⁽⁶⁾	900 x 800	900	600 x 600	600
	Ladder ⁽⁵⁾	1,200 x 800	1,200		

Notes

1. Larger sizes may be required for manholes on bends or where there are junctions.
2. May be reduced to 600mm x 600mm where required by highway loading restrictions and subject to a safe system of work being specified.
3. Not applicable due to working space needed.
4. Minimum height of chamber in shafted manhole 2m from benching to underside of reducing slab.
5. Minimum clear space between ladder or steps and the opposite face of the shaft should be approximately 900mm.
6. Winch only; no steps or ladders, permanent or removable.
7. The minimum size of any manhole serving a sewer ie, any drain serving more than one home, should be 1,200mm x 675mm rectangular or 1,200mm diameter.
8. Tables 3 and 4 have been reproduced from Tables 11 and 12 of Approved Document H by permission of HMSO.

Inspection chambers and manholes may be one of the following types:

- open, half-round section channel with suitable benching
- closed access, where covers have to be removed to gain access to the pipe.

Side branches to inspection chambers and manholes should discharge into the main channel no higher than half pipe level. Connections should be made obliquely in the direction of flow.

Figure 5: Acceptable connection — rectangular manhole

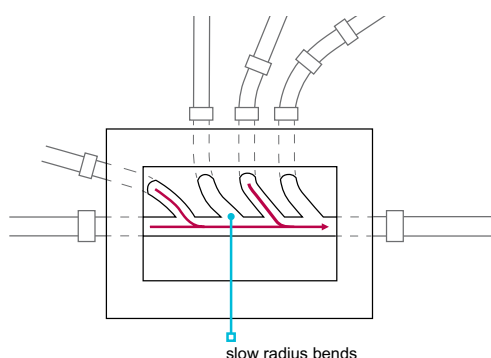
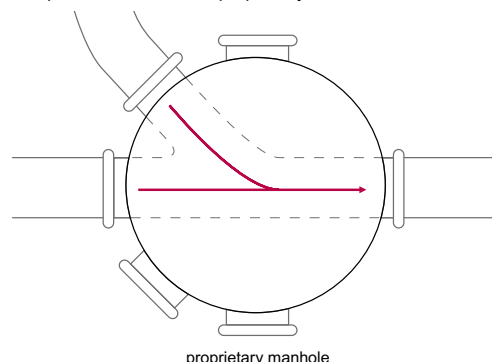

Figure 6: Acceptable connection — proprietary manhole



Traditional construction

The minimum specification for traditional manholes and inspection chambers is as follows:

Base	Minimum 100mm concrete
Walls	Brick, blockwork or concrete should be appropriate for the ground conditions 100mm minimum thickness is suitable for depths up to 0.9m where no vehicular traffic loads are encountered and there is no groundwater pressure Elsewhere, 200mm minimum thickness should be provided
Rendering	Where required, rendering should be applied to the external faces of the wall
Benching	Benching should be steel trowelled to provide: <ul style="list-style-type: none"> • a smooth finish • rounded corners • a fall of not less than 1:12

Figure 7: Traditional benching

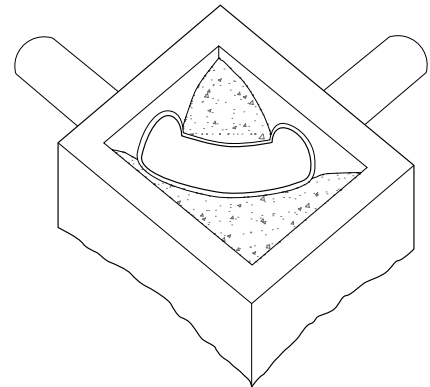

Clay bricks for manholes should comply with BS EN 771 and:

- be of low active soluble salt content
- have a minimum compressive strength of 48N/mm².

Engineering bricks are also suitable.

Concrete bricks for manholes should:

- comply with BS EN 771
- have a minimum crushing strength of 48N/mm² with a minimum cement content of 350kg/m³ for foul drainage.

Calcium silicate bricks should comprise strength class 20 or above for foul drainage situations.

Proprietary systems

Proprietary systems should be:

- in accordance with Technical Requirement R3
- installed in accordance with manufacturers' instructions.

Proprietary manholes should not be used at a depth greater than the manufacturer's instructions.

Adaptors, couplers and sealing rings should be:

- installed correctly and in accordance with the manufacturer's instructions
- treated using the lubricants and solvents specified.

5.3.7.6 Drainage covers and gully grids

Manhole covers and gully grids should be of the correct type for the proposed location in accordance with Tables 5 and 5a.

Manhole covers used within buildings should be airtight and mechanically secured. Covers used for septic tanks, cesspits and settlement tanks should be lockable.

Manholes should be constructed or installed at the correct level so that the covers will align with the adjacent ground.

Gullies should be adequately:

- bedded
- set level
- square and kerbed.

Table 5: Type of covering and grid required for inspection and manhole covers and frames

Group 1	Areas which can only be used by pedestrians and cyclists
Group 2	Footways, pedestrian areas and comparable areas, car parks or car parking decks
Group 3	For gully tops installed in the area of kerbside channels of roads which when measured from the kerb edge, extend a maximum of 0.5m into the carriageway and a maximum of 0.2m into the footway
Group 4	Carriageways of roads, including pedestrian streets, hard shoulders and parking areas, and suitable for all types of road vehicles

Proprietary items, eg covers to plastic manholes, should be in accordance with manufacturers' recommendations.

Table 5a: Gully grids in carriageways

Grade B	For use in carriageways of roads with cars and slow-moving normal commercial vehicles
Grade A class 2	For use in carriageways of roads
Grade A class 1	For use in carriageways of roads (gully grids of permanent non-rock design)

5.3.7.7 Groundwater

Foul and surface water drainage systems should prevent the ingress of groundwater.

5.3.7.8 Flooding

Where there is a risk of flooding, the advice of the relevant river authority should be followed.

5.3.8 Durability

Also see: Chapters 3.1 and 6.1

Drainage systems shall be adequately durable and protected against damage. Issues to be taken into account include:

- | | |
|---------------------------|--|
| 1) loads from foundations | 3) loads from overlying fill and traffic |
| 2) bedding of pipes | 4) chemicals in ground and groundwater. |

5.3.8.1 Loads from foundations

Drains should be located so that foundation loads are not transmitted to pipes. Where drainage trenches are near foundations:

- foundation bottoms should be lower than adjacent trenches, or
- the drain should be re-routed to increase separation.

Where the bottom of a drainage trench is below foundation level, the trench should be filled with concrete to a suitable level.

Figure 8: Pipe protection in close proximity to foundation

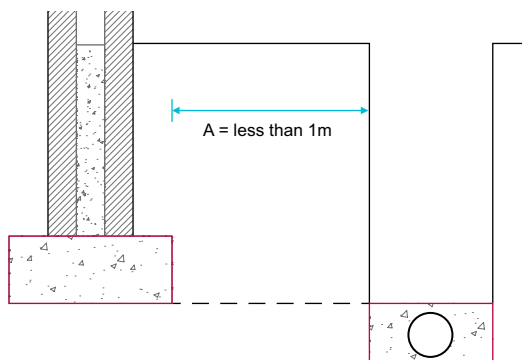
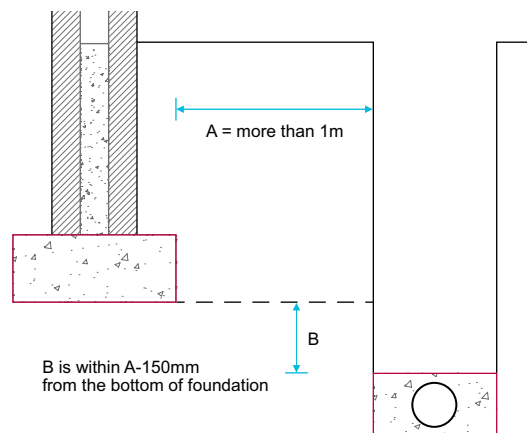

Figure 9: Pipe protection within influence zone of the foundation



5.3.8.2 Bedding of pipes

Bedding should be in accordance with Clause 5.3.15.

5.3.8.3 Loads from overlying fill and traffic

Special protection may be required where pipes are near the ground surface or where they could be damaged by the weight of backfill or traffic load from above.

For flexible pipes, and where greater safety is needed, the bedding class and grading of backfill should comply with BS EN 13242, BS EN 1610 and BS EN 752.

When using proprietary systems assessed in accordance with Technical Requirement R3, pipes should be supported accordingly.

5.3.8.4 Chemicals in ground and groundwater

Where the ground or groundwater contains sulfates, concrete and masonry work may require special precautions.

5.3.9 Septic tanks and cesspools

Septic tanks and cesspools shall be correctly installed and be suitable for their intended use. Issues to be taken into account include:

- | | |
|---------------------------|---|
| 1) capacity | 3) permeability of septic tanks and cesspools |
| 2) access and ventilation | 4) connections to septic tanks and cesspools. |

A septic tank is a form of treatment plant and requires a suitable outfall for treated effluent discharge, which is agreed with the relevant authority.

A cesspool is a tank which stores effluent and has to be emptied periodically.

5.3.9.1 Capacity

The capacity of the septic tank should be based on the number of people it will serve, using the formula: $C = 180P + 2,000$.

C = Capacity of tank in litres. Minimum 2,700L.

P = Design population/potential occupancy. Minimum four occupants.

Cesspools are required to be at least 18m³ capacity per two users (plus another 6.8m³ per each extra user). A 45-day holding capacity calculated at 150 litres/head/day should be provided.

5.3.9.2 Access and ventilation

Septic tanks and cesspools should:

- be covered and ventilated
- be provided with access points for inspection, emptying, de-sludging and cleaning
- have the access points with lockable covers and no dimension less than 600mm.

The inlet and outlet of a septic tank should be provided with access for inspection. The inlet of a cesspool should be provided with access for inspection. Cesspools should have no openings except the inlet, the vent and the inspection access.

5.3.9.3 Permeability of septic tanks and cesspools

Septic tanks and cesspools should be impermeable to their contents and to subsoil water. They should be constructed of brickwork, concrete, glass reinforced concrete, glass reinforced plastics or steel.

Brickwork should be of engineering bricks, laid in cement mortar at least 220mm thick. In-situ concrete should be at least 150mm thick.

5.3.9.4 Connections to septic tanks and cesspools

The entry flow velocity should be restricted to reduce disturbance in the tank. Where the drain into the septic tank is less than 150mm in diameter, it should have a gradient no steeper than 1:50 for at least 12m.

Rodding and cleaning facilities should be provided at the connection with the tank.

5.3.10 Septic tank outputs

Also see: BS 6297

Septic tanks shall have suitable drainage connections. Issues to be taken into account include:

- | | |
|-------------------------------|-----------------|
| 1) outfall | 4) field drains |
| 2) flow velocity | 5) underdrains. |
| 3) soakaways for septic tanks | |

5.3.10.1 Outfall

The designer should ensure at an early stage that consent for discharge will be given, or select an alternative method of drainage. Certain locations and ground conditions may preclude the use of proprietary septic tanks. Septic tank sewage systems should have:

- satisfactory outfall disposal
- placement that accounts for topography and ensures that water is drained away from the building.

Where a septic tank drainage system is to be installed, NHBC requires:

- evidence of a satisfactory percolation test
- copies of relevant consents and approvals before work commences.

5.3.10.2 Flow velocity

A dip pipe should be provided with:

- the top limb rising above scum level,
- the bottom limb extending about 450mm below top water level.

5.3.10.3 Soakaways for septic tanks

Soakaways in porous subsoils

A soakaway may be used where the outfall from a proprietary septic tank is to discharge to a porous subsoil at a level above that of the winter water table. Soakaway constructions generally consist of an excavation filled with brick bats or other large pieces of inert material, or unfilled but lined, eg with dry laid brickwork or precast concrete (porous or perforated) rings, from which the effluent may percolate into the surrounding ground. Proprietary septic tanks should be assessed in accordance with Technical Requirement R3.

Soakaways which are not filled should be covered by a slab incorporating an inspection cover.

The size of the soakaway should be determined as described in this chapter and the area of the bottom of the soakaway should equal the area of trench bottom in Chart 1.

Where the porous strata is overlaid by less permeable subsoil, a borehole may be permitted by the appropriate authority on obtaining a discharge consent.

Where soakaways are to be used, the use of a tertiary treatment unit may be required to minimise the amount of suspended solids in the treated wastewater, and the use of a grease trap to part cleanse kitchen wastewater, upstream of a packaged treatment plant, may also be necessary to minimise the risk of fat clogging up the soakaway system.

Where a geotextile wrapped cellular soakaway is the desired outfall for a single unit treatment plant or a proprietary septic tank, it should be designed for the discharge from the treatment plant to flow via the silt trap chamber before entering the soakaway. The chamber should be regularly maintained (together with the treatment plant) to ensure suspended particles discharged into the soakaway is minimised.

Soakaways in less porous subsoils

In less porous subsoils, a sub-surface irrigation system may be used, which should be designed:

- using approved means to determine the percolation rate
- according to the area of sub-surface drainage from which the length of land drain can be found, determined by the following procedure.

Table 6: Percolation test procedure for septic tanks

Step 1	Excavate a hole 300mm square and 250mm deep below the proposed invert level of the land drain
Step 2	Fill with water to depth of 250mm. As an aid, mark a stick 250mm from one end, place in the hole and fill to the mark. Allow the water to drain away overnight
Step 3	Refill to a depth of at least 250mm and note the time taken (in seconds) to drain away completely
Step 4	Repeat the exercise two more times and calculate the average of the three results, as follows: $\text{percolation value (s)} = \frac{\text{time to drain away (seconds)}}{\text{depth of water (mm)}}$

The results of the percolation test should be used in accordance with Table 6a to determine a suitable method of drainage.

Table 6a: Suitable methods of drainage

Percolation value (s)	Suitability for less porous subsoils
Up to 100	Chart 1 to determine the field drain trench area Chart 2 to determine the pipe length to provide this area
100 to 140	As above, but underdrains are also necessary
Over 140	The soil is unsuitable for field drains

Table 7: Capacity based on potential occupancy

Number of persons/bed spaces	Minimum capacity (litres)
<4	2,700
4	2,720
5	2,900
6	3,080
7	3,260
8	3,440
9	3,620
10	3,800

Chart 1: Field drains trench area

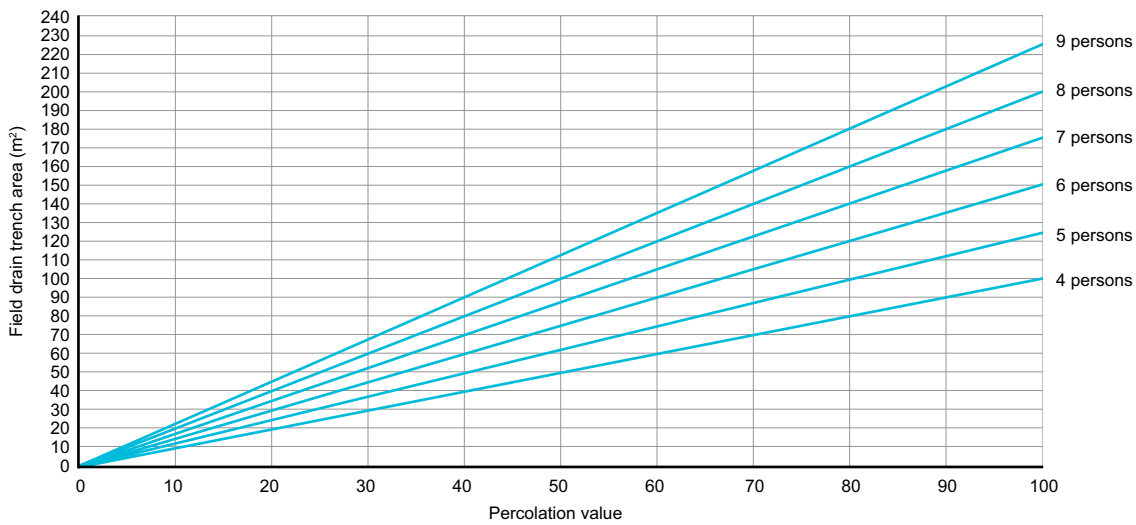
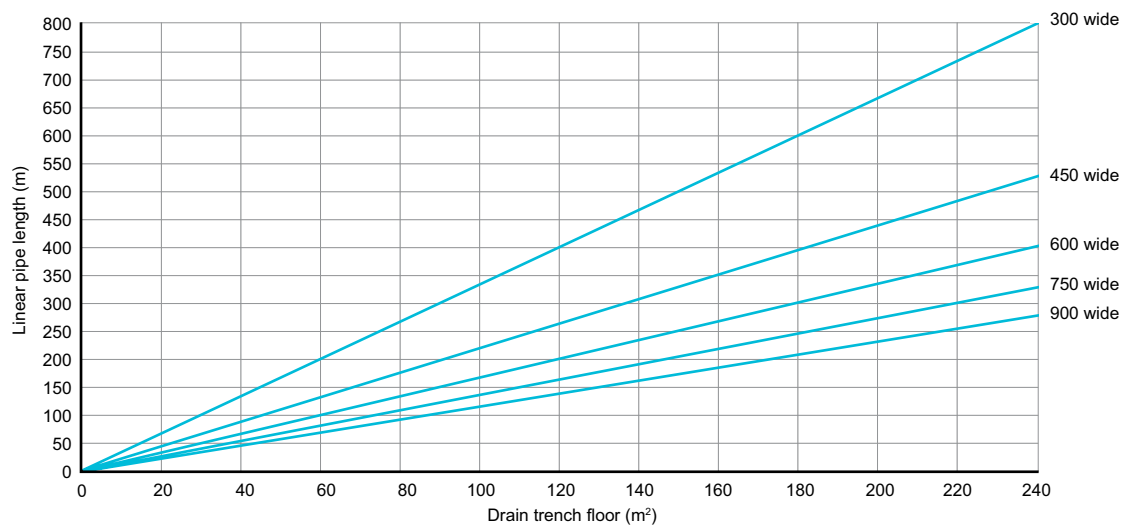

Chart 2: Field pipe length



5.3.10.4 Field drains

Field drains should be:

- sited according to topography, ensuring that water is drained away from the building
- formed with perforated pipe, laid at least 500mm below the surface
- laid in trenches with a uniform gradient less than 1:200, with undisturbed ground 2m wide between trenches and at least 8m from any building and 10m from any watercourse
- laid on a 150mm bed of clinker, clean gravel or broken stone (20mm–50mm grade) and trenches filled to a level 50mm above the pipe and covered with strips of plastic material to prevent entry of silt
- backfilled with as-dug material.

Where the level of the water table is expected to rise in the winter months to within 1m of the field drain invert, it is not acceptable to use subsurface irrigation.

5.3.10.5 Underdrains

Where underdrains are necessary, drainage trenches should be constructed a minimum of 600mm deeper than the pipe level specified in the design.

The lower part of the drainage trenches should be filled with pea gravel. A second system of drainage pipes should be laid on the bottom of the trenches to convey surplus drainage to an outfall in a surface ditch or watercourse.

Figure 10: Cross section of a typical underdrain

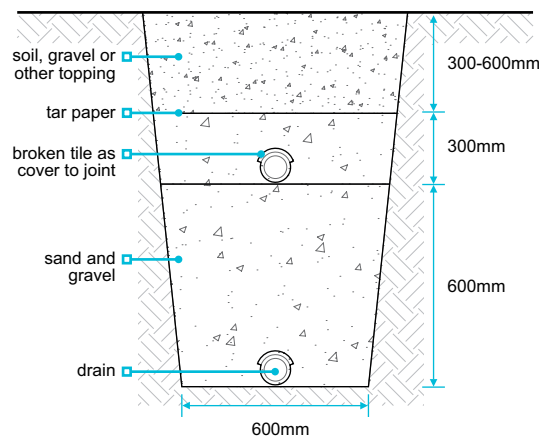

5.3.11 Surface water soakaways

Also see: BRE Digest 365

Soakaway drainage shall be sited and constructed to provide adequate short-term storage for surface water and adequate percolation into the surrounding ground. Issues to be taken into account include:

- 1) soakaway location
- 2) soakaway design.

5.3.11.1 Soakaway location

Soakaways should be:

- built on land lower than, or sloping away from, buildings
- sited at least 5m from the foundations of a building
- sited to take account of topography, ensuring that water is drained away from the building
- in soil of low permeability, only provided where no alternative system is available.

5.3.11.2 Soakaway design

NHBC will require a percolation test for a soakaway, especially where there is:

- doubt about the ground
- a large quantity of run-off into the soakaway which may swamp the ground.

Where the ground is free draining and granular, a test may not be necessary.

In soil, chalk and fill material subject to modification or instability, the advice of a specialist geotechnologist should be sought regarding the siting and suitability of soakaways.

Large soakaways

Large soakaways consist of a pit lined with dry jointed or honeycomb brickwork.

Alternatively, precast perforated concrete rings or segments may be laid dry and surrounded with granular material.

Large soakaways should be designed in accordance with BRE Digest 365, and the volume calculated to ensure suitable capacity, including checking the appropriate time to empty half the storage volume.

Small soakaways

Small soakaways are holes filled with granular material, eg broken brick, crushed rock or gravel, with particle size 10mm to 150mm.

PVC sheet or concrete blinding should be laid over the fill to prevent topsoil being washed down into the soakaway.

Percolation test procedure for small surface water soakaway

The rate at which water will disperse into the ground depends on the permeability of the ground, which varies with soil type. The percolation test provides an assessment of how the ground drains.

The following test procedure and design approach may be adopted where the soakaway is for a single dwelling development with a total drained area of less than 100m².

As the test hole can be used as part of a soakaway, it should be:

- dug in a place that could be used as a soakaway
- to the same depth as the proposed drain.
- at least 5m from the foundations of a building

Table 8: Percolation test procedure for small surface water soakaways

Step 1	Bore a hole 150mm in diameter with an auger, to a depth of one metre
Step 2	Fill with water to depth of 300mm. As an aid, mark a stick 300mm from one end, place in the hole and fill up to the mark. It takes approximately 5.5 litres to fill a volume of this size
Step 3	Observe the time taken in minutes for the water to soak away
Step 4	Where possible, the test should be repeated and the average time used
Step 5	A second group of tests are carried out after the hole has been bored out to a depth of two metres, still using a 300mm depth of water
Step 6	Where the soil appears to become more permeable with depth, it may be useful to deepen and retest the bore in one-metre stages

Design of small soakaway

The relationship between the diameter or effective depth required for a soakaway to suit a given collection area, eg roof or paved surface, and the average time (T) resulting from the test, is shown in Chart 3.

The diameter and effective depth below invert level are assumed to be the same dimension (D) — see Figure 11.

Example

Test time (T) = 900 minutes

Plan area to drain = 150m²

Figure 11: Typical cross section of a small surface water soakaway

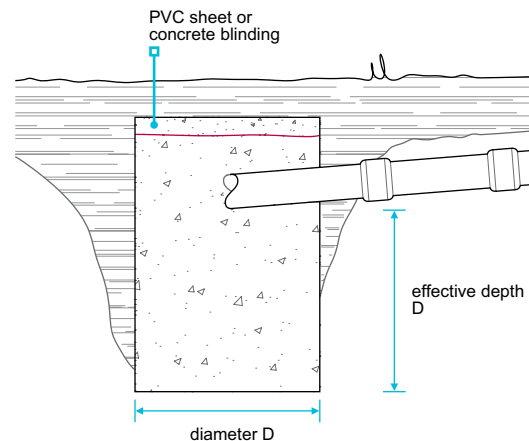
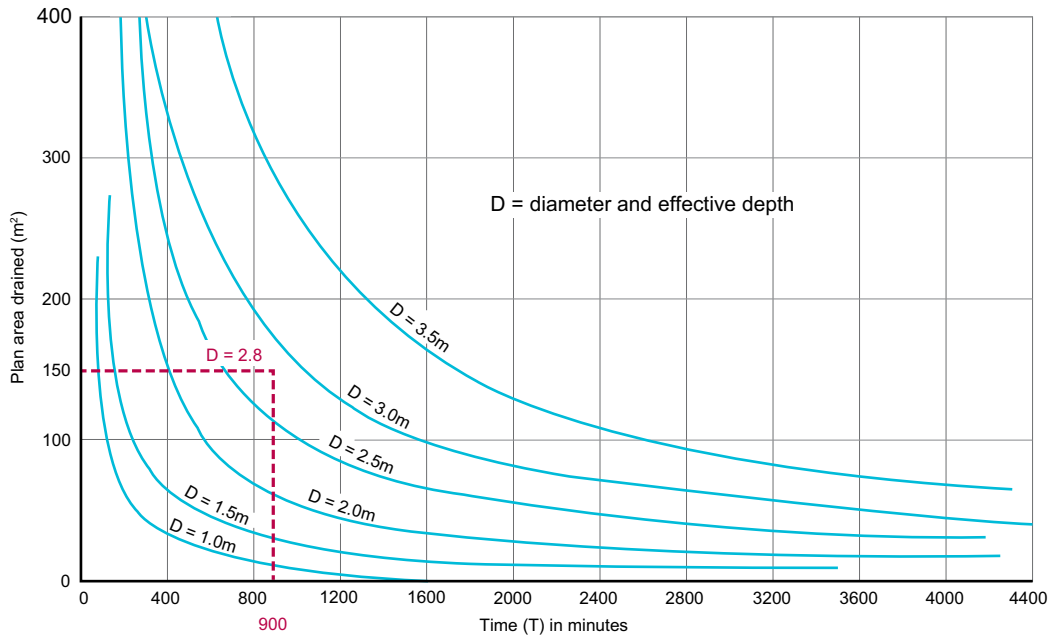

Chart 3: Graph for sizing small soakaways using 150mm diameter test hole

From the graph below, the diameter and effective depth of the soakaway (D) are both 2.8m.



Where the ground is of low permeability; dig separate soakaways to drain smaller but distinct parts, for example:

- one side of a roof to one soakaway
- the driveway or yard to a third soakaway.
- the other side to a second soakaway

Where the permeability of the ground increases with depth, tests in the deepened trial holes will give shorter percolation times. It may be more cost effective to build a smaller soakaway at a greater depth below the surface.

5.3.12 Component requirements

Drainage systems shall be constructed with materials that ensure satisfactory service over the life of the system.

Components in accordance with the following standards will generally be acceptable.

Table 9: British Standards and relevant codes of practice

BS 65	Specification for vitrified clay pipes, fittings and ducts, also flexible mechanical joints for use solely with surface water pipes and fittings
BS 437	Specification for cast iron drain pipes, fittings and their joints for socketed and socketless systems
BS 4660	Thermoplastics ancillary fittings of nominal sizes 110 and 160 for below ground gravity drainage and sewerage — specification
BS 4962	Specification for plastics pipes and fittings for use as subsoil field drains
BS 5911	Precast concrete pipes, fittings and ancillary products
BS EN 124	Gully tops and manhole tops for vehicular and pedestrian areas
BS EN 295	Vitrified clay pipe systems for drains and sewers
BS EN 476	General requirements for components used in drains and sewers
BS EN 588	Fibre-cement pipes for sewers and drains
BS EN 877	Cast iron pipes and fittings, their joints and accessories for the evacuation of water from buildings. Requirements, test methods and quality assurance
BS EN 1401-1	Plastics piping systems for non-pressure underground drainage and sewerage. Unplasticized poly(vinyl chloride) (PVC-U) — Specifications for pipes, fittings and the system
BS EN 1916	Concrete pipes and fittings, unreinforced, steel fibre and reinforced
BS EN 12566-1	Small wastewater treatment systems for up to 50 PT — Prefabricated septic tanks
BS EN 13101	Steps for underground man entry chambers. Requirements, marking, testing and evaluation of conformity
BS EN 13476	Plastic piping systems for non-pressure underground drainage and sewerage. Structured wall piping systems of unplasticized poly (vinyl chloride) (PVC-U), polypropylene (PP) and polyethylene (PE). Parts 1, 2 and 3
BS EN 13598-1	Plastics piping systems for non-pressure underground drainage and sewerage. Unplasticized poly (vinyl chloride) (PVC-U), polypropylene (PP) and polyethylene (PE). Specifications for ancillary fittings and shallow chambers
BS EN 13598-2	Plastics piping systems for non-pressure underground drainage and sewerage. Unplasticized poly (vinyl chloride) (PVC-U), polypropylene (PP) and polyethylene (PE) — Specifications for manholes and inspection chambers

5.3.13 Excavation

Excavations shall ensure that the invert levels and gradients required by the design are achieved. Issues to be taken into account include:

- | | |
|---------------------------|-----------------------|
| 1) setting out dimensions | 3) width of trenches. |
| 2) depth of trenches | |

5.3.13.1 Setting out dimensions

When setting out:

- discrepancies in dimensions, and ground conditions which require design modification, should be reported to the designer
- drain runs and depths should be set out from benchmarks previously checked and verified
- resulting variations should be recorded and distributed to all concerned.

5.3.13.2 Depth of trenches

Excavate to the depths specified in the design.

Where any trench is excavated lower than the designed bottom level, it should be refilled to the designed level.

Fill material should be:

- granular material, or
- concrete mix GEN1 or ST ½ (not for field drains).

Hard spots should be undercut and removed so that local stress points under pipes are avoided. Soft spots should be filled with suitable well-compacted material.

5.3.13.3 Width of trenches

Trenches should be as narrow as possible within working limits and allow a minimum 150mm working space on each side of the pipe.

5.3.14 Protection of pipework

Also see: Chapters 4.3 and 5.1

Drainage systems shall have pipework adequately protected against damage. Issues to be taken into account include:

- 1) pipes passing through substructure walls
- 2) pipework under finishes
- 3) movement joints.

5.3.14.1 Pipes passing through substructure walls

Where drains pass through structural elements, allowance should be made to accommodate movement.

Pipes passing through substructure walls should accommodate movement by:

- a 50mm clearance all round
- a sleeve, with 50mm clearance all round and suitably sealed, or
- bedded pipes, connected on both sides of the wall with flexible joints located as close as is feasible to the outside face of the wall but at a maximum of 150mm from the face of the wall.

Flexible joints should be made in accordance with the pipe manufacturer's recommendations.

Figure 12: Pipe laid in clearance hole with lintel over

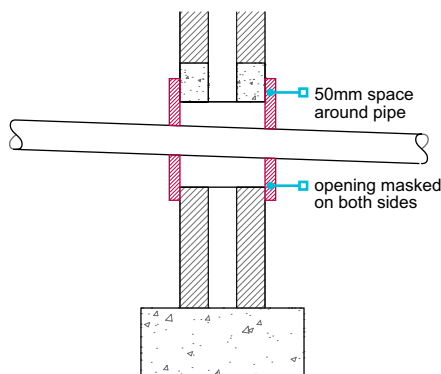
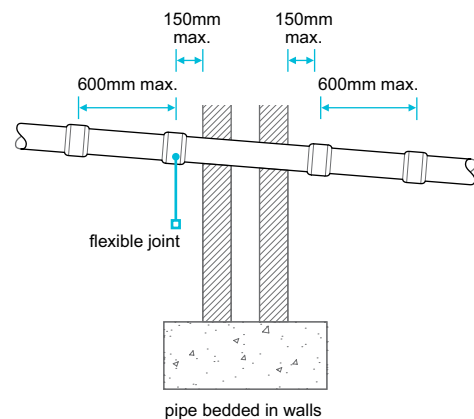

Figure 13: Pipe bedded in walls



5.3.14.2 Pipework under finishes

Where drains pass under roads and drives, the final compaction should be sufficient to prevent later settlement.

Table 10: Pipework protection in utility areas

Rigid pipes less than 1.2m below road surface	Should have: <ul style="list-style-type: none"> • where necessary, a minimum 100mm concrete encasement • movement joints formed with compressible board at each socket or sleeve joint face • flexible joints which remain flexible.
Flexible pipes less than 0.9m below road surface	Should be protected by concrete bridging slabs, or surrounded with reinforced concrete as appropriate
Garden areas	Where flexible pipes are not under a road and have less than 600mm cover, where necessary they should have: <ul style="list-style-type: none"> • concrete paving slabs laid as bridging above the pipes • a minimum 75mm of granular material between the top of the pipe and underside of the slabs.

Figure 14: Pipe protection in soft landscaped area

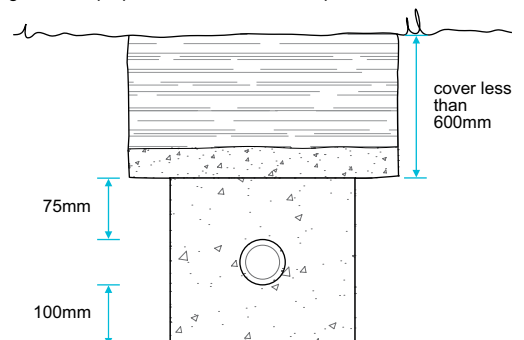

5.3.14.3 Movement joints

Where rigid pipes are to be encased in concrete, movement joints should be:

- provided around the spigot next to the socket either at 5m maximum intervals or at each joint
- 13mm thick compressible board.

Figure 15: Movement joint detail in concrete cased pipes

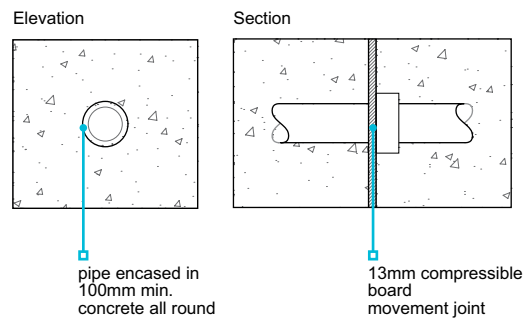

5.3.15 Laying pipework

Pipework shall be laid to the designed lines and gradients. Issues to be taken into account include:

- 1) bedding
- 2) sidefill and backfill.

5.3.15.1 Bedding

Pipes should be firmly supported throughout their length and bedded as specified in the design to resist loads from overlying fill and traffic.

Where pipework is installed under a suspended floor and is supported on ground or fill where movement is likely to occur, additional provisions may be required (see Clause 5.3.8).

Bricks, blocks or other hard material should not be used as temporary supports to achieve the correct gradients, as they may create hard spots which can distort the completed pipe run.

Pipes should be either:

- bedded on granular material, minimum 100mm deep, or
- laid directly on the trench bottom, where the trench bottom can be accurately hand trimmed with a shovel but is not so soft that it puddles when walked on.

For 150mm diameter and 100mm diameter drains, a bed and surround granular material like pea gravel in accordance with Table 8 (to a thickness of 100mm all round the drain) will be acceptable for drains under gardens, paths and drives.

Proprietary systems should be assessed in accordance with Technical Requirement R3 and supported in accordance with the manufacturer's recommendations. Some proprietary systems permit a minimum of 50mm depth of bedding in certain circumstances.

Depressions should be formed where necessary in the trench bottom to accommodate pipe joints.

Pipe bedding, including the bedding material, should be in accordance with:

- BS EN 13242
- BS EN 1610
- BS EN 752.

Figure 16: Pipe bedding construction types 1 and 3 to EN 1610

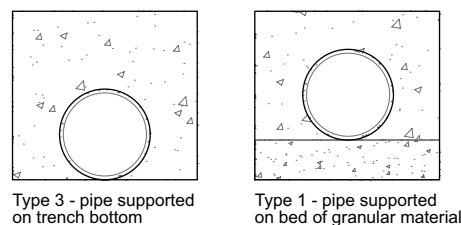

Bedding material and specification should be in accordance with Table 11. Backfill and bedding that includes recycled or secondary materials should conform to the appropriate regulatory requirements for waste, as defined in the Waste Framework Directive 2008.

Table 11: Bedding size

Nominal pipe size	Bedding material complying with BS EN 13242
110mm flexible pipes 100mm rigid pipes	4/10mm pipe bedding gravel
160mm flexible pipes 150mm rigid pipes	2/14mm pipe bedding gravel

5.3.15.2 Sidfill and backfill

Sidfill and backfill should be placed as soon as the pipes have been bedded, jointed and inspected.

Sidfill should be either granular material or selected backfill material from the trench excavation, free from:

- stones larger than 40mm
- clay lumps larger than 100mm
- timber
- frozen material
- vegetable matter.

Backfill should be well compacted and placed in layers no deeper than 300mm. Mechanical compacting should only be used when compacted backfill is over 450mm above the crown of the pipe.

Figure 17: Hand compaction directly above pipe crown

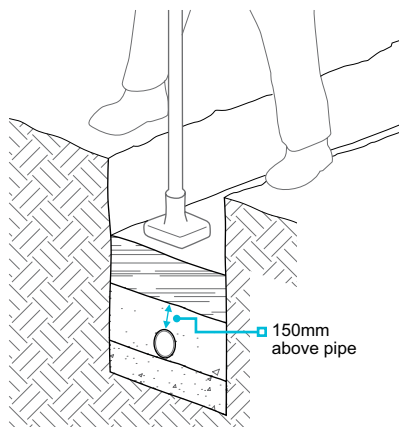
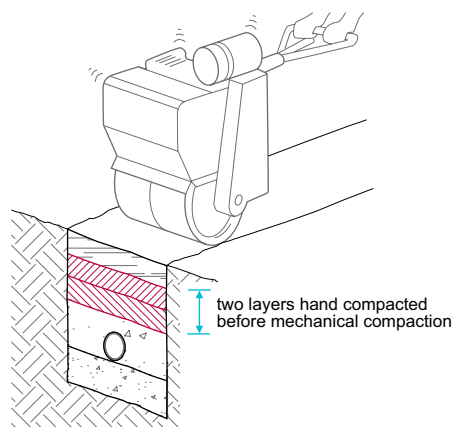

Figure 18: Machine compaction to complete trench backfill



5.3.16 Protection of work

Drainage systems shall be suitably protected from damage by construction work.

Damaged drainage will not be accepted, and it is recommended that:

- no heavy loading or underground work is permitted above, or near, unprotected drainage
- dumpers, trucks, fork lifts or other heavy vehicles are not driven along, or near, pipe runs.

Figure 19: Protection of backfilled drainage trenches from construction work

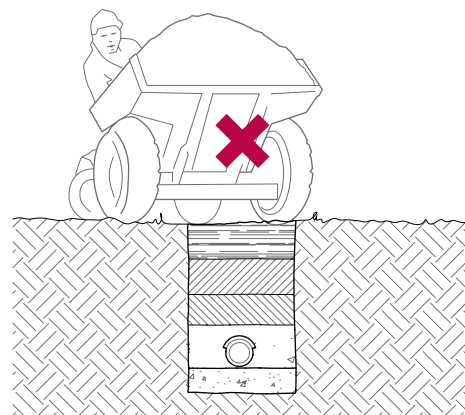

5.3.17 Drainage under buildings

Drainage system under buildings shall be suitably designed and supported to ensure an effective and satisfactory performance for the life of the building. Issues to be taken into account include:

- 1) ground supported pipework
- 2) suspended drainage
- 3) examples of site installations
- 4) drainage beneath specialist foundations.

Pipework support should take account of the ground conditions and ensure that the drainage is not adversely affected by ground movement.

Pipework under suspended floors should not be supported on ground or fill that is susceptible to movement without adequate provision being made to:

- maintain minimum design gradients
- protect against leakage.
- protect against backfall

See Clause 5.3.14 for Pipework passing through substructure walls.

5.3.17.1 Ground supported pipework

Where the ground is not at risk of settlement or heave, drainage can be installed in a trench with suitable bedding and backfill.

Where fill is used to support drainage on made-up ground at risk of settlement, it should be a maximum depth of 600mm, well graded, inert and without hazardous materials.

The fill should be placed and mechanically compacted in layers not exceeding 225mm in depth, to form a stable mass. Any fill in excess of 600mm which supports drainage should be designed by an engineer to avoid settlement. Drainage pipes should be bedded into the compacted fill.

In ground at risk of settlement, drainage can be laid in the normal manner, but at a steeper gradient than recommended minimums, to allow for any settlement and avoid backfalls. Easy or rest bend connections to above ground drainage can be made with proprietary settlement pipe sockets, which provide for more movement than a standard pipe socket connection. Alternatively, drainage can be suspended.

5.3.17.2 Suspended drainage

In ground at risk of significant heave or settlement, a suspended drainage installation should be used.

Pipe supports should be adjustable to achieve a consistent gradient and rigid enough for rodding without causing dislodgement. Support brackets should be suitable for an underfloor environment. Lightly pre-galvanised thin strapping can easily rust and collapse, so it should not be used. Purpose-made stainless steel or suitably galvanised brackets should be used.

Where suspended horizontal drainage is used, it should be supported as per the manufacturer's recommendations, typically 900mm to 1,000mm centres for 110mm nominal diameter pipes and at every socket or joint. Long pipe runs (typically 5m or greater) should be designed to accommodate thermal movement.

5.3.17.3 Examples of site installations

Ground supported drainage are often seen bedded, backfilled and strapped to suspended floors as shown in photos 1 and 2. In many cases, the strappings are flexible lightly galvanised type, fixed to floor beams on one side of the drain. These are unacceptable as ground settlement here can cause the straps to pull the drain out of alignment. Equally, such strappings are less able to resist movement of the pipework during rodding, thereby increasing the risk of disconnection and leakage.

Where a fully suspended design is adopted, rigid proprietary brackets which clamp around the drainage pipe and have adjustable threaded support rods should be used eg as shown in photos 3-5. Some brackets clamp to concrete beams, and others are built into the floor structure. In each case, it is necessary to ensure the pipes are fully supported at the sockets and at horizontal centres in accordance with the pipe manufacturer's instructions.

Photo 1



Photo 2



Photo 3



Photo 4



Photo 5



5.3.17.4 Drainage beneath specialist foundations

Where drains are located beneath raft foundations or where ground movement is likely, the design of the pipework and support system should be carried out by a suitably qualified engineer in accordance with Technical Requirement R5.

5.3.18 Testing

All foul and surface water drainage systems shall be adequately watertight, and tested where appropriate.

Inspection and testing should be arranged when required by:

- the local authority
- the sewerage undertaker
- NHBC.

Before backfilling, visual inspections are required and the builder is advised to test. When the home is handed over, the system must be in full working order and free from obstruction.

5.3.19 Further information

- *BS 6297 — Code of practice for the design and installation of drainage fields for use in wastewater treatment*
- *BS EN 752 — Drains and sewer systems under buildings. Sewer system management*
- *BRE Report 211 — Radon. Guidance on protective measures for new buildings*
- *BRE Report 212 — Construction of new buildings on gas-contaminated land*
- *BRE Digest 365 — Soakaway design. 2016 Edition*
- *SFA 7 — Sewer for Adoption. A design and construction guide for developers. 7th Edition*

Waterproofing of basements and other below ground structures

This chapter gives guidance on meeting the Technical Requirements for the waterproofing of basements and other structures below, or near to, ground level.

5.4.1	Compliance	03
5.4.2	Provision of information	03
5.4.3	Waterproofing	04
5.4.4	Ground conditions	04
5.4.5	Structural stability	05
5.4.6	Design considerations	06
5.4.7	Waterproofing systems	07
5.4.8	Handling, storage and protection	11
5.4.9	Buried podiums	11
5.4.10	Further information	11



Figure reference table**Figure Reference Table 5.4**

Fig No	Title/Description	Clause	Page
Figure 1	Basement	5.4	2
Figure 2	Retained ground and semi-basement	5.4	2
Figure 3	Lift pit	5.4	2
Figure 4	Stairs adjacent to the structure	5.4	2
Figure 5	Stepped floor slabs where the retained ground is greater than 150mm	5.4	2
Figure 6	Raised external ground levels	5.4	2
Figure 7	Buried podium	5.4	2
Figure 8	Raised podium	5.4	2
Figure 9	Retaining walls forming lightwells	5.4	2
Figure 10	Split levels	5.4	2
Figure 11	Ground level interface	5.4.6.3	6
Figure 12	Service entry	5.4.6.4	7
Figure 13	Type A system	5.4.7.1	8
Figure 14	Type B system	5.4.7.2	9
Figure 15	Type C system	5.4.7.3	10

Introduction

This chapter includes guidance for walls, floors and foundations below, or near to, ground level that are intended to prevent the passage of water from the ground (including from sources such as run-off, burst pipes, etc) entering the building near to or below ground level.

Guidance for the following types of waterproofing systems is included in this chapter:

- Type A waterproofing barriers
- Type B structurally integral construction
- Type C drained cavity construction.

Constructions that are at risk of coming into contact with water and generally require waterproofing include:

- basements
- semi-basements
- below ground parking areas
- lift pits
- cellars
- storage or plant rooms
- service ducts, or similar, that are connected to the below ground structure
- stepped floor slabs where the retained ground is greater than 150mm.

Types of construction that, depending on the findings of a risk assessment, may require waterproofing include:

- external walls where the lowest finished floor level is less than 150mm higher than the external ground level
- voids caused by split levels.

Typical examples of construction types:

- Waterproofing should be provided where due to the construction details and the ground conditions, there is a risk of contact with groundwater (see Table 1)
- _____ Waterproofing is required

Figure 1: Basement

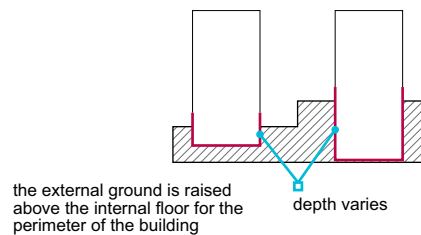

Figure 2: Retained ground and semi-basement

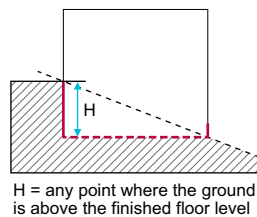

Figure 3: Lift pit

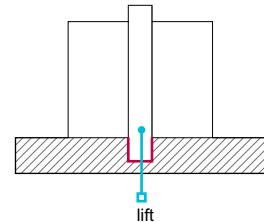

Figure 4: Stairs adjacent to the structure

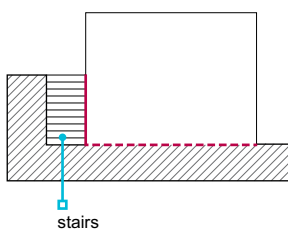

Figure 5: Stepped floor slabs where the retained ground is greater than 150mm

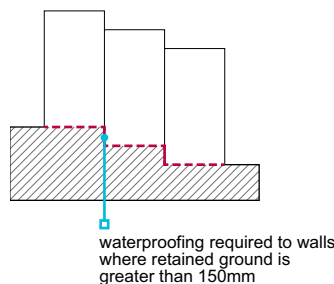

Figure 6: Raised external ground levels

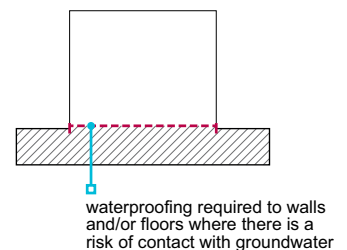

Figure 7: Buried podium

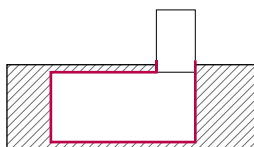

Figure 8: Raised podium

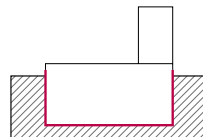

Figure 9: Retaining walls forming lightwells

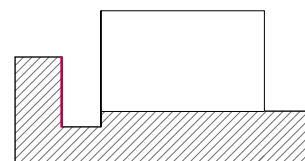
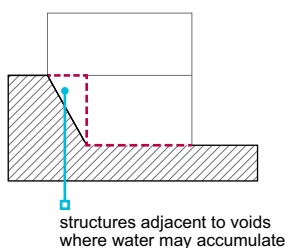

Figure 10: Split levels



the below ground waterproofing must have continuity with waterproofing to the raised podium that itself should have continuity with the superstructure damp proofing (also see Chapter 7.1 Flat roofs and balconies)

Definitions for this chapter

For the purposes of this chapter, the following definitions apply:

Cavity drain membrane	Semi-flexible sheet designed to form a cavity that intercepts water penetrating the structure and directs it to a suitable drainage point. See Type C drained cavity construction.
Combined system	For the purposes of this chapter, a combined system includes: <ul style="list-style-type: none"> • Type A and Type B • Type A and Type C • Type B and Type C It does not include Type A and Type A of different performance characteristics as recognised in BS 8102.
Ground barrier	A barrier used to resist the ingress of moisture and/or hazardous gases into the building.
Lowest finished floor level	The top surface of the lowest finished floor, including lift pit floors, car park surfaces and other similar surfaces; excluding coverings such as carpet and tiles.
Retained ground	In this chapter retained ground levels are taken from the top of the retained ground to the lowest finished floor level.
Type A fully bonded barrier	Type A barrier that forms part of a composite structural wall, including liquid applied and cementitious systems. Typically, when membranes, they will prevent water from tracking from a defect in the membrane to a crack/joint in the structure. Post-applied sheet membranes are not considered to be fully bonded barriers for the purposes of this chapter.
Type A post-applied membrane	A sheet membrane applied to the completed structure, typically with hot or cold adhesive.
Type A waterproofing barrier	A waterproofing barrier applied to the structural element being waterproofed, also known as tanking.
Type B structurally integral construction	Where the water-resistant properties of the retaining structure provide waterproofing to the building This chapter provides specific guidance for the use of Type B concrete systems cast in-situ, with or without water-resisting admixtures. The principles are applicable to other Type B systems listed in BS 8102.
Type C drained cavity construction	Construction that incorporates a cavity, generally formed with a cavity drain membrane Water is removed from the cavity via a managed drainage system.
Waterproofing design specialist	A suitably qualified person co-ordinating the team involved in the design of waterproofing to basements and other below ground structures.
Waterproofing system	A fully assessed and certified system of compatible materials and components used to provide waterproofing. These are normally considered to be Type A, B or C as defined above.

Also see: Chapter 2.1, BS 8102 and The Basement Information Centre Guidance Document — Basements for Dwellings and Basements: Ground Gases and Structural Waterproofing

5.4.1 Compliance

Basements and other below ground structures shall comply with the Technical Requirements.

Waterproofing of basements and other below ground structures, including foundations, walls and floors that complies with the guidance in this chapter will generally be acceptable.

5.4.2 Provision of information

Designs and specifications shall be produced in a clearly understandable format, include all relevant information and be distributed to all appropriate personnel.

Design and specification information should be issued to site supervisors, relevant specialist subcontractors and/or suppliers and include the following information:

- a full set of current drawings
- details of joints, junctions and service penetrations.
Complex details should be considered and presented in three dimensions
- the manufacturer's information, including relevant parts of the system design manual
- an installation method statement detailing the sequence of works
- a ground condition report
- third-party certifications
- details of the waterproofing design specialist.

Design and specification information should be provided to NHBC at least eight weeks in advance of the works starting on site, in accordance with the NHBC Rules.

5.4.3 Waterproofing

Also see: BS 8102

The design of waterproofing systems shall be undertaken by a suitably qualified person and be appropriate for the specific performance required. Issues to be taken into account include:

- 1) waterproofing design
- 2) risk-based design.

5.4.3.1 Waterproofing design

Waterproofing systems should be designed by a waterproofing design specialist. Designers who have successfully completed the Certified Surveyor in Structural Waterproofing (CSSW) qualification available from the Property Care Association (PCA) are generally acceptable to NHBC. An alternative demonstration of competence may be acceptable, subject to successful review.

The waterproofing design specialist should be appointed in the early design stages to co-ordinate with other designers, including the engineer, and to ensure satisfactory integration of the waterproofing system.

5.4.3.2 Risk-based design

Waterproofing should be appropriate to the risk, and generally assume exposure to a full height of water during the design life of the building.

Combined systems should be used where:

- a Grade 3 environment is needed, and
- the wall retains more than 600mm.

Alternatively, where the builder has demonstrated that the water table is permanently below the underside of the lowest floor slab, a Type B structurally integral concrete system is acceptable without further protection from a combined system.

The following Types of waterproofing are acceptable where a Grade 1b environment is needed and more than 600mm of ground is retained:

- Type A fully bonded barrier
- Type B
- Type C
- a combined system.

5.4.4 Ground conditions

Also see: Chapter 4.1

The waterproofing system shall take account of ground conditions.

The ground conditions should be fully considered by the engineer and waterproofing design specialist in the design of the waterproofing system.

NHBC may request investigation and a report of the ground conditions where the below ground waterproofed structure:

- retains more than 600mm of ground, measured from the top of the retained ground to the lowest finished floor level
- comprises more than 15% of the perimeter of an individual building (eg terraced homes, apartment blocks and detached garages), measured on plan.

The ground conditions report should take into account appropriate investigations, as described in Table 1.

Table 1: Investigation of ground conditions

Further investigation	Guidance and information
Desk study, including review of: <ul style="list-style-type: none"> • groundwater, lost rivers and flooding issues • flood potential of the site • available groundwater data • SuDS impact assessment • flood risk assessment • topography of the site • effects of adjacent surface finishes 	www.environment-agency.gov.uk/homeandleisure/floods www.bgs.ac.uk/geology-projects/groundwater-research/groundwater-data/ www.metoffice.gov.uk/weather/climate/uk-climate climate-change.data.gov.uk Historical Publications Ltd 'The Lost Rivers of London' by Nicholas Barton
Contaminated or aggressive ground and/or groundwater conditions	Testing required where there is the potential for chemically aggressive ground and/or groundwater
Water level change, including potential for flash flooding and waterlogging	Identifying likely fluctuations and short-term flooding events
Impact assessment of groundwater flow where the construction is likely to have a 'damming' effect	Interpretative report by a qualified engineer, hydrologist or hydrogeologist to include: <ul style="list-style-type: none"> • assessment of the direction of groundwater flow • damming effects on the groundwater regime • damming effect of adjacent structures

Where it is necessary to establish the water table, a detailed hydrogeological assessment should be undertaken by a suitably qualified engineer, and include:

- long-term water level monitoring over at least one year to capture seasonal fluctuations
- short-term flooding events that typically occur during autumn and spring
- information based on a suitable number of boreholes monitored at intervals of three months or less.

5.4.5 Structural stability

Also see: Chapters 4.1, 4.2 and 5.1

Elements forming a waterproofing structure below ground including: foundations, walls and floors, shall adequately resist movement and be suitable for their intended purpose. Issues to be taken into account include:

- | | |
|----------------------|--------------------------|
| 1) site conditions | 4) movement |
| 2) structural design | 5) design co-ordination. |
| 3) durability | |

5.4.5.1 Site conditions

Parts of the building constructed below ground level that form the structural elements of usable spaces should be designed by an engineer in accordance with Technical Requirement R5 where they are retaining more than 600mm. Issues that should be taken into account include:

- characteristics of the site
- ground conditions
- hazards.

5.4.5.2 Structural design

The structure should be designed to take account of all imposed loads and actions, including:

- ground movement
- lateral forces from groundwater, retained ground and ground surcharge loads
- buoyancy
- loading from other parts of the building
- temporary loading conditions.

5.4.5.3 Durability

The structure should be designed to be sufficiently durable against site hazards, including:

- chemicals
- frost action
- cyclical wet-dry conditions.

5.4.5.4 Movement

Movement within the structure should be limited to the capacity of the waterproofing system's resistance to such movement, ensuring that the designed level of watertightness is achieved. Detailed guidance for the limitation of movement should be provided where appropriate.

Movement joints in below ground waterproofed structures should be avoided and adopted only as a last resort. Although there are likely to be movement joints in the superstructure, typically they are not required to be continued through. Where it is necessary to provide movement joints, the design should clarify why they are necessary and ensure satisfactory in-service performance, including watertightness. Such joints should be accessible for maintenance, and not permanently concealed by other structural elements of the building.

5.4.5.5 Design co-ordination

Structural design should be co-ordinated with the design of the waterproofing.

5.4.6 Design considerations

Also see: Chapters 5.1, 5.2, 5.3 and 6.3

The waterproofing of all elements, including walls, floors and foundations, forming below ground structures shall be suitable for intended use. Issues to be taken into account include:

- 1) grade of waterproofing protection
- 2) waterproofing systems, materials and components
- 3) interface with the above ground structure
- 4) joints, abutments and service penetrations
- 5) steps and level changes.

5.4.6.1 Grade of waterproofing protection

Waterproofing systems should be designed to resist the passage of water and moisture to internal surfaces.

The waterproofing grade should be appropriate for the proposed use of the internal space and the equipment located within.

Table 2: Waterproofing grades

Grade	Description	Generally required for:
Grade 3	No water ingress or damp areas is acceptable. Ventilation, dehumidification or air conditioning necessary; appropriate for the intended use.	Habitable accommodation
Grade 2	No seepage is acceptable. Damp areas as a result of internal air moisture/condensation are tolerable; measures might be required to manage water vapour/condensation.	Non-habitable areas, such as car parks, storage or plant rooms where the internal finishes are not readily damaged by moisture (Some water ingress may occur where openings are provided in car parks, eg for ventilation. To minimise potential for standing water, refer to Chapter 9.1 A consistent approach to finishes. Car parks should be provided with drainage to a suitable outfall).
Grade 1b	No seepage. Damp areas from internal and external sources are tolerable.	
Grade 1a	Seepage and damp areas from internal and external sources are tolerable, where this does not impact on intended use.	Retaining walls typically used to form external lightwells (Drainage may be required to deal with seepage).

Where there is doubt about potential use, minimum Grade 3 protection should be considered in the waterproofing design.

5.4.6.2 Waterproofing systems, materials and components

Components forming the waterproofing system should be predefined and assessed to demonstrate suitable performance.

The assessment should recognise waterproofing may extend or continue across different substrates and/or other materials, products or building systems, or that materials and components may be interchangeable between systems. To ensure performance will be maintained, checks should be undertaken on chemical and adhesive compatibility before installation. Manufacturers often have material compatibility data that can be referred to, however undertaking on-site tests prior to full application are recommended to verify predicted suitability. Substrates should be suitably primed, prepared, dried, cured, cleaned of dirt, dust or other debris and/or protected in accordance with manufacturers' instructions throughout the site works.

The design information and documentation should detail waterproofing systems, materials and components in accordance with manufacturers' recommendations.

Proprietary waterproofing systems, materials and components should be assessed in accordance with Technical Requirement R3.

5.4.6.3 Interface with the above ground structure

Waterproofing should extend at least 150mm above the external ground level and connect with the superstructure damp proofing. This can generally be achieved by linking the below ground waterproofing system to a continuous cavity tray.

The connection between the below and above ground waterproofing should be bonded and formed with appropriate materials.

Where the waterproofing is linked to the above ground structure via a cavity tray, the materials should:

- compress to form a watertight seal
- be capable of taking the load.

Bitumen-based materials in accordance with BS 6398 or suitable materials assessed in accordance with Technical Requirement R3 should be used.

Figure 11: Ground level interface

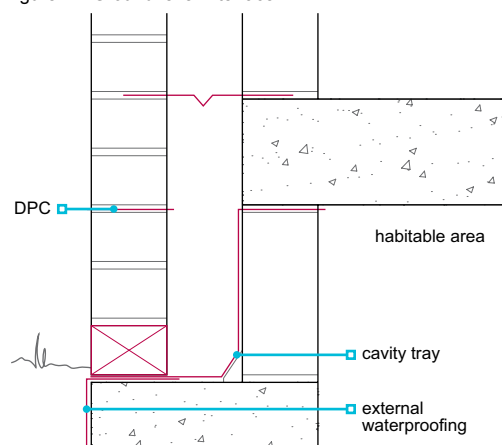

5.4.6.4 Joints, abutments and service penetrations

The design of waterproofing systems should include the correct method and detailing to form joints, abutments and service penetrations, including those between:

- the waterproofing system and superstructure damp proofing
- horizontal and vertical waterproofing
- system components.

The manufacturer should confirm compatibility between different materials where they are used to form joints.

Details of how junctions and abutments are formed should be provided to site personnel. Proprietary components that are part of, or compatible with, the waterproofing system should be used for complex joints, abutments and service penetrations.

Figure 12: Service entry

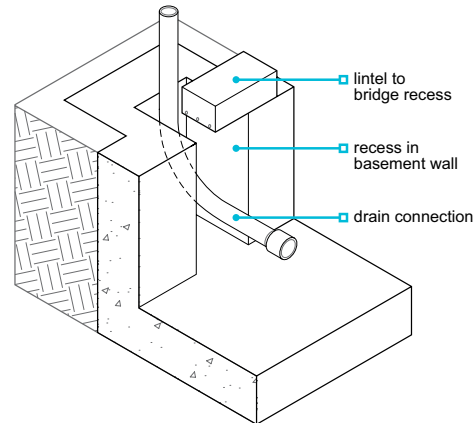

Penetrations through the waterproofing should be avoided where possible. Where penetrations cannot be avoided, the design should detail the method of waterproofing to ensure that it is watertight and durable.

Penetrations, including those for wall ties, services and drainage systems, should:

- be suitably separated to allow for proprietary seals to be correctly installed
- account for differential settlement and movement between the structure/finishes and services.

5.4.6.5 Steps and level changes

Situations where steps and level changes occur within buildings are not uncommon and it is often necessary to consider where normal damp proofing arrangements are likely to become ineffective, resulting in a need for waterproofing to be applied.

Issues to be taken into account include:

- nature of both the substructure and superstructure constructions and their resistance/susceptibility to liquid water and/or water vapour. For example, use of timber or light gauge steel framed superstructures, requirements for drained and/or vented cavities, ability for timber sole plates to breathe, inclusion of insulation(s)
- height difference between finished floor levels
- height of soil retention and/or presence of voids
- robustness of damp proofing or waterproofing solution(s) proposed
- accessibility for repair
- ground conditions and hydrology
- inclusion of subsurface drainage
- provision and continuity of damp proofing to walls and/or floors, interface with the above ground structure (particularly relevant should hazardous gases be present)
- relationship between internal and external ground levels
- continuation at returns, possibly of a different construction type (for example a change from solid to cavity walls or from concrete to masonry construction). Such situations should be considered in three dimensions.

5.4.7 Waterproofing systems

Also see: Chapters 3.1, 3.2, 4.1, BS 8102 and The Concrete Centre Concrete Basements Guidance on the design and construction of in-situ concrete basement structures

The waterproofing shall be suitable for intended use and installed in accordance with the design. Issues to be taken into account include:

- 1) Type A waterproofing barriers
- 2) Type B structure, integral
- 3) Type C drained cavity
- 4) ancillary components.

Appropriate sequencing of work will enable logical and timely construction of the waterproofing system and prevent unnecessary damage to completed elements of work. Installation should be undertaken in accordance with the design and the installation method statement detailing the sequence of works.

5.4.7.1 Type A waterproofing barrier

Type A systems generally accepted by NHBC when assessed in accordance with Technical Requirement R3 include:

- post-applied membrane (hot or cold adhesive)
- liquid-applied membranes
- geosynthetic (bentonite) clay liners
- mastic asphalt to BS EN 12970
- cementitious systems
- pre-applied fully bonded systems
- proprietary systems or products assessed in accordance with Technical Requirement R3.

Plain polyethylene sheet should not be used as a waterproofing system.

In addition to key characteristics typically declared on product marking or technical literature, when assessing Type A system suitability it could also be important to consider its crack bridging ability and/or resistance to aggressive exposure environments (eg to UV, chemicals or hazardous gases) depending on the system's location, the substrate to which it is applied and the substrate's potential performance under load (eg for there to be cracking, a potential for cracks to generate and for these to be dynamic).

Only fully bonded systems assessed in accordance with Technical Requirement R3 for the specific purpose should be used internally.

Design at junctions and corners should account for proprietary components and be in accordance with the manufacturer's recommendations. Waterproofing barriers should return at corners to prevent water tracking behind.

The substrate to which the Type A system is to be applied should be clean, free from debris and prepared in accordance with the manufacturer's recommendations. Bonded sheet membranes should only be applied directly to masonry substrates that are smooth and have flush pointed joints.

Type A waterproofing should be installed in accordance with the manufacturer's instructions by operatives:

- who are suitably qualified or have been trained by the manufacturer or supplier, and
- who are fully aware of the design and the manufacturer's recommendations for installation.

Completed waterproofing should be protected by:

- protection board, or
- carefully placed backfill material.

The manufacturer's recommendations for climatic conditions at the time of installation should be followed.

5.4.7.2 Type B structure, integral construction, concrete and application

Structural design should be undertaken by an engineer in accordance with Technical Requirement R5. The design of in-situ Type B concrete systems should be in accordance with:

- BS EN 1992-1-1
- BS EN 1992-3
- Chapter 3.1 Concrete and its reinforcement.

Type B systems acceptable to NHBC include:

- in-situ concrete with or without water-resisting admixtures and crack widths limited by design
- in-situ high-strength concrete with crack widths limited by design and post-construction crack injections
- precast concrete systems assessed in accordance with Technical Requirement R3.

BS 8102 contains advice on the relationship between tightness classes given in BS EN 1992-3 and grades of performance given in BS 8102 for Grades 1a and 1b. Specialist advice should be sought where other Type B systems are specified.

Ready-mixed concrete should be of sufficient strength and durability, and from a supplier operating under a quality control system acceptable to NHBC such as:

- the Quality Scheme for Ready-Mixed Concrete (QSRMC), or
- the BSI Kitemark scheme.

Other suppliers may be accepted if they operate to a standard acceptable to NHBC.

Figure 13: Type A system

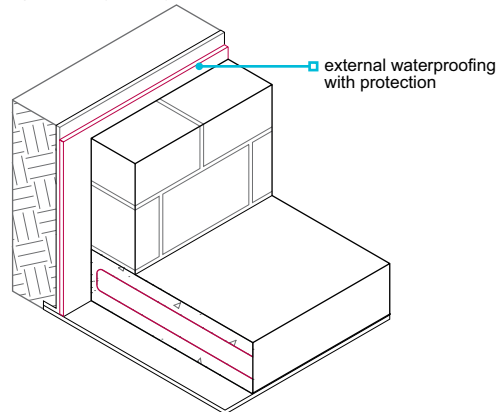
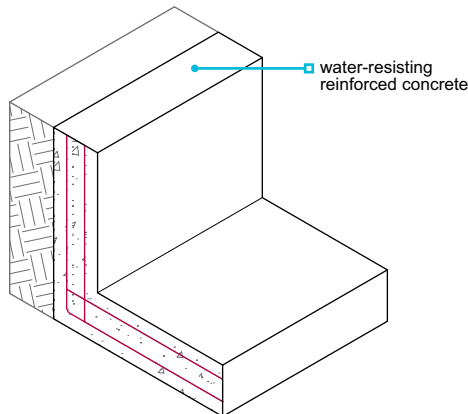

Figure 14: Type B system



The concrete mix should be agreed between the engineer and the waterproofing design specialist, and:

- achieve the necessary robustness, durability and waterproofing
- be suitable for the environmental exposure and ground conditions.

Type B waterproofing should be installed:

- by suitably qualified operatives who are fully aware of the requirements for placing concrete and reinforcement and for installing ancillary components used in Type B systems
- in accordance with the design.

The line, level and position of formwork and reinforcement should be checked prior to concrete placement to ensure that it is in accordance with the design.

Penetrations from tie bars, etc should be made good in accordance with the design.

Where joints are formed in concrete, surfaces should be clean and free of excessive laitance. Hydrophilic strips should be protected from water before the joint is formed.

Quality management systems and quality audits should be used to record and monitor the placement of concrete on site. Monitoring records should be supplied to NHBC as requested.

Design details for reinforced concrete structures should include:

- concrete specification
- type of concrete
- concrete strength
- proportion of any admixture
- proposals for limiting crack widths
- consideration of temporary support to the formwork
- type and position of reinforcement
- method of making good holes in the concrete formed for shutter bolts and tie bars
- positioning of structural elements
- appropriate tolerances for the line and level of structural elements.

Joints between components, including day work joints, should be durable and made watertight with appropriate waterstops or hydrophilic strips. Kickers cast monolithically as part of the slab should be used to form the joint between floors and walls.

Concrete with admixtures

Where the design of in-situ concrete waterproofing includes admixtures:

- the ratio of admixture to concrete specified in the design should take account of the recommendations of the admixture supplier and requirements of the independent assessment
- the reinforcement should be used to control crack widths, which should be in accordance with the design, but not be greater than 0.3mm maximum for flexural cracks and 0.2mm maximum for cracks that pass through the section
- suitable quality management systems and quality audits should be used to record and monitor the batching of admixture. This is best achieved by using ready-mixed concrete (see Clause 3.1.5).

Admixtures should be:

- independently assessed, in accordance with Technical Requirement R3
- assessed according to the intended use
- used strictly in accordance with the manufacturer's recommendations and requirements of the independent assessment.

Concrete without admixtures

Where the design of in-situ concrete waterproofing does not include admixtures:

- high-strength concrete may be specified in order to achieve the necessary level of waterproofing, but post-construction crack injection may be required in order to deal with cracking induced by increased thermal and shrinkage strains
- the reinforcement should be used to control crack widths, which should be in accordance with the design, but not be greater than 0.2mm maximum for both flexural cracks and for cracks that pass through the section
- a minimum section thickness of 250mm should be used in the design.

5.4.7.3 Type C drained cavity construction

Type C systems rely on water being resisted by the structure, with any water penetrating the external shell of the structure being collected within a cavity and directed to a suitable discharge point. The cavity may be formed between the external wall and an inner lining/wall or by a cavity drained membrane.

Factors influencing the amount of water that could enter the cavity are:

- resistance of the structure to water ingress
- size of structure
- volume and flow of external water
- hydrostatic pressure.

Features of the structure could also have an influence, for example service penetrations, construction joints, movement joints or dry packing.

Type C systems formed using a drained masonry cavity wall should follow the guidance in BS 8102. Type C systems that include a cavity drained membrane which forms a waterproof barrier are acceptable to NHBC when assessed in accordance with Technical Requirement R3.

Suitable discharge points should be reached by a designed drainage system, either by gravity or through a sump and pump, to adequately dispose of collected water. Drainage channels, sumps and pumps should include appropriately located access points for servicing and maintenance. To prevent backflow, the drainage system should be fitted with a one-way valve. Also, in areas which are susceptible to flooding the guidance in BS 8102 concerning inclusion of a flood loop should be considered.

Particular care should be taken if adopting Type C systems on contaminated sites to ensure no pathways are introduced that could present a risk or risks to the end user(s) and/or that systems are suitably chemically resistant; specialist advice should be sought.

Type C waterproofing should be installed in accordance with the manufacturer's instructions by operatives:

- who are suitably qualified or have been trained by the manufacturer or supplier
- who are fully aware of the design and the manufacturer's recommendations for installation
- using the fixings recommended by the manufacturer.

Pump systems should operate automatically and include:

- a primary pump
- a secondary pump with battery or generator backup
- a suitable audio or visual alarm that indicates pump failure.

Further guidance on multi-level and inverted cavity drain systems can be found in BS 8102.

Free lime and/or mineral salts leach from new construction with water ingress, which can deposit within cavity drained membranes, drainage channels and pump sump chambers. It is therefore important to ensure access points for servicing and maintenance are well considered and a maintenance plan prepared.

Anti-lime solutions as advised by the waterproofing design specialist may, or, as required by manufacturer's instructions should, be employed to minimise risk that can be further reduced by cleaning and removing loose debris from the structure before closing cavities or applying cavity drained membranes.

Figure 15: Type C system

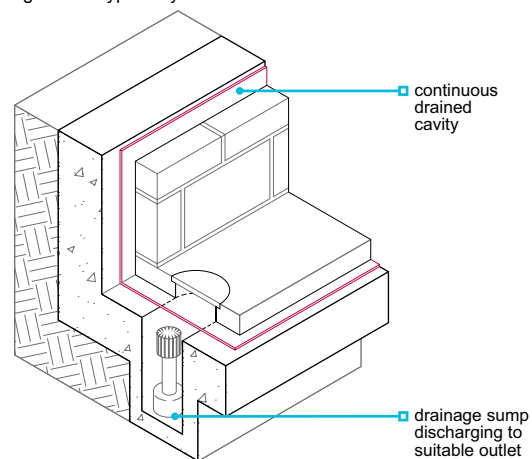

5.4.7.4 Ancillary components

Ancillary components should be assessed as part of the waterproofing system. Alternatively, an assessment of compatibility satisfactory performance should be provided for materials and products that are interchangeable between different systems.

Ancillary components include:

- preformed junctions and corners
- reinforcement
- waterstops
- hydrophilic strips.

5.4.8 Handling, storage and protection

Waterproofing materials, products and systems shall be handled, stored and protected in a satisfactory manner to prevent damage, distortion, weathering or degradation. Issues to be taken into account include:

- 1) handling and storage
- 2) protection from ongoing works.

5.4.8.1 Handling and storage

Materials, products and systems should be transported, lifted, handled and stored in accordance with the manufacturer's recommendations.

5.4.8.2 Protection from ongoing works

Design should consider the risk of damage caused by ongoing works. Details of suitable protection measures should be specified in the design and include:

- fixing of other components, such as skirtings, wall ties and wall linings
- protection of the waterproofing from backfilling.

Proprietary products and systems should be protected and tested before backfilling occurs.

5.4.9 Buried podiums

Also see: Chapters 7.1, 10.1, BS 8102 and PCA's Best Practice Guidance Podium Decks and Buried Roofs

Buried podiums shall be protected by adequate waterproofing and drainage.

A buried podium forms a below ground roof to an area of basement that extends beyond the outline of the main building or buildings above. The waterproofing layer must link with damp proofing in any abutting walls. In most cases, the waterproofing should extend to DPC level or a minimum of 150mm above finished external ground level.

The make-up of the waterproofing layer and subsequent toppings that could include sustainable green, biodiverse (brown) or blue roofs, and provisions for drainage, should be co-ordinated at the planning stage. Guidance on the design, detailing and construction of sustainable roof and associated drainage systems (SuDS) is covered in Chapter 7.1 Flat roofs, terraces and balconies.

Provisions should be made to ensure the waterproofing layer and drainage system will not be susceptible to damage or obstruction from tree/vegetation root activity or structural movement. Drainage design should prevent ponding or accumulated/retained water unless part of a proprietary rainwater attenuation system (also see below).

Structural designs should allow for loadings from emergency, maintenance or other vehicular traffic access, mature planting/trees and/or saturated ground, as applicable. Further allowance should be taken of accumulated/retained water where blue roofs are adopted, or it is otherwise predicted by design (but kept to an absolute minimum), for example in the case of a drainage system temporary service fault or blockage prior to overflow provisions, land drainage or another water relieving strategy becoming active.

5.4.10 Further information

- *BS 8102:2022 Protection of below ground structures against water ingress — Code of practice*
- *The Basement Information Centre Basements: Ground Gases and Structural Waterproofing (updated June 2024)*
- *The Basement Information Centre Guidance Document — Basements for Dwellings (2014)*
- *The Concrete Centre Concrete Basements — Guidance on the design and construction of in-situ concrete basement structures (April 2012)*
- *Property Care Association (PCA) Best Practice Guidance — Podium Decks and Buried Roofs (March 2017)*



Part 6

Superstructure (excluding roofs)



External masonry walls

This chapter gives guidance on meeting the Technical Requirements for external masonry walls.

6.1.1	Compliance	02
6.1.2	Provision of information	03
6.1.3	Structural design	03
6.1.4	Fire resistance	06
6.1.5	Acoustic resistance	07
6.1.6	Exposure	07
6.1.7	Thermal insulation	11
6.1.8	Concrete blocks	15
6.1.9	Bricks	15
6.1.10	Stone masonry	17
6.1.11	Construction of masonry walls	17
6.1.12	Lintels	22
6.1.13	Materials suitable for mortar	24
6.1.14	Mortar	25
6.1.15	Render	26
6.1.16	Cladding	26
6.1.17	DPCs and cavity trays	28
6.1.18	Wall ties, bed joint reinforcements and windposts	35
6.1.19	Handling materials	36
6.1.20	Protection of the works during construction	37
6.1.21	Further information	38



Figure reference table

Figure Reference Table 6.1

Fig No	Title/Description	Clause	Page
Figure 1	Lateral restraint by buttressing wall	6.1.3.2	4
Figure 2	Movement joint sealant	6.1.3.5	5
Figure 3	Lateral restraint and acoustics	6.1.5	7
Figure 4	Checked rebate	6.1.6.2	8
Figure 5	Exposure zones	6.1.6.2	9
Figure 6	Frost exposure zones	6.1.6.3	10
Figure 7	Fully filled insulation	6.1.7.2	12
Figure 8	Insulation to combined lintel ends	6.1.7.2	12
Figure 9	Cavity ties to rigid partial fill insulation	6.1.7.2	12
Figure 10	Internal to external wall bonded connection	6.1.11.2	18
Figure 11	Internal to external wall tied connection	6.1.11.2	18
Figure 12	Dissimilar masonry types	6.1.11.2	18
Figure 13	Masonry cavity wall plumb level	6.1.11.3	19
Figure 14	Striking of mortar	6.1.11.3	19
Figure 15	Rain penetration to mortar joints	6.1.11.3	19
Figure 16	Squareness of window openings	6.1.11.4	20
Figure 17	Masonry setting out at window openings	6.1.11.4	20
Figure 18	Corbelling	6.1.11.5	20
Figure 19	Masonry overhang to openings	6.1.12	22
Figure 20	Combined lintel	6.1.12	22
Figure 21	Separate lintels — reconstituted stone or concrete	6.1.12	23
Figure 22	Separate lintels — steel	6.1.12	23
Figure 23	Lintel end bearing	6.1.12.3	24
Figure 24	Masonry support	6.1.16.1	27
Figure 25	Low level DPC	6.1.17.1	29
Figure 26	Cavity tray to air brick	6.1.17.1	29
Figure 27	Cavity tray to inset meter box	6.1.17.1	29
Figure 28	DPC to stone sill	6.1.17.1	29
Figure 29	Cavity tray to openings	6.1.17.1	30
Figure 30	Cavity tray stop ends and weepholes	6.1.17.1	30
Figure 31	Weepholes to inset gas meter box	6.1.17.1	31
Figure 32	Concrete cavity fill	6.1.17.1	32
Figure 33	Stepped horizontal DPC	6.1.17.1	32
Figure 34	DPC to flashing interface	6.1.17.1	33
Figure 35	Stepped cavity trays	6.1.17.2	33
Figure 36	Parapet walls	6.1.17.3	34
Figure 37	Copings/cappings to parapet walls	6.1.17.3	34
Figure 38	Parapet to external wall junction — DPC/cavity tray arrangement	6.1.17.3	34
Figure 39	Wall tie locations	6.1.18.1	36
Figure 40	Wall tie embedment	6.1.18.1	36
Figure 41	Wall tie to partial fill insulation	6.1.18.1	36

Introduction

This chapter provides guidance on external masonry which is used for the outer and inner leaves of a cavity wall construction, cladding to framed structures and to the limited solid wall construction used in housebuilding such as garages. General guidance on masonry cavity wall construction including the masonry inner leaf of a cavity wall are also provided within this chapter.

The guidance is consistent and complementary to that provided within Chapter 6.9 Curtain walling and cladding, which should be used for products and systems falling under that description.

There is a strong link to all chapters in Part 6 of this standards, particularly Chapters 6.2–6.5, 6.10 and 6.11.

The aim of this chapter is to provide clarity for external and cavity walls constructed of clay and concrete bricks and blocks, as well as natural stone.

Definitions for this chapter

Aggregate concrete masonry unit	Masonry unit manufactured from cementitious binder, aggregates and water, and which may contain admixtures and additions, colouring pigments and other materials incorporated or applied during or after unit manufacture.
Aircrete masonry unit	Masonry unit manufactured from hydraulic binders such as cement and/or lime, combined with siliceous based fine material, cell-generating material and water, and cured with high-pressure steam in autoclaves.
Blocks	Masonry units which, when used in its normal aspect, exceeds the length or width or height specified for a coursing unit (typical brick size). A common block size is 440mm long x 100mm wide x 215mm high.
Bricks	Bricks are designated in terms of their intended use. The co-ordinating sizes for bricks is generally 225mm long x 112.5mm wide x 75mm high. The work sizes are in effect co-ordinating sizes less a nominal thickness of 10mm for the mortar joint.
Clay masonry unit	Masonry unit made from clay or other argillaceous materials with or without sand, fuel or other additives fired at a sufficiently high temperature to achieve a ceramic bond.
Coastal locations	A site within a distance of 500m from the general coastline of the United Kingdom.
Compressive strengths	Where these are quoted in this chapter, they refer to the declared compressive strengths of masonry units.
Co-ordinating size	Size of a co-ordinating space allocated to a masonry unit, including allowances for joints.
Coursing unit	Masonry unit, commonly of brick sizes, used to assist in achieving the storey height of a wall in conjunction with full height blocks.
Fully filled cavity	The insulation thickness is such that it will be in full contact with both leaves of masonry when the building meets normal construction tolerances.
Manufactured stone masonry unit	Facing masonry unit having at least one exposed face with a close structure formed from either one or two homogeneous mixtures of aggregate, cementitious binder and other materials moulded under pressure and/or vibration, and with or without further processing, intended to resemble and be used as an alternative to natural stone.
Masonry	Assemblage of masonry units laid in a specified pattern and joined together with mortar.
Masonry unit	Preformed component intended for use in masonry construction.
Natural stone masonry unit	Masonry unit manufactured from natural stone.
Recessed joints	Where the mortar is raked out, about 5mm from the wall face. There are certain exposure conditions where these should not be used (Clause 6.1.6).
Work size	Size of masonry unit specified for its manufacture, to which the actual size conforms within permissible deviations.

6.1.1 Compliance

Also see: Chapter 2.1

External walls shall comply with the Technical Requirements.

External masonry walls that comply with the guidance in this chapter will generally be acceptable.

6.1.2 Provision of information

Designs and specifications shall be produced in a clearly understandable format, include all relevant information and be distributed to the appropriate personnel.

Designs and specifications should be issued to site supervisors, relevant specialist subcontractors and suppliers, and include the following information:

- construction materials
- wall layout with all dimensions shown
- position and size of openings
- wall layouts and elevations with dimensions shown
- coursing of bricks and blocks in relation to storey heights and opening positions
- all junctions, indicating position of DPCs and cavity trays (isometric sketches are recommended for complicated junctions)
- position and type of lintels
- position of restraint straps
- cavity closers
- reveals
- how support is given to other elements, eg padstones and wall plates
- movement joints
- acceptable methods of pointing or mortar joint finish
- type of insulant to be used
- type, spacing and location of wall ties
- position of fire breaks, cavity barriers and other passive fire-stopping; the required fire resistance period should be specified
- the setting out dimensions (should be masonry co-ordinating dimensions).

Where proprietary products are to be used, manufacturers generally have specific requirements for fixing and/or assembly. This information should also be made available for reference on site so that work can be carried out satisfactorily in accordance with the design and specification.

6.1.3 Structural design

External masonry shall be designed to support and transfer loads to foundations safely and without undue movement. Issues to be taken into account include:

- 1) compliance with relevant standards
- 2) lateral restraint
- 3) concentrated loads
- 4) bonding
- 5) movement joints
- 6) damp proof courses.

6.1.3.1 Compliance with relevant standards

Design of masonry walls should comply with relevant standards:

Structural design	BS EN 1996-1-1 Eurocode 6: Design of masonry structures — General rules for reinforced and unreinforced masonry structures PD 6697 Recommendations for the design of masonry structures to BS EN 1996-1-1 and BS EN 1996-2
Intermediate floors, roofs and walls designed to provide lateral restraint to external walls	BS 8103 (all parts) Structural design of low-rise buildings
Ancillary components	BS EN 845-1 Specification for ancillary components for masonry — Wall ties, tension straps, hangers and brackets BS EN 845-2 Specification for ancillary components for masonry — Lintels BS EN 845-3 Specification for ancillary components for masonry — Bed joint reinforcement of steel meshwork
Walls of homes, or buildings containing homes, over three storeys high	Designed by an engineer in accordance with Technical Requirement R5

6.1.3.2 Lateral restraint

Lateral restraint provided by concrete floors

Concrete floors, with a minimum bearing of 90mm onto the wall, can provide adequate restraint. Concrete floors running parallel to, and not built into, walls require restraint straps to provide restraint to the wall.

Lateral restraint provided by timber floors

Timber joisted floors can provide adequate restraint when joists are carried by ordinary hangers to BS EN 845-1, and connected to the wall with restraint straps. In buildings up to two storeys, timber joisted floors can provide adequate restraint without strapping when:

- the minimum bearing onto masonry is 90mm (or 75mm onto a timber wall plate), or
- joists are carried by BS EN 845-1 restraint-type hangers with performance equivalent to a restraint strap spaced at a maximum of 2m centres.

Lateral restraint provided by buttressing walls

The ends of every wall should be bonded or otherwise securely tied throughout their full height to a buttressing wall, pier or frame. Long walls may be provided with intermediate buttressing walls, piers or support dividing the wall into distinct lengths within each storey, with each distinct length being a supported wall for the purposes of this section.

The intermediate buttressing walls, piers or supports should provide lateral restraint to the full height of the supported wall, and they may be staggered at each storey.

Figure 1: Lateral restraint by buttressing wall

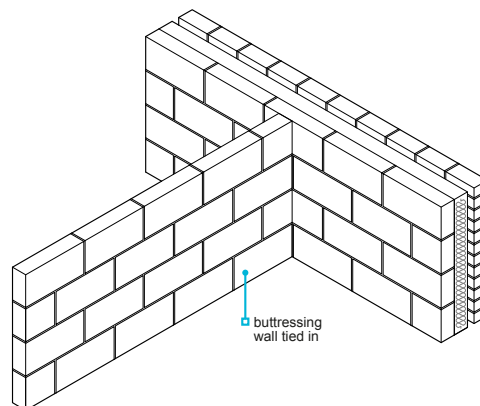

Lateral restraint and acoustics

The ends of separating walls are only tied into the inner leaves and do not have multiple ties across the separating wall cavity at the end of the wall.

6.1.3.3 Concentrated loads

Concentrated loads should be designed by a suitably qualified engineer, for example at the bearing of trimmers, lintels, multi-ply trusses or steel beams.

Where bearing stresses under concentrated loads are greater than the strength of the supporting masonry wall, padstones and spreaders should be provided.

Padstones and spreaders may be required to support concentrated loads.

6.1.3.4 Bonding

Where partition walls abut an external wall constructed of similar materials, fully bonded or tied joints are acceptable. Partition walls may act as buttressing walls mentioned above. To reduce the risk of cracking, a tied joint is preferable where:

- materials have dissimilar shrinkage or expansion characteristics, eg dense concrete and aircrete concrete
- there is a connection between a load-bearing wall on foundations and a non load-bearing wall supported on a ground-bearing slab.

Tied joints should be formed using expanded metal, wire wall ties or a proprietary equivalent, spaced at maximum 300mm intervals. Dissimilar materials should not be used in the same wall (eg clay bricks as 'make up' courses in concrete blockwork walls).

6.1.3.5 Movement joints

Movement joints should be included in long lengths of walling to control expansion or contraction of masonry panels and reduce unsightly cracking, and detailed so that stability is maintained. Where possible, joints should be hidden in corners, or behind rainwater pipes, and:

- run the full height of the superstructure masonry wall
- should not coincide with window and door openings
- continue from those provided in the substructure to the superstructure (movement joints may be needed in the superstructure and not in the substructure, providing suitable allowance is made for relative movement).

Vertical movement joints should be provided in the outer leaf, in accordance with Table 1.

Table 1: Suitable dimensions and spacings for movement joints⁽¹⁾

Material	Joint width (mm)	Normal spacing (m)
Clay brick	16 ⁽²⁾	10–12
Dense concrete bricks	10	7.5–9
Lightweight concrete block and brick (aircrete or using lightweight aggregates) ⁽³⁾	10	6 ⁽⁴⁾
Dense concrete block and reconstructed walling (using dense aggregate) ⁽³⁾	10	7.5–9 ⁽³⁾
Any masonry in a parapet wall	10	Half the above spacings and 1.5 from corners (double frequency)
Natural stone masonry	10 ⁽⁵⁾	15–20 ⁽⁶⁾

Notes

1. Manufacturer's guidance for the provision of movement joints and bed joint reinforcement should be considered.
2. For clay bricks, the joint width in mm should be spacing in metres + 30%, ie, at 8m movement joint spacing, the joint width should be 10mm.
3. Lightweight concrete masonry units are generally made of aggregates that have a gross density not exceeding 1,500kg/m³. Dense concrete masonry units are generally made of aggregates that have a gross density exceeding 1,500kg/m³.
4. The ratio of length to height of the panels should generally not exceed 3:1.
5. As defined within PD 6697.
6. Located no more than 7.5m from an external corner.

The spacing of the first movement joint from a return should not be more than half of the dimension in Table 1.

Movement joints are not generally necessary in the inner leaf of cavity walls, but consideration should be given to providing:

- movement joints in rooms with straight unbroken lengths of wall over 6m
- bed joint reinforcement as an alternative to movement joints in areas of risk, eg under window openings.

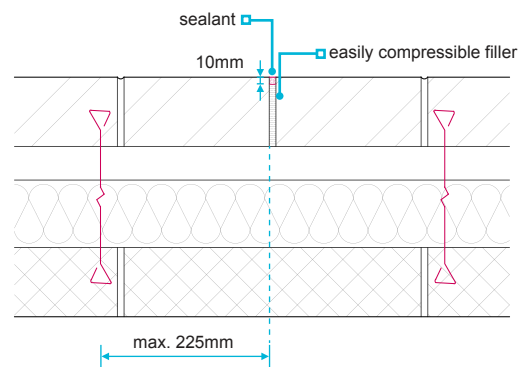
Figure 2: Movement joint sealant

Wall ties should be provided on either side of movement joints, in accordance with Clause 6.1.18.

Where masonry walls form panels in a framed structure, movement joints should be provided in accordance with BS EN 1996-2 and PD 6697.

Movement joints should be formed using the correct materials, and account taken of:

- joint width and depth
- anticipated movement and capability of the material
- surface preparation and backing materials
- likely design life of the joint.

Clay bricks expand and require movement joints formed from easily compressible materials, such as:

- flexible cellular polyethylene
- cellular polyurethane
- foam rubber.

Concrete bricks and blocks contract, and the following materials, are acceptable for use in contraction joints:

- hemp
- fibreboard
- cork.

The joints should be formed using semi-rigid, closed cell polyethylene or other suitable materials.

To perform effectively, a sealant in a movement joint should be applied against a suitable debonding joint filler board/backing rod so that the sealant only adheres to the two opposing masonry faces.

6.1.3.6 Damp proof courses

DPC materials should conform to BS 8215 and PD 6697 Table 1.

Designers should pay adequate attention to the characteristics of the materials chosen for DPCs. Materials that squeeze out or are impaired on highly stressed walls are undesirable and should not be used as DPCs. DPCs' adhesion to mortar, and their ability to resist sliding and/or shear stresses, should be considered, especially in relation to lateral loading.

Where DPCs are required to provide resistance to shear, eg in frame or crosswalled structures, the design of wall panels should reflect this, and the deemed to satisfy rule of Approved Document A, or equivalent regulation, may not be appropriate.

In general, advice on the resistance to compression, tension, sliding and shear should be sought from the manufacturers of the DPC.

6.1.4 Fire resistance

External cavity walls shall adequately resist the passage of fire.

The cavity in the masonry cavity wall of a building can provide a route for the spread of smoke and flames.

Cavities should be closed with cavity barriers, in accordance with Building Regulations.

Cavity barriers should be provided:

- at the edges of cavities, including around openings, eg windows and doors,
- where the cavity abuts compartment walls and floors
- to break up extensive cavities which could act as a route for fire spread.

Vertical cavity barriers, where required, should extend below the DPC, and care should be taken to ensure continuity of cavity barriers where cavity trays are installed at DPC level.

Where cavity barriers are used, they should be sized appropriately for the dimensions of the cavity. Normally, they are installed under compression; as such, maintaining the design cavity width is critical.

Significant reduction in cavity width will mean that the barrier cannot be fitted without creating problems for the following leaf of masonry. Significant widening in the cavity width will mean that the barrier may not be fitted with the appropriate level of compression and its performance may be impaired.

Concealed spaces

Where cladding is fitted to a masonry substrate wall, cavity barriers should be provided. Cavity barriers to concealed spaces behind external cladding should be positioned:

- at the edges of cavities, including eaves and verges, around openings such as windows and doors, and entry/exit points for services
- at the junction between an external cavity wall and every compartment floor and compartment wall.

6.1.5 Acoustic resistance

External walls adjacent to separating walls shall be designed to resist flanking sound transmission.

Acceptable levels of sound reduction between homes may be achieved by:

- the inner leaf of an external cavity wall having sufficient density
- sealing air paths, particularly at junctions between the masonry cavity and separating elements
- allowing appropriate spacing between the openings in external walls
- structural members not transferring across or breaching separating walls.

Figure 3: Lateral restraint and acoustics

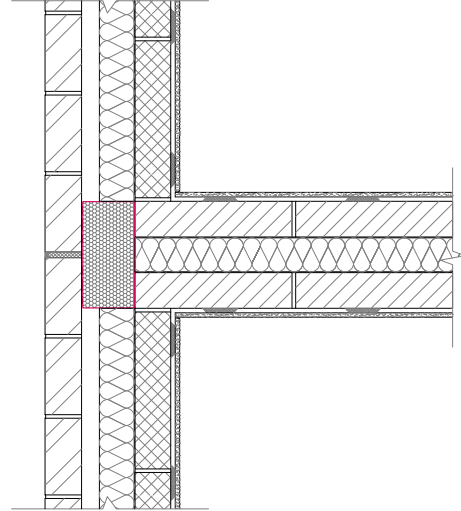

The density of external walls and the position of openings adjacent to separating walls should be in accordance with Building Regulations and, where relevant, an assessment which complies with Technical Requirement R3. Refer to the Robust Details Handbook for the specification of separating wall and floor constructions and their associated flanking walls.

Where different block materials are used, eg aggregate separating wall with aircrete inner leaf, differential drying and cracking can occur, so it is important that the separating wall goes through (and not up to) the inner leaf.

6.1.6 Exposure

Also see: Chapter 6.7

External walls shall be suitable for their exposure and resist the passage of moisture to the inside of the home. Issues to be taken into account include:

- 1) durability
- 2) rain penetration
- 3) freeze/thaw cycles.

6.1.6.1 Durability

Masonry can become saturated, and may remain so for long periods. Therefore, precautions should be taken to resist frost damage and sulfate attack affecting:

- parapet walls and copings
- sills and projections
- masonry below the DPC at ground level
- freestanding walls.

Masonry units and mortar should comply with BS EN 1996-1-1 and be used in accordance with Table 15 of PD 6697 and the manufacturer's recommendations. In addition, mortar mixes should be selected from BS EN 998-2 Table NA.1, and only cement types listed in BS EN 998-2 NA.1.2 should be used.

Cement with sulfate-resisting properties should be used where S1 clay bricks are used in the following situations:

- below the DPC where there are sulfates present in the ground
- below the DPC where there is a high risk of saturation
- retaining walls
- parapets
- freestanding walls
- rendered walls
- areas of severe, or very severe, exposure to driving rain.

Reclaimed bricks should only be used where in accordance with Technical Requirement R3.

6.1.6.2 Rain penetration

In prolonged periods of driving rain, water will penetrate the outer leaf of a masonry wall. The following should be taken into account:

- site-specific exposure to wind-driven rain
- suitability of the wall construction and insulation method
- design detailing for the local exposure, and the likely quality of workmanship on site
- single skin garage walls (additional care needs to be taken to ensure this type of structure does not allow for water penetration prematurely)
- wall tie drips should be located in the centre of the clear cavity
- cavity trays, DPCs and weep vents should be installed in accordance with this guidance.

Exposed parts of the building should be given particular attention when selecting a suitable construction method, as this may affect the choice for the whole building.

Complete resistance can only be achieved with an impervious cladding. However, the following approaches can reduce the risk of rain penetration:

- providing cladding to the wall
- increasing the clear cavity width (minimum 50mm) for partial fill insulation or the width of fully filled cavity insulation (increasing the cavity width for fully filled cavity insulation greatly reduces the risk of rain passing through the cavity)
- rendering the wall and specifying crack-resistant backing material
- designing protective features to keep the wall dry, eg projecting sills and deep overhanging eaves and verges
- ensuring mortar joints are fully filled (where fully filled cavity insulation is proposed, recessed joints should not be used)
- following the recommendations of any assessment of the insulation and the manufacturer's recommendations
- ensuring that cavities are not bridged.

Cavities should be continuous around enclosed porches and habitable areas.

Insulation should be in accordance with Clause 6.1.7 and Table 2.

In Scotland, Northern Ireland, the Isle of Man and other places where the exposure to driving rain is very severe (severe or very severe when building using timber frame), masonry should form a rebate at the reveals of openings to avoid a straight through joint where the frame abuts the masonry, or a proprietary cavity closer assessed in accordance with Technical Requirement R3 should be used.

Sills, copings and similar features should meet the requirements of BS 5642 Parts 1 and 2, and be weathered and throated unless adequate alternative provision is made to protect the brickwork from saturation, frost damage and staining.

Variations to the exposure shown on the map can only be made by site-specific calculations using BS 8104 Code of practice for assessing exposure of walls to wind-driven rain.

Adapted from BRE Report 211 Thermal Insulation: avoiding risks.

Figure 4: Checked rebate

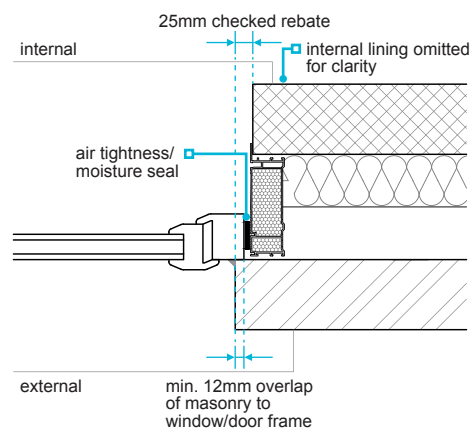

Figure 5: Exposure zones



Exposure zones

	Very severe
	Severe
	Moderate
	Sheltered

Exposure to wind-driven rain (litres/m² per spell)

100 or more
56.5 to less than 100
33 to less than 56.5
Less than 33

6.1.6.3 Freeze/thaw cycles

Common factors which affect the level of freeze/thaw cycles include:

- degree of exposure (incidence of frost)
- saturation of the masonry
- frost resistance of the masonry
- localised protection of the masonry by roof overhangs, trees and other buildings.

Good detailing can limit persistent wetting and reduce the risk of frost attack:

- paths should drain away from walls to avoid saturating bricks near the ground
- sills, copings and similar features should have a weathered upper surface
- a coping or capping should be provided for all parapet walls, chimneys and freestanding walls, unless clay bricks of F2 and S2 classification to BS EN 771-1 are used
- masonry units and mortar should be used in accordance with Table 15 of PD 6697.

Copings should have:

- an overhang
- throatings a minimum of 30mm clear of the wall
- a continuous supported DPC which projects beyond the line of the wall.

The following should be taken into account when selecting bricks:

- manufacturers' recommendations, including the choice and use of mortar and the type of joint finish
- bricks that are not frost-resistant (F0,S2 or F0,S1 to BS EN 771) may not be acceptable for use externally, unless completely protected by a cladding which can adequately resist the passage of water
- where there is a risk that brickwork may be persistently wet, bricks should be specified that are low in soluble salts
- painted or decorated finishes can trap moisture in external brickwork and increase the risk of frost damage, sulfate attack or other detrimental effects. The manufacturer should be consulted to ensure that the proposed decorative finish will not have a detrimental impact on the brickwork durability
- in Scotland, all clay bricks used as facings should be frost-resistant, F2,S2 or F2,S1 to BS EN 771-11, and all concrete bricks used as facings should be 22N/mm² to BS EN 771-3.

Severe exposure to frost attack

The hatched areas on the map opposite have a frost more than 60 days in a year and annual rainfall over 1m, and are 90m above sea level. They are therefore all considered to be at severe exposure to frost.

In areas of severe exposure to frost, the following types of brick are acceptable:

- clay facing bricks which are frost-resistant F2,S2 or F2,S1 to BS EN 771-1
- clay bricks which are classified in the manufacturer's published recommendations as satisfactory for the exposure
- concrete bricks with a minimum strength of 20N/mm² to BS EN 771-3
- concrete blocks with a minimum density of 1,500kg/m³ or compressive strength greater than 7.3N/mm²
- most types of aircrete blocks with render.

Figure 6: Frost exposure zones

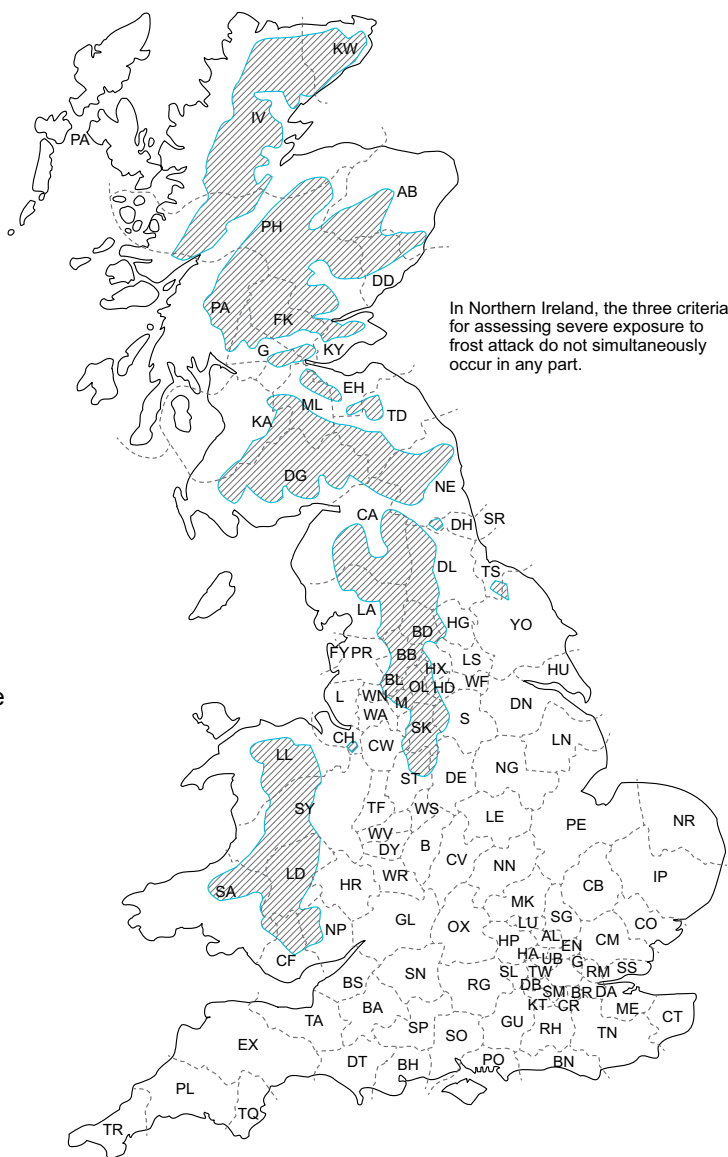

Exceptionally severe frost exposure

These are locations which face long stretches of open countryside and are within an area of severe frost exposure, where only frost-resistant bricks F2,S2 or F2,S1 to BS EN 771 are acceptable for the superstructure.

Where there is doubt about the suitability of a facing brick for sites in areas of exceptionally severe frost exposure, written confirmation should be obtained from the brick manufacturer that the brick is suitable for the geographical location, and location in the structure.

6.1.7 Thermal insulation

Thermal insulation shall be adequate and installed correctly. Issues to be taken into account include:

- | | |
|---------------------------------|---------------------------------------|
| 1) thermal insulation materials | 3) injected and blown fill insulation |
| 2) installation | 4) construction type. |

The insulation value of the wall must meet the requirements of the Building Regulations. Cold bridging should be avoided. Particular care is needed:

- at openings
- between external walls and roofs, internal walls and floors
- behind or around components installed in the cavity such as sub-floor vents, inset meter boxes, cavity trays or windposts.

6.1.7.1 Thermal insulation materials

Relevant standards include:

BS EN 13162	Thermal insulation products for buildings — Factory made mineral wool (MW) products — Specification
BS EN 13163	Thermal insulation products for buildings — Factory made expanded polystyrene (EPS) products — Specification
BS EN 13164	Thermal insulation products for buildings — Factory made extruded polystyrene foam (XPS) products — Specification
BS EN 13165	Thermal insulation products for buildings — Factory made phenolic foam (PF) products — Specification
BS EN 13166	Thermal insulation products for buildings — Factory made extruded polystyrene foam (XPS) products — Specification
BS EN 13167	Thermal insulation products for buildings — Factory made cellular glass (CG) products — Specification
BS EN 14064-1	Thermal insulation products for buildings — In-situ formed loose-fill mineral wool (MW) products — Specification for the loose-fill products before installation
BS EN 16809-2	Thermal insulation products for buildings — In-situ formed products from loose-fill expanded polystyrene (EPS) beads and bonded expanded polystyrene beads — Specification for the bonded and loose-fill products before installation

Thermal insulation materials, either full, partial, or injected and blown fill, that will be placed in the cavity between the outer and inner leaf of masonry should be:

- satisfactorily assessed by an appropriate independent technical approvals authority accepted by NHBC as suitable for the proposed use
- assessed in accordance with Technical Requirement R3.

Thermal insulation materials may:

- either be built in during, or retrofitted after the construction process
- fully or partially fill the cavity.

Materials shall be considered as fully filled cavity insulation where:

- they are designed to be in full contact with both leaves of masonry
- described as fully filled in their technical approval document, although a narrow residual cavity is retained between the outer leaf and the outer face of the insulation.

Partial fill cavity insulation materials shall be installed on the cavity face of the inner leaf, and the appropriate residual cavity to the outer leaf as specified in Clause 6.1.7.4 should be maintained.

All injected and blown fill insulation systems, including blown mineral wool, and expanded polystyrene beads should be:

- installed by the certificate holder or their approved installers subject to the certification bodies' assessment and surveillance scheme, and
- installed by operatives trained by the assessment holder and approved by the assessment holder and the assessing organisation.

6.1.7.2 Installation

Workmanship should be maintained when installing insulation, to minimise the risk of damp penetration or condensation to the inner leaf. Gaps in the insulation layer can provide routes for moisture ingress from the outer leaf to the inner leaf and also create localised cold spots where condensation can form. Gaps between the board and the inner leaf can result in thermal bypass (this is exacerbated by gaps at board junctions). Insulation material should be:

- close butted with no gaps
- in full contact with the inner leaf
- taped at the joints where it is formed of rigid boards with non-compressible edges¹
- fully engaged with the adjacent board edges where a ship lap or other interlocking edge detail is provided
- installed in accordance with the manufacturer's recommendations.

Note

1. Where the insulation has a low e facing the tape face shall have the same low e value.

Where cavity insulation is used:

- mortar joints, including perpend, should be solidly filled with mortar
- mortar droppings should be removed from wall ties and the edges of insulation materials
- excess mortar should be struck flush from the inside of the outer leaf
- excess mortar should be struck flush from the cavity side of the inner leaf.

The first row of insulation boards or batts should be supported on wall ties:

- with a minimum of two ties to each board or batt
- which coincide with horizontal joints in the insulation.

Where wall ties need to be closely spaced, eg at reveals, it is acceptable to make a neat cut in the insulation to accept the extra ties.

Rigid insulation boards should:

- be stored flat without bearers, otherwise they may distort, making them difficult to fix against the wall
- be rejected where warped.

When installing fully filled insulation:

- ensure fibres in the insulation are laid parallel to the wall
- butt joint slabs, and do not bend at internal and external corners
- cover all exposed areas of insulation slabs at the end of each day or in driving rain to prevent excessive moisture in the cavity and pressure on freshly laid masonry from expansion of the insulation
- ensure vertical joints are staggered when layering slabs of insulation.

Figure 7: Fully filled insulation

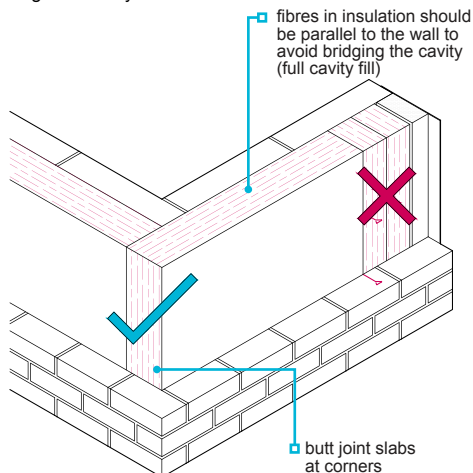

Figure 8: Insulation to combined lintel ends

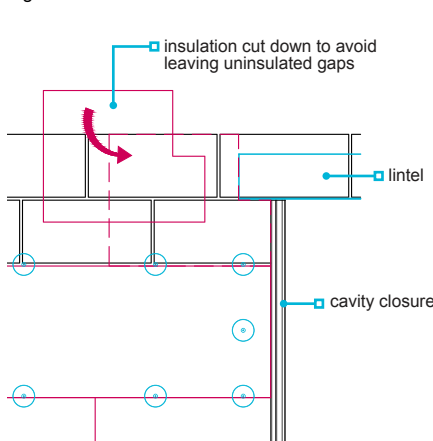
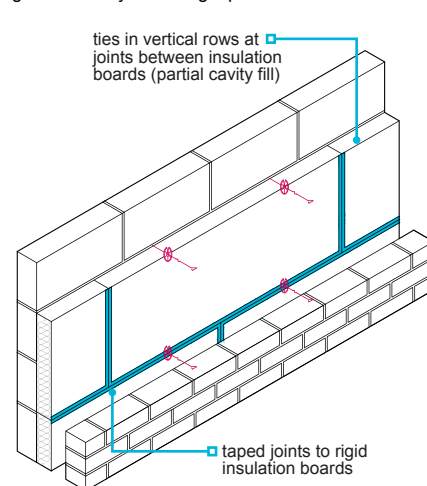

Figure 9: Cavity ties to rigid partial fill insulation



Rigid insulation should not be continuous across the end of a separating wall or floor. A flexible (mineral wool) cavity closer should be used in line with these elements, and the rigid insulation butted up to these.

6.1.7.3 Injected and blown fill insulation

Injected and blown fill insulation should comply with the relevant standards:

Material	Standard	Settlement class
Mineral wool	<p>BS EN 14064-1 Thermal insulation products for buildings. In-situ formed loose-fill mineral wool (MW) products — Specification for the loose-fill products before installation</p> <p>BS EN 14064-2 Thermal insulation products for buildings. In-situ formed loose-fill mineral wool (MW) products — Specification for the installed products</p>	S1
Expanded polystyrene (EPS) beads	<p>BS EN 16809-1 Thermal insulation products of buildings. In-situ formed products from loose-fill expanded polystyrene (EPS) beads and bonded expanded polystyrene beads — Specification for the bonded and loose-fill products before installation</p> <p>BS EN 16809-2 Thermal insulation products of buildings. In-situ formed products from loose-fill expanded polystyrene (EPS) beads and bonded expanded polystyrene beads — Specification for the bonded and loose-fill products after installation</p>	N/A

Injected and blown fill insulation systems should meet the requirements of the relevant standards and hold a satisfactory assessment by an appropriate technical approvals authority acceptable to NHBC, confirming suitability for use in a masonry cavity wall and for the exposure rating of the site.

Separating wall and floor constructions and their associated flanking walls should be detailed correctly when using injected and blown fill insulation. Cavity stops should be installed at the ends of separating walls and separating floors. Refer to the Robust Details Handbook for the specification of materials and construction details.

Before installing injected or blown fill insulation materials, the home should be in a condition ready to receive the insulation. This will be defined in each system's instruction documents but, as a minimum, would require that:

- the cavity wall is inspected by the installing team
- the roof is in place and the tops of the walls are protected from rain
- all edges of cavities at window, door and other openings are closed with the permanent cavity closers, as per the design.

Areas that cannot be accessed during the fill process by appropriate adaptation of the installation method (eg below gas membranes or low level continuous DPCs, where there is a cavity tray one course above a lintel, or where separate lintels are used for each leaf) should be insulated with appropriate built-in materials.

On completion of the work, the installer shall provide a declaration of compliance in accordance with the relevant standard for the product.

6.1.7.4 Construction type

The following are recommendations and guidance according to construction type:

Partial fill cavity insulation

Where partial cavity insulation is installed:

- it should only be fixed against the cavity face of the inner leaf
- a minimum 50mm clear cavity between the partial cavity insulation and the outer leaf should be maintained
- wall ties long enough to allow a minimum 50mm embedment in each masonry leaf should be used.

In areas of very severe exposure in England and Wales, a residual cavity of 75mm is required where the outer leaf is fair faced masonry.

Fully filled cavity insulation

Where the cavity is to be fully filled with insulation:

- the type of insulation, its thickness and the wall construction should be suitable for the exposure of the home (see Table 2)
- render on an external leaf of clay bricks (F2,S1 or F1,S1 designation bricks to BS EN 771) is not permitted in areas of severe or very severe exposure to wind-driven rain
- recessed mortar joints should only be used in sheltered areas
- fair faced masonry includes clay and concrete bricks and blocks, and dressed natural stone laid in an appropriate mortar, preferably with struck, weathered or bucket handle joints
- cavity walls of random rubble or random natural stone should not be used
- painted finishes on bricks or render are not acceptable where they are likely to cause damage (including frost damage or sulfate attack).

Where the cavity is to be fully filled using rigid insulation boards they should be installed in accordance with the current certification and manufacturers recommendations, including where required:

- provision of any residual cavity between the insulation board and the external wall leaf, and
- protection to the edges of boards at corners, etc with tapes or DPCs.

Table 2: Suitable wall construction for use with fully filled cavity insulation

Exposure category	Suitable wall construction	Minimum insulation thickness (mm)		
		Built-in insulation	Injected and blown fill (other than UF foam)	UF foam
Very severe	Any wall with impervious cladding	50	50	50
	Fair faced masonry with impervious cladding to all walls above ground storey	100	125	N/A
	Any wall fully rendered ⁽¹⁾	75	75	N/A
	Fair faced masonry ⁽²⁾	150	150	N/A
Severe	Any wall with impervious cladding or render ⁽¹⁾	50	50	50
	Fair faced masonry with impervious cladding or render ⁽¹⁾ to all walls above ground storey	50	75	50
	Fair faced masonry	75	75	N/A
Moderate	Any wall with impervious cladding or render	50	50	50
	Fair faced masonry with impervious cladding or render to all walls above ground storey	50	50	50
	Fair faced masonry	50	75	75
Sheltered	Any wall with impervious cladding or render	50	50	50
	Fair faced masonry with impervious cladding or render to all walls above ground storey	50	50	50
	Fair faced masonry	50	50	50

Notes

1. Render on an external leaf of clay bricks (F2,S1 or F1,S1 designation bricks to BS EN 771) in severe or very severe exposures is not permitted where the cavity is to be fully filled with insulation.
2. In very severe exposure locations, fair faced masonry with full cavity insulation is not permitted in cavity widths of less than 150mm.
3. This table covers walls where the external leaf does not exceed 12m in height.
4. The exposure category of the home is determined by its location on the map showing categories of exposure to wind-driven rain.
5. Fair faced masonry includes clay and concrete bricks and blocks, and dressed natural stone laid in an appropriate mortar preferably with struck, weathered or bucket handle joints. Cavity walls of random rubble or random natural stone should not be fully filled.

Multiple layers of insulation may be used where in accordance with the manufacturer’s recommendations and within the scope of satisfactory assessment by an independent technical approvals authority accepted by NHBC.

The thickness of materials should be as required in the design, and in accordance with Building Regulations.

Insulated dry linings

Where an insulated dry lining contains a combustible insulant, to prevent early collapse of the lining in a fire, the plasterboard should be:

- a minimum of 12.5mm thick
- mechanically fixed to the masonry inner leaf.

6.1.8 Concrete blocks

Concrete blocks shall be capable of supporting intended loads, have appropriate thermal resistance and be resistant to the adverse effects of climate. Issues to be taken into account include:

- 1) intended loads
- 2) freeze/thaw and sulfate attack
- 3) other characteristics.

6.1.8.1 Intended loads

Concrete blocks should:

- comply with BS EN 771-3 and 4 and PD 6697, and be used in accordance with BS EN 1996-2 and PD 6697
- be used in accordance with the manufacturer's recommendations.
- be of sufficient compressive strength for the application

The maximum load-bearing capacity of the wall should not be exceeded. Other factors may dictate the strength of blocks required in certain circumstances, eg sulfate resistance may require blocks of greater strength.

For one- and two-storey homes, blocks with a minimum compressive strength of 2.9N/mm² could be used.

For three-storey homes or those with storey heights over 2.7m, 7.3N/mm² blocks are required for certain parts of the structure, unless the structural design shows that strengths lower than 7.3N/mm² are suitable.

6.1.8.2 Freeze/thaw and sulfate attack

Concrete blocks used in the outer leaf without protective cladding or render should:

- have a compressive strength >7.3N/mm² or have a density of at least 1,500kg/m³
- be aircrete concrete blocks having had their suitability confirmed by the manufacturer.
- be made with dense aggregate to BS EN 12620, or

Where the level of sulfates in the ground, at the level where blockwork is to be used, is DS-2 or above, their suitability for use should be confirmed by the manufacturer. Where this is permissible, the mortar should be sulfate resisting with a mix suitable for the level of sulfates in the ground.

6.1.8.3 Other characteristics

Concrete blocks may have been specified according to their specific characteristics.

Tolerances

Tolerances should be declared in accordance with the relevant product standard.

6.1.9 Bricks

Bricks shall be capable of supporting intended loads and have appropriate resistance to the adverse effects of freeze/thaw and sulfate attack.

The design strength of bricks should comply with:

- BS EN 1996-1
- the design.

Clay bricks

Table 3: Classification of clay bricks according to their freeze/thaw resistance and active soluble salt content in accordance with BS EN 771-1

Durability	Freeze/thaw resistance	Active soluble salt content
F2,S2	Freeze-/thaw-resistant (F2), durable in all building situations	(S2) low
F2,S1	Freeze-/thaw-resistant (F2), durable in all building situations	(S1) normal
F1,S2	Moderately freeze-/thaw-resistant (F1), durable except when saturated and subject to repeated freezing and thawing	(S2) low
F1,S1	Moderately freeze-/thaw-resistant (F1), durable except when saturated and subject to repeated freezing and thawing	(S1) normal
F0,S2	Not freeze-/thaw-resistant (F0), liable to be damaged by freezing and thawing	(S2) low
F0,S1	Not freeze-/thaw-resistant (F0), liable to be damaged by freezing and thawing	(S1) normal

Bricks that are freeze-/thaw-resistant (F2,S2 or F2,S1 to BS EN 771) should be used where there is a high risk of prolonged wetting and freezing, including:

- external facing work in Scotland
- exposed parts, including copings, sills, parapets and chimneys which have no overhang to provide protection
- areas of the country subject to exceptionally severe freeze/thaw exposure (see Clause 6.1.6).

In areas of severe freeze/thaw exposure outside Scotland, bricks that are moderately freeze-/thaw-resistant (F1,S1 or F1,S2 to BS EN 771) may be used for general wall areas, provided they are classified in the manufacturer's published recommendations as satisfactory for the exposure. Further guidance can also be found within the Brick Development Association (BDA) publication Severely Exposed Brickwork publication.

Bricks that are not freeze-/thaw-resistant (F0,S2 or F0,S1 to BS EN 771) are not acceptable for use externally, unless completely protected by a cladding which can satisfactorily resist the passage of water.

Where brickwork may become saturated, moderately freeze-/thaw-resistant bricks (F1,S1 or F1,S2 to BS EN 771) are not appropriate where there is a risk of vulnerability to frost. In saturated conditions, sulfate-resisting cement mortar is required for S1 designation bricks.

For one- and two-storey homes, clay bricks to BS EN 771, with a minimum compressive strength of 9N/mm², should be adequate.

For three-storey homes, clay bricks to BS EN 771, with a minimum compressive strength of 13N/mm², are acceptable.

Tolerances of clay bricks

Guidance on tolerances for clay bricks can be found within the BDA publication Designing to Brickwork Dimensions.

Concrete bricks

Concrete bricks have a direct relationship between strength and durability, including freeze/thaw resistance. Most concrete bricks have a strength of 22N/mm², are durable in most situations and are equivalent to frost resistance class F2 for clay bricks. For copings and sills, bricks with a compressive strength of 36N/mm² should be used. For one-, two- or three-storey homes, concrete bricks to BS EN 771-3, having a minimum compressive strength of 22N/mm², are acceptable.

Reclaimed bricks

Reclaimed bricks:

- should be used in accordance with Technical Requirement R3
- may require independent certification of suitability, if the durability category cannot be determined
- may require independent certification of suitability
- may be unsuitable for external work because of a high salt content or a lack of freeze/thaw resistance
- which have previously been used internally, or which were fully protected, may be unsuitable in external situations.

It is advisable to know where reclaimed bricks came from, and if they were used internally or externally.

Special shaped bricks (only applicable to clay bricks and concrete bricks)

Special shaped bricks should conform to BS 4729.

Projecting brickwork

Where architectural detailing of brickwork is used to form decorative patterns that include projecting brickwork, exposing either all or part of the width or length of the brick, consideration should be given to:

- perforations or frogs that may be exposed
- visual appearance of exposed bed or differing face surfaces
- suitable weathering of flat surfaces or 'ledges'.

Exposure of projecting bricks, particularly those with frogs or perforations, may affect the durability and service life of the brick. Written confirmation should be obtained from the brick manufacturer that the brick can achieve the required durability for the proposed use.

6.1.10 Stone masonry

Stone masonry shall be constructed to an acceptable standard, including the performance standards for brick and block where applicable. Walls shall be capable of supporting the intended loads and have appropriate resistance to the adverse effects of freeze/thaw.

Stone masonry as the outer leaf of a cavity wall should comply with the following:

Stone for masonry	BS EN 771-6 Specification for masonry units — Natural stone masonry units
Cast stone masonry units	BS EN 771-5 Specification for masonry units — Manufactured stone masonry units or BS 1217 Cast stone. Specification
Stone masonry, natural or cast	BS EN 1996 Design of masonry structures PD 6697 Recommendations for the design of masonry structures to BS EN 1996-1-1 and BS EN 1996-2
Stone for copings and sills	BS EN 12059 Natural stone products. Dimensional stone work. Requirements

Stone masonry as the outer leaf of a cavity wall will be acceptable where it:

- provides an adequate weather-resisting structure in conjunction with any brick or block backing and/or vertical DPMs
- complies with the guidance in this chapter for brickwork/blockwork
- complies with BS EN 12370 or has evidence that it is not susceptible to salt crystallisation when used below DPC level
- follows good local recognised practice to provide a high standard.

Where squared or random rubble is used, it is important that the stone masonry is brought to course at regular intervals of not more than 450mm. Bed joints of up to 25mm wide may be acceptable, and the selection and installation of the correct wall ties should be carefully considered.

6.1.11 Construction of masonry walls

Also see: Chapters 7.1, 9.1 and PD 6697

Construction shall ensure a satisfactory standard of brickwork and blockwork. Issues to be taken into account include:

- 1) finished appearance
- 2) bonding
- 3) construction
- 4) openings
- 5) corbelling
- 6) chasing for services
- 7) protection of ancillary components.

The construction of masonry walls should comply with the following:

- requirements of BS EN 1996-2 Eurocode 6: Design of masonry structures — Design considerations, selection of materials and execution of masonry
- and BS 8000-3 Workmanship on construction sites — Masonry. Code of practice.

6.1.11.1 Finished appearance

A site reference panel should be constructed to agree a benchmark for workmanship and products.

The appearance of a masonry wall depends upon the:

- materials used
- setting out
- workmanship.

When setting out masonry:

- avoid cutting bricks or blocks, except when it is essential
- avoid irregular or broken bonds, particularly at openings
- fair faced masonry bricks should be set out dry, prior to commencement of works.

All work should be reasonably level and true, and:

- the bond detailed in the design used
- perpendicular joints kept in line and plumb
- courses kept level by using lines and spirit levels
- meet the tolerances defined within Chapter 9.1 A consistent approach to finishes.

To keep courses to the correct height, use a gauge rod marked with the height of windows, doors and floors.

Where a number of openings of similar width are being formed, use a rod cut to the required size to check the width of openings as the work rises.

Brickwork and blockwork should not be subjected to vibration until the mortar has set.

6.1.11.2 Bonding

A regular bonding pattern should be maintained. External walls should be bonded to partitions and party walls as required by the design. Either:

- tooth every alternate course, or
- tie with wall ties, expanded metal or equivalent at maximum 300mm vertical centres.

Figure 10: Internal to external wall bonded connection

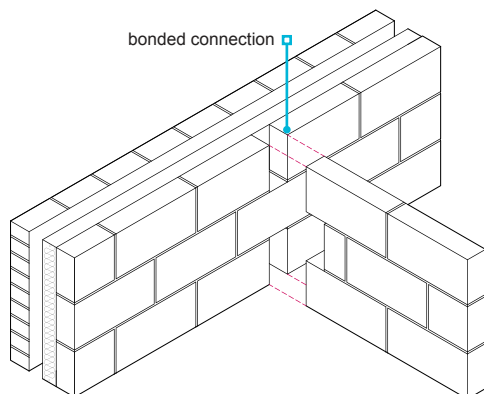
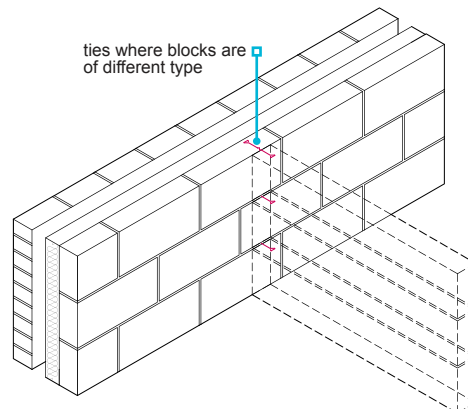

Figure 11: Internal to external wall tied connection



Where joist hangers are not used, joist filling should be brickwork or blockwork and without excessive mortar joints. The recessed portion of timber joists should be treated.

Joist filling should be:

- 12mm below the top of flat roof joists to allow for timber shrinkage
- checked to ensure the cold roof ventilation is not blocked.

Clay bricks and concrete blocks should not be mixed.

Where a different size of masonry unit is needed to ensure correct coursing, small units of the same material should be used to reduce cracking and problems due to different thermal insulation properties.

Where the inner leaf of a cavity wall is being used for thermal insulation, and where a different size of masonry unit is used to ensure correct coursing, the unit should have similar thermal insulation properties to the masonry used for the rest of the wall.

Figure 12: Dissimilar masonry types

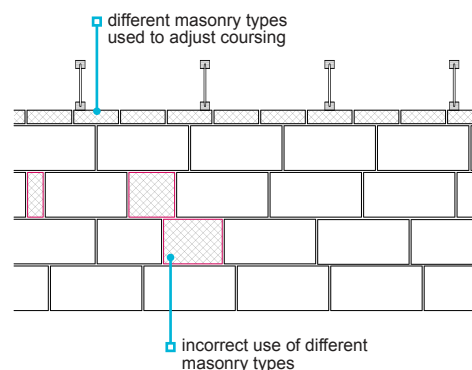

6.1.11.3 Construction

The difference in heights between the two leaves of a cavity wall under construction can be up to six block courses, provided the ties are sufficiently flexible to ensure coursing is achieved without breaking the bond. To keep the wall plumb, do not over-reach at changes of lift; wait for the next scaffolding lift. With thin layer mortar construction having an assessment which complies with Technical Requirement R3, it is normally permissible to build the inner leaf to storey height ahead of the outer leaf. In such cases, the recommendations of the assessment, and the manufacturer's recommendations, should be followed.

Cavities should be constructed so that:

- they are uniform and in accordance with the design, including wall tie specification and cavity width
- mortar is struck from all joints as work proceeds
- cavity trays and wall ties are clear of droppings and debris
- mortar droppings are removed
- where cavity insulation is used, mortar droppings are removed from the top edge
- where partial cavity insulation is used, it is against the inner leaf of the cavity
- the thickness of the external leaf is consistent; any stone used should not project into the cavity
- cavity barriers are installed as the work progresses.

Figure 13: Masonry cavity wall plumb level

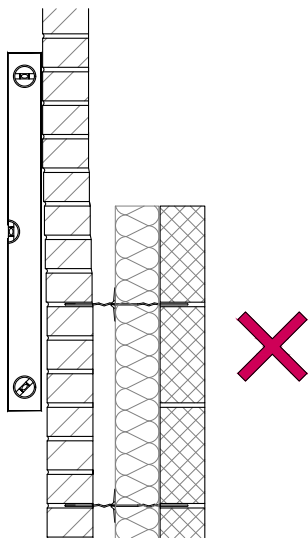
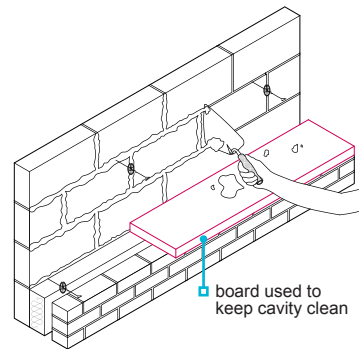

Figure 14: Striking of mortar



Laying bricks and blocks

Bricks and blocks should have a solid mortar bedding and fully filled perpend, to reduce the risk of rain penetration and dampness in the wall. The thickness of bed joints and perpend joints made with general purpose and lightweight mortars should be of a nominal thickness to suit gauge and masonry co-ordinating size and be not less than 6mm nor more than 15mm unless specific manufacturers recommendations are given. Joints should be consistent in width, profile and alignment to meet the tolerances defined with Chapter 9.1 A consistent approach to finishes.

Unless otherwise advised by the manufacturer, bricks with single frogs should be laid with the frog facing upwards, and double frog bricks should be laid with the deeper frog facing upwards. All frogs should be fully filled with mortar.

Where cutting of bricks is required to achieve bond:

- standard work sizes of cut bricks should be used ie, quarter, half and three-quarter cuts
- bricks should be cut cleanly and accurately
- cutting of facing brickwork with a trowel should be avoided.

Special bricks in accordance with BS 4729 should be used to form curves, features (eg plinths or cappings) or angles other than 90 degrees (eg bay windows) which cannot be satisfactorily formed with standard bricks. Cut and stuck specials may be used in accordance with the design where a standard special is not available.

Note

1. Cut and stuck specials may not be appropriate for use depending on the specification of the adhesive bonding used, where the use of combustible materials in the external walls is restricted in certain buildings with a storey 18m or more above ground level.

Protection of cavity walls during construction

Masonry cavity walls shall be protected whenever work stops, eg for inclement weather or overnight. The tops of both leaves, as well as the cavity and any insulation, should be covered with sacking or plastic sheet and appropriately secured in place.

Figure 15: Rain penetration to mortar joints

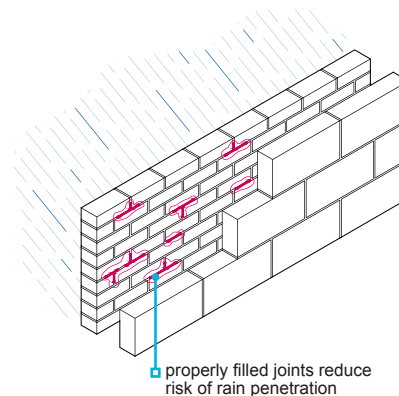

6.1.11.4 Openings

Masonry may be built around either:

- the frame in-situ, or
- a profile or template to enable the frame to be fitted later.

Openings should be the correct size, square and:

- the spacing between the masonry and frame should allow for movement and tolerance
- the frame should not be distorted by forcing bricks against the jamb.

When window and door frames are built in, they should be fixed with:

- frame cramps
- proprietary cavity closers, or
- plugs and fixings.

Proprietary cavity closers should be fitted in accordance with manufacturers' instructions. Cavity closers should be fitted in one continuous piece unless jointing is accepted by the manufacturer and suitable details and installation instructions are provided. The closer should be assessed as suitable for the exposure zone of the site.

Where opening sizes and locations do not match brickwork setting out, brick bonding pattern should be set out at the base of the wall to ensure that cut bricks occur below openings.

Figure 16: Squareness of window openings

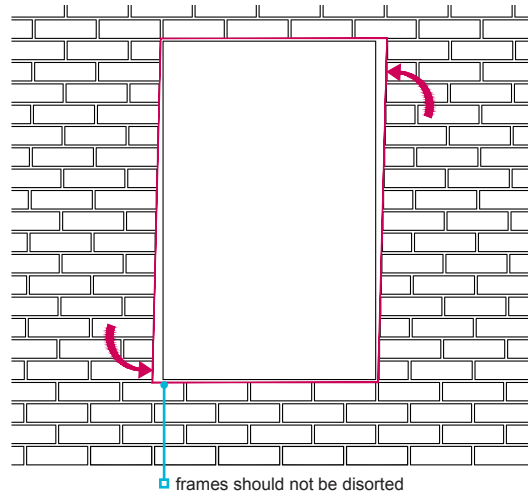
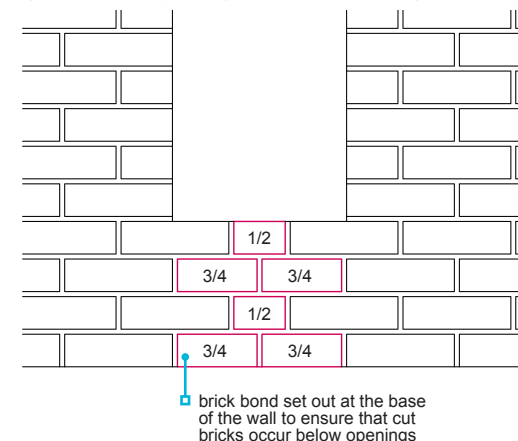

Figure 17: Masonry setting out at window openings



6.1.11.5 Corbelling

For feature brickwork sections, the masonry should only be self-supporting.

Where courses are corbelled outwards in ordinary masonry, one above another, the extent of corbelling should not exceed that shown in the figures on the right.

Where reinforcing is used, corbels should be designed by an engineer in accordance with Technical Requirement R5.

Figure 18: Corbelling

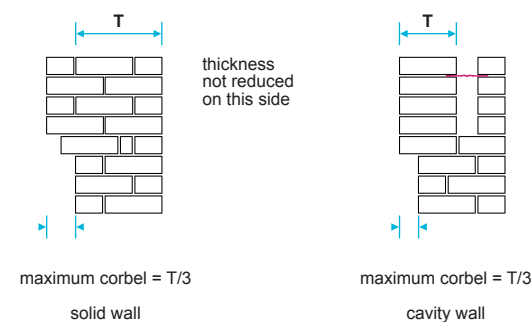

6.1.11.6 Chasing for services

Chases should:

- not be cut with impact power tools, as they can damage the wall
- not cut into hollow blocks unless specifically permitted by the manufacturer
- be cut with care
- be limited to 1/6 of the depth of the leaf where horizontal
- be limited to 1/3 of the depth of the leaf where vertical
- maintain a residual thickness of 15mm between the chase and the void for hollow or cellular blocks unless otherwise recommended by the manufacturer.

6.1.11.7 Protection of ancillary components

Table 4 contains guidance for a selection of ancillary components for use in buildings up to three storeys in height, in a non-aggressive environment.

Table 4: Protection of ancillary components

Product type	BS EN 845 ref ⁽¹⁾	Material/coating specification (the zinc coating masses are for one surface)
Wall ties, tension straps and hangers conforming to BS EN 845-1	1	Austenitic stainless steel (molybdenum chrome nickel alloys)
	3	Austenitic stainless steel (chrome nickel alloys)
	8 or 9	Zinc coated (940g/m ²) steel wire or component
Tension straps and hangers conforming to BS EN 845-1 (internal uses ⁽²⁾)	10	Zinc coated (710g/m ²) steel component
	11	Zinc coated (460g/m ²) steel component
	12.1 or 12.2	Zinc coated (300g/m ²) steel strip or sheet with organic coating over all outer surfaces of finished component
	13	Zinc coated (265g/m ²) steel wire
	14	Zinc coated (300g/m ²) steel strip or sheet with all cut edges organic coated
	15	Zinc precoated (300g/m ²) steel strip or sheet
	16.1 or 16.2	Zinc precoated (137g/m ²) steel strip or sheet with organic coating over all outer surfaces of finished component
	17	Zinc precoated (137g/m ²) steel strip or sheet with organic coating over all outer surfaces of finished component
Lintels conforming to BS EN 845-2	L1	Austenitic stainless steel (molybdenum chrome nickel alloys)
	L3	Austenitic stainless steel (chrome and nickel alloys)
	L10	Zinc coated (710g/m ²) steel component
	L11.1 or L11.2	Zinc coated (460g/m ²) steel component with organic coating over all outer surfaces of finished component
	L12.1 or L12.2	Zinc coated (300g/m ²) steel strip or sheet with organic coating over all outer surfaces of finished component
	L16.2	Zinc coated (137g/m ²) steel strip or sheet with organic coating over all outer surfaces of finished component
Lintels conforming to BS EN 845-2, where used with a separate DPC	L11	Zinc coated (460g/m ²) steel component
	L14	Zinc coated (300g/m ²) steel strip or sheet with all cut edges organic coated
	L16.1	Zinc coated (137g/m ²) steel strip or sheet with organic coating over all outer surfaces of finished component
Bed joint reinforcement conforming to BS EN 845-3	R1	Austenitic stainless steel (molybdenum chrome nickel alloys)
	R3	Austenitic stainless steel (chrome nickel alloys)
	R23	Austenitic-ferritic stainless steel to BS EN 10088 (all parts)
Windpost ⁽³⁾⁽⁴⁾	1	Austenitic stainless steel (molybdenum chrome nickel alloys)
	3	Austenitic stainless steel (chrome nickel alloys)

Notes

1. Material/coating reference in accordance with the relevant part of BS EN 845.
2. These products are not suitable for use in contact with the outer leaf of an external cavity wall or a single leaf cavity wall.
3. Outside the scope of BS EN 845 but meets the specification requirements of BS EN 845-1 for the material/coating reference.
4. Alternative material/coating specification may be provided in accordance with Clause 5.12 and Table 2 of PD 6697:2019 where windposts are not connected to, or embedded in the outer leaf of an external cavity wall.

Components in contact with, or embedded in, an inner leaf which is damp or exposed to periodic wetting (eg below the DPC) should be protected in the same way as components in contact with, or embedded in, an outer leaf.

6.1.12 Lintels

Also see: Chapter 6.5

Lintels, and supporting beams, shall be installed correctly, safely support the applied loads, and be of the type and dimensions appropriate to their position within the structure. Issues to be taken into account include:

- 1) thermal insulation and condensation
- 2) durability and resistance to water entering the home
- 3) placing lintels.

Concrete, steel and reinforced brickwork are acceptable materials for use as lintels. Timber lintels should not be used, unless:

- protected from weather
- they do not support masonry or other rigid or brittle materials.

Figure 19: Masonry overhang to openings

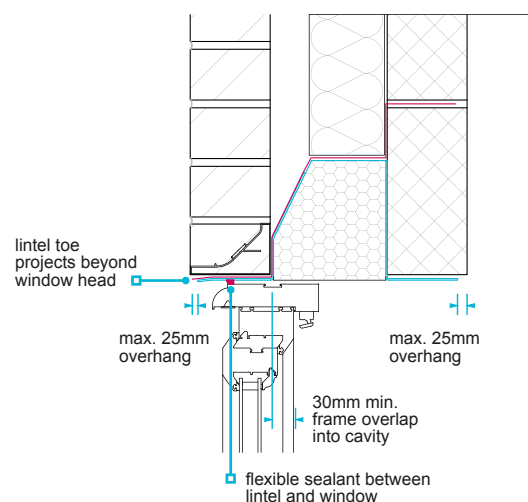

Lintels should:

- comply with BS EN 845-2 Specification for ancillary components for masonry — Lintels, where steel or concrete
- be designed in accordance either with Technical Requirement R5 or the manufacturer's recommendations
- be provided where frames are not designed to support superimposed loads
- be wide enough to provide adequate support to the walling above
- not have brickwork or masonry which overhangs more than 25mm
- have cavity trays where they are specified in the design
- have padstones and spreaders provided under the bearings, where necessary
- not have concentrated loads applied before the manufacturer's requirement of fully bedded brickwork is met (this is to avoid overstressing).

Lintels should extend beyond the opening (at each end) by the minimum lengths shown in Table 5.

Table 5: Lintel bearing

Span (m)	Minimum bearing length (mm)	
	Simple lintel	Lintel combined with cavity tray
Up to 1.2	100 ⁽¹⁾	150
Over 1.2	150	150

Note

1. Minimum bearing lengths should be in accordance with the manufacturer's recommendations.

Where steel lintels are used:

- the manufacturer's recommendations for providing adequate fire resistance should be followed, particularly to the lower steel flange
- the inner and outer leaf should be built up together to avoid twisting the lintel flange
- the difference in height between the leaves should not exceed 225mm.

Figure 20: Combined lintel

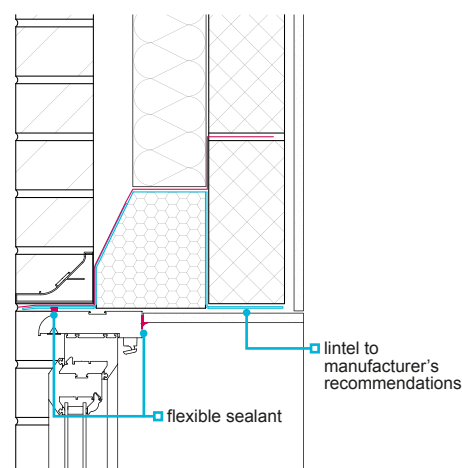

Where separate lintels are used to support the inner and outer masonry leaves:

- the cavity, at the head of the opening, should be closed off with an insulated cavity closer
- a cavity tray should be installed to protect the cavity closer from moisture in the cavity
- the cavity tray should be built into the inner leaf and taken to the outer face of the external wall directly over the outer lintel and not between the cavity closer and lintel.

Figure 21: Separate lintels — reconstituted stone or concrete

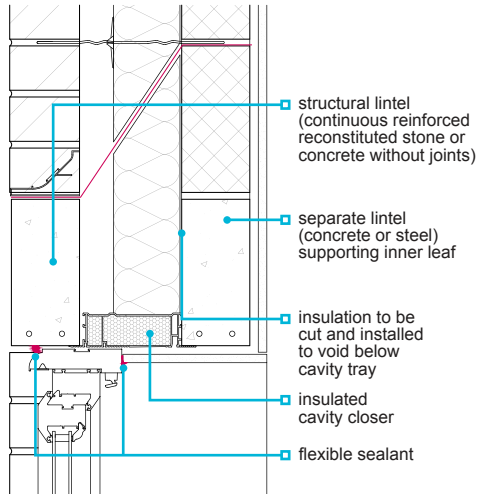
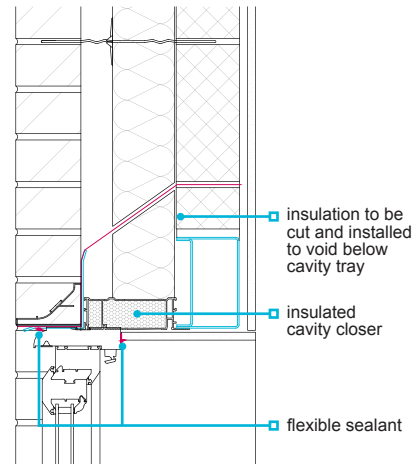

Figure 22: Separate lintels — steel



6.1.12.1 Thermal insulation and condensation

The risk of condensation at potential cold bridges, such as reveals and soffits, increases as the level of wall insulation increases. To avoid cold bridging:

- wall insulation should abut the head of the window frame
- insulation should be provided at the underside of the lintel unless the manufacturer produces an alternative.

6.1.12.2 Durability and resistance to water entering the homes

Cavity tray/damp proof protection should be provided:

- over all openings, either combined as part of the lintel or separate
- where the outer leaf is fair faced masonry, or where fully filled insulation is used, all cavity trays (separate or combined) should have stop ends.

Separate cavity tray protection should be provided when corrosion protection to the lintel is inadequate, or where required by the manufacturer, or the shape of the lintel is unsuitable, such as when:

- the profile of the lintel does not form a cavity tray
- steel lintels in external walls have material/coating in accordance with L11, L14 and L16.1 (see Table 4).

In Scotland, Northern Ireland, the Isle of Man and areas of severe or very severe exposure to driving rain, a separate cavity tray should be provided over all lintels.

Lintels should be:

- austenitic stainless steel (material reference L1, see Table 4) where used in aggressive environments, eg coastal locations
- located and sized so that the external edge of the lintel projects beyond, and therefore offers protection to, the window head.

6.1.12.3 Placing lintels

The design should be checked, and lintels should:

- be an appropriate size for the opening and the end bearings (at each end)
- have padstones where required, eg for long spans
- be installed level on a solid bed of mortar (not soft or non-durable packing)
- be set out to ensure that lintels bear on a full masonry unit
- not have brickwork or masonry which overhangs more than 25mm.

Composite lintels and steel beams should be bedded on mortar to both leaves to ensure an even distribution of the loads. The thickness of the bedding should be sufficient to accommodate any unevenness between the support and a lintel and maintain coursing. Concrete floor units or other heavy components which bear on lintels should be positioned carefully to avoid damage or shock load.

Figure 23: Lintel end bearing

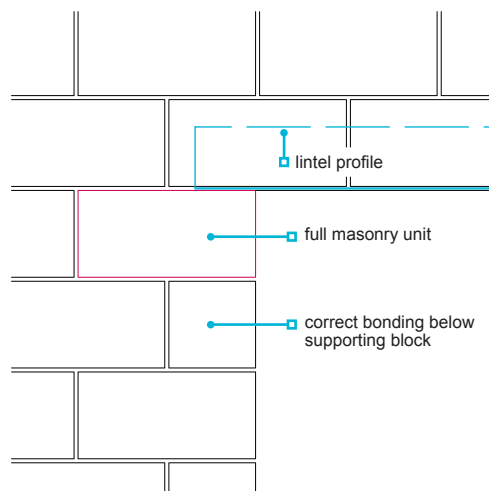

6.1.13 Materials suitable for mortar

Materials used for mortar should comply with the appropriate requirements and standards.

Relevant standards include:

BS EN 197-1	Cement — Composition, specifications and conformity criteria for common cements
BS EN 413-1	Masonry cement — Composition, specifications and conformity criteria
BS EN 459-1	Building lime — Definitions, specifications and conformity criteria
BS EN 998-2	Specification for mortar for masonry — Masonry mortar
BS EN 934-3	Admixtures for concrete, mortar and grout — Admixtures for masonry mortar. Definitions, requirements, conformity and marking and labelling
BS EN 12878	Pigments for the colouring of building materials based on cement and/or lime. Specifications and methods of test
BS EN 13139	Aggregates for mortar

6.1.14 Mortar*Also see: Chapter 3.2*

Mortar shall be of the mix proportions necessary to achieve adequate strength and durability, and be suitable for the type of masonry. Issues to be taken into account include:

- | | |
|-----------------------------|---------------------|
| 1) sources of sulfate | 3) preparing mortar |
| 2) admixtures and additives | 4) joints. |

Unless recommended otherwise by the brick manufacturer, the mixes in Table 6 should be used for clay bricks. In the case of concrete bricks, particular attention should be paid to the manufacturer's recommendations.

Table 6: Mortar mixes using ordinary Portland or sulfate-resisting cements

Location		Recommended cement:lime:sand mix	Recommended cement:sand mix	Recommended masonry cement:sand mix	Mortar designation to BS EN 1996-1-1	Equivalent mortar class to BS EN 1996-1-1
General wall area above the DPC	In areas of severe or very severe exposure — high durability	1:½:4½	1:3½	1:3	(ii)	M6
	Other exposure categories — general use	1:1:5½	1:5½	1:4½	(iii)	M4
Below DPC level and in chimney stacks	High durability	1:½:4½	1:3½	1:3	(ii)	M6
Cappings, copings and sills	Low permeability	1:0 to ¼:3	—	—	(i)	M12

Air-entraining plasticiser can be incorporated in the following general use and high durability mortars:

- 1:1:5½, cement:lime:sand, or
- 1:1:4½, cement:lime:sand.

Retarded mortar

Retarded mortar and most premixed mortars can be used over a longer period of time than site-mixed cement:lime:sand mortars. When using retarded mortar:

- follow the manufacturer's recommendations and timescales
- do not use it beyond the time for which it is effective
- protect it against freezing prior to use
- temporary bracing of larger walls, eg at gable peaks and long walls, may be necessary due to delayed setting times.

6.1.14.1 Sources of sulfate

Mortar is vulnerable to deterioration by sulfates, especially when masonry is saturated for long periods of time. Clay bricks contain soluble sulfate (S1 designations have no limit on their sulfate content), so a suitable mortar should be used.

To reduce risk, cement types listed in BS EN 998-2 NA.1.2 with sulfate-resisting properties or alternatively CEM II cements based on blast-furnace slag are in widespread use where sulfate resistance is required, and should be used:

- below the DPC level when sulfates are present in the ground
- when there is a high saturation risk (examples below).
- when clay bricks (F2,S1 and F1,S1 to BS EN 771) are used

High saturation risk situations are:

- below the DPC
- areas of severe or very severe exposure to driving rain
- parapets
- retaining walls
- freestanding walls
- rendered walls
- chimney stacks.

6.1.14.2 Admixtures and additives

Admixtures should:

- only be used where agreed with the designer
- not contain calcium chloride
- be dosed and used in accordance with the manufacturer's recommendations.

Mortars containing an air-entraining plasticiser are more resistant to freeze and thaw damage when set, but do not prevent freezing before the mortar is cured.

White cement to BS EN 197 and pigments to BS EN 12878 may be used, but pigments should not exceed 10% of the cement weight, or 3% where carbon black is used.

6.1.14.3 Preparing mortar

When preparing mortar:

- ensure the mix is appropriate for the use and location
- plant and banker boards should be kept clean
- mixers should be kept clean to operate efficiently
- the colour should be consistent.

When laying bricks and blocks:

- mortar should be the correct mix and used within two hours, unless it is retarded mortar
- mortar which has started to set should not be retempered.

Note

1. Thin layer mortars are supplied in bag form and should be mixed with water on site strictly following the manufacturer's recommendations.

6.1.14.4 Joints

Jointing is preferable to pointing because it leaves the mortar undisturbed. Struck (or weathered) and bucket handle joints are preferable for external walls. Unless the design states otherwise, only bucket handle or weathered joints should be used.

Recessed joints should not be used where:

- bricks are not frost-resistant, eg clay F1,S1 or F1,S2 to BS EN 771, unless the brick manufacturer has confirmed their use for that particular location in writing
- the home is built on steep sloping ground, facing open countryside or within 8km of a coast or large estuary
- bricks are perforated closer than 15mm to the face
- there is no reasonable shelter from driving rain, eg from buildings or groups of trees within 50m and of similar height to the home
- the cavity is to be fully filled with cavity insulation.

6.1.15 Render

Also see: Chapter 6.11

The surface to which render is applied shall be appropriately constructed and satisfactorily resist the passage of moisture.

Walls to be rendered should be constructed in accordance with the relevant parts of this chapter. For detailed guidance, see Chapter 6.11 Render.

6.1.16 Cladding

Also see: Chapters 3.3, 6.2 and 6.9

Cladding shall satisfactorily resist the passage of moisture and be of the quality, type and dimensions required by the design. Issues to be taken into account include:

- 1) masonry cladding to framed structures
- 2) joints
- 3) materials for cladding
- 4) vertical tile or slate cladding
- 5) stone veneer cladding.

This clause is for low-rise applications where the masonry is used directly for weathertightness or used in conjunction with other vertical cladding for weathertightness. Chapter 6.9 covers curtain walling and other structural cladding.

Refer to the Robust Details Handbook to check compatibility of lightweight external treatments.

Where external claddings such as fibre cement, timber or tile hanging are installed on masonry walls, cavity barriers should be provided:

- at the edges of cavities, including eaves and verges, around openings such as windows and doors, and entry/exit points
- at the junction between an external cavity wall and every compartment floor and compartment wall.

6.1.16.1 Masonry cladding to framed structures

Allowance should be made for differential movement between cladding and the frame. The following precautions should be taken to prevent buckling and fracturing of masonry panels:

- flexible movement joints should be provided at the underside of each horizontal support member
- the masonry outer leaf should have a minimum two-thirds of its width supported securely by the concrete frame or a metal angle. See Figure 24 (water exclusion detail not included for clarity)
- appropriately detailed horizontal joint should be provided which can accommodate all movements anticipated at the joint, including deflection of substrate and the angle support system, as well as the limited compressibility of both the joint fillers and sealant
- additionally, horizontal movement joints should be capable of accommodating at least 1mm movement per continuous meter of vertical clay masonry
- vertical movement joints should be provided at corners, where appropriate
- the inner leaf should be adequately tied to the structural frame.

Figure 24: Masonry support

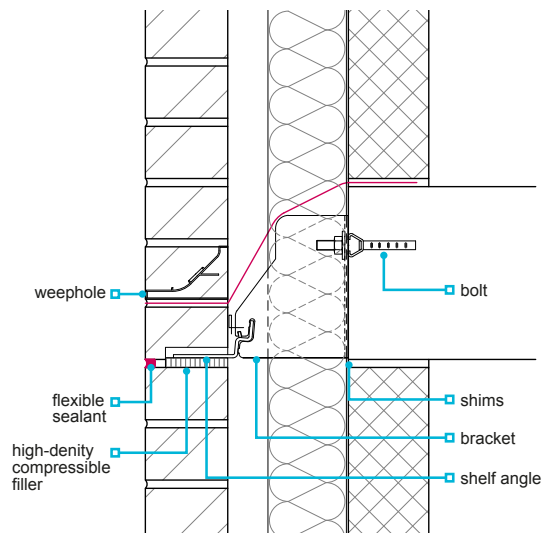

6.1.16.2 Joints

Joints between claddings and adjacent materials should:

- be detailed to be watertight under the particular exposure conditions of the site
- have provision for differential movement, where necessary.

6.1.16.3 Materials for cladding

Table 7: Materials for cladding

Component	Requirement	Notes
Tiles and slates	BS EN 1304, BS EN 490, BS EN 12326-1	Clay tiles for tile hanging, concrete tiles for tile hanging, slates for vertical slating
Timber boarding	BS EN 942	Timber should: <ul style="list-style-type: none"> comply with and be at least class J50 be a naturally durable species or pre-treated with preservative
Battens		Battens should be: <ul style="list-style-type: none"> of the size specified in the design pre-treated with preservative
Proprietary cladding systems	Technical Requirement R3	Satisfactory assessment by an appropriate independent technical approvals authority accepted by NHBC

Timber cladding should be in accordance with Chapter 3.3 Timber preservation (natural solid timber).

Prefabricated lightweight brick clad arches

Prefabricated lightweight brick clad arches comprising cement particle or fibre cement boards, injected polyurethane core and clay fired brick slips attached with epoxy adhesive for use as a decorative non load-bearing arch above openings in masonry cavity walls should:

- hold a satisfactory assessment by an appropriate technical approval's authority acceptable to NHBC
- be supported by a load-bearing lintel
- be installed in accordance with the manufacturer's instructions
- include a cavity tray over all openings (where the manufacturer's recommendations require a cavity tray to be located over prefabricated lightweight arches, a lintel with suitable profile and durability and proprietary stop ends and weepholes should be provided).

6.1.16.4 Vertical tile or slate cladding

Vertical tile or slate cladding to walls should:

- conform with Chapter 6.9 Curtain walling and cladding
- be fixed in accordance with the manufacturer's recommendations.

6.1.16.5 Stone veneer cladding systems

Stone veneer cladding systems should be in accordance with:

- BS 8298 when mechanically fixed
- Chapter 6.9 when used as a brick slip/rainscreen system.
- Technical Requirement R3 when adhesive fixed

6.1.17 DPCs and cavity trays

Also see: Chapters 6.2, 6.11 and BS 8215

DPCs and related components shall be provided to prevent moisture rising or entering the building. Issues to be taken into account include:

- 1) provision of DPCs and cavity trays
- 2) stepped cavity trays
- 3) parapet details.

6.1.17.1 Provision of DPCs and cavity trays

DPCs and flexible cavity trays should be of the correct dimensions to suit the detailed design.

High bond DPC can be used for applications including parapet walls, beneath copings and cappings.

High load DPC should be used where it will be subject to over three storeys of masonry.

The following materials are acceptable for use as DPCs:

Bitumen-based materials	BS 6398, BS EN 14967
Polyethylene (except as cavity trays in walls, below copings and in parapets)	BS 6515, BS EN 14909
Proprietary materials	Technical Requirement R3
Thermoplastics and Elastomers	BS EN 14909

Table 8: Positions where DPCs and cavity trays are generally required

Location	Provision of DPCs and cavity trays
Base of walls, piers, etc	A DPC should be provided a minimum 150mm above adjoining surfaces and linked with the DPM in solid floors
Base of partitions built off oversite where there is no integral DPM	The DPC should be the full width of the partition
Base of wall built off beam, slab, etc	Detail to prevent entry of damp by driving rain
Parapets	Beneath coping, and 150mm above adjoining roof surface to link with the roof upstand
In cavity walls over openings, air bricks, etc	A cavity tray should be provided to direct any water that enters the cavity to the outside. The cavity tray should fully protect the opening
At the horizontal abutment of all roofs over enclosed areas and balconies to walls	A cavity tray should be provided 150mm above any adjoining roof or balcony surface. The tray should be lapped over any roof upstand or flashing to ensure water penetrating into the cavity does not enter the enclosed area
At sloping abutments of all roofs over enclosed areas to cavity walls	Preformed stepped cavity trays should be provided above the roof surface and linked to the roof upstand or flashing to ensure any water penetrating into the cavity does not enter the enclosed area
Doorsteps	A DPC should be provided behind a doorstep where it is higher than a wall DPC
Sills	Where precast concrete or similar sills incorporate joints or are of a permeable material, a DPC should be provided beneath them for the full length and be turned up at the back and the end of the sill
Jambs in cavity	The reveal should be protected throughout its width by a continuous DPC. The width of the DPC should be sufficient to be fixed to, or overlap, the frame and fully protect the reveal For very severe exposure conditions, rebated reveal construction or a proprietary closer, suitable for the conditions, should be used
Stone heads	Where precast concrete or similar stone heads incorporate joints or are made of a permeable material, a DPC should be provided beneath them for the full length and built into, or fixed to, the inner leaf wall
Above gas membranes bridging the cavity	Where gas membranes bridge the cavity, a cavity tray should be provided. Cavity trays should be sealed to the gas membrane in accordance with the manufacturer's instructions to prevent capillary damp ingress at the joint

Figure 25: Low level DPC

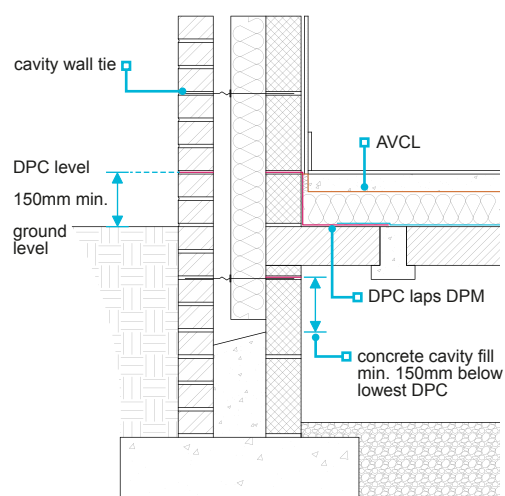

Figure 26: Cavity tray to air brick

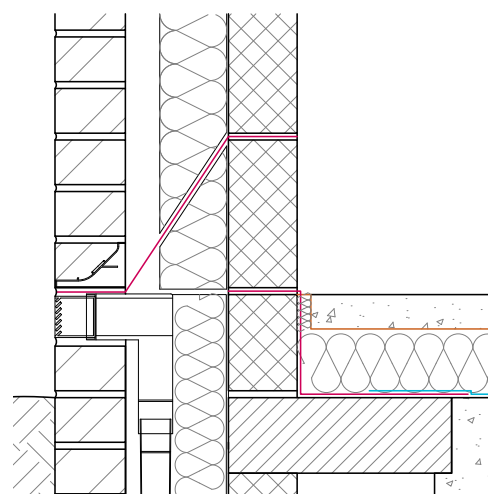

Figure 27: Cavity tray to inset meter box

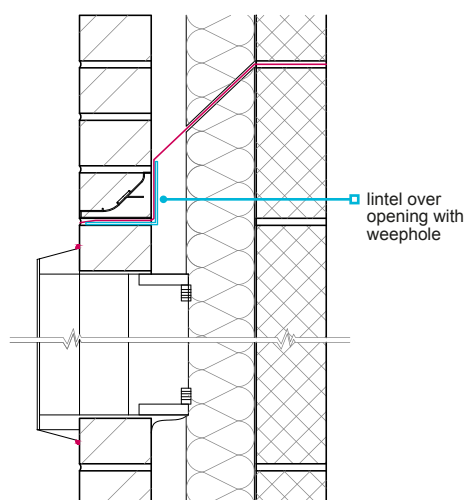
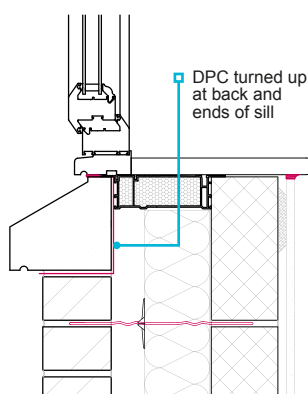

Figure 28: DPC to stone sill



Cavity trays

Cavity trays should be provided at all interruptions to the cavity (eg window and door openings, and air bricks) unless otherwise protected (eg by overhanging eaves). Cavity trays should:

- meet the requirements of BS EN 14909 and hold certification from an appropriate independent technical approvals authority accepted by NHBC confirming suitability for use as a cavity tray
- provide an impervious barrier and ensure that water drains outwards
- always be provided with stop ends where discontinuous
- project sufficiently beyond the lintel ends and cavity face of the cavity closer or vertical DPC, forming a stop end in the nearest naturally occurring perpend joint
- be laid on a wet, even bed of mortar, free from projections which could puncture or adversely affect the DPC material, with masonry above bedded on wet mortar to ensure the DPC material is 'sandwiched'
- provide drip protection to door and window heads
- have a 140mm minimum upstand from the inside face of the outer leaf to the outside of the inner leaf
- not be low-density polyethylene (LDPE) to BS 6515
- be shaped to provide 100mm minimum vertical protection above points where mortar droppings could collect
- be provided where the cavity is bridged by air bricks, etc and the DPC should extend 150mm beyond each side of the bridge
- where not otherwise protected (eg by a roof at an appropriate level), be provided over meter boxes
- be in one continuous piece or, where necessary, have sealed or welded joints which are provided with rigid support and lapped at least 100mm
- be preformed where used at complicated junctions
- be used in accordance with the manufacturer's recommendation.

On sites where radon or hazardous ground gases are present and cavities need to be sealed, it is still necessary to ensure downward movement water within the cavity is deflected from the cavity to the outside. To ensure all relevant functional performance requirements of DPC's, cavity trays and gas barriers are met when such site conditions occur and that all products are compatible and detailed to ensure continuity, specialist advice should be sought. Further guidance can be found in Clause 4.1.7.

Figure 29: Cavity tray to openings

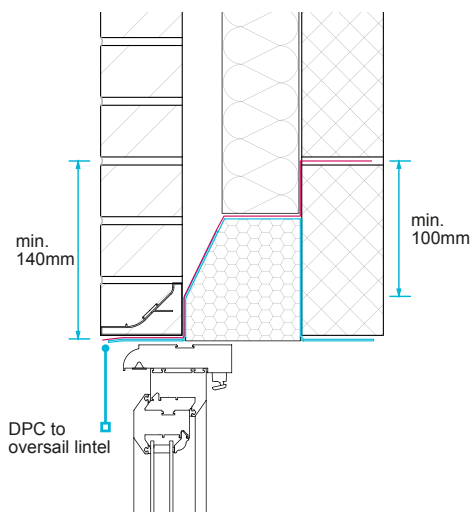
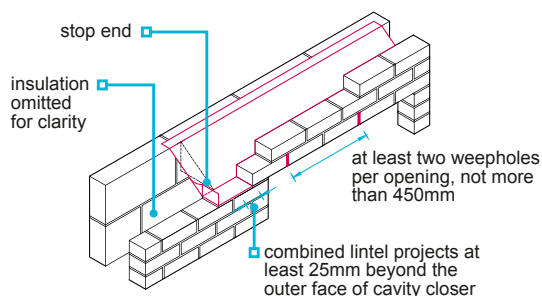

Figure 30: Cavity tray stop ends and weepholes



Stop ends should be of sufficient height to contain water and discharge it safely, and be the height of a full brick perpend. Stop ends may be formed by:

- turning up the end of a flexible sheet damp proof material, or
- proprietary plastic stop ends (where the lintel is a type that has the necessary corrosion protection and profile, and separate protection is not required by the manufacturer), specified to suit the profile and adhered to the surface of the lintel in accordance with manufacturer's instructions.

The upstand part of the cavity tray should be returned into the inner leaf unless it is stiff enough to stand against the inner leaf without support. In Scotland, Northern Ireland, the Isle of Man and areas of very severe exposure to driving rain, the upstand part of the damp proof protection should be returned into the inner leaf of masonry (this does not apply at sloping abutments).

Where fair faced masonry is supported by lintels:

- weepholes should be provided at a maximum of 450mm intervals
- each opening should have at least two weepholes
- cavity trays or combined lintels should have stop ends.

Where the lintel does not require a DPC, it should:

- have a suitable profile and durability
- give complete protection to the top of the reveal and vertical DPC, where provided.

Where the cavity has fully filled insulation, a cavity tray should be used above the highest insulation level, unless the insulation is taken to the top of the wall and is in accordance with the manufacturer's recommendations.

Weepholes

Weepholes in cavity walls should be the equivalent of a full brick perpend joint, eg 65mm x 10mm, where exposed within the cavity. The size of the discharge opening in proprietary weepholes may be smaller, provided it is designed to discharge any water collected, safely. The end of the weephole within the cavity should be kept clear of mortar droppings.

Weepholes to cavity walls should be provided:

- to cavity trays above openings and penetrations through the wall (such as sub-floor vents, ducts or flues), at least two per opening at not more than 450mm centres
- at least one to the bottom tray in a series of stepped cavity trays, eg at pitched roof abutments
- on cavity trays in parapet walls or at horizontal roof abutments at not more than 1m centres.

Figure 31: Weepholes to inset gas meter box

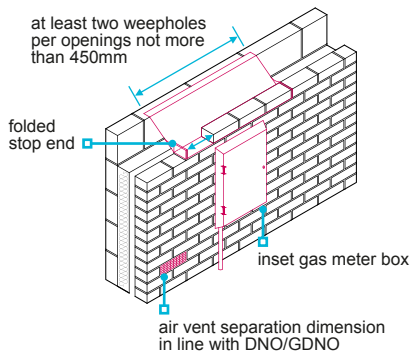

For guidance on weepholes to rendered walls, see Chapter 6.11 Render.

Where masonry cladding is installed to timber framed structures, the guidance on design of weep vents in Chapter 6.2 External timber framed walls should be followed.

Complicated junctions

Changes of direction of a cavity tray or interfaces with other elements in the cavity are more complicated than simple joints and would involve complex bending, folding, or cutting and sealing if fabricated on site. At complicated junctions, clear drawings and the design should be provided, and preformed cavity trays used.

Complicated junctions include:

- pitched roof abutments (ie, stepped trays)
- steps in horizontal level
- internal corners
- external corners
- t-junctions (ie, intersection of parapet wall)
- door thresholds (in conjunction with gas membranes, flat roofing detailing, etc)
- penetrations in horizontal cavity tray arrangements (ie, telescopic vents, services, etc)
- interfaces with windposts, balcony supports, balustrading or guarding.

Site folding of internal and external corners may be permitted where the quality of the installation is of the highest standard and installed in accordance with manufacturers recommendations.

Where preformed cavity trays are used, the joint with the flexible DPC cavity tray should be sealed in accordance with the manufacturer's recommendations.

Horizontal DPCs

DPCs should:

- be the correct width
- lap the DPM where appropriate
- be laid on a wet, even bed of mortar, free from projections which could puncture or adversely affect the DPC material, with masonry above bedded on wet mortar to ensure the DPC material is 'sandwiched'
- at ground level, generally be a minimum of 150mm above finished ground or paving level
- lapped a minimum of 100mm at joints, or be sealed or welded, where intended to prevent rising damp
- be considered in the design of masonry wall panel
- be used in accordance with the manufacturer's recommendations.

The concrete fill in a cavity wall should stop at least 225mm below the base DPC. This may be reduced to 150mm where special foundations, such as rafts, are used.

Figure 32: Concrete cavity fill

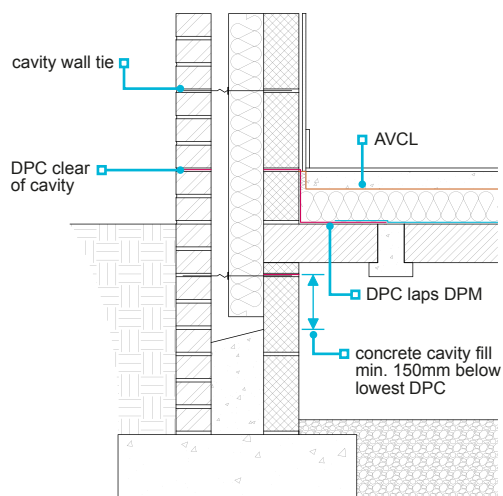
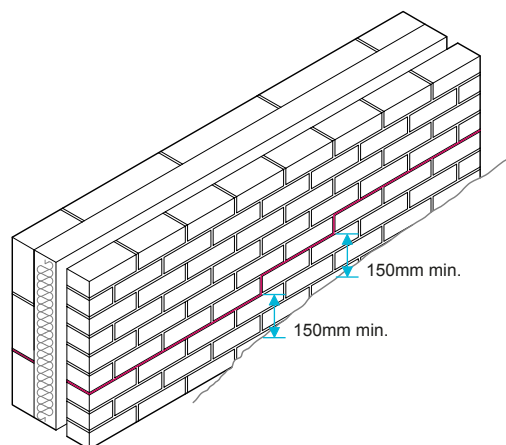

Figure 33: Stepped horizontal DPC



Where a jointed or permeable sill is used, a DPC should be:

- placed between the sill and the outer leaf
- turned up at the back and ends of the sill.

At sills where there is:

- a DPC, it should be lapped with the reveal DPC
- no DPC, the vertical DPC should be continued 150mm below the sill level.

Special DPC detailing may be required at accessible thresholds.

Vertical DPCs

A separate vertical DPC should be provided around openings, extend to the underside of the lintel, and:

- be of a proprietary material assessed in accordance with Technical Requirement R3, or
- 150mm wide DPC material, nailed to the full height of the frame, and protrude 25mm into the cavity.

A fillet joint of sealant should not be considered a substitute for good workmanship or DPCs. However, a bead of mastic should be used around openings.

Cavity trays and insulation material

Where fully filled or partial fill insulation is installed, particular care needs to be taken to ensure the insulation continuity is maintained around the cavity tray.

Connections with flashings

Where flashings link with DPCs (eg horizontal or preformed stepped cavity trays), 25mm of mortar below the DPC should also be raked out as the work proceeds to allow for the flashing to be tucked in.

Figure 34: DPC to flashing interface

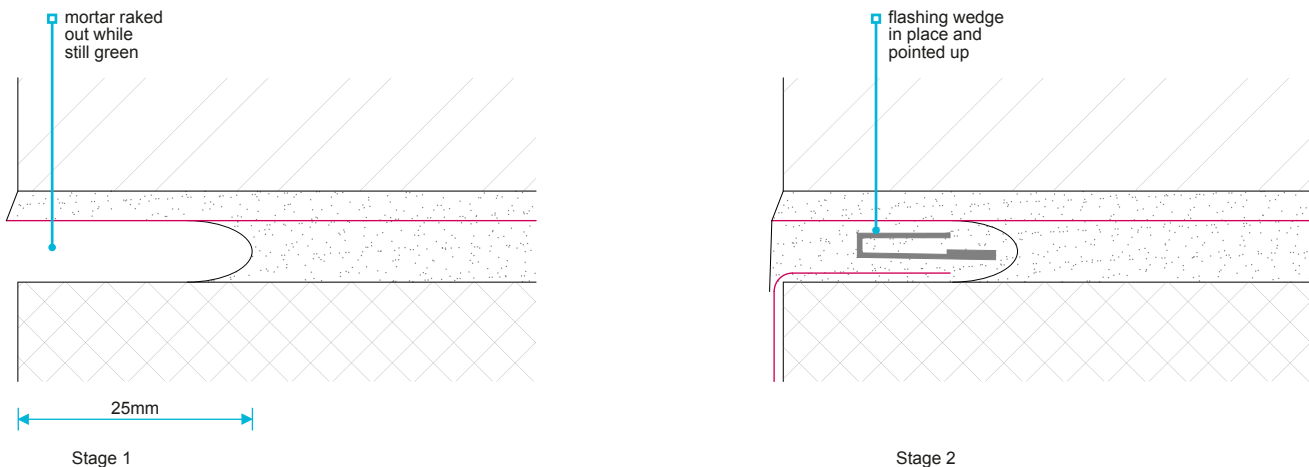

Joints between the masonry and flashing should be pointed with cement mortar or suitable exterior grade sealant (polysulfide or neutral-cured silicone) in accordance with the manufacturer's recommendations.

Arches

At openings with an arched head or circular windows, it is not practical to shape a flexible DPC and achieve the correct protection, and a preformed cavity tray should be used.

6.1.17.2 Stepped cavity trays

Where the roof abuts at an angle with the wall, preformed stepped cavity trays should be provided.

To minimise the risk of water ingress below the abutment, preformed stepped cavity trays:

- should be provided where a roof abuts a cavity wall above an enclosed area, eg an attached garage
- should have two stop ends at the lowest cavity tray and a weephole to allow water to drain from the cavity
- are not necessary where the roof is not over an enclosed area, eg open carport and open porch.

Figure 35: Stepped cavity trays

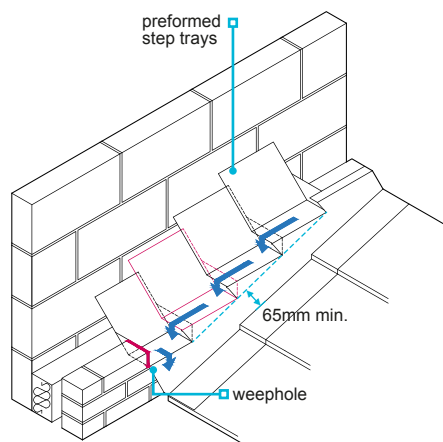

Preformed stepped cavity trays should be installed in accordance with the manufacturer's recommendations and positioned:

- to suit the dimension of the flashing (which should be in accordance with the manufacturer's recommendations or a minimum width of 65mm)
- so that the stepped cavity tray cannot discharge behind flashing (where it is necessary to cut bricks or blocks, the bond should be maintained in the following joint).

6.1.17.3 Parapet details

Parapet walls should have:

- a DPC under the coping, and a DPC tray starting 150mm minimum above the roof
- coping throating which is 30mm clear of the brickwork
- copings that comply with BS 5642 Parts 1 and 2.

DPCs in parapet walls should be:

- supported over the cavity to prevent sagging below copings
- specified to achieve a good key with the mortar
- fully bedded in mortar
- sealed to prevent water seeping through the joints.

Figure 36: Parapet walls

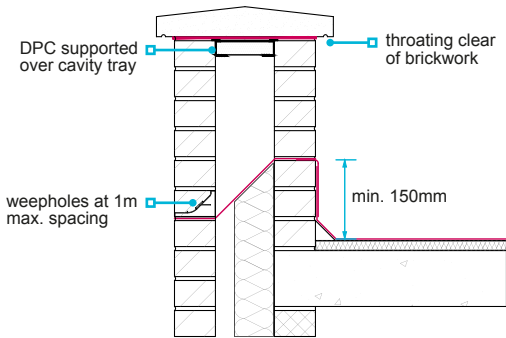

Figure 37: Copings/cappings to parapet walls

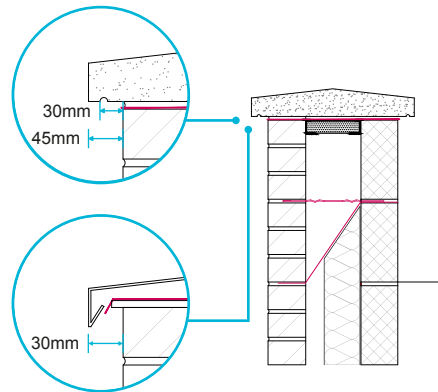
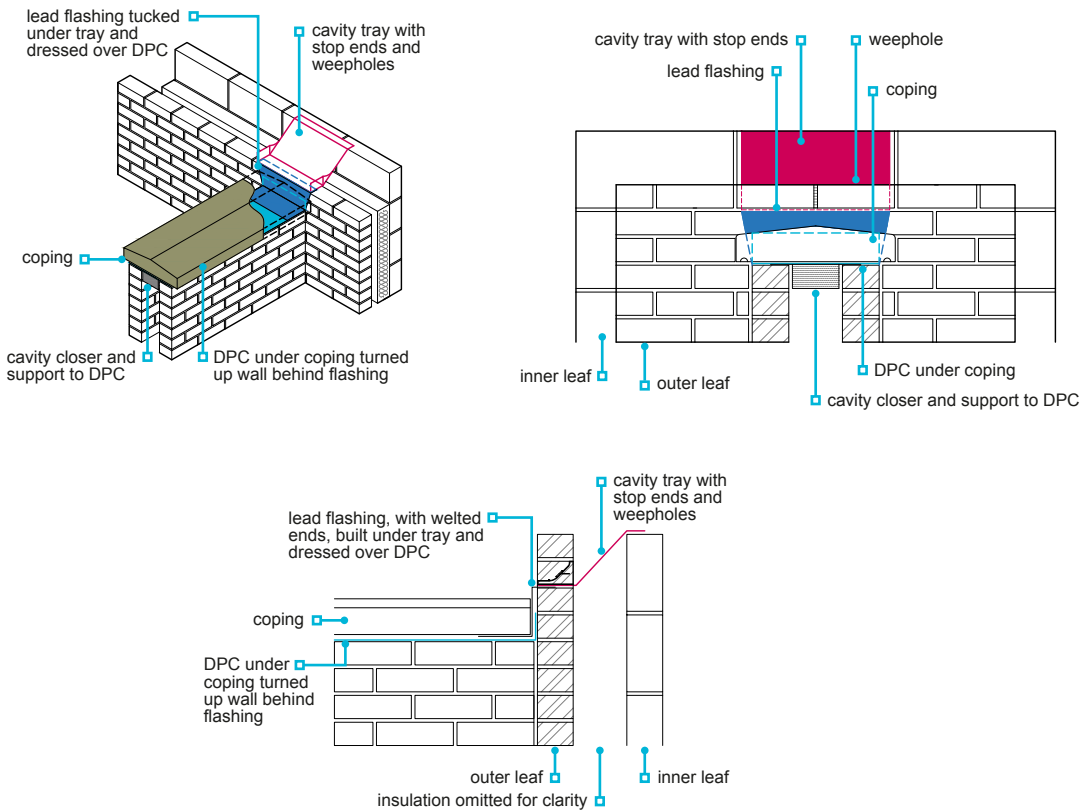

Figure 38: Parapet to external wall junction — DPC/cavity tray arrangement



6.1.18 Wall ties, bed joint reinforcements and windposts

Wall ties, bed joint reinforcements and windposts of the correct type shall be installed where required, and be suitable for their intended use and location. Issues to be taken into account include:

- 1) position
- 2) ties for partial fill insulation
- 3) cavity widths of over 100mm.

Wall ties should:

- be in accordance with BS EN 845-1 or Technical Requirement R3
- be of the type specified in the design
- be long enough to be embedded a minimum of 50mm into each leaf
- be stainless steel or non-ferrous materials in accordance with Technical Requirement R3
- be spaced above and below the DPC in accordance with Table 9
- be of the type or classification that is appropriate for the end use (including cavity width) and geographical location
- be specified to accommodate movement where required by the design
- be used in accordance with the manufacturer's recommendations.

Bed joint reinforcements should:

- be in accordance with BS EN 845-3 or Technical Requirement R3
- be of the type specified in the design
- be sufficiently wide so that minimum cover of 20mm is provided from the external face of masonry
- be stainless steel or non-ferrous materials in accordance with Technical Requirement R3
- have a minimum lap length of 225mm, and laps between lengths should always be staggered
- be used strictly in accordance with the manufacturer's recommendations.

Windposts should:

- be designed by an engineer in accordance with Technical Requirement R5
- comply with Clause 5.12 and Table 2 of PD 6697:2019 Recommendations for the design of masonry structures to BS EN 1996-1-1 and BS EN 1996-2
- be austenitic stainless steel (material reference 1 or 3, see Table 4) where connected to or embedded in an outer leaf of an external cavity wall in buildings exceeding three storeys
- be austenitic stainless steel (material reference 1, see Table 4) where used in aggressive environments eg coastal locations.

6.1.18.1 Position

Table 9: Spacing of wall ties

	Maximum horizontal spacing (mm)	Maximum vertical spacing (mm)
General wall area	900	450
Jamb openings, movement joints, etc	Within 225 of opening	Not more than 300 ⁽¹⁾
Top of gable walls	225 (parallel to the top of the wall)	Not more than 300 ⁽²⁾
Top and bottom of openings	450	N/A

Notes

1. Vertical spacing and number of ties may need adjusting to produce equivalent number of ties when using insulation boards.
2. Vertical spacing and number of ties may need adjusting to produce equivalent number of ties when using studded or spandrel panels.

Water should be prevented from crossing the cavity. Care should be taken to avoid:

- ties sloping down to the inner leaf
- drips being off-centre
- ties having mortar droppings on them.

Cavity walls should be coursed so that the wall tie is level or slopes outwards.

Figure 39: Wall tie locations

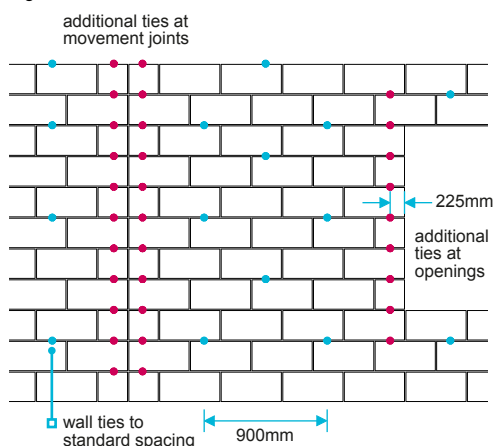

Figure 40: Wall tie embedment

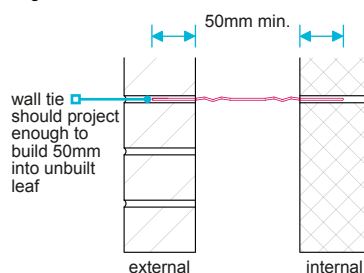
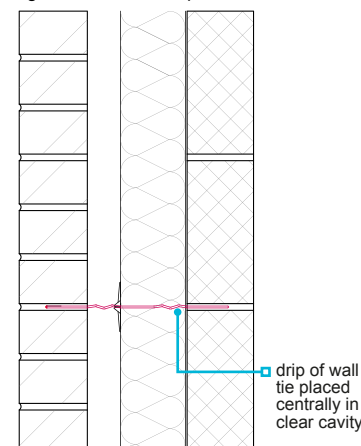

Figure 41: Wall tie to partial fill insulation



Wall ties should be:

- built in and not pushed into joints
- of sufficient length to achieve a minimum 50mm embedment into each leaf of masonry, allowing for normal tolerances in cavity width
- positioned so that the drip is centred in the clear cavity and faces downwards.

6.1.18.2 Ties for partial fill insulation

Where partial cavity fill insulation is being used, it should be held against the inner leaf by retaining devices, which may be clipped to the wall ties. Retaining devices should be:

- compatible with the wall ties
- used in accordance with Technical Requirement R3.

Where 1,200mm boards are used with partial fill cavities, the wall ties should:

- be spaced closer to provide adequate support and restraint
- be spaced at 600mm centres in rows ie, not staggered.

6.1.18.3 Cavity widths of over 100mm

Where cavity to masonry walls is to be 100-150mm, wall tie spacing in Table 9 may still be used in dwellings of up to three storeys high in sheltered and moderate exposure locations, provided they are of the right length with 50mm minimum embedment in the masonry.

Where dwellings are exposed to severe and very severe winds, including on exposed and elevated locations of over 150m above sea level as well as coastal locations, site-specific assessment of wall tie requirements should be undertaken. The wall tie spacing in Table 9 may still be acceptable, if used in conjunction with stiffer wall tie types — eg Type 1 or 2 in accordance with PD 6697.

6.1.19 Handling materials

Materials shall be handled in such a way as to ensure that the construction is neat, clean and undamaged upon completion.

Materials should be stored properly. Issues to be taken into account include the following:

- deliveries should be undertaken safely to protect both the operatives and materials only using pallets provided by the manufacturer
- stacks of bricks and blocks should be protected from rain and mud splashes, etc by covering them with waterproof covers
- a suitable level and safe place should be identified on each site for the masonry deliveries
- cement should be stored off the ground and protected from weather
- sand should be prevented from spreading and be protected so that it remains clean
- insulation materials should be handled and stored in accordance with the manufacturer's instructions. Normally, insulation materials should be protected from the weather.

Materials should be handled with care during construction to avoid damage and staining. Chipped or fractured bricks are not acceptable for facework.

Bricks that are tipped on delivery or moved about the site in dumper trucks often have a high degree of wastage.

The unloading of all bricks and blocks, especially facing bricks, should be:

- by mechanical means
- directly onto a firm level surface.

Unless bricks have been blended by the manufacturer, bricks from different batches should be mixed to avoid colour patching.

To reduce the risk of efflorescence, newly erected masonry should be covered. This also prevents the mortar being washed out of the joints by rain and stops masonry becoming saturated. Bricks and blocks that become excessively wet can suffer from:

- staining and efflorescence
- lack of mortar adhesion to mud-stained surfaces.
- increased drying shrinkage, with a greater risk of cracking

The work place should be kept clean to reduce mortar splashes to a minimum. Any accidental mortar smears should be lightly brushed off the face after the mortar has taken its first set.

6.1.20 Protection of the works during construction

Also see: Chapter 3.2

Precautions shall be taken to protect walls from damage during construction.

Issues to be considered include:

- 1) cold weather working
- 2) hot weather working
- 3) excessive rain working.

6.1.20.1 Cold weather working

Freshly laid mortar may fail where it freezes.

The use of air-entraining agents in cold weather gives better frost resistance to set mortar but does not aid the set. The use of accelerating admixtures and other admixtures should not:

- be relied on as an anti-freeze precaution
- contain calcium chloride.

The setting times of additives should be checked and adhered to in accordance with the manufacturer's recommendations. Cold weather retarders increase setting times.

In cold weather:

- brickwork and blockwork should not be built when the air temperature is below 3°C and falling
- work can resume when the temperature is 1°C and rising, with the expectation the temperature will exceed 3°C
- walls should be protected from frost until the mortar has set sufficiently to resist frost damage
- covers should be provided to form a still air space to insulate the wall
- walling damaged by frost will not regain strength and should be taken down and rebuilt when conditions improve.

Note

1. Thin joint mortars that can be shown to have been successfully tested for use down to 0°C are acceptable when the temperature is 0°C and rising. The mortar should be used strictly in accordance with the manufacturer's instructions and Chapter 3.2 Cold weather working.

6.1.20.2 Hot weather working

In very hot weather above 30°C, the main concern is the rate that water is removed from the mortar either by suction of the warm masonry or evaporation. The mortar will also tend to lose its plasticity at a faster rate due to the evaporation of the water from the mix.

Mortar mixed at high temperatures may have a higher water content, a lower air content and a shorter board life. The quality of the bond between the mortar and the brick or block is dependent on having the correct amount of water, so this bond may be affected.

To reduce the impact of higher temperatures:

- store bricks and blocks in the shade to help control heat gain
- spraying with modest amounts of clean water can keep their temperature down and stop the suction, but do not soak them
- mixing equipment can be shaded from direct sunlight prior to use
- mortar tubs and mortar boards should be rinsed with cool water before coming into contact with the mortar
- where ready-to-use mortar is being stored on site, it is important to keep it well covered in the tub
- dry silo mortar — where the dry sand and cement mortar is stored on site in a hopper and mixed with water on demand, this offers the added advantage of being able to mix small batches which can be used up quickly.

In dry hot weather, absorbent clay masonry units may be wetted by lightly spraying to reduce suction. Care should be taken not to over-wet units. Low absorption units such as engineering bricks should not be wetted.

Newly built masonry should be protected with suitable material ie, hessian or sheeting, to insulate and prevent drying out too quickly. Hessian should not be wetted and laid dry.

6.1.20.3 Excessive rain working

Bricks or blocks should not be laid in excessive wet conditions.

New brickwork and blockwork should be completely covered to protect it from the elements.

If brickwork and blockwork is exposed to water for a prolonged period of time, the risk of leaching, cement residues and efflorescence will increase.

Protection of cavity walls during construction

Masonry cavity walls should be protected whenever work stops, eg for inclement weather or overnight. The tops of both leaves, as well as the cavity and any insulation, should be covered with sacking or plastic sheet and appropriately secured in place.

6.1.21 Further information

- *BS 8215 — Code of practice for design and installation of damp-proof courses in masonry construction*
- *PD 6697 — Recommendations for the design of masonry structures to BS EN 1996-1-1 and BS EN 1996-2*



Chapter 6.2



External timber framed walls

This chapter gives guidance on meeting the Technical Requirements for external walls of timber framed homes up to seven storeys high, substantially timber framed homes and timber wall panels.

6.2.1	Compliance	02
6.2.2	Provision of information	02
6.2.3	Design checking and certification	02
6.2.4	Load-bearing walls	03
6.2.5	Fixing the frame	05
6.2.6	Nails and staples	06
6.2.7	Sheathing	06
6.2.8	Differential movement	07
6.2.9	Fire resistance	12
6.2.10	Protection from moisture	13
6.2.11	Timber preservation	15
6.2.12	Air and vapour control layers	15
6.2.13	Breather membranes	16
6.2.14	Wall ties and fixings	16
6.2.15	Insulation	17
6.2.16	Further information	17

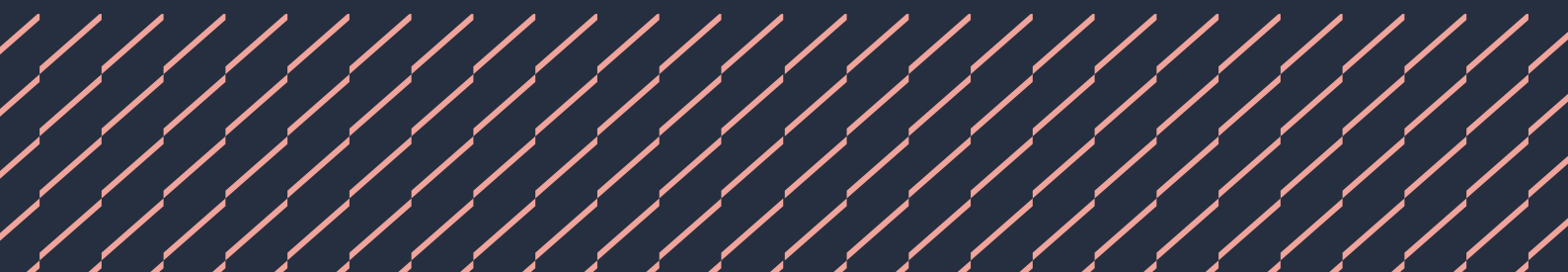

Figure reference table

Figure Reference Table 6.2

Fig No	Title/Description	Clause	Page
Figure 1	Timber frame wall panel	6.2.4.1	3
Figure 2	Sole plate foundation overhang	6.2.4.3	4
Figure 3	Sole plate foundation set back	6.2.4.3	4
Figure 4	Permanent structural packing under each stud	6.2.4.4	4
Figure 5	Bedding of sole plate on mortar	6.2.4.4	5
Figure 6	Double sole plate sandwich	6.2.4.4	5
Figure 7	Sole plate anchor brackets	6.2.5	6
Figure 8	Hold down straps built into masonry cladding	6.2.5	6
Figure 9	Platform timber frame floor zone	6.2.8	8
Figure 10	Window head and sill with masonry cladding	6.2.8	8
Figure 11	Movement allowance at window sill with masonry cladding	6.2.8	8
Figure 12	Movement allowance at window head with masonry cladding	6.2.8	8
Figure 13	Movement allowance at window head and lintel with masonry cladding	6.2.8	8
Figure 14	Lightweight cladding window head	6.2.8	9
Figure 15	Lightweight cladding window sill	6.2.8	9
Figure 16	Movement allowance at roof to vertical abutment — before movement	6.2.8	9
Figure 17	Movement allowance at roof to vertical abutment — after movement	6.2.8	9
Figure 18	Timber frame interface with concrete or masonry communal areas — before movement	6.2.8	9
Figure 19	Timber frame interface with concrete or masonry communal areas — after movement	6.2.8	9
Figure 20	Movement allowance at roof eaves	6.2.8	10
Figure 21	Movement allowance at roof verge	6.2.8	10
Figure 22	Movement allowance at service penetrations through masonry cladding	6.2.8	10
Figure 23	Drive through section details	6.2.8	10
Figure 24	Drive through Section A-A	6.2.8	10
Figure 25	Drive through Section B-B	6.2.8	10
Figure 26	Floor zone movement gap with lightweight cladding	6.2.8	11
Figure 27	Movement gaps at the junction of lightweight and masonry cladding	6.2.8	11
Figure 28	Balcony abutment — lightweight cladding	6.2.8	11
Figure 29	Balcony abutment — lightweight cladding	6.2.8	11
Figure 30	Balcony abutment — masonry cladding	6.2.8	11
Figure 31	Balcony abutment — masonry cladding	6.2.8	11
Figure 32	Slotted holes in balcony support brackets	6.2.8	11
Figure 33	Sliding movement joint in balcony support bracket	6.2.8	11
Figure 34	Juliette balcony support fixed to masonry cladding	6.2.8	11
Figure 35	Flat roof to masonry abutment movement detail	6.2.8	11
Figure 36	Fire-stopping and compartmentation at compartment wall/roof junction	6.2.9.1	12
Figure 37	Horizontal cavity barrier protected with DPC	6.2.9.1	12
Figure 38	Vertical cavity barrier protected with DPC	6.2.9.1	12
Figure 39	Window head detail with cavity tray and weepholes	6.2.10.3	14
Figure 40	Checked rebate at window reveal in areas of severe or very severe exposure	6.2.10.3	14
Figure 41	Lowest timber at least 150mm above external ground level	6.2.10.3	14
Figure 42	Lowest timber at least 75mm above external ground level	6.2.10.3	14
Figure 43	Breather membrane laps	6.2.13	16
Figure 44	Breather membrane lapped over sole plate	6.2.13	16
Figure 45	Insulation between external wall studs	6.2.15	17

6.2.1 Compliance

Also see: Chapter 2.1

External timber framed walls shall comply with the Technical Requirements.

External timber framed walls that comply with the guidance in this chapter will generally be acceptable. For guidance on internal walls and floors within timber frame buildings, see Chapters 6.3 Internal walls and Chapter 6.4 Timber and concrete upper floors.

Where the components of the timber frame cannot be inspected on site (eg closed panels or fully fitted out volumetric units), the system should be subject to review by NHBC. Please refer to the NHBC Accepts website at www.nhbc.co.uk/builders/products-and-services/techzone/accepts.

6.2.2 Provision of information

Designs and specifications shall be produced in a clearly understandable format, include all relevant information and be distributed to all appropriate personnel.

Clear and fully detailed drawings should be available on site to enable work to be carried out in accordance with the design. Design and specification information should be issued to site supervisors, relevant specialist subcontractors and suppliers, and include the following:

- a full set of drawings
- materials specification
- the position and materials for cavity barriers in accordance with relevant Building Regulations
- fixing schedules
- manufacturers' recommendations relating to proprietary items.

The fixing schedule should detail every connection which is to be made on site, including those for structural connections, framing, wall ties, breather membranes, sheathing and air and vapour control layers (AVCL), and should show as appropriate:

- number and spacing of fixings
- size and type of fixing, including material and corrosion protection
- method of fixing, eg skew nailing.

Further guidance on the contribution of plasterboard to racking resistance can be found in Clause 6.2.7. Where wall design relies on plasterboard to take racking forces, the design should:

- clearly define those walls
- include the type and spacing of fixings required.

6.2.3 Design checking and certification

Design of the superstructure shall be adequately checked.

Homes with a timber frame superstructure require certification confirming that the design has been checked by an NHBC-approved timber frame certifier.

The timber frame certifier should:

- be listed on NHBC's list of timber frame certifiers
- be a suitably qualified civil or structural engineer with a minimum of three years' experience in timber frame construction
- not be the designer of the timber frame nor be from the same practice
- complete and sign a certificate confirming assessment of structural adequacy for each specific project
- provide the registered builder with the completed and signed certificate.

The registered builder should ensure that the completed timber frame certificate is available on site for inspection by NHBC.

Contact NHBC Standards, Innovation and Research via OperationsSupport@nhbc.co.uk

- if you require contact details of frame certifiers, or
- to apply to become a timber frame certifier.

Alternatively, timber frame superstructures from Gold level members of the Structural Timber Association Assure scheme, who have engaged Silver/Gold level structural designers and engineers, are acceptable without additional certification.

The registered builder should ensure that a letter from the manufacturer is available on site for inspection by NHBC.

Designs should be submitted to NHBC when proposed buildings are four storeys or more and the floor joists are solid timber.

6.2.4 Load-bearing walls

Also see: Chapter 6.3, Structural Timber Association Advice Note 4 Tolerances

Load-bearing timber framed walls shall be constructed to support and transfer loads to foundations safely and without undue movement. Issues to be taken into account include:

- | | |
|---|---------------------------------------|
| 1) timber elements | 5) fixing panels |
| 2) joints between panels and other elements | 6) timber frame erection tolerances |
| 3) positioning of sole plates | 7) support of prefabricated chimneys. |
| 4) packing under sole plates | |

6.2.4.1 Timber elements

Load-bearing timber framed walls should be in accordance with BS EN 1995-1-1, and take into account:

- wind loads
- roof loads
- floor loads
- cladding loads.

Structural timber components should be of a suitable strength class as specified by the designer to BS EN 338. Solid structural timber should be:

- machine graded to BS EN 14081, or visually graded to BS 4978 for softwoods or BS 5756 for hardwoods
- assigned a strength class based on BS EN 1912 when visually graded
- dry graded
- marked in accordance with BS EN 14081.

Further guidance on strength classes for certain timber species can be found in PD 6693.

Engineered wood products such as I-section or metal-web studs should be assessed in accordance with Technical Requirement R3.

Individual timber studs should have:

- a minimum width of 38mm
- a maximum spacing of 600mm, unless other adequate support is provided for wall boards and fixings.

Narrow or inaccessible gaps between studs which are difficult to insulate should be avoided.

Lintels and cripple studs should be provided at openings in load-bearing panels except where:

- the opening does not affect the stud spacing, or
- supported loads are carried by a ring beam or header joist.

Sheathing and associated fixings should be structurally adequate, and resist racking due to wind and other forces.

Where masonry cladding is used, additional studs may be required at openings and vertical movement joints to fix wall ties.

Multiple studs should be included to support multiple joists and other point loads, unless otherwise specified by the designer. Where head binders are not provided, joists and roof trusses, including girder trusses and other similar loads, should bear directly over studs.

6.2.4.2 Joints between panels and other elements

Wall panels should be:

- securely fixed together, and securely fixed to the floor and roof framing
- constructed to prevent buckling.

At joints between wall panels, sole plates and head binders should be provided to bind panels together. Joints in sole plates and head binders should:

- occur over a stud
- not coincide with joints between panels.

Figure 1: Timber frame wall panel

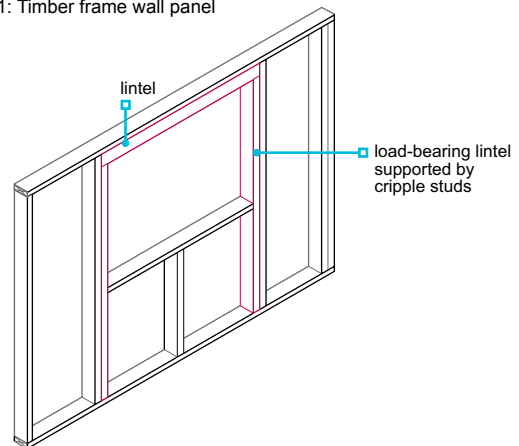

6.2.4.3 Positioning of sole plates

When setting out:

- the substructure should be correctly set out to receive the timber frame
- the timber frame should be checked to ensure that it is erected accurately, both horizontally and vertically
- the load from the frame should be supported as intended in the design
- protection should be provided where foundation ledges form moisture traps.

Figure 2: Sole plate foundation overhang

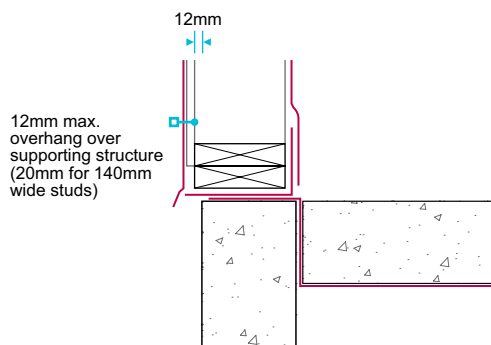
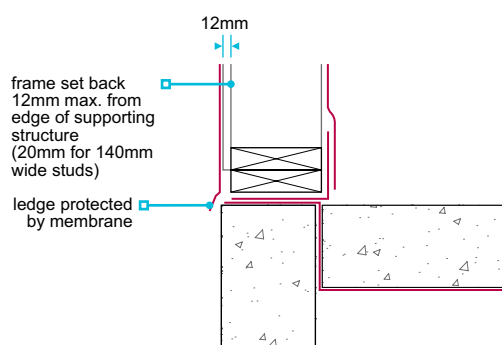

Figure 3: Sole plate foundation set back



6.2.4.4 Packing under sole plates

Where packing is required to ensure the timber frame or sole plate is level:

- permanent packing should be used for gaps less than 5mm
- grout and mortar should not be used for gaps less than 5mm
- hollow plastic packing with reduced bearing surfaces should not be used
- temporary spacers can remain in place provided they are durable and non-degradable.

Permanent packing should be:

- designed and approved by the timber frame designer to suit the horizontal and vertical loads on the sole plate
- at least the same plan area as the load points, eg studs or posts.

Packing exceeding 20mm should be agreed between the timber frame manufacturer's engineer and NHBC. The following methods are generally acceptable to NHBC for packing up to 20mm.

Permanent structural packing under sole plate

The sole plate should be levelled on temporary spacers.

When the first lift construction (including wall panels, first floor structure, or roof structure in a single storey building) has been erected, permanent packing should be placed under the sole plate, which can be:

- free-flowing non-shrinkable grout for the full length and width of the sole plate, or
- individual packers placed under each load point, eg stud or post.

Where grout is used as permanent structural packing, installation should be checked to ensure full bearing is achieved.

Figure 4: Permanent structural packing under each stud

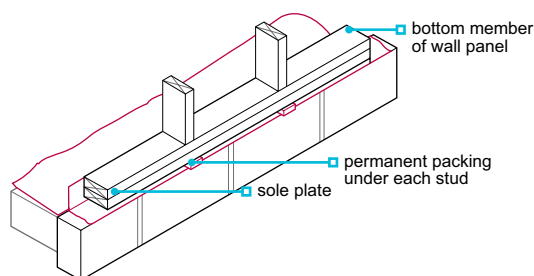

Bedding of the sole plate

The sole plate should be laid and levelled on a continuous bed of mortar prior to the erection of the wall panels.

The bedding should extend the full width of the sole plate. Care is needed to ensure that the bedding is not disturbed during the fixing of the sole plate.

Figure 5: Bedding of sole plate on mortar

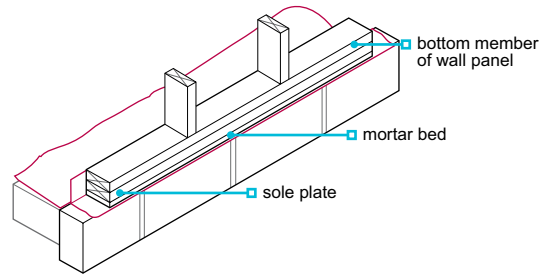

Double sole plate 'sandwich'

The lower sole plate should be fixed to follow the contours of the supporting structure.

The upper sole plate should then be fixed on top and levelled with temporary spacers inserted between the sole plates.

When the first lift construction has been erected, permanent packing should be inserted under each load point, eg stud or post.

Figure 6: Double sole plate sandwich

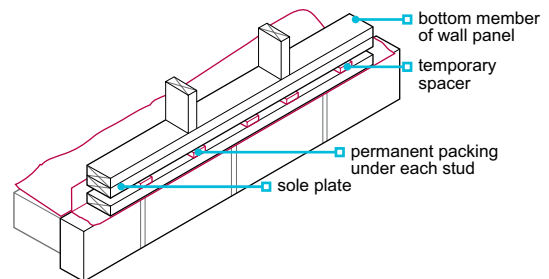

6.2.4.5 Fixing panels

The wall panels should be adequately fixed to the sole plate so that the frame can resist both lateral and vertical forces.

When fixing panels:

- fixings, including nailed joints and sheathing, should be as scheduled in the design
- they should be securely fixed together, to the floor and to the roof framing
- sole plates and head binders should be provided to bind the panels together.

6.2.4.6 Timber frame erection tolerances

Timber frame erection tolerances based on guidance from the Structural Timber Association will generally be acceptable.

6.2.4.7 Support of prefabricated chimneys

Prefabricated chimneys should be supported by:

- masonry cladding, or
- the timber frame, including any roof construction supported by the timber frame.

6.2.5 Fixing the frame

The timber frame shall be suitably fixed to the substructure.

Shotfiring

Where shotfiring:

- into masonry, solid concrete blocks should be specified as BS EN 771, with a minimum crushing strength of 7.3N/mm², and positioned to receive fixings
- the blocks in beam and block floors should be grouted
- care should be taken not to spall edges of masonry or slabs.

Anchoring

When anchoring the frame:

- the sole plate should be adequately anchored to the substructure so that the frame can resist both lateral and vertical forces
- care should be taken to avoid splitting timber plates or damaging the substructure.

Figure 7: Sole plate anchor brackets

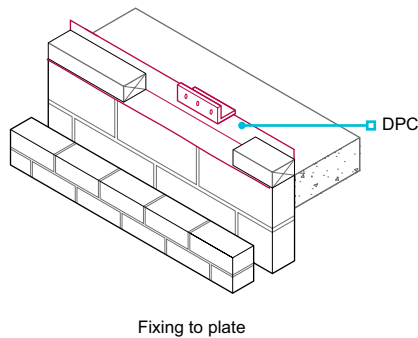
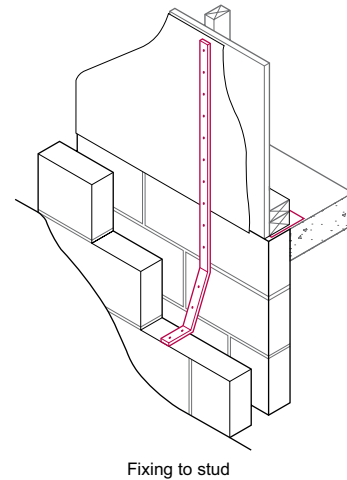

Figure 8: Holding-down straps built into masonry cladding



Holding-down devices should be durable, as detailed in the design and manufactured from:

- austenitic stainless steel to BS EN 10088-1, minimum grade 1.4301
- galvanised mild steel with zinc coating to BS EN ISO 1461, minimum coating 940g/m² on each side.

Sole plate anchors within the internal envelope should be galvanised mild steel, minimum coating Z275.

6.2.6 Nails and staples

Nails and staples shall be durable and of the correct type to provide adequate mechanical fixing.

Nails for fixing sheathing or timber should be either:

- austenitic stainless steel, or
- galvanised, or
- sherardised.

Staples for fixing breather membranes should be:

- austenitic stainless steel, or
- other material of similar strength and corrosion resistance.

6.2.7 Sheathing

Sheathing shall be durable and capable of providing structural resistance to racking.

The following materials are acceptable:

Plywood	BS EN 636-2S or BS EN 636-3S
Oriented strand board	BS EN 300 type OSB/3 or OSB/4
Moisture-resistant chipboard	BS EN 312 type P5 or P7
Medium board	BS EN 622-3 type MBH.HLS1 or MBH.HLS2
Impregnated soft board	BS EN 622-4 type SB.HLS
Proprietary sheathing materials	Technical Requirement R3 and used in accordance with the assessment

Plasterboard may contribute to racking resistance when used in accordance with PD 6693-1. Limitations or exclusions apply to walls that are not separating walls comprising two or more built-up layers of plasterboard having a minimum thickness of 30mm, and walls where plasterboard is combined with a wood-based sheathing on the same wall diaphragm.

6.2.8 Differential movement

Also see: Institution of Gas Engineers and Managers and Structural Timber Association Differential Movement in Platform Timber Frame

Timber structures shall account for differential movement between the timber frame wall and other building elements.

As the timber frame dries out, it will shrink and the overall height will reduce. The extent of the differential movement increases with the number of storeys, and will typically occur between the timber frame and other parts of the construction, including:

- door and window openings with masonry cladding
- eaves and verges with masonry cladding
- openings for drive-throughs with masonry cladding
- balconies (including Juliette balconies)
- service entries
- staircases and lift shaft enclosures (where they are not timber framed)
- the interface of the timber frame with any other construction at each floor level where cladding is fixed to the timber frame.

Where lightweight cladding is fixed to the timber frame, movement across floor zones should be allowed for in the cladding system and its supporting structure.

Movement joints should be provided to accommodate the expected movement. Joints should be detailed to:

- accommodate the expected amount of shrinkage or expansion safely
- provide an additional allowance for the residual thickness of any compressible filler materials after movement has occurred
- provide a weather-resistant and durable joint
- be protected by a cover strip where the movement gap/joint is expected to be more than 35mm.

Where compressible filler materials are specified, they should be specified based on the anticipated residual gap size after movement has occurred.

In the absence of project-specific calculations, gaps in accordance with Table 1 should be provided.

Table 1: Gap sizes with masonry cladding to accommodate differential movement

Gap location	Opening and closing gaps (mm)	
	Floor joists	
	Solid timber (mm)	Engineered I-joist (mm)
Eaves/verge	Add 5mm to gap dimension at level below	
Sixth floor	Specialist calculations to be submitted to NHBC ⁽²⁾	61
Fifth floor		53
Fourth floor		45
Third floor	45	35
Second floor	35	25
First floor	20	15
Ground floor ⁽¹⁾	5	5

Notes

1. Ground floor or lowest level of timber frame.
2. Calculations, where required, are to be based on BS EN 1995-1-1.

Table 1 is based on the following:

- the table allows for a 2mm thickness of compressible material in closing gaps. Check the manufacturer's product details
- timber components are not saturated and have normal moisture contents at the time of construction, eg less than 20%, and tight-jointed construction
- the ground floor is concrete. For ground floors of timber joists, add 15mm for solid timber and 10mm for engineered timber joists
- timber joist and ring beam/header joist have a maximum depth of 240mm
- timber frame floor cross-section is as shown below, with maximum 45mm deep timber plates/binders
- single head binder at the eaves. Maximum double sole plates
- outer leaf brickwork with expansion rates no greater than 2.5mm per storey
- brickwork up to five storeys, with lightweight cladding above five storeys
- lightweight cladding — floor-level joints must be 15mm for solid timber joists and 10mm for engineered timber joists.

Differential movement should be accommodated by the services where they:

- are within the timber frame construction/envelope and pass across floor zones
- pass through the external envelope.

Common details

The following sketches consider downward movement of the timber frame and upward brick expansion, taken as 2.5mm per storey of clay masonry. Cavity trays, cavity barriers, open perpend vents, etc are omitted for clarity.

Figure 9: Platform timber frame floor zone

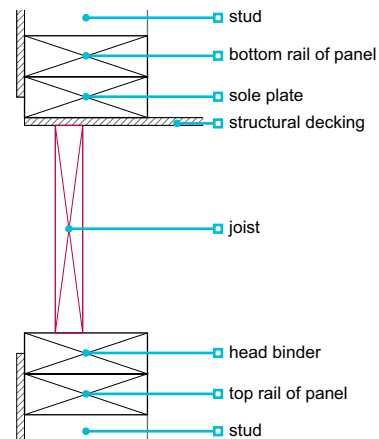

Timber frame construction on which Table 1 is based

Figure 10: Window head and sill with masonry cladding

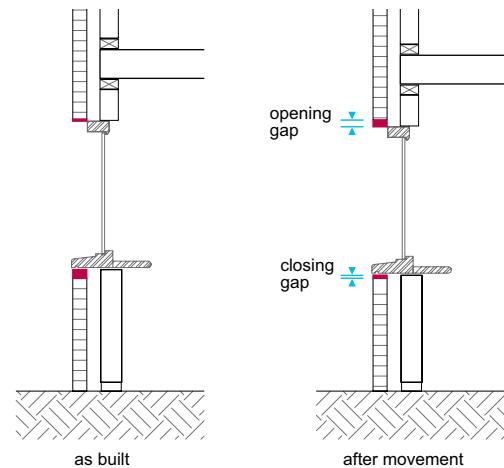

Figure 11: Movement allowance at window sill with masonry cladding

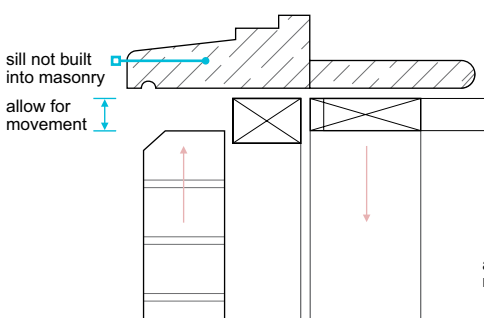

Figure 12: Movement allowance at window head with masonry cladding

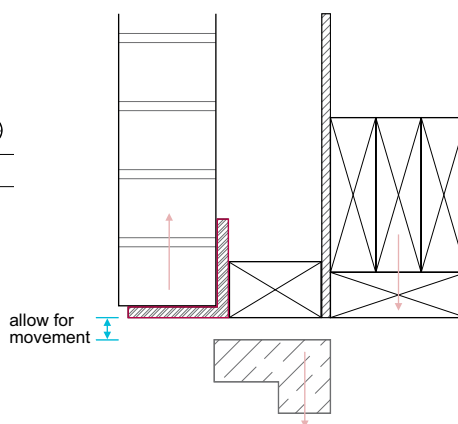

Figure 13: Movement allowance at window head and lintel with masonry cladding

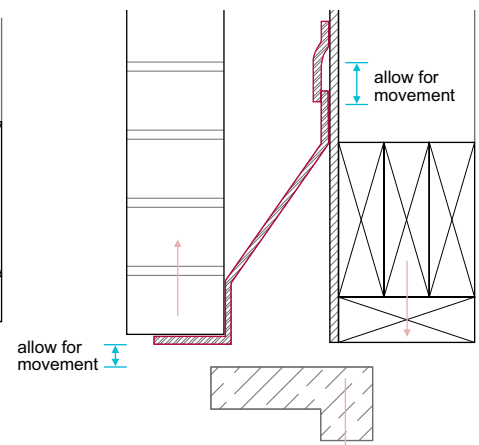

Figure 14: Lightweight cladding window head

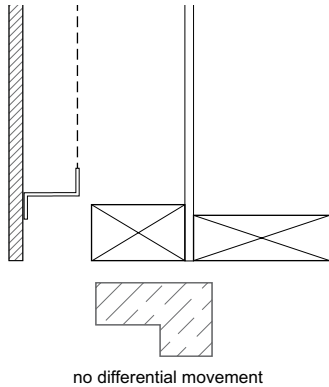

Figure 15: Lightweight cladding window sill

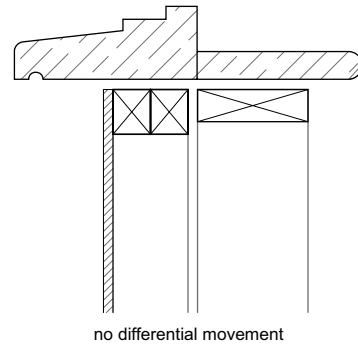

Figure 16: Movement allowance at roof to vertical abutment — before movement

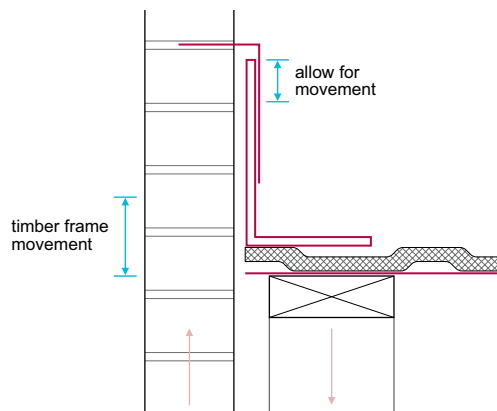

Figure 17: Movement allowance at roof to vertical abutment — after movement

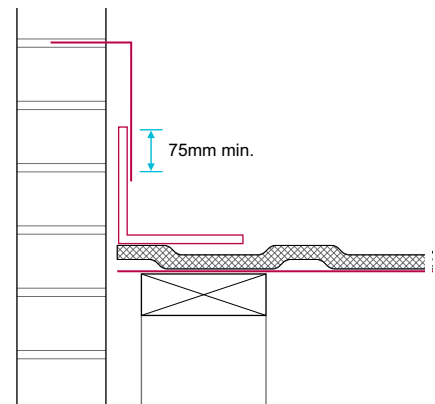

Figure 18: Timber frame interface with concrete or masonry communal areas — before movement

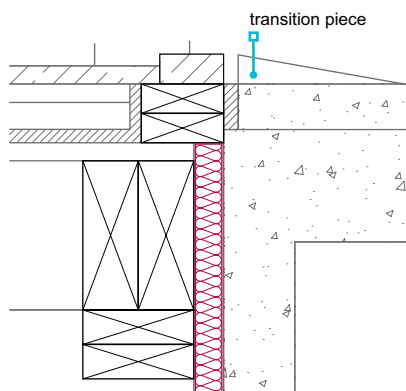
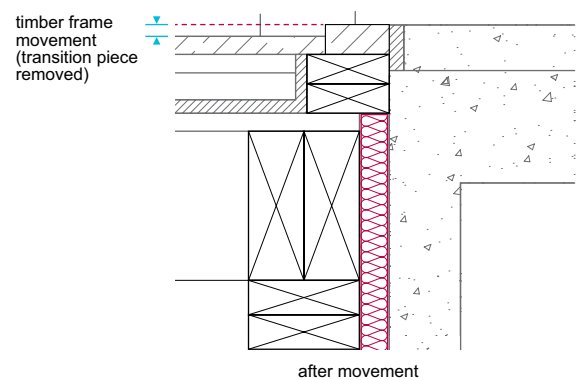

Figure 19: Timber frame interface with concrete or masonry communal areas — after movement



Eaves and verges

Where a movement gap provided between the top of an exterior cladding of masonry and the eaves or verge soffit exceeds 10mm and is not protected by a purposely designed overhang, the gap should be protected with a compressible filler material or mesh to prevent the entry of birds, etc. The filler material or mesh should be flexible so as not to inhibit the differential movement between the exterior cladding of masonry and timber frame. Where a flexible filler is used, it should be sized based on the anticipated residual gap after movement has occurred.

Figure 20: Movement allowance at roof eaves

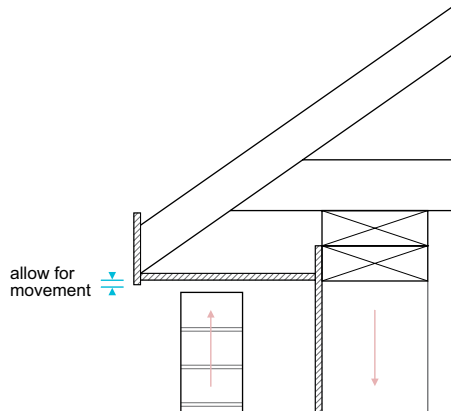
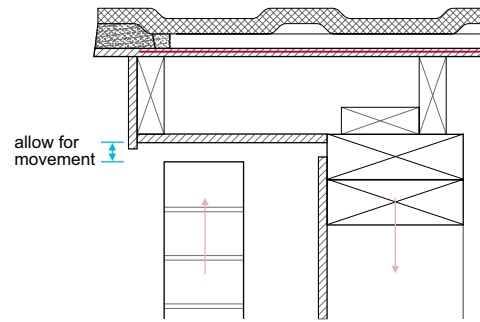
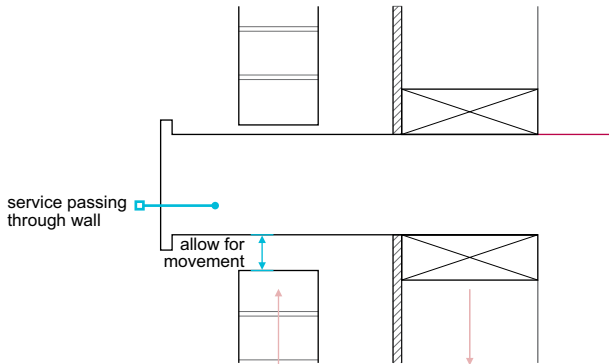

Figure 21: Movement allowance at roof verge



Services

Figure 22: Movement allowance at service penetrations through masonry cladding



Drive through

Figure 23: Drive through section details

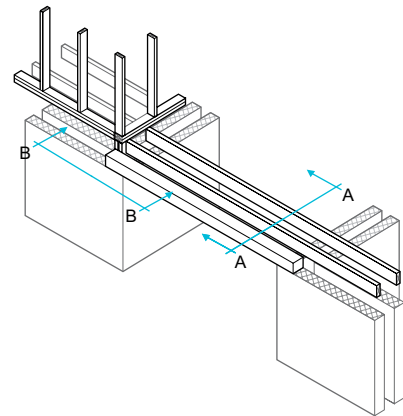

Drive through

Figure 24: Drive through Section A-A

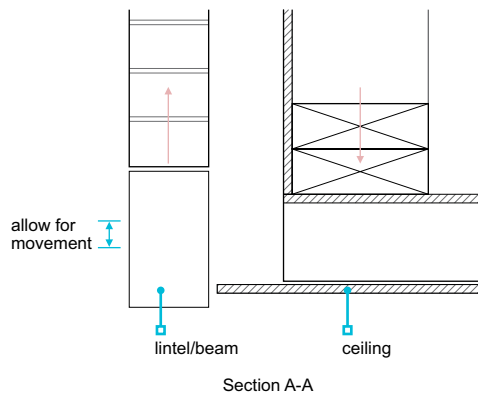

Figure 25: Drive through Section B-B

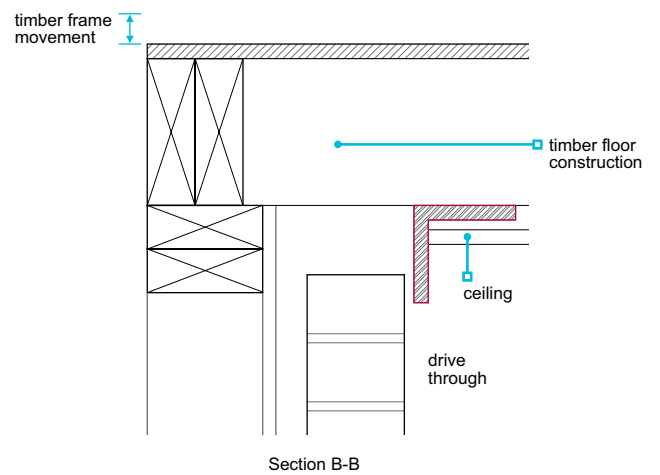
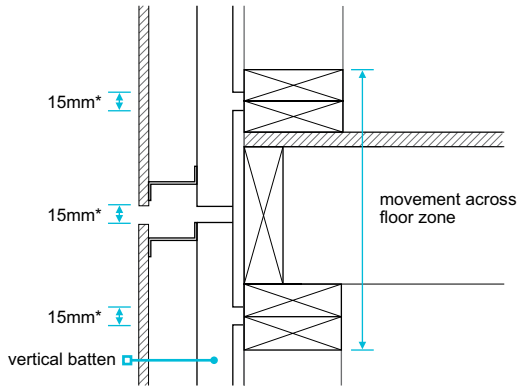

Figure 26: Floor zone movement gap with lightweight cladding



Lightweight cladding and masonry plinth

Figure 27: Movement gaps at the junction of lightweight and masonry cladding

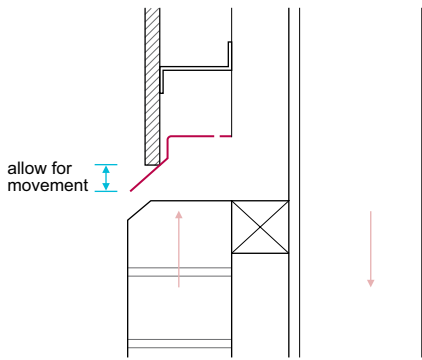

Figure 28: Balcony abutment — lightweight cladding

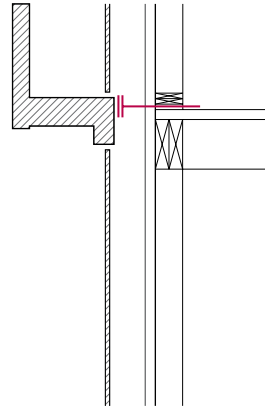

Figure 29: Balcony abutment — lightweight cladding

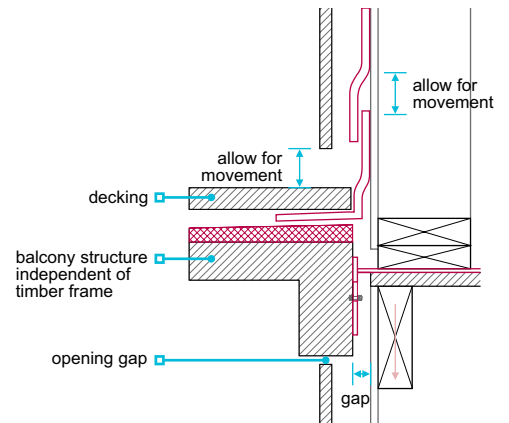

Figure 30: Balcony abutment — masonry cladding

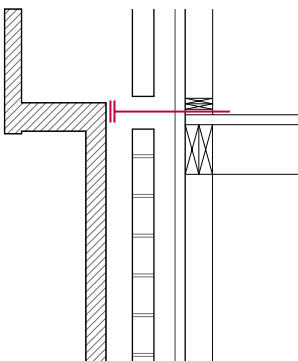

Figure 31: Balcony abutment — masonry cladding

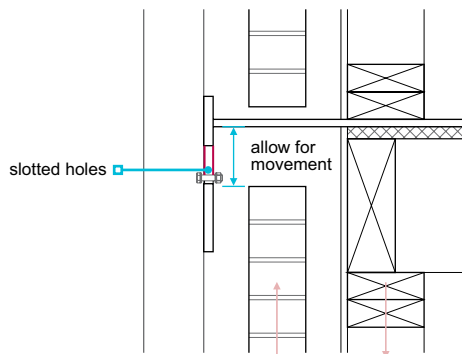

Figure 32: Slotted holes in balcony support brackets

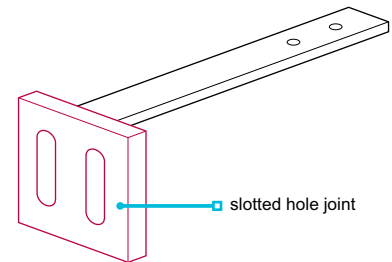

Figure 33: Sliding movement joint in balcony support bracket

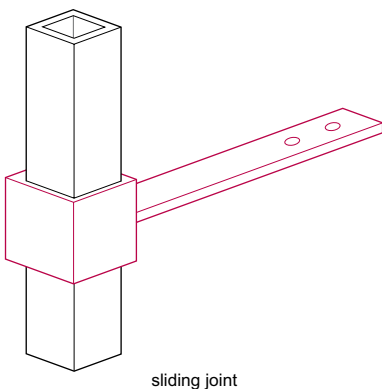

Figure 34: Juliette balcony support fixed to masonry cladding

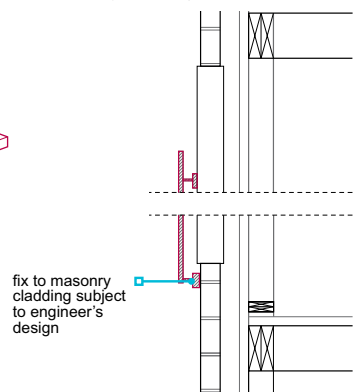
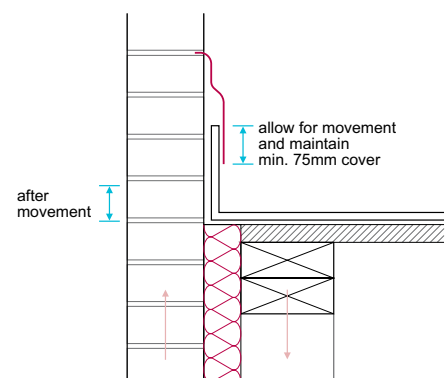

Figure 35: Flat roof to masonry abutment movement detail



6.2.9 Fire resistance

Timber walls and panels shall control and resist the spread of fire and smoke. Issues to be taken into account include:

- 1) cavity barriers and fire-stopping
- 2) services
- 3) fire resistance of the wall or panel.

All building elements should have adequate fire resistance. Materials in accordance with Building Regulations are acceptable; other materials should be assessed in accordance with Technical Requirement R3.

For guidance on the prevention of fire during construction, refer to Fire Prevention on Construction Sites, published by Fire Protection Association (www.thefpa.co.uk), and guidance from the Structural Timber Association (www.structuraltimber.co.uk) under the Site Safety Strategy, including the 16 Steps to Fire Safety and the Design Guide to Separating Distances.

6.2.9.1 Cavity barriers and fire-stopping

The installation, position and materials for cavity barriers and fire-stopping should be in accordance with the relevant Building Regulations and the design.

Where cavity barriers do not align with structural framing members, additional studs and full-depth noggings may be required to provide a solid backing for the cavity barrier; alternative designs should be supported with appropriate evidence.

Horizontal and vertical cavity barriers should be protected by DPCs arranged to shed moisture away from the sheathing. Horizontal cavity barriers in masonry cladding, except under eaves, should be protected with:

- a DPC tray with a 100mm minimum upstand, or
- a polyethylene-encased cavity barrier with a 100mm minimum upstand.

Horizontal cavity barriers in lightweight cladding should be protected by cavity trays, DPCs or flashings as appropriate.

Figure 36: Fire-stopping and compartmentation at compartment wall/roof junction

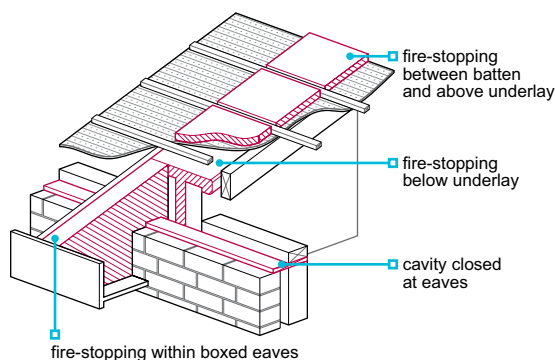

Figure 37: Horizontal cavity barrier protected with DPC

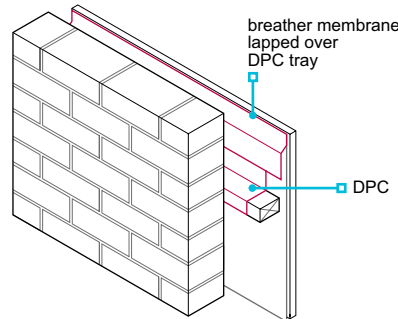
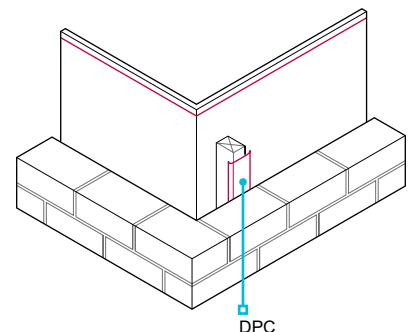

Figure 38: Vertical cavity barrier protected with DPC



6.2.9.2 Services

Only the services shown in the design should be installed in separating walls, and:

- service outlets should not impair the fire resistance of floors and walls
- service mains should not pass through separating wall cavities.

Notching or drilling of structural timber members should be carried out as detailed in the design. If these details are not available, the designer should be consulted before such operations are begun.

In Scotland, services are not permitted within a timber framed separating wall.

6.2.9.3 Fire resistance of the wall or panel

Timber frame walls should have adequate fire resistance in accordance with the relevant Building Regulations.

Timber frame systems should be supported with representative evidence to appropriate standards. Supporting evidence should be relevant to the materials, systems and details proposed.

6.2.10 Protection from moisture

Also see: Chapter 6.1 and 6.9

Timber structures and panels shall be adequately protected from the effects of moisture. Issues to be taken into account include:

- 1) cavity construction
- 2) drainage and ventilation
- 3) DPCs and cavity trays.

6.2.10.1 Cavity construction

A drained and vented cavity should be provided to reduce the risk of rain penetrating the frame. Cavity widths, measured between the cladding and sheathing, should be in accordance with Table 2.

Table 2: Cavity widths

Cladding	Minimum cavity width
Masonry	50mm nominal
Render on backed lathing	25mm nominal
Vertical tile hanging ⁽¹⁾ where a breather membrane is provided and fixed to the sheathing	Dependent on batten support layout and spacing ⁽¹⁾
Other cladding ⁽¹⁾	15mm

Note

1. See Chapter 6.9 Curtain walling and cladding.

In areas of very severe exposure to wind-driven rain, wall construction should include a 50mm cavity between the sheathing and the cladding and:

- a high performance breather membrane (see Clause 6.2.13), or
- masonry cladding which is rendered or clad with an impervious material.

Cavities should be:

- vented to allow some limited, but not necessarily through, movement of air
- kept clean, free of obstructions and capable of draining freely.

Masonry cladding should be constructed in accordance with Chapter 6.1 External masonry walls. Lightweight render cladding should be constructed in accordance with Chapter 6.11 Render. Vertical tile hanging and slating should be constructed in accordance with Chapter 6.9 Curtain walling and cladding. Proprietary cladding should be fixed in accordance with the manufacturer's recommendations and Chapter 6.9 Curtain walling and cladding.

External wall cavities should not contain electricity cables other than meter tails.

6.2.10.2 Drainage and ventilation

Drainage and ventilation should be provided to the cavity between the timber frame wall and external cladding.

Cavities between masonry cladding (including brickwork, rendered blockwork and stone) and timber frame walls should be vented. Cavity vents should be:

- equivalent to open brick perpend joints every 1.2m
- located to prevent the ingress of rain
- located to drain moisture from the cavity.

Proprietary perpend ventilators should be used. Perpend ventilators should be installed to the base of external wall cavities below the lowest timber sole plate and above finished ground level; if continuous cavity trays are installed at sole plate level, perpend ventilators should be installed above and below the tray to provide drainage and ventilation to all areas of the timber frame. Where wall areas are divided by horizontal cavity barriers and/or cavity trays, each individual cavity should be vented. Weepholes should be provided at cavity trays over openings.

Cavities between lightweight external cladding and timber frame walls should be vented or ventilated depending on cladding type. Cavity vents should be:

- installed to promote through ventilation where required
- protected to prevent the ingress of rain, insects, birds and vermin
- located to drain moisture from the cavity.

Drainage and ventilation openings should be provided to the base of external lightweight cladding at/near ground level, above horizontal cavity barriers and flashings, and above openings (such as windows and doors).

Horizontal battens used to support lightweight external cladding should be spaced off the frame using vertical counter battens to provide a path for drainage and ventilation. Battens or carrier rail systems supporting lightweight cladding should be located over and fixed to studs. Vertical battens and carrier rail systems should have joints at floor zones to accommodate differential movement.

6.2.10.3 DPCs and cavity trays

DPCs should be:

- fitted at openings to prevent rain penetration
- installed below the sole plates of ground floor walls and internal partitions
- lapped with the DPM and AVCL to enhance airtightness at sole plate level

Cavity trays should:

- be installed over openings, at abutments, and where specified at sole plate level
- have weepholes to deflect moisture out of the cavity over openings, or perpend ventilators where cavity trays are continuous

- installed over horizontal timber cavity barriers (except under eaves and verge) and lapped behind the breather membrane by at least 100mm.

- be lapped behind the breather membrane by at least 100mm to deflect moisture away from the sheathing
- be marked to BS EN 14909 and have satisfactory assessment by an appropriate independent technical approvals authority accepted by NHBC.

Clause 6.1.17 contains further guidance on the installation of cavity trays in masonry cladding.

In Northern Ireland, Scotland and the Isle of Man, and in areas of severe or very severe exposure to driving rain, masonry should form a checked rebate at the reveals of openings to avoid a straight through joint where the frame abuts the masonry.

Figure 39: Window head detail with cavity tray and weepholes

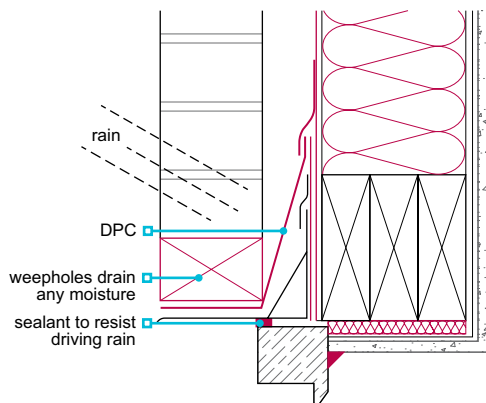
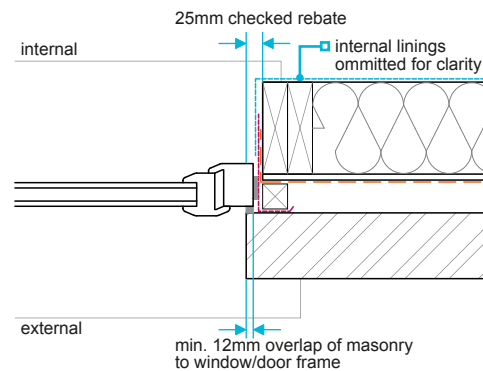

Figure 40: Checked rebate at window reveal in areas of severe or very severe exposure



Cavities should:

- extend below DPC to allow drainage
- be kept clear and be vented

- be suitably drained to prevent water build-up.

The lowest timber should be a minimum of 150mm above finished ground level. This may be reduced to 75mm in situations where the site is not subject to a high water table or where the cavity will not have standing water.

Figure 41: Lowest timber at least 150mm above external ground level

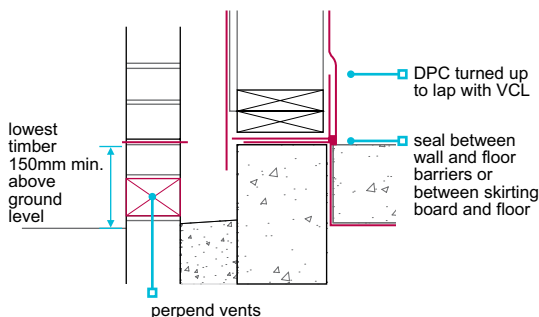
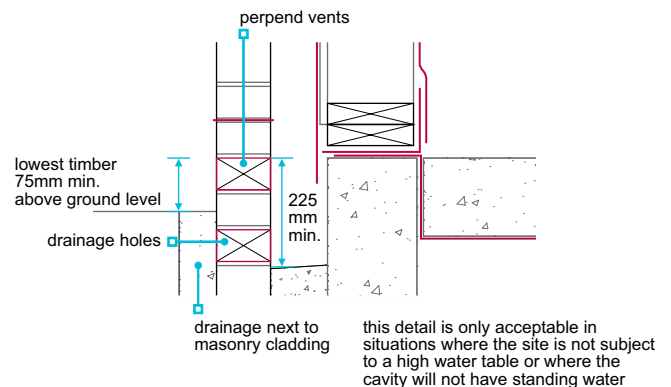

Figure 42: Lowest timber at least 75mm above external ground level



6.2.11 Timber preservation

Timber and timber products shall either have adequate natural durability or be treated with preservative to provide resistance against fungal decay and insect attack.

The following should have adequate natural durability or be preservative treated in accordance with Chapter 3.3 Timber preservation (natural solid timber):

- timber framing members including studs, rails, sole plates, etc
- external timber cladding
- engineered timber I-section or metal-web studs.

6.2.12 Air and vapour control layers

Air and vapour control layers shall be installed correctly and restrict the passage of air and water vapour from within the home into the timber frame.

A high-resistance air and vapour control layer should be provided, unless a condensation risk analysis shows that it is not necessary and the air and vapour control function is being provided by another solution compliant with NHBC Technical Requirements. An analysis in accordance with BS EN ISO 13788 (Glaser method), using the following boundary conditions, will generally be acceptable:

- >60% internal relative humidity
- 21°C internal air temperature
- -2°C external air temperature.

Air and vapour control layers should be:

- installed once framing timbers have a moisture content of less than 20%
- installed once the building is weathertight
- a minimum 500 gauge (125 micron) polyethylene sheet, vapour control plasterboard or a product assessed in accordance with Technical Requirement R3
- adequately fixed to the warm side of the insulation and frame
- fixed at 250mm centres to the top and bottom of the frame and at laps and around openings (vapour control plasterboard should be fixed in accordance with Clause 9.2.4)
- placed to completely cover the external framed wall area, including rails, studs, lintels and sills
- lapped with the DPC/DPM and at junctions to improve airtightness
- lapped into reveals and sealed to window and door frames
- sealed around service penetrations
- made good where damage has occurred.

Joints in the air and vapour control layer:

- should have 100mm minimum laps
- should be located on studs, rails or noggings, and be mechanically fixed
- may be sealed with adhesive tape for enhanced airtightness (but joints should still occur over studs, rails or noggings, and be mechanically fixed).

Where vapour control plasterboard is used, joints should be:

- positioned on studs, rails or noggings
- filled, taped and finished
- cut with care to avoid displacing the vapour control material.

Where floor zone airtightness membranes are specified for enhanced airtightness, they should be of a breathable material with a vapour resistance less than 0.6MNs/g (0.12 Sd) when tested in accordance with BS EN ISO 12572 using the set of conditions C and using five test specimens.

6.2.13 Breather membranes

Breather membranes shall be correctly installed to protect the sheathing and frame from moisture, and allow water vapour from within the frame to pass into the cavity.

Breather membranes should be:

- vapour resistant to less than 0.6MNs/g (0.12 Sd) when tested in accordance with BS EN ISO 12572 using the set of conditions C and using five test specimens
- at least Class W2 to BS EN 13859-2 with no water leakage during testing. In areas of very severe exposure (see Clause 6.1.6 for classification of exposure zones) or where liquid water penetration of the cladding is anticipated, for example open-jointed cladding, Class W1 should be used. When open-jointed claddings are used, or the membrane is likely to be left exposed during construction for a duration longer than normally to be expected (also see the membrane manufacturers' recommendations on exposure times), performance should be based on artificial aged behaviour in accordance with BS EN 13859-2. Where a vented and ventilated cavity with full rainscreen and no gaps, for example masonry or rendered board claddings is used, performance should be based on artificial aged behaviour in accordance with BS EN 13111
- capable of resisting water penetration
- durable and adequately strong when wet to resist site damage
- self extinguishing
- fixed so that vertical joints are staggered where possible, and at regular intervals, to prevent damage by wind
- lapped so that each joint is protected and moisture drains outwards and downwards
- lapped so that upper layers are over lower layers to ensure rain runs away from the sheathing
- lapped so that water is shed away from the lowest timber
- lapped with a minimum 100mm overlap on horizontal joints and 150mm on vertical joints
- fixed at a maximum spacing of 600mm horizontally and 300mm vertically
- fixed at a maximum spacing of 150mm around openings
- marked with stud positions for wall tie or cladding fixing
- applied using fixings that are in accordance with this chapter
- repaired or replaced before proceeding with the cladding, if damaged.

Figure 43: Breather membrane laps

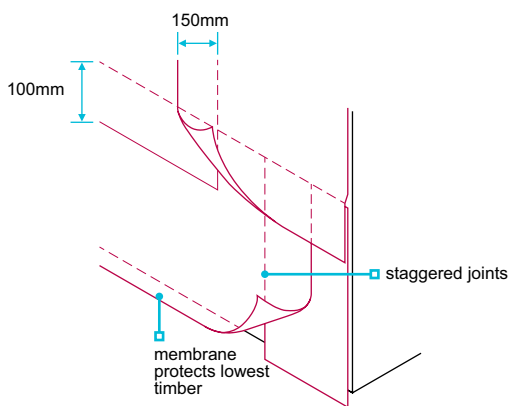
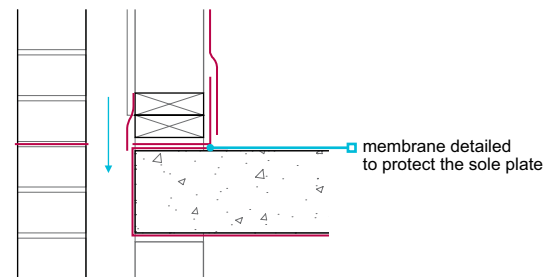

Figure 44: Breather membrane lapped over sole plate



6.2.14 Wall ties and fixings

Wall ties and fixings shall adequately connect the cladding to the timber frame.

Wall ties and their fixings should be:

- compliant with BS 845-1
- in accordance with the design
- capable of accommodating the anticipated differential movement
- of the type specified in the design
- of austenitic stainless steel
- fixed to the studs and not the sheathing using the fixings supplied by the wall tie manufacturer
- kept clean and free from mortar droppings
- spaced at a maximum of 600mm horizontally and 450mm vertically
- spaced at jambs of openings and at movement joints at a maximum of 300mm vertically and within 225mm of the masonry reveal or movement joint (additional studs may be needed)
- spaced within 225mm of the top of the wall, including at gables
- inclined away from the sheathing so that the slope is maintained following differential movement.

6.2.15 Insulation

Also see: BRE Report 262

Insulation shall be correctly installed and provide suitable performance.

Insulation should be:

- breathable, eg mineral wool (rock or glass), or
- assessed in accordance with Technical Requirement R3 for use in timber frame wall panels.

Insulation should generally be placed within the stud void and cover the whole wall area between studs. No gaps should be left:

- at corners
- at junctions with partitions
- against studs, rails or noggings
- behind services and patress panels.

Figure 45: Insulation between external wall studs

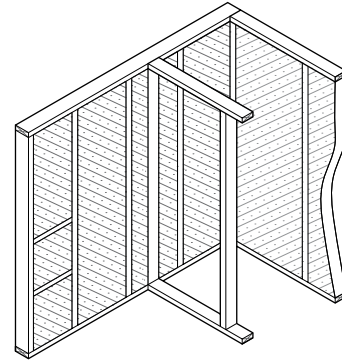

Water and heating services within walls should be on the warm side of the insulation.

Where insulation is to be installed to the external/cavity face of the frame:

- it should be assessed in accordance with Technical Requirement R3 as an integral part of the wall system
- a clear cavity should be provided, based on the dimensions set out in Table 2 in Clause 6.2.10, between the outer face of the insulation and the external cladding
- a breather membrane should be installed to protect the timber frame wall and sheathing (a secondary breather membrane to protect the external insulation may be necessary depending on the insulation manufacturer's installation instructions and independent technical approval)
- stud locator marks should be transferred onto the outer face of the insulation/external breather membrane (dependent on wall tie type and order of works)
- wall ties should transfer loads directly to the timber frame studs and not via the insulation
- the installation of lightweight cladding systems should be designed by a structural engineer to ensure adequate load transfer to the structural frame
- cavity barriers should be installed to fully close the cavity, ensuring their performance is unlikely to be made ineffective by failure of the insulation.

Where insulation, either in the form of insulated plasterboard or a separate continuous layer, is to be installed to the inside face of the frame, the fire resistance of the wall should be in accordance with Clause 6.2.9 with appropriate supporting evidence.

6.2.16 Further information

- *Structural Timber Association — Structural timber buildings fire safety in use guidance, Volume 1 — Pattern book systems, Version 3.0 April 2024*
- *Structural Timber Association — Structural timber buildings fire safety in use guidance, Volume 2 - Cavity barriers and fire stopping, Version 3.0 April 2024*
- *Structural Timber Association — Advice Note 4 Construction tolerances part 3, timber frame wall panels, Version 2 January 2014*
- *Institution of Gas Engineers & Managers — IGE/UP/7 Edition 2 + A:2008 — Gas installations in timber framed and light steel framed buildings*
- *Structural Timber Association — STA guide to differential movement — Design guidance for platform timber frame, Version 1.0 May 2008*
- *BRE Report BR 262 Thermal Insulation: avoiding risks. 3rd Edition 2002*



Chapter 6.3



Internal walls

This chapter gives guidance on meeting the Technical Requirements for internal walls, including:

- separating and compartment walls
- internal partition walls.

6.3.1	Compliance	02
6.3.2	Provision of information	02
6.3.3	Supporting load-bearing internal walls	02
6.3.4	Masonry walls	02
6.3.5	Load-bearing timber walls	05
6.3.6	Fire resistance	06
6.3.7	Sound insulation	07
6.3.8	Partitions: internal non load-bearing	09
6.3.9	Construction of timber partitions	09
6.3.10	Construction of steel framed partitions	10
6.3.11	Construction of proprietary systems	11
6.3.12	Plasterboard	11
6.3.13	Damp proof courses	11
6.3.14	Components	12
6.3.15	Further information	12

Figure reference table

Figure Reference Table 6.3

Fig No	Title/Description	Clause	Page
Figure 1	Square and plumb walls	6.3.4.3	3
Figure 2	Bonded connection	6.3.4.4	4
Figure 3	Tied connection	6.3.4.4	4
Figure 4	Incorrect use of materials	6.3.4.4	4
Figure 5	Restraint straps to concrete floors	6.3.4.5	4
Figure 6	Lintel positioning	6.3.4.7	4
Figure 7	Load-bearing timber wall	6.3.5.1	5
Figure 8	Ground floor — sole plate position	6.3.5.1	5
Figure 9	Junction of compartment wall and roof	6.3.6.2	6
Figure 10	Separating wall junction	6.3.7.1	7
Figure 11	Vertical and horizontal chases	6.3.7.1	7
Figure 12	Acoustic partition	6.3.7.2	8
Figure 13	Sound insulation to soil and vent pipe	6.3.7.2	8
Figure 14	Setting out square and plumb	6.3.9.1	9
Figure 15	Partition abutment	6.3.9.3	10
Figure 16	Wall head fixing to joist	6.3.9.3	10
Figure 17	Wall head fixing to nogging	6.3.9.3	10
Figure 18	Partition fixing to joist	6.3.9.3	10
Figure 19	Partition fixing to nogging	6.3.9.3	10
Figure 20	Additional nogging support	6.3.9.3	10
Figure 21	Deflection head	6.3.10	11
Figure 22	Partitioning abutment	6.3.10	11
Figure 23	DPC provision — masonry partition	6.3.13	11
Figure 24	DPC provision — framed partition	6.3.13	11

6.3.1 Compliance

Also see: Chapter 2.1

Internal walls shall comply with the Technical Requirements.

Internal walls, including separating, compartment and partition walls, which comply with the guidance in this chapter will generally be acceptable.

6.3.2 Provision of information

Designs and specifications shall be produced in a clearly understandable format, include all relevant information and be distributed to all appropriate personnel.

Design and specification information should be issued to site supervisors, relevant specialist subcontractors and suppliers, and include the following information:

- wall layout, with all dimensions shown
- position and size of openings and lintels
- details of junctions, indicating fire-stopping where applicable
- details of wall constructions and materials, ties and restraints
- details of junctions between a separating or compartment wall and a pitched or flat roof
- details of pipes and cables where they penetrate walls, including fire-resisting walls
- manufacturers' recommendations for assembly and fixing of propriety components.

6.3.3 Supporting load-bearing internal walls

Load-bearing internal walls shall be adequately supported by foundations.

Load-bearing internal walls should have:

- a foundation, or
- a means of support that transfers loads safely to a foundation.

Foundations should be in accordance with Part 4 of these Standards, including, where applicable, Chapter 4.3 Strip and trench fill foundations and Chapter 4.4 Raft, pile, pier and beam foundations.

6.3.4 Masonry walls

Also see: Chapters 6.1, 6.4, 6.8 and 9.2

Internal masonry walls shall be designed to support and transfer loads to foundations safely and without undue movement. Issues to be taken into account include:

- 1) structural elements
- 2) mortar mix and jointing
- 3) workmanship
- 4) bonding and tying
- 5) lateral restraint
- 6) masonry separating walls
- 7) lintels and beams.

6.3.4.1 Structural elements

Structural design of masonry walls should be in accordance with BS EN 1996-1-1.

Bricks and blocks should be selected in accordance with their intended use and as recommended in Table 1.

Table 1: Bricks and blocks in buildings up to three storeys high

Height of wall ⁽¹⁾	Unit	Minimum compressive strength ⁽²⁾
One or two storey	Blocks	2.9 N/mm ²
	Bricks	9.0 N/mm ²
Lowest storey of a three-storey wall, or where individual storeys exceed 2.7m	Blocks	7.3 N/mm ²
	Bricks	13.0 N/mm ²
Upper storeys of a three-storey wall	Blocks	2.9 N/mm ²
	Bricks	9.0 N/mm ²

Notes

1. The compressive strengths shown are applicable where the floor to ceiling distance is not greater than 2.7m.
2. The compressive strengths shown are applicable where the roof is of timber construction.

Where buildings are more than three storeys high, masonry should be designed in accordance with Technical Requirement R5, and the block strength specified in the design.

Precast concrete blocks

Concrete blocks should comply with BS EN 771. The maximum load-bearing capacity of the wall should not exceed the recommendations of the manufacturer.

Flue blocks should be in accordance with Chapter 6.8 Fireplaces, chimneys and flues.

Bricks

Bricks should comply with the relevant British Standards:

Clay bricks	BS EN 771-1
Calcium silicate bricks	BS EN 771-2
Concrete bricks	BS EN 771-3

When used in a separating wall, masonry should:

- be used in accordance with the design
- meet the structural, fire and acoustic requirements of the Building Regulations.

6.3.4.2 Mortar mix and jointing

Mortar should:

- be the correct mix and used within two hours, unless it is retarded mortar
- not be re-tempered if it has started to set
- include sulfate-resisting cement where required.

Admixtures, retarded mortars and premixed mortars should be:

- compatible with masonry and other components
- used in accordance with Clause 6.1.14 and the manufacturer's recommendations.

Air-entraining agents:

- can help reduce frost damage but cannot be used as anti-freeze
- should be used in accordance with Clause 6.1.14 and the manufacturer's recommendations.
- should be carefully measured for each batch

Bricks and blocks should be laid on a full bed of mortar, with perpend joints solidly filled.

Where walls are to be finished with wet plaster, joints should be raked out to a shallow depth to provide a key, unless the units have suitable texture or metal lathing is used, to ensure adequate bond strength is achieved. For dry lining, mortar joints should be struck off flush. For further guidance, see Clause 9.2.3.

6.3.4.3 Workmanship

Internal masonry walls and associated works should be:

- constructed in lifts/stages to prevent the distortion of wall panels during construction
- accurately set out
- reasonably plane and true
- plumb, with courses level.

Figure 1: Square and plumb walls

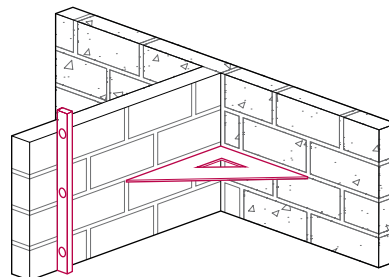
**6.3.4.4 Bonding and tying**

Internal masonry walls should:

- maintain a regular bonding pattern
- not include bricks or blocks of different types in the same wall, to avoid cracking
- be fully bonded or tied, either with a tooth at alternate courses, or an expanded metal strip or wall tie at a maximum vertical spacing of 300mm.

Joist filling should be brick or blockwork, without excessive mortar joints.

Figure 2: Bonded connection

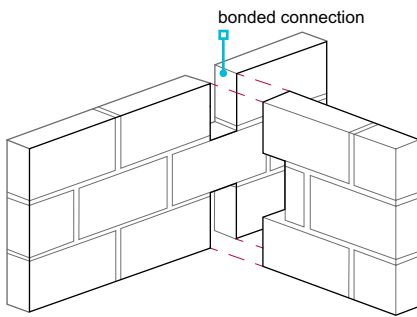

Figure 3: Tied connection

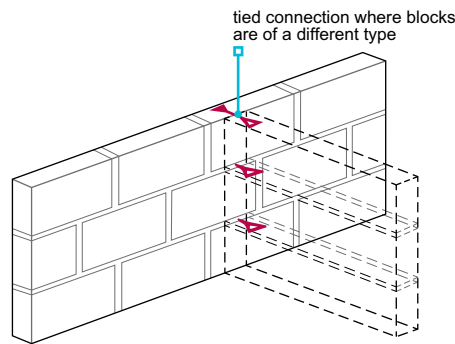
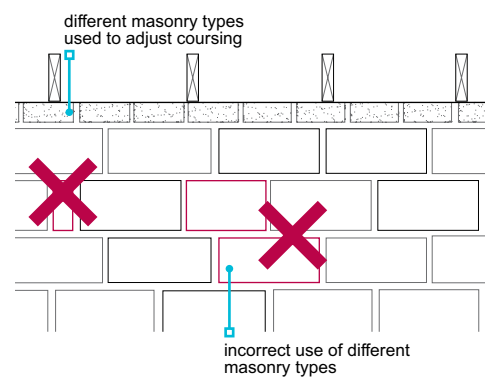

Figure 4: Incorrect use of materials



6.3.4.5 Lateral restraint

Load-bearing masonry walls, including separating walls, should be provided with lateral restraint at:

- each floor level
- ceiling level below a roof.

Restraint straps should be provided to separating walls on each level, at a maximum of 2m centres, when the floor:

- is not on, or near, the same level
- does not provide adequate restraint.

Lateral restraint should be provided in accordance with Chapter 6.4 Timber and concrete upper floors.

Timber floors

Adequate restraint can be provided by timber floors where joists have a minimum 90mm bearing. Alternatively, restraint should be provided by:

- restraint straps with a minimum 30mm x 5mm cross-section, or
- restraint type joist hangers to BS EN 845-1 with a performance equivalent to restraint straps, or
- proprietary straps in accordance with Chapter 6.4 Timber and concrete upper floors.

Concrete floors

Adequate restraint can be provided by concrete floors that have a minimum 90mm bearing on to the wall. Alternatively, restraint should be provided by:

- restraint straps that are a minimum of 450mm long, with the end turned down between a joint in the concrete floor or suitably fixed with screws.

Figure 5: Restraint straps to concrete floors

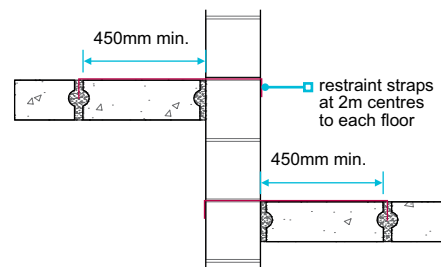

6.3.4.6 Masonry separating walls

Both leaves of a masonry cavity separating wall should be tied together to provide structural stability. The type of tie and spacing should limit the sound transmission across the cavity in accordance with Building Regulations.

6.3.4.7 Lintels and beams

Lintels and beams should be specified according to loads and spans:

- in accordance with manufacturers' recommendations, and
- designed by an engineer in accordance with Technical Requirement R5.

For masonry construction:

- concrete and steel lintels are suitable
- timber lintels should not be used
- lintels should extend beyond the end of each opening in accordance with Table 2.

Figure 6: Lintel positioning

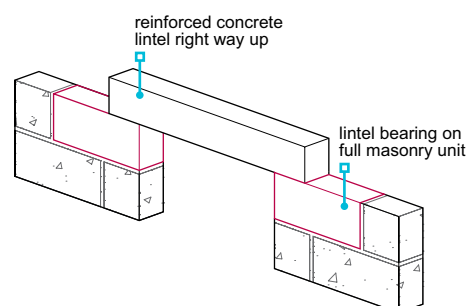

Table 2: Lintel bearings

Span (m)	Minimum length of bearing (mm)
Up to 1.2	100 ⁽¹⁾
Over 1.2	150

Note

1. Minimum bearing lengths should be in accordance with manufacturers' recommendations.

Lintels and beams should:

- have padstones where required
- be the correct way up
- bear on a full masonry unit, and be level and bedded on a solid bed of suitable mortar
- not have soft or non-durable packing
- have appropriate fire resistance in accordance with Building Regulations.

6.3.5 Load-bearing timber walls

Also see: Chapters 2.1, 6.2 and 9.2

Internal load-bearing timber walls shall be designed to support and transfer loads to foundations safely and without undue movement. Issues to be taken into account include:

- 1) structural elements
- 2) timber separating walls
- 3) timber quality.

6.3.5.1 Structural elements

Structural design of load-bearing timber walls should be in accordance with BS EN 1995-1-1.

When constructing structural elements:

- the underside of the lowest sole plate should be positioned at or above internal finished floor level (see Figure 8)
- individual studs, rails and head binders should be 38mm x 75mm minimum, although larger sizes may be required to achieve an adequate level of fire resistance
- studs should be spaced at a maximum of 600mm centres
- mid height noggings should be installed when required for additional stiffness
- lintels and cripple studs should be provided to each opening, except when the stud spacing is unaffected
- multiple studs should be included to support multiple joists, beams, girder trusses and other point loads, unless otherwise specified by the designer
- where a head binder is not provided, joists, roof trusses and other similar loads should bear directly over studs
- framing joints should be secured with a minimum of two nails per joint
- where internal walls are made up from panels, structural continuity should be maintained, eg by the use of a continuous head binder.

Figure 7: Load-bearing timber wall

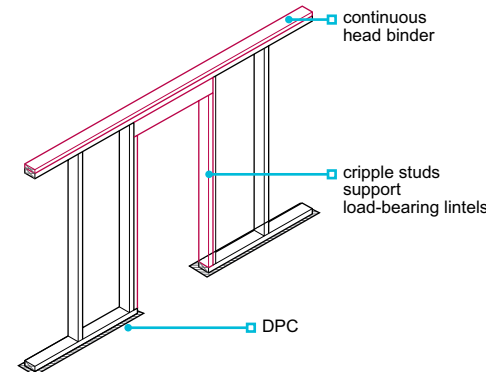
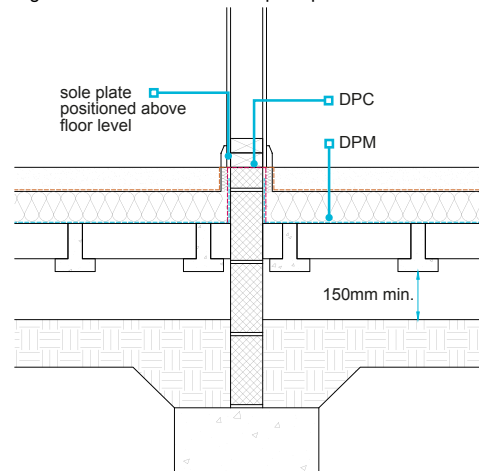

Figure 8: Ground floor — sole plate position

**6.3.5.2 Twin leaf timber separating walls**

The type and spacing of wall straps should limit sound transmission across the cavity in accordance with Building Regulations.

Wall straps should:

- be specified in accordance with the system designer's recommendations
- have a maximum cross-section of 40mm x 3mm
- be fixed below ceiling level
- be spaced a minimum of 1.2m horizontally.

6.3.5.3 Timber quality

Timber should be of the appropriate grade, moisture content and size to support the imposed loads.

Structural timber components should be of a suitable strength class, as specified by the designer to BS EN 338. Solid structural timber should be:

- machine graded to BS EN 14081, or visually graded to BS 4978 for softwoods or BS 5756 for hardwoods
- assigned a strength class based on BS EN 1912 when visually graded
- dry graded
- marked in accordance with BS EN 14081.

Further guidance on strength classes for certain timber species can be found in PD 6693.

Engineered wood products such as I-section or metal-web studs should be assessed in accordance with Technical Requirement R3.

Timber should have a maximum moisture content of 20% at the time of dry lining to minimise shrinkage.

6.3.6 Fire resistance

Also see: Chapters 6.2, Part 8.0 and 9.2

Internal walls shall have adequate resistance to the spread of fire. Issues to be taken into account include:

- | | |
|-------------------------|---------------|
| 1) fire resistance | 3) services |
| 2) typical construction | 4) materials. |

The guidance in this clause does not apply to Scotland, and reference should be made to the Scottish Building Standards Technical Handbooks.

6.3.6.1 Fire resistance

Internal walls should provide fire resistance in accordance with Building Regulations.

6.3.6.2 Typical construction

Internal walls of hollow or cavity construction (fire-resisting or otherwise) should have cavity barriers installed at:

- the perimeter
- junctions with fire-resisting floors and walls.

Fire-resisting walls should be fire-stopped or constructed to resist fire spread at:

- their perimeter
- junctions with other fire-resisting walls, floors and roofs
- openings for doors and pipes, etc.

Where fire-resisting walls are of:

- masonry construction with a cavity, they should be closed at the top
- framed construction, they should have cavity barriers at junctions with floors and ceilings.

At junctions between a separating or compartment wall and a pitched roof or flat roof:

- adequate precautions should be provided to prevent fire spread
- the separating wall should stop approximately 25mm below the top of adjacent roof trusses
- soft fire-stopping material should be installed above and below the roofing underlay to allow for movement in roof timbers to prevent 'hogging' of the tiles.

Fire-stopping should be provided within the boxed eaves and be:

- carefully cut to shape to seal the boxed eaves fully
- fixed in accordance with manufacturers' recommendations.

The wall dividing an integral, or attached, garage and any floor above should be designed to act together to provide adequate resistance to fire spread, in accordance with the Building Regulations. Where the garage has either no ceiling or there is no floor in the space above, vertical fire separation may be required.

For timber constructions, fire-stopping material should be compressible to accommodate timber shrinkage without affecting fire-stopping.

Figure 9: Junction of compartment wall and roof

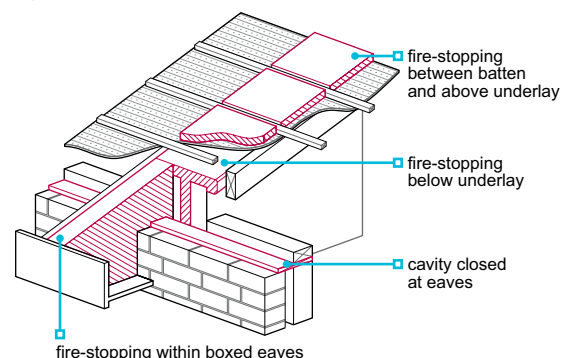

6.3.6.3 Services

Where services such as pipes, cables and ducting pass through fire-resisting walls, penetrations should be fire-stopped.

Fire-stopping should be:

- in accordance with Building Regulations and the design information
- completed neatly.

6.3.6.4 Materials

The selected fire-stopping material should be appropriate for the application. Suitable fire-stopping materials include:

- rock fibre quilt
- cement mortar
- gypsum plaster
- intumescent mastic or preformed strip
- proprietary sealing systems assessed in accordance with Technical Requirement R3.

6.3.7 Sound insulation

Also see: BS 8000-8

Walls shall be insulated with materials of suitable thickness and density to provide adequate resistance to the transmission of sound. Issues to be taken into account include:

- 1) sound-resisting construction
- 2) rooms which contain a WC.

6.3.7.1 Sound-resisting construction

Masonry separating walls

In England, Scotland, Wales and Northern Ireland, separating walls may be registered and built in accordance with Robust Details as an alternative to pre-completion sound testing.

To maintain sound insulation:

- the correct blocks should be used
- fully fill joints, mortar beds and perpend
- use only approved wall ties
- wall ties should be spaced 900mm minimum horizontally and 450mm minimum vertically
- avoid any reduction in the thickness of masonry
- ensure spaces around joists are fully filled with masonry and pointed with sealant around the joist

In masonry separating cavity walls, wall ties should be type A in accordance with Building Regulations.

Solid separating walls can be taken through the inner leaf of an external cavity wall and tied or bonded in accordance with either Building Regulations or Robust Details guidance.

Chases can reduce the sound insulation value of a wall and should:

- be cut only where specified in the design
- not be cut using impact power tools where there is a risk of damage
- not exceed 1/6 of the thickness of the single leaf where horizontal
- not exceed 1/3 of the thickness of the single leaf where vertical
- not be chased where hollow blocks are used, unless specifically permitted by the manufacturer
- be fully filled with mortar
- be staggered on each side of the wall to avoid them being back to back.

- close the junction between separating and external cavity walls with flexible cavity stops
- care should be taken when specifying dry lining, as the thickness of plasterboard layers, and the methods of sealing and fixing, can affect the transmission of sound
- holes, voids and hairline cracks should be avoided or made good, as they can significantly reduce the effectiveness of a sound-insulating wall.

Figure 10: Separating wall junction

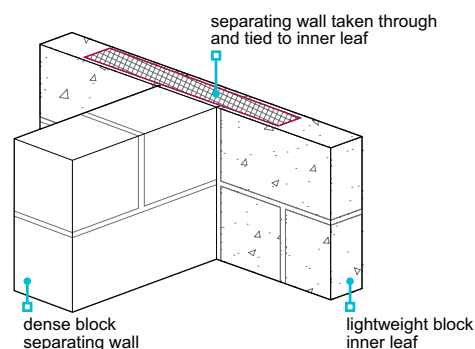
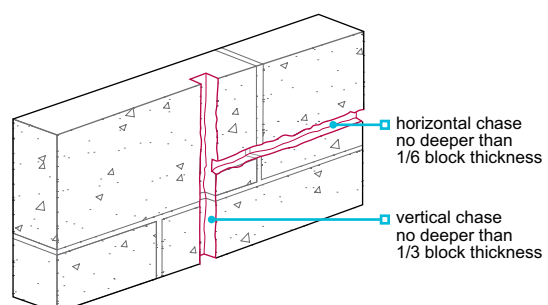

Figure 11: Vertical and horizontal chases



Separating walls of framed construction

Separating walls of framed construction should not have gaps in the:

- mineral wool quilt
- plasterboard layers
- fire-stopping.

Flanking walls

The construction of the flanking wall and the position of openings should comply with Building Regulations.

6.3.7.2 Rooms containing a WC

The construction should comply with Building Regulations, including the recommended sound reduction between rooms that include a WC and adjacent:

- living rooms
- dining rooms
- studies
- bedrooms, except where the WC is ensuite.

Studwork

To achieve the required level of sound reduction, 75mm timber studwork or 45mm steel framing should be constructed with either:

- two layers of 12.5mm plasterboard (each sheet 10kg/m² minimum) on each side, with joints staggered and filled
- one layer of 12.5mm plasterboard (each sheet 10kg/m² minimum) on each side and 25mm unfaced mineral wool (10kg/m³ minimum) between the studs, with all joints well sealed.

Figure 12: Acoustic partition

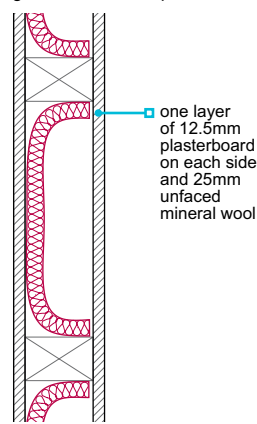

Other forms of studwork construction may be acceptable where in accordance with the guidance in supporting documents to the Building Regulations or where independent evidence of performance is available.

Blockwork partitions

Masonry partitions provide adequate sound insulation where:

- blocks have a minimum density of 600kg/m³ and are finished on both sides with 13mm of plaster or 12.5mm plasterboard, and
- blocks are tied at every course to adjoining walls, with joints fully filled.

Further guidance can be found in the relevant Building Regulations.

Proprietary partitions

Independent test evidence of the system's performance is required in accordance with Technical Requirement R3. Criteria for testing is not provided in R3.

Sound insulation of soil pipes in floor voids and boxings

All sections of soil and vent pipes, including those in bathrooms or ground floor stub stacks, should be fully soundproofed.

Where soil and vent pipes run horizontally through a floor void, above or below a habitable room, they should be:

- wrapped in at least 25mm of unfaced mineral wool (10kg/m³ minimum)
- adequately supported to avoid contact with the floor decking or ceiling.

Sound insulation should be provided to soil pipes passing through homes by:

- an encased boxing, using material (15kg/m²) and
- wrapping the pipe with a minimum 25mm of unfaced mineral wool (10kg/m³ minimum). The insulation should be continued through the thickness of each sound-insulating floor.

Figure 13: Sound insulation to soil and vent pipe

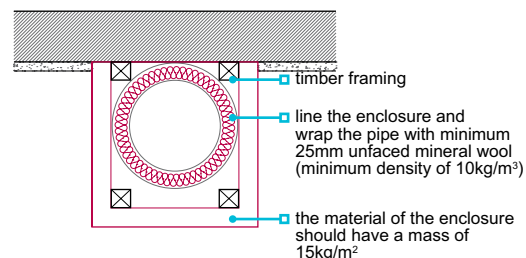

Soil and vent pipes which hold a satisfactory assessment by an appropriate independent technical approvals authority acceptable to NHBC, may be acceptable where the requirements of the Building Regulations are met.

6.3.8 Partitions: internal non load-bearing

Non load-bearing partitions shall have adequate strength and support.

The following constructions are acceptable:

- masonry partitions
- timber partitions using 63mm x 38mm studs, rails and head binders with compatible spacing and plasterboard thickness
- steel partitions using studs, and head and base rails, from a minimum section of 43mm x 32mm x 0.45mm
- proprietary partitions in accordance with Technical Requirement R3.

Walls and partitions should:

- be appropriately supported
- not be supported by a floating floor which incorporates a compressible layer, unless the material is specifically manufactured for that purpose
- be used in accordance with manufacturers' guidance.

Masonry partitions should be supported on:

- foundations
- other masonry partitions or walls
- concrete floors
- steel or concrete beams, which may require padstones.

Masonry partitions should not be supported by timber joists or beams.

Where stud partitions or proprietary plasterboard partitions are supported by a timber floor, extra noggings or joists should be specified, unless it can be shown that the deck can transfer the load without undue movement.

6.3.9 Construction of timber partitions

Also see: Chapter 9.2

Construction of timber stud internal walls shall ensure adequate stability, including:

- 1) setting out and workmanship
- 2) size of timber members
- 3) fixing.

6.3.9.1 Setting out and workmanship

Timber partitions should be:

- placed so the lowest timber is positioned at or above the internal finished floor level (see Figure 8)
- correctly positioned, square and plumb
- have studwork spaced at centres to suit the plasterboard thickness
- have extra studs at openings, as required.

Figure 14: Setting out square and plumb

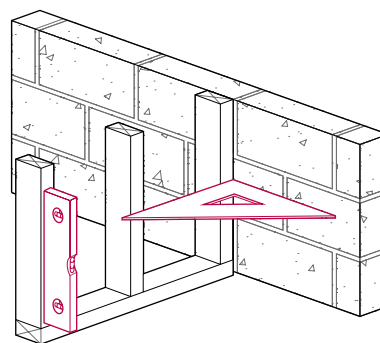

6.3.9.2 Size of timber members

Timber partitions should be constructed in accordance with the design information. Unless designed otherwise, the minimum specification for all partitions should be in accordance with Table 3.

Table 3: Timber sizes for partition walls

Component	Size
Sole plate, rails and head binders	63mm x 38mm
Studs	63mm x 38mm at maximum 600mm centres
Blocking/nogging for support of plasterboard	43mm x 38mm
Blocking/nogging for other purposes	63mm x 38mm

Framing joints should be secured with two nails per joint.

6.3.9.3 Fixing

Partitions should:

- be firmly fixed to each other and to abutting walls; noggings or extra studs should be used where necessary
- be fixed to the structure where possible
- be fixed to noggings when parallel to structural elements
- not be over wedged against floor joists or roof trusses.

Where partitions are non load-bearing, allowance should be made for floors, ceilings or roofs to deflect as necessary, so that the partition does not become load-bearing, in accordance with the design.

Figure 15: Partition abutment

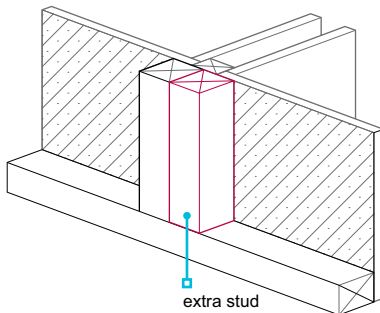

Figure 16: Wall head fixing to joist

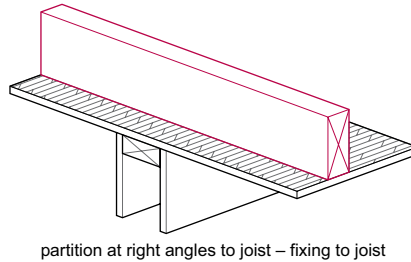

Figure 17: Wall head fixing to nogging

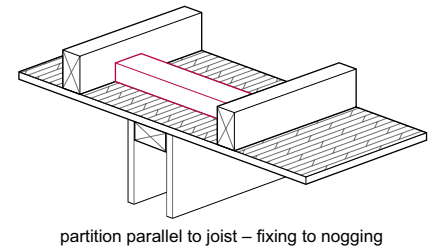

Figure 18: Partition fixing to joist

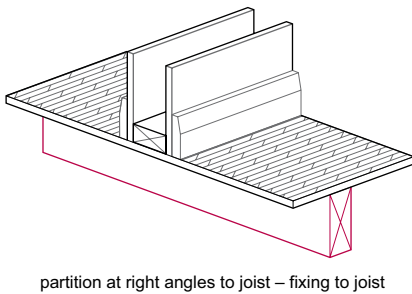

Figure 19: Partition fixing to nogging

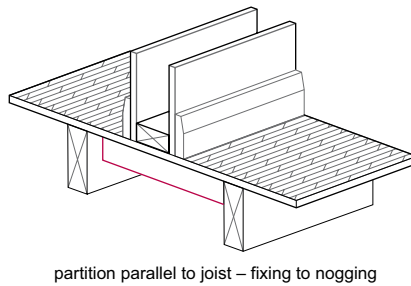
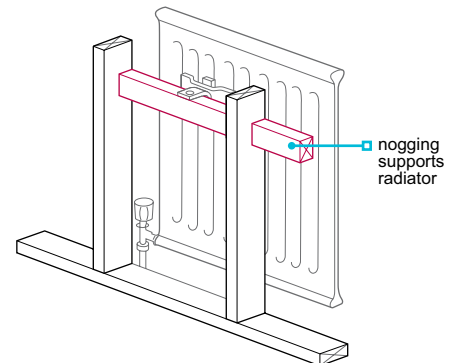

Figure 20: Additional nogging support



Noggings should be provided to support fittings, such as radiators, wall-mounted boilers, sanitary fittings and kitchen units, etc.

6.3.10 Construction of steel framed partitions

Non load-bearing steel framed walls shall be suitably constructed.

Noggings or straps should be provided as required to support fittings, such as radiators, wall-mounted boilers, sanitary fittings and kitchen units, etc. Non load-bearing partitions should not be wedged against floor joists, ceiling joists or roof trusses. Allowance should be made for floors, ceilings or roofs to deflect as necessary, so that the partition does not become load-bearing, in accordance with the design. They should be:

- constructed in accordance with manufacturers' requirements and the design
- correctly positioned, square and plumb
- supported on a structural floor, but not a floating floor that incorporates a compressible layer, unless specifically designed for that purpose
- fixed to the floor at the head, to each other and to abutting walls
- provided with extra studs at openings where required
- finished in accordance with Chapter 9.2 Wall and ceiling finishes.

Figure 21: Deflection head

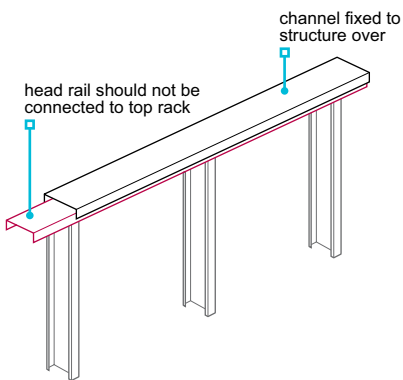
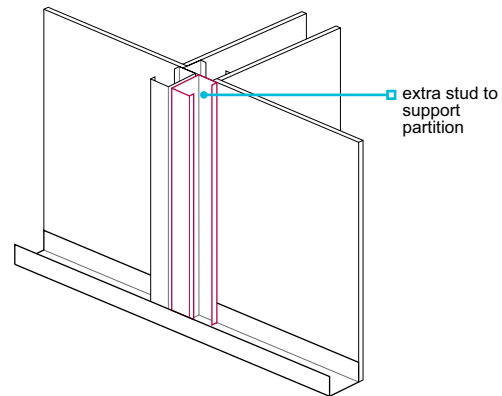

Figure 22: Partitioning abutment



6.3.11 Construction of proprietary systems

Proprietary partition systems shall be suitable for their intended purpose and erected in accordance with the manufacturer's recommendations.

Proprietary partitions should be assessed in accordance with Technical Requirement R3 and:

- constructed and specified according to the manufacturer's recommendations, including construction sequence
- correctly positioned, square and plumb.

Timber or other additional fixings should be provided for radiators, electrical outlets, switches, etc.

6.3.12 Plasterboard

Also see: Chapter 9.2

Plasterboard shall be of a suitable thickness for its intended use.

Dry lining should comply with BS 8000-8. Plasterboard should be to BS EN 520 or BS EN 15283, and be:

- 9.5mm for stud spacing up to 450mm
- 12.5mm or thicker, for stud spacing up to 600mm.

Tapered edge boards should be used where the plasterboard is to be jointed before decoration.

For fire and sound-resisting walls (eg separating walls and walls to WCs), the correct thickness, number of layers and sealing should be specified in the design information.

For guidance on the use of plasterboard in wet areas ie, bath and shower areas, please refer to Chapter 9.2 Wall and ceiling finishes.

6.3.13 Damp proof courses

Also see: Chapter 5.4

DPCs shall be installed where required to prevent moisture entering the building.

Load-bearing partition walls built on foundations should have a DPC. Where partitions which could be affected by residual damp (eg timber or steel) are placed on concrete floors, a DPC should be provided directly below, even where there is a DPM beneath the slab.

DPCs should be:

- at least the width of the wall or partition
- linked with any adjoining DPM
- continuous or lapped by a minimum of 100mm.

Figure 23: DPC provision — masonry partition

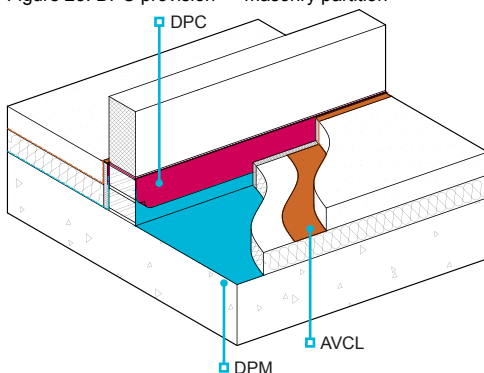
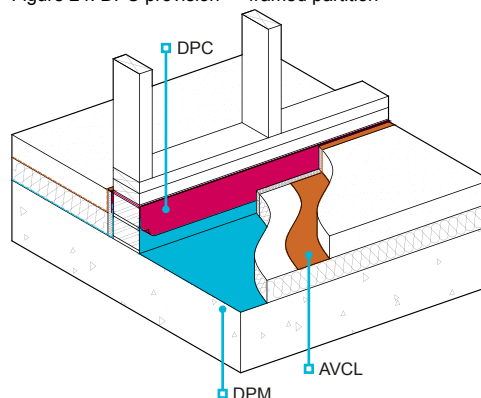

Figure 24: DPC provision — framed partition



Where steps are necessary in the ground floor slab, a DPC should be:

- incorporated as a continuous link between the upper and lower DPM
- protected from damage during construction.

Where steps are greater than 150mm, structural waterproofing should be provided in accordance with Chapter 5.4 Waterproofing of basements and other below ground structures.

Materials acceptable for DPCs include:

Bitumen based materials	BS 6398, BS EN 14967
Polyethylene	BS 6515
Thermoplastics and elastomers	BS EN 14909
Proprietary materials	Technical Requirement R3

6.3.14 Components

Wall ties and related items shall be of the appropriate type and strength and shall have adequate durability.

Joist hangers, restraint straps, bond ties, etc should be protected against corrosion. Ferrous metals with the following levels of protection are acceptable:

- post-galvanizing to BS EN ISO 1461, or
- pre-galvanizing to BS EN 10143.

6.3.15 Further information

- *BS 8000-8 Workmanship on construction sites — Design and installation of dry lining systems. Code of practice*



Chapter 6.4



Timber and concrete upper floors

This chapter gives guidance on meeting the Technical Requirements for timber and concrete upper floors.

6.4.1	Compliance	02
6.4.2	Provision of information	02
6.4.3	Upper floor design	02
6.4.4	Fire spread	03
6.4.5	Sound insulation	04
6.4.6	In-situ concrete floors and concreting	04
6.4.7	Precast concrete	04
6.4.8	Timber joist spans	05
6.4.9	Timber joist performance	07
6.4.10	Construction of timber floors	07
6.4.11	Joists supported by intermediate walls	09
6.4.12	Joists connected to steel	10
6.4.13	Joists into hangers	10
6.4.14	Timber joist and restraint straps	12
6.4.15	Strutting	14
6.4.16	Joists and openings	14
6.4.17	Multiple joists	15
6.4.18	Notching and drilling	16
6.4.19	Floor decking	17
6.4.20	Floating floors or floors between homes	19
6.4.21	Further information	19



Figure reference table

Figure Reference Table 6.4

Fig No	Title/Description	Clause	Page
Figure 1	Support of non-loadbearing partition on I-joisted floors	6.4.3.1	3
Figure 2	Support of non-loadbearing partition on metal web joisted floors	6.4.3.1	3
Figure 3	Minimum distances between timber floor and heat sources like chimneys	6.4.4	3
Figure 4	Use of infill blocks as spacers	6.4.7	4
Figure 5	Strapping of floor spanning parallel to wall	6.4.7	5
Figure 6	Timber stored on bearers clear off the ground	6.4.9	7
Figure 7	Level bearing of floor joists	6.4.10.1	8
Figure 8	Typical engineered floor joists	6.4.10.3	8
Figure 9	Typical web stiffeners on I-joists	6.4.10.3	9
Figure 10	Typical bearing stiffeners on metal web joists	6.4.10.3	9
Figure 11	Blocking to restrain top flange of metal web joists	6.4.10.3	9
Figure 12	Blocking to restrain top flange of I-joists	6.4.10.3	9
Figure 13	Solid joists supported on internal load-bearing wall	6.4.11	9
Figure 14	I-joists supported on internal load-bearing wall	6.4.11	9
Figure 15	Metal web joists supported on internal load-bearing wall	6.4.11	9
Figure 16	Notching of solid timber joist into steel beam	6.4.12	10
Figure 17	Strutting of solid joists notched into steel beam	6.4.12	10
Figure 18	I-joist supported on timber blocking fixed to web of steel beam	6.4.12	10
Figure 19	Metal web supported on top flange of steel beam	6.4.12	10
Figure 20	Types of joist hangers	6.4.13	11
Figure 21	Solid timber joist supported on hanger	6.4.13	11
Figure 22	Blocking of solid joists supported on hanger	6.4.13	11
Figure 23	I-joist supported on hanger	6.4.13	11
Figure 24	Blocking of metal web joists supported on hanger	6.4.13	11
Figure 25	Side fixing of restraint straps to floor joists	6.4.14	12
Figure 26	Top fixing of restraint straps to floor joists	6.4.14	12
Figure 27	Restraint strap required with use of non-restraint joist hangers	6.4.14	12
Figure 28	Restraint strap fixed to solid timber joists parallel to external wall	6.4.14	12
Figure 29	Restraint strap fixed to I-joists parallel to external wall — through noggings set flush with top flange	6.4.14	13
Figure 30	Restraint strap fixed to I-joists parallel to external wall — through slots cut in top of web	6.4.14	13
Figure 31	Restraint strap fixed to metal web joists parallel to external wall	6.4.14	13
Figure 32	Typical strutting arrangement	6.4.15	14
Figure 33	Strongback bracing	6.4.15	14
Figure 34	Trimming around openings in floors	6.4.16	15
Figure 35	I-joist connection of trimmer and trimming joists	6.4.16	15
Figure 36	Metal web joist connection of trimmer and trimming joists	6.4.16	15
Figure 37	Fixing of multiple solid joists	6.4.17	16
Figure 38	Fixing of double I-joists	6.4.17	16
Figure 39	Notching and drilling requirements of solid joists	6.4.18	17
Figure 40	Service conduits in metal web joists	6.4.18	17
Figure 41	Longitudinal support to square edged boards	6.4.19.1	18
Figure 42	Short edges of floorboards supported on joists	6.4.19.1	18
Figure 43	Floorboards abutting rigid upstands	6.4.19.1	18

6.4.1 Compliance

Also see: Chapter 2.1

Timber and concrete upper floors shall comply with the Technical Requirements.

Timber and concrete upper floors that comply with the guidance in this chapter will generally be acceptable.

6.4.2 Provision of information

Designs and specifications shall be produced in a clearly understandable format, include all relevant information and be distributed to appropriate personnel.

Design and specification information should be issued to site supervisors, relevant specialist subcontractors and suppliers, and include the following information:

- direction of floor span, and size and spacing of joists or concrete components
- size of trimmers and trimming joists
- position of strutting
- detailing of openings in the floor
- supporting walls below
- walls and partitions above
- positions of restraint straps
- positions of large service penetrations, eg chimneys and SVPs
- position of insulation
- details of all junctions
- manufacturers' recommendations for assembly and fixing of proprietary components
- detailing for acoustic and fire separation where floor forms a compartmentation between dwellings.

6.4.3 Upper floor design

Also see: Chapter 6.5

Upper floors shall support and transmit loads safely to the supporting structure without undue deflection or deformation. Issues to be taken into account include:

- 1) loads and support to partitions
- 2) steelwork
- 3) support of external envelope and projections.

6.4.3.1 Loads and support to partitions

Structural design of timber and concrete upper floors should be in accordance with BS EN 1991-1-1.

The design of upper floors should account for dead loads, including:

- floor structure, decking and finishes
- ceilings and applied finishes
- walls and partitions supported by the floor
- permanent fixtures such as boilers, watertanks, etc.

Imposed loads should be calculated in accordance with the relevant British Standards, including BS EN 1991-1-1 which recommends:

- 1.5kN/m² for self-contained homes
- values for communal areas serving flats or maisonettes.

Bearers or additional joists should be used to support heavy loads.

Joists built into separating walls may provide lateral support, and should be detailed to ensure that sound insulation and fire resistance requirements are met.

Masonry partitions

Where first floor masonry partitions cannot be built directly in line with ground floor masonry walls, steel or reinforced concrete support should be specified. Masonry should not be supported on timber or engineered joists.

Lightweight partitions

Where multiple solid timber joists support lightweight non load-bearing partitions which are parallel to the joists, they should be suitably fixed together. Where I-joists and metal web joists are used, they should:

- be positioned centrally below a non load-bearing partition and, where necessary, additional joists should be doubled or tripled in accordance with the designer's and manufacturer's recommendations
- support the weight of the non load-bearing partition by noggings or bearers fixed to the joists on either side. Unless designed otherwise, noggings should be a minimum 38mm x 90mm minimum at 600mm centres and fixed with metal clips. The sole plate of the non load-bearing partition should be fixed to the noggings (see Figures 1 and 2), or
- be in accordance with the manufacturer's recommendations.

Figure 1: Support of non-loadbearing partition on I-joisted floors

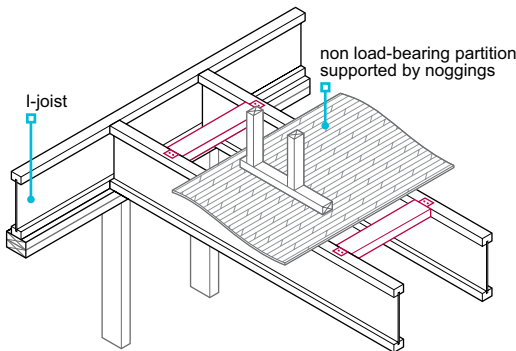
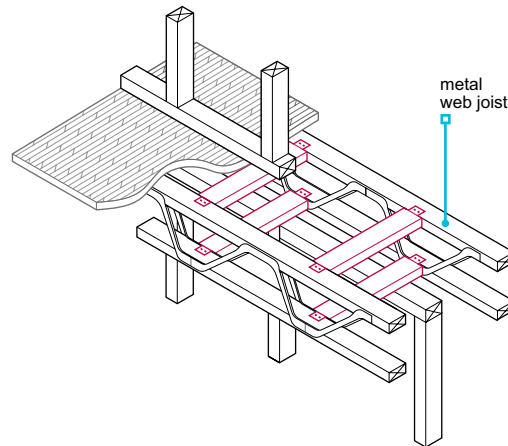

Figure 2: Support of non-loadbearing partition on metal web joisted floors



6.4.3.2 Steelwork

Steelwork supporting upper floor should be:

- designed by an engineer in accordance with Technical Requirement R5 and comply with Chapter 6.5 Steelwork
- sized to allow an adequate bearing of the floor system.

Structural continuity of the floor should be provided by the use of continuous decking fixed to joists on both sides of a transverse steel joist.

Steel beams should be protected by a suitably durable paint coating as detailed in Chapter 6.5 Steelwork.

6.4.3.3 Support of external envelope and projections

Deflection of concrete upper floors should be adequately designed, monitored and controlled to ensure it does not adversely affect its proper functioning or appearance.

Particular attention should be paid to edges of upper floors in flat slab constructions or floors without edge beams spanning over 5m.

Where upper floors are required to support balconies and/or masonry support systems, and horizontal joints are to be provided as part of the external envelope of a framed building, they should be suitably designed and detailed to cater for both thermal and moisture movements of the envelope, in addition to any residual floor deflection that may be expected from the supporting structure. The concrete floor, together with any associated horizontal (eg masonry) movement joint it supports, should be appropriately designed, taking into consideration the following:

- floor deflection behind the cladding/envelope/balcony
- building elevation and load paths
- cladding (eg masonry) support system deflections
- elastic shorting of structural columns and walls
- cladding (eg masonry) joint details
- building sway.

Further guidance on horizontal movement joints in masonry can be found in Chapter 6.1 External masonry walls.

6.4.4 Fire spread

Adequate fire resistance and fire-stopping shall be provided by floors between homes and at penetrations. Upper floors shall be constructed to ensure structural timber is located away from heat sources.

Floors and ceilings should:

- comply with the relevant Building Regulations and Technical Requirement R3
- be in accordance with the design
- have adequate fire-stopping
- be able to resist the passage of smoke when the fire-stopping has been installed.

Figure 3: Minimum distances between timber floor and heat sources like chimneys

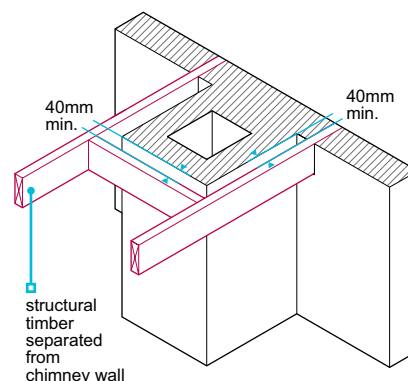

Timber

To counteract fire spread:

- combustible material should be kept away from heat sources
- structural timber should be separated from sources of heat in accordance with Chapter 6.8 Fireplaces, chimneys and flues.

Ancillary product

Where ceilings of intermediate floors in houses, or compartment floors in flats/apartments, are perforated or penetrated by services such as recessed light fittings (downlighters), ceiling-mounted air valves, vents, and extractor fans and pipes, the floor construction should still achieve the required period of fire resistance.

When installing such ancillary products and/or services, including their fire-stopping elements and intumescent seals used to maintain the fire resistance of the floor, one of the following should be met:

- a satisfactory fire test evidence and/or extended field of application reports that support the use of such products/systems in the particular type of floor being considered, or
- products and systems with a satisfactory assessment by an appropriate independent technical approvals authority accepted by NHBC covering the particular type of floor being considered, or
- a proprietary floor system with satisfactory assessment by an appropriate independent technical approvals authority accepted by NHBC which includes the use of a specific floor type and ancillary products which have been demonstrated to be satisfactory through testing and assessment, and are to be used within the limitations of the certification.

6.4.5 Sound insulation

Upper floors shall be constructed to ensure that sound transmission is adequately limited.

Timber upper floors should comply with Building Regulations and Chapter 9.3 Floor finishes.

6.4.6 In-situ concrete floors and concreting

In-situ concrete upper floors shall be adequately reinforced and of a mix which is suitable for the location and intended use, and appropriately constructed.

Concrete floors should:

- comply with BS EN 1992-1-1 and Chapter 3.1 Concrete and its reinforcement
- comply with the design
- be reasonably level and smooth, especially at doorways and junctions
- be in accordance with Technical Requirement R3 where proprietary elements are used.

6.4.7 Precast concrete

Precast concrete upper floors shall be erected in accordance with the design.

Precast concrete flooring systems should be in accordance with Technical Requirement R3, applicable product standards and BS EN 1992-1-1.

For precast concrete beam and block systems:

- details of the manufacturer's assembly instructions and any independent certification should be available on site and followed
- beams, planks or infill blocks that are damaged should not be used
- adequate support should be provided until design strength is reached
- joints should be grouted in accordance with the manufacturer's recommendations.

Figure 4: Use of infill blocks as spacers

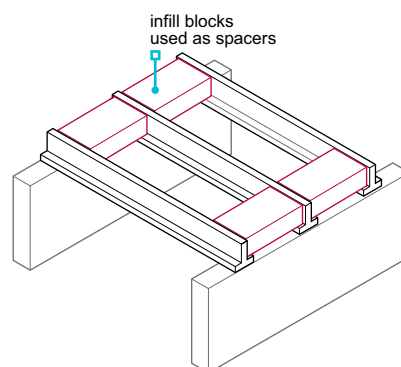

Bearings should be:

- solid and level
- 90mm minimum on masonry (open frogs in brickwork should be filled)

The setting out of beam and block floors should:

- ensure correct spacing between beams, using infill blocks as spacers (see Figure 4)
- be in accordance with the design

Infill blocks should:

- be omitted or cut where necessary to allow for services

Where floors rely on structural topping or in-situ make-up sections, propping may be needed until the in-situ concrete has reached design strength.

Trimmed openings

Where voids in precast concrete floors are to be trimmed:

- specifications and drawings should be followed
- steel trimmer shoes may be used.

Double beams, common around trimmed openings, should be adequately supported until all voids have been solidly concreted and the concrete has reached its design strength.

Restraint straps and ties

Straps:

- should be shown in the design
- are generally required where beams run parallel with the wall (see Figure 5).

- 75mm minimum on steelwork.

- allow for additional beams where required to support concentrated loads such as partitions.

- be cut carefully and neatly without damage (not using a hammer and bolster).

Figure 5: Strapping of floor spanning parallel to wall

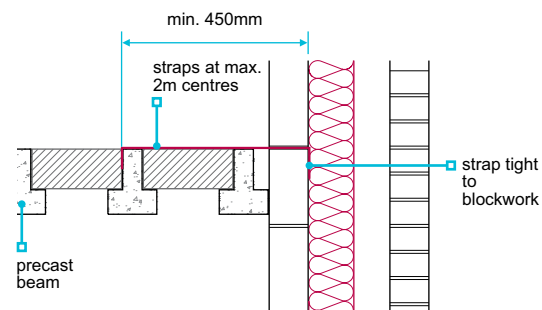

6.4.8 Timber joist spans

Timber floor joists shall be adequate for the spans and loads, and be correctly installed.

Solid timber joist sizes are provided in the BS 8103-3 span tables. Where the tables do not apply, or where there are concentrated loads, floor joists should be designed by an engineer in accordance with Technical Requirement R5.

Span tables for solid timber joists

Tables 1 and 2 in this chapter are derived from the BM TRADA Technology Ltd. Eurocode 5 span tables for solid timber members in floors, ceilings and roofs for dwellings (4th edition). Tables 1 and 2 give permissible clear spans of simply supported domestic floor joists of solid timber for specified loadings, sizes and spacings calculated in accordance with EC5. The tables make no allowance for concentrated or line loads applied by partitions, trimmers or other similar loads. The minimum bearing length assumed for the tables is 40mm unless noted otherwise, and longer bearing lengths may be required for other practical reasons. The section sizes are based on regularised ALS or CLS timber.

For timber floors between homes (compartment floors):

- to meet acoustic performance, the dead load of the construction of up to 1.25kN/m² may be assumed
- use the three right-hand columns from Tables 1 and 2.

For upper floors with 22mm thick chipboard decking and a 12.5mm plasterboard ceiling:

- a dead load of up to 0.5kN/m² may be assumed
- use the centre three columns from Tables 1 and 2.

Where lightweight non load-bearing partitions weigh up to 1.0kN (101.9kg) per metre run and are parallel to the joists, the following applies:

- partitions may be directly supported by one or two additional joists
- partitions should be fixed through the floor decking into the joist(s) beneath
- where similar lightweight partitions run at right-angles to the joists, the maximum spans in Tables 1 and 2 should be reduced by 10%
- for all other additional loads, joist sizes should be designed by an engineer in accordance with Technical Requirement R5.

Table 1: Permissible clear spans for domestic floor joists. Strength class C16

Imposed load not exceeding $q_k = 1.5 \text{ kN/m}^2$ or $Q_k = 2.0 \text{ kN}$. Service class 1 or 2.

Dead load g_k (kN/m ²) excluding self-weight of joist											
Size of joist		gk not more than 0.25			gk not more than 0.50			gk not more than 1.25			
		Joist spacing (mm)									
		400	450	600	400	450	600	400	450	600	
Breadth (mm)	Depth (mm)	Maximum clear span (m)									
38	95	1.71*	1.62	1.40	1.61	1.52	1.32	1.40	1.33	1.16	
38	120	2.37*	2.24*	1.95	2.19*	2.08*	1.82	1.87	1.78	1.56	
38	145	2.86*	2.75*	2.49	2.69*	2.59*	2.33	2.35	2.23	1.97	
38	170	3.34*	3.21*	2.91	3.15*	3.03*	2.74	2.75	2.64	2.39	
38	195	3.83*	3.68*	3.34	3.61*	3.47*	3.14	3.15	3.03	2.73	
38	220	4.31*	4.14*	3.76	4.06*	3.90*	3.54	3.55	3.41	3.08	
44	95	1.84*	1.74	1.51	1.72	1.63	1.42	1.50	1.42	1.24	
44	120	2.49*	2.39*	2.09	2.33*	2.22*	1.95	1.99	1.89	1.67	
44	145	3.00*	2.89*	2.62	2.83*	2.72*	2.46	2.47	2.37	2.10	
44	170	3.51*	3.38*	3.06	3.31*	3.18*	2.88	2.89	2.78	2.51	
44	195	4.02*	3.86*	3.51	3.79*	3.64*	3.30	3.32	3.18	2.88	
44	220	4.52*	4.35*	3.95	4.26*	4.10*	3.72	3.73	3.59	3.25	
47	95	1.90*	1.79	1.56	1.77	1.68	1.47	1.54	1.46	1.28	
47	120	2.55*	2.45*	2.16	2.40*	2.28*	2.01	2.05	1.95	1.72	
47	145	3.07*	2.95*	2.68	2.89*	2.78*	2.52	2.53	2.43	2.16	
47	170	3.59*	3.45*	3.13	3.38*	3.25*	2.95	2.96	2.84	2.57	
47	195	4.10*	3.95*	3.59	3.87*	3.72*	3.38	3.39	3.26	2.95	
47	220	4.62*	4.44*	4.04	4.36*	4.19*	3.81	3.82	3.67	3.32	
63	95	2.17*	2.06*	1.80	2.02*	1.92	1.68	1.74	1.66	1.47	
63	120	2.80*	2.70*	2.45	2.64*	2.54*	2.29	2.30	2.20	1.95	
63	145	3.38*	3.25*	2.96	3.19*	3.07*	2.79	2.79	2.68	2.43	
63	170	3.94*	3.80*	3.46	3.72*	3.58*	3.26	3.27	3.14	2.85	
63	195	4.51*	4.34*	3.95	4.26*	4.10*	3.73	3.74	3.60	3.26	
63	220	5.07*	4.88*	4.45	4.79*	4.61*	4.20	4.21	4.05	3.68	
72	120	2.93*	2.82*	2.56	2.76*	2.66*	2.42	2.42	2.32	2.06	
72	145	3.52*	3.39*	3.09	3.33*	3.20*	2.91	2.92	2.81	2.55	
72	170	4.11*	3.96*	3.61	3.89*	3.74*	3.41	3.42	3.29	2.98	
72	195	4.70*	4.53*	4.13	4.44*	4.28*	3.90	3.91	3.76	3.41	
72	220	5.28*	5.09*	4.65	5.00*	4.82*	4.39	4.40	4.23	3.85	
ALS/CLS											
38	89	1.56	1.47	1.27	1.47	1.39	1.21	1.29	1.22	1.07	
38	114	2.21*	2.09*	1.82	2.05*	1.94	1.70	1.76	1.67	1.47	
38	140	2.76*	2.65*	2.40	2.60*	2.50*	2.23	2.25	2.14	1.89	
38	184	3.61*	3.47*	3.15	3.41*	3.27*	2.97	2.98	2.86	2.58	
38	235	4.60*	4.42*	4.01	4.33*	4.17*	3.78	3.79	3.64	3.29	
89	184	4.74*	4.57*	4.18	4.49*	4.33*	3.95	3.96	3.81	3.46	
89	235	6.00*	5.79*	5.30	5.69*	5.49*	5.01	5.03	4.84	4.41	

* Two additional joists required
Bold text = normal bearing increased to 50mm

Table 2: Permissible clear spans for domestic floor joists. Strength class C24

Imposed load not exceeding $q_k = 1.5 \text{ kN/m}^2$ or $Q_k = 2.0 \text{ kN}$. Service class 1 or 2.

Dead load g_k (kN/m ²) excluding self-weight of joist											
Size of joist		gk not more than 0.25			gk not more than 0.50			gk not more than 1.25			
		Joist spacing (mm)									
		400	450	600	400	450	600	400	450	600	
Breadth (mm)	Depth (mm)	Maximum clear span (m)									
38	95	1.99*	1.89*	1.64	1.86*	1.76	1.54	1.61	1.53	1.34	
38	120	2.64*	2.54*	2.27	2.49*	2.39*	2.11	2.14	2.03	1.80	
38	145	3.18*	3.06*	2.78	3.00*	2.88*	2.61	2.62	2.52	2.26	
38	170	3.72*	3.58*	3.25	3.51*	3.37*	3.06	3.07	2.95	2.67	
38	195	4.26*	4.10*	3.72	4.02*	3.86*	3.51	3.52	3.38	3.06	
38	220	4.79*	4.61*	4.19	4.52*	4.35*	3.95	3.96	3.81	3.45	
44	95	2.14*	2.02*	1.76	1.99*	1.89	1.65	1.71	1.63	1.44	
44	120	2.77*	2.67*	2.42	2.61*	2.51*	2.25	2.27	2.16	1.92	
44	145	3.34*	3.21*	2.92	3.15*	3.03*	2.75	2.76	2.65	2.40	
44	170	3.90*	3.76*	3.42	3.69*	3.54*	3.22	3.23	3.10	2.81	
44	195	4.47*	4.30*	3.91	4.22*	4.06*	3.68	3.70	3.55	3.22	
44	220	5.02*	4.84*	4.40	4.75*	4.57*	4.15	4.16	4.00	3.63	
47	95	2.20*	2.08*	1.82	2.05*	1.94	1.70	1.76	1.68	1.48	
47	120	2.83*	2.73*	2.48	2.67*	2.57*	2.32	2.33	2.22	1.97	
47	145	3.41*	3.28*	2.98	3.22*	3.10*	2.81	2.82	2.71	2.45	
47	170	3.99*	3.84*	3.49	3.77*	3.62*	3.29	3.30	3.17	2.87	
47	195	4.56*	4.39*	4.00	4.31*	4.15*	3.77	3.78	3.63	3.29	
47	220	5.13*	4.94*	4.50	4.85*	4.67*	4.24	4.26	4.09	3.71	
63	95	2.52*	2.43*	2.14	2.38*	2.26*	1.99	2.03	1.94	1.72	
63	120	3.11*	2.99*	2.72	2.94*	2.83*	2.57	2.57	2.47	2.22	
63	145	3.74*	3.60*	3.28	3.54*	3.40*	3.09	3.10	2.98	2.70	
63	170	4.37*	4.21*	3.84	4.13*	3.98*	3.62	3.63	3.49	3.17	
63	195	5.00*	4.81*	4.39	4.72*	4.55*	4.14	4.15	4.00	3.62	
63	220	5.61*	5.41*	4.94	5.31*	5.12*	4.66	4.68	4.50	4.08	
72	120	3.25*	3.13*	2.85	3.07*	2.96*	2.69	2.70	2.59	2.35	
72	145	3.91*	3.77*	3.44	3.70*	3.56*	3.24	3.25	3.13	2.84	
72	170	4.57*	4.40*	4.02	4.32*	4.16*	3.79	3.80	3.66	3.32	
72	195	5.22*	5.03*	4.59	4.94*	4.76*	4.34	4.35	4.19	3.81	
72	220	5.86*	5.65*	5.17	5.55*	5.35*	4.88	4.90	4.71	4.29	
ALS/CLS											
38	89	1.82*	1.72	1.50	1.71	1.62	1.41	1.49	1.41	1.24	
38	114	2.51*	2.41*	2.12	2.36*	2.24*	1.97	2.01	1.91	1.69	
38	140	3.07*	2.96*	2.68	2.90*	2.79*	2.53	2.53	2.43	2.17	
38	184	4.02*	3.87*	3.52	3.79*	3.65*	3.31	3.32	3.19	2.89	
38	235	5.11*	4.92*	4.47	4.83*	4.64*	4.22	4.23	4.06	3.68	
89	184	5.26*	5.08*	4.64	4.98*	4.81*	4.39	4.40	4.24	3.86	
89	235	6.65*	6.42*	5.88	6.31*	6.09*	5.57	5.58	5.38	4.90	

* Two additional joists required
Bold text = normal bearing increased to 50mm

6.4.9 Timber joist performance

Also see: Chapter 3.3

Floor joists shall be of an appropriate size and quality, and be suitably durable.

I-joists and metal web joists should not be used in situations where any part of the joist is exposed to external conditions, and be:

- in accordance with Technical Requirement R3
- used in accordance with the manufacturer's recommendations
- protected from adverse weather conditions during transport and storage
- stored clear of the ground and stacked vertically
- not used where damaged
- designed in accordance with BS EN 1995-1-1 and its UK National Annex.

Instantaneous deflection of floor joists should be:

- no more than $0.003 \times$ the span for the combined bending and shear based on the total dead and imposed loads, with a maximum deflection of 14mm where strutting is provided, or 12mm where strutting is not provided.

Floors formed by the bottom chords of attic trusses are required to meet the above guidance.

Structural solid timber joists should be specified according to the strength classes in BS EN 338, eg C16 or C24, and marked with:

- the strength class, or evidence of species and grade made available so as to determine the strength class
- the identification of the company responsible for the grading (when graded to BS 4978 or BS EN 14081).

When graded to BS 4978:

- the species should be included in accordance with BS EN 1912 or the class strength specified
- BS EN 338 can be used to determine strength class.

Regularised timber should be used for solid timber joists, and be:

- dry graded to BS 4978 or BS EN 14081
- marked 'DRY' or 'KD'.

Materials should be checked on delivery for conformity with the design.

Joists should be stored on bearers or in racks and be protected (see Figure 6).

Timber should not be used where:

- it is excessively bowed, twisted or cambered
- it has large edge knots or shakes
- it has a wane edge more than half the thickness
- it is damaged or has any sign of rot.

Figure 6: Timber stored on bearers clear off the ground

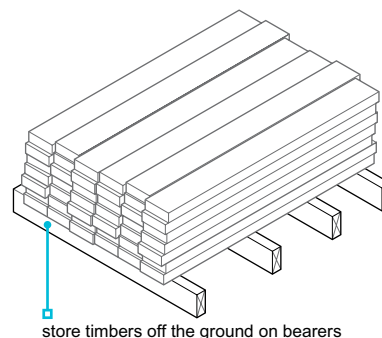

6.4.10 Construction of timber floors

Also see: Chapter 3.3

Upper floors shall be constructed in a workmanlike manner and provide satisfactory performance.

Issues to be taken into account include:

- 1) levelling
- 2) joist spacing and clearance
- 3) support.

6.4.10.1 Levelling

Bearings for joists should be level. The floor should be levelled:

- from the staircase trimmer and trimming joist
- in accordance with the manufacturer's recommendations
- using hard packing; loose or soft packing should not be used.

Figure 7: Level bearing of floor joists

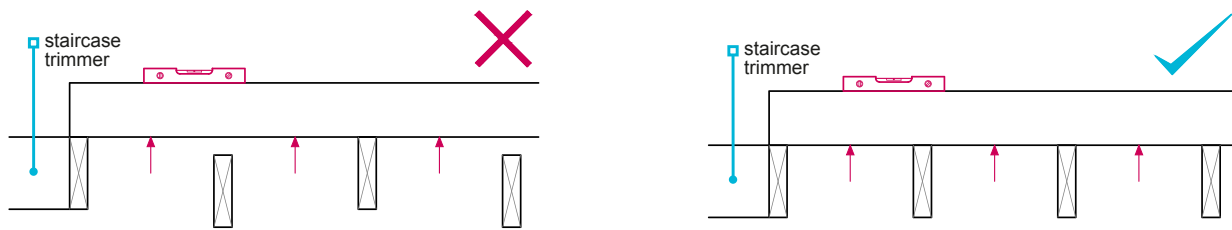

6.4.10.2 Joist spacing and clearance

Joist spacing should:

- be in accordance with the design and not increased
- account for the decking material to be used
- be a maximum of 600mm
- have a clearance of 25mm–75mm between the first joist and the wall face to aid the installation of services and the fixing of floor decking.

6.4.10.3 Support

The floor should have an adequate bearing on the supporting structure.

Timber joists should normally have a minimum bearing as shown in Table 3.

Table 3: Support of joists

Type of timber joist	Minimum bearing (mm)	
	End support	Intermediate support
Solid joist on masonry walls	90 (75)	90 (75)
Solid joist on timber wall plate	75	75
I-joist	90 (45)	90
Metal web joist	90 (45)	90

The figures in brackets should only be used when the joist is not providing restraint to the wall.

Joists may be:

- supported on joist hangers or on internal load-bearing walls
- built into the inner leaf of an external cavity wall, with care taken to ensure airtightness.

Where joists are built into separating walls, fire- and sound-resisting performance, in accordance with Building Regulations, should be taken into account.

I-joists and metal web joists

Where engineered joists are built into the inner leaf of a cavity wall, only proprietary products should be used to seal the gap between the sides of the joists and the masonry. Expanding foam fill should not be used or relied upon for this purpose.

I-joists and metal web joists should not be built into solid external walls.

The support reaction, due to dead and imposed loads on the floor, should not exceed the recommended value specified by the manufacturer.

Where there are concentrated loads:

- web stiffeners should be used for I-joists (see Figure 9)
- uprights between the flanges, held in place by punched metal plate fasteners or bottom chord (flange) support, should be used for metal web joists (see Figure 10)
- the manufacturer's recommendations should be followed.

Figure 8: Typical engineered floor joists

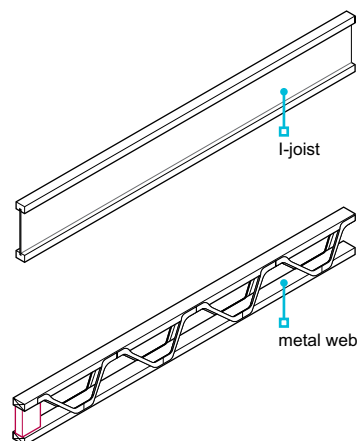

Figure 9: Typical web stiffeners on I-joists

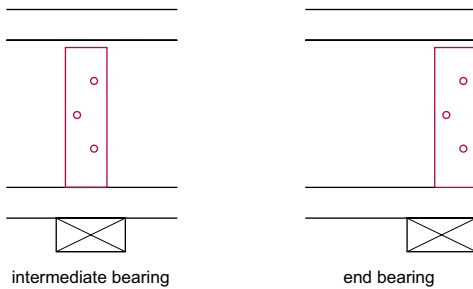
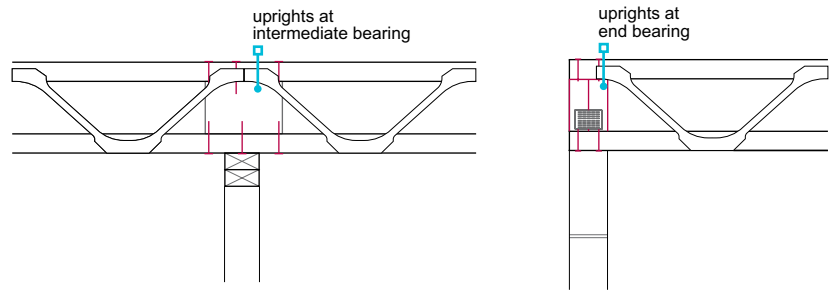

Figure 10: Typical bearing stiffeners on metal web joists



Where joists are supported on walls, noggings may be required at the top flange along the wall to support the floor decking, and at the bottom flange to support the plasterboard ceiling. Where joists are not built into brickwork or blockwork, blocking should be provided at the joist bearing (see Figures 11 and 12). The blocking may be used for fixing plasterboard and floor decking.

Figure 11: Blocking to restrain top flange of metal web joists

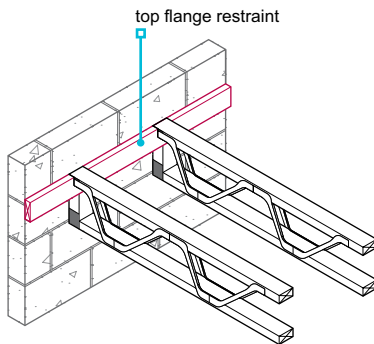
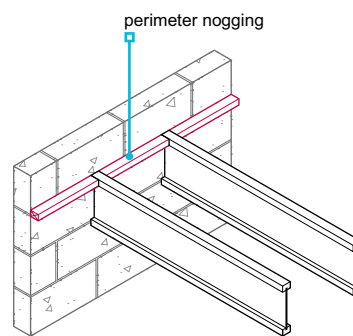

Figure 12: Blocking to restrain top flange of I-joists



6.4.11 Joists supported by intermediate walls

Joists shall be properly fixed at intermediate load-bearing walls.

Solid timber joists

Solid timber joists bearing onto intermediate load-bearing walls (see Figure 13) should:

- be nailed together where they overlap
- not project more than 100mm.

I-joists

I-joists bearing onto intermediate load-bearing walls (see Figure 14) should have:

- blocking used to brace the butt joint
- short sections of joist used to provide lateral support.

Metal web joists

Metal web joists bearing onto intermediate load-bearing walls (see Figure 15) should:

- have a minimum 90mm bearing
- be overlapped.

Figure 13: Solid joists supported on internal load-bearing wall

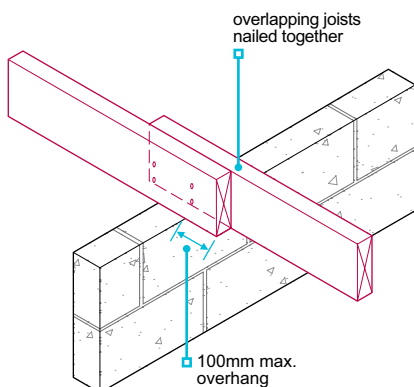

Figure 14: I-joists supported on internal load-bearing wall

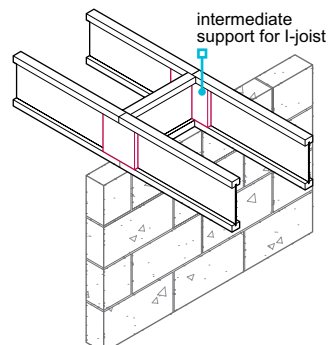
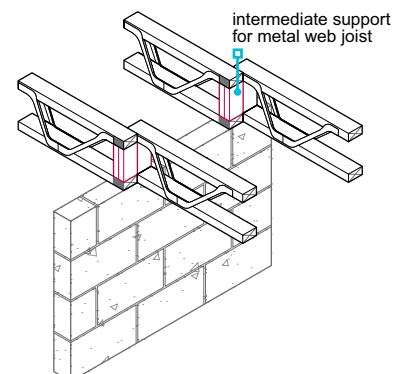

Figure 15: Metal web joists supported on internal load-bearing wall



6.4.12 Joists connected to steel

Joists shall be suitably connected to steelwork.

Solid timber joists

Where connected to steel beams, solid timber joists should:

- be deep enough to be notched
- have 12mm top and 2mm bottom projections to allow for timber shrinkage (see Figure 16)
- be provided with strutting to prevent rotation (see Figure 17).

Figure 16: Notching of solid timber joist into steel beam

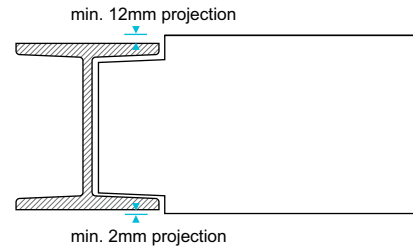

I-joists

Where connected to steel beams, I-joists should not be notched at the flange, and should:

- bear directly into the steel beam where the bearing is more than 45mm. Strutting, (noggings 38mm x thickness of flange) should be provided at the top and bottom flanges, or
- have blocking fixed to the steel beam to enable the I-joists to be face fixed using joist hangers. Strutting is not required when hangers the full depth of the joist are used to face fix joists to the blocking (see Figure 18).

Metal web joists

Where connected to steel beams, metal web joists should not be notched at the flange, and should:

- bear directly into the bottom flange of the steel beam where the bearing is more than 75mm. There should be timber uprights between the flanges and 38mm x 97mm noggings between the uprights
- where the bearing is less than 75mm, the joist can be supported on the top flange with the bottom flange fixed to timber blocking supported inside the steel beam (see Figure 19).

Figure 17: Strutting of solid joists notched into steel beam

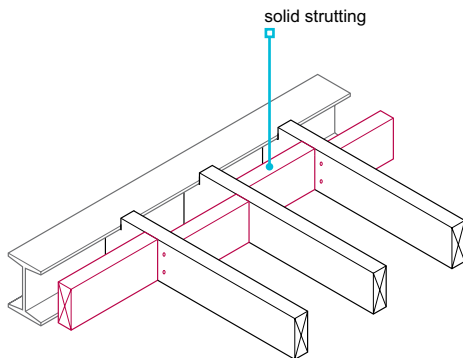

Figure 18: I-joist supported on timber blocking fixed to web of steel beam

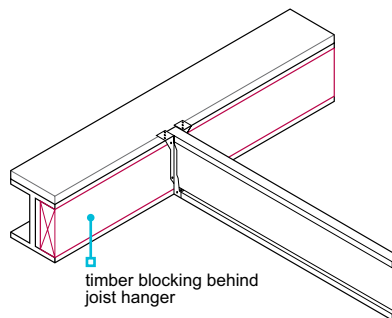
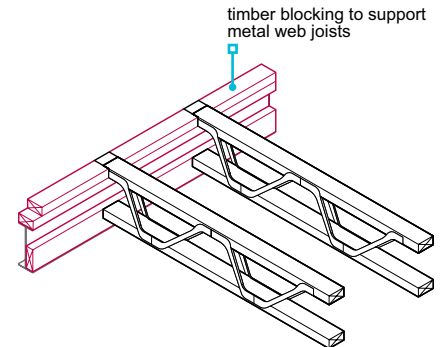

Figure 19: Metal web supported on top flange of steel beam



6.4.13 Joists into hangers

Joist hangers shall provide a suitable bearing on the supporting structure and be of an adequate size, strength and durability.

Masonry supporting joist hangers should be checked for level and height. The top flange loading on the joist hanger should not be greater than the strength of the supporting masonry. Where joist hangers are supported on lightweight blockwork, the suitability of the hanger should be checked. Joist hangers which meet BS EN 845-1 have a stamp indicating the minimum compressive strength of block for which they are suitable.

Hangers should:

- be detailed in the design, including the type of support to be used for joists, trimmers and trimming joists (see Figure 20)
- have a 75mm minimum bearing on masonry
- comply with BS EN 845-1 or another acceptable clause described in Technical Requirement R3
- have performance equivalent to restraint straps at 2m centres where required to provide restraint
- be the correct size for the joist or trimmer
- be nailed through each circular hole in the vertical sides
- bear on level beds and be tight to the wall
- not be cut into the walling.

Joists should be accurately cut to length. Where joists are not built into brickwork or blockwork, blocking should be provided at the joist bearing (see Figure 22). The blocking may be used for fixing plasterboard and floor decking.

Solid joists

Where connected to hangers, solid timber joists should:

- have a minimum bearing of 75mm onto the hanger
- be notched into the hanger to keep the ceiling line level (see Figure 21)
- be the full depth of the hanger.

I-joists

Where connected to hangers, I-joists should not be notched at the flange, and should have:

- a minimum bearing of 45mm onto the hanger
- the tabs of the hanger bent and nailed to the bottom flange (see Figure 23).
- at least 0.6 x the depth of the joist and have stiffeners (full depth) fixed to both sides of the web.

Metal web joists

Where connected to hangers, metal web joists should not be notched at the flange, and should have:

- a minimum bearing of 75mm onto the hanger
- timber uprights fixed between the flanges.

Hangers should be to the full depth of the joist and restrain the top flange, or another suitable means of restraining the top flange should be provided (see Figure 24).

Figure 20: Types of joist hangers

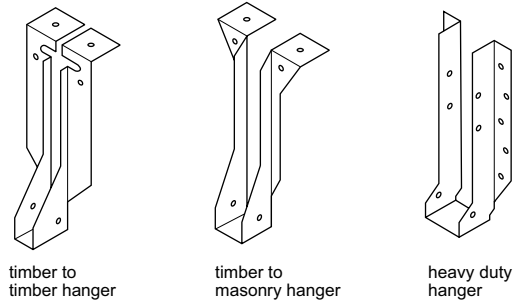

Figure 21: Solid timber joist supported on hanger

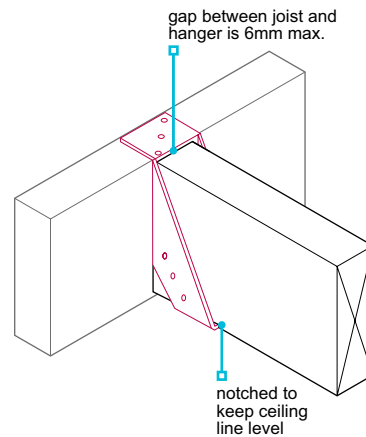

Figure 22: Blocking of solid joists supported on hanger

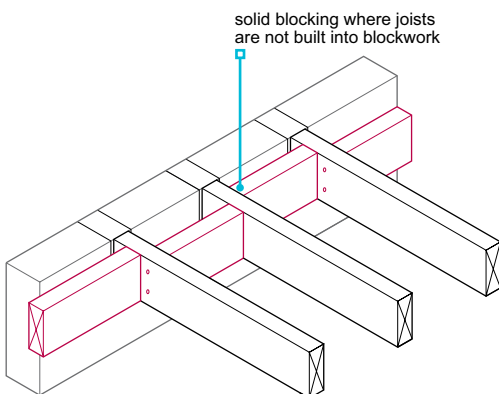

Figure 23: I-joist supported on hanger

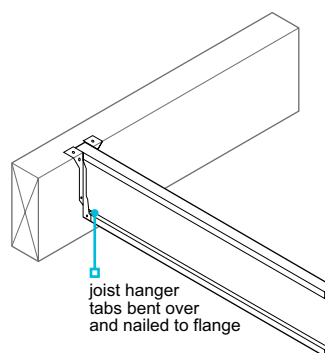
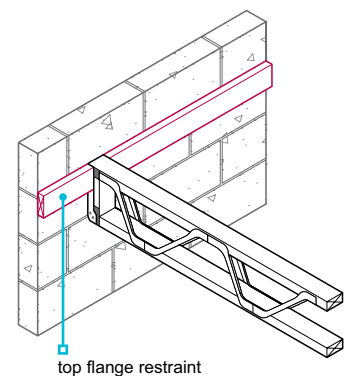

Figure 24: Blocking of metal web joists supported on hanger



6.4.14 Timber joist and restraint straps

Also see: Chapter 6.1 and BS 8103-1

Upper floors shall provide adequate lateral restraint.

Restraint straps and joist hangers suitable for taking tensile forces may be required to tie walls and upper floors together, or when the external wall is stabilised by a connection to the floor. Straps (see Figures 25 and 26) should:

- be detailed in the design, including the size, position and fixings
- be galvanised steel with a 30mm x 5mm cross-section or be in accordance with Technical Requirement R3
- have adequate packing between the wall and the first joist
- bear on the centre of bricks or blocks and not on mortar joints
- be fixed on the side, top or bottom, as appropriate to the joist type.

Figure 25: Side fixing of restraint straps to floor joists

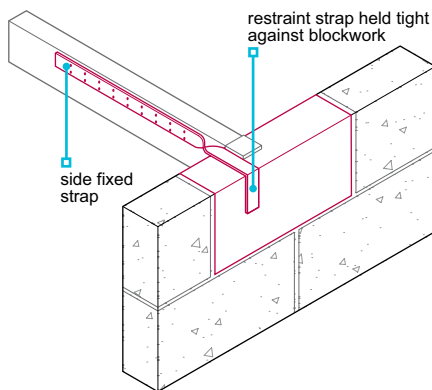
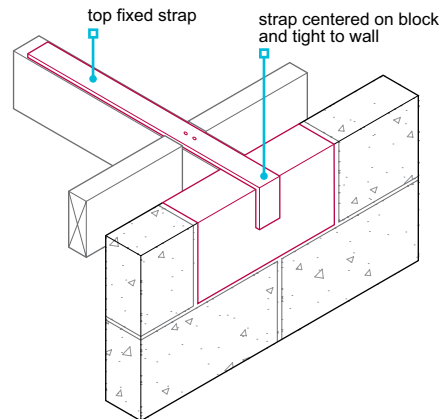

Figure 26: Top fixing of restraint straps to floor joists



Restraint straps should be provided along the direction of the joists and spaced at a maximum of 2m centres (see Figure 27). They are not generally required at the ends of joists in buildings up to, and including, two storeys where:

- restraint type joist hangers in accordance with Technical Requirement R3 are used, or
- joists are built into a wall and bear at least 90mm on the wall.

Where joists run parallel to the wall, straps should be fitted along the joists with a maximum spacing of 2m (see Figure 28) and:

- be supported on noggings and extend over at least three joists
- be fixed with two screws or nails into each joist
- have noggings provided to receive two additional nails (for solid joists, two 4.76mm diameter x 50mm long wood screws (No.10) or 4mm diameter x 75mm round nails (8 SWG) can be used in each joist).

Figure 27: Restraint strap required with use of non-restraint joist hangers

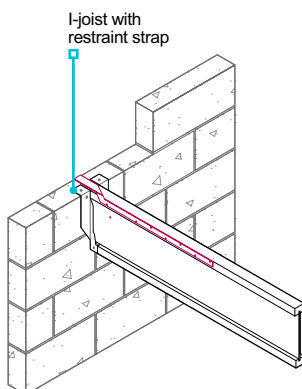
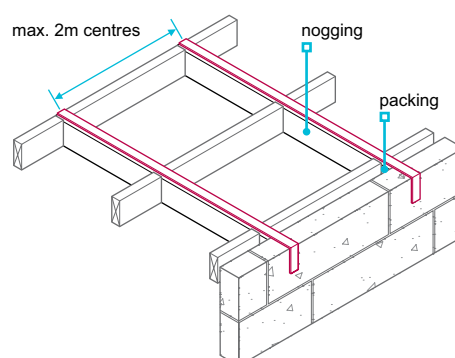

Figure 28: Restraint strap fixed to solid timber joists parallel to external wall



Solid timber joists

Solid timber joists should have noggings provided at:

- a minimum of 0.5 x the depth of the member when straps are located on top of the joist, or

I-joists

I-joists should not be notched and have:

- solid timber noggings no less than 0.5 x the depth of the member and a maximum of 150mm fixed between the webs and located beneath the top flange, with the straps installed through small slots neatly cut through the top of the web of the joists (see Figure 30)

When nailing into laminated veneer lumber flanges:

- care should be taken to prevent splitting

Figure 29: Restraint strap fixed to I-joists parallel to external wall — through noggings set flush with top flange

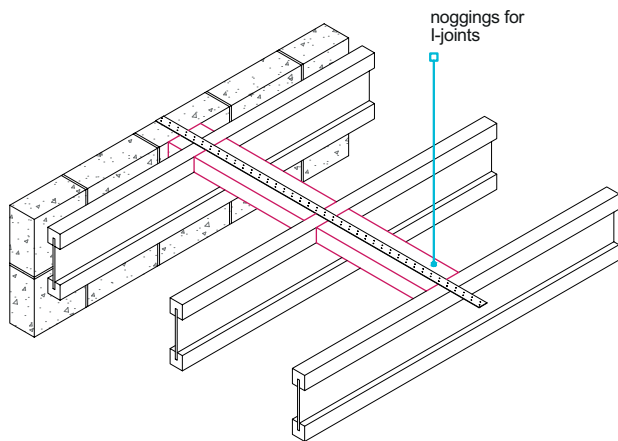

- the full depth of the member where straps are located beneath the joist.

- noggings made from short lengths of I-joist, or solid timber the full depth of the I-joists, or
- noggings half the depth of the member x depth of the flange laid on their side between the flanges (see Figure 29).

- nails should be driven in at an angle (not horizontally) and should not protrude from the flanges.

Figure 30: Restraint strap fixed to I-joists parallel to external wall — through slots cut in top of web

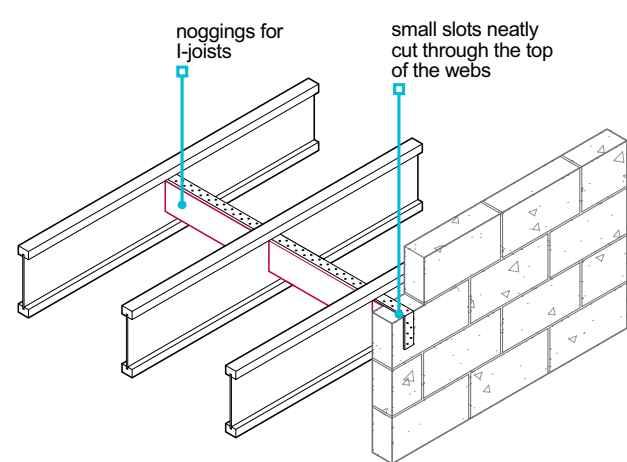

Metal web joists

Metal web joists should not be notched and should have:

- 35mm x 97mm solid timber noggings beneath the top flange of the metal web joists

- noggings nailed twice to each joist
- noggings should be butted tight to the wall.

Figure 31: Restraint strap fixed to metal web joists parallel to external wall

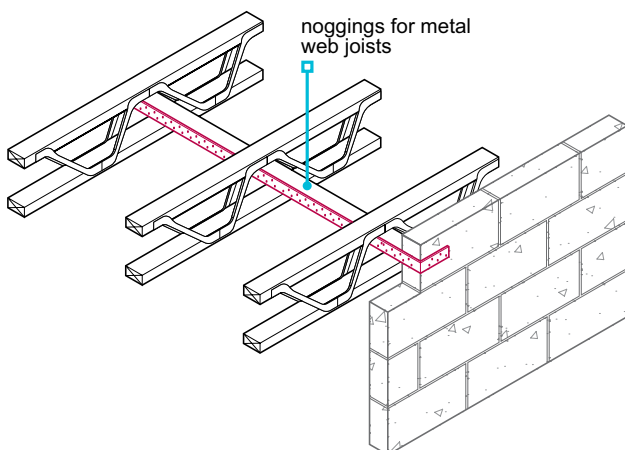

6.4.15 Strutting

Strutting shall be provided where required, in accordance with the design, to distribute loads and ensure adequate rigidity of the floor structure.

Strutting should:

- not project beyond the top and bottom edges of joists
- be firmly blocked to the wall at the end of each run
- be provided before the deck is laid.

Proprietary metal strutting should comply with Technical Requirement R3.

Strutting should be provided along the length of joists at intervals recommended in Table 4 or 5. These should be provided in addition to those required at support, depending on the type of support. The following are minimum provisions.

Solid timber and I-joists

Strutting to solid timber and I-joists should be:

- provided in accordance Table 4
- herringbone (38mm x 38mm timber) or solid blocking (minimum 38mm thick and 0.75 x the depth of the joist).

Figure 32: Typical strutting arrangement

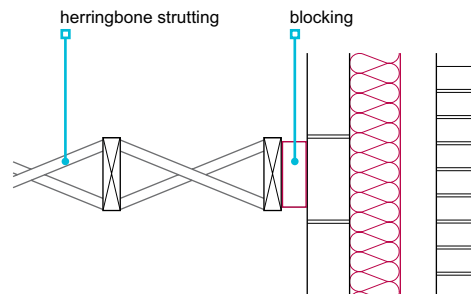

Table 4: Strutting for solid timber and I-joists

Joist span (m)	Rows of strutting
Under 2.5	None needed
2.5-4.5	1 (at centre of span)
Over 4.5	2 (at equal spacing)

I-joists

Strutting to I-joists should be:

- provided in accordance with the Table 4, where required.

Metal web joists

Strutting to metal web joists should be:

- provided in accordance with Table 5
- solid timber 'strongback' bracing (see Figure 33).

Figure 33: Strongback bracing

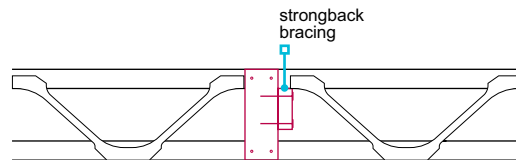

Table 5: Strutting for metal web joists

Joist span (m)	Rows of strutting
4-8	1 (at centre of span)
Over 8	2 (at equal spacing)

6.4.16 Joists and openings

Also see: Chapter 6.6

Upper floors shall have adequately sized and properly supported trimmer joists around openings.

Trimmer, trimmed and trimming joists should be:

- detailed in the design
- designed in accordance with Technical Requirement R5.

Connections between joists should be made with suitable 'timber-to-timber' hangers and:

- where face fixing I-joists to another I-joist, be provided with backer blocks on both sides of the web of the trimmer (see Figure 35)
- where metal web joists are used as a trimming joist to support another metal web joist, have timber uprights between the flanges of the trimmer (see Figure 36).

Figure 34: Trimming around openings in floors

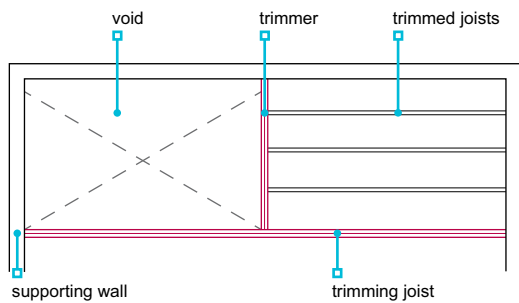

Figure 35: I-joist connection of trimmer and trimming joists

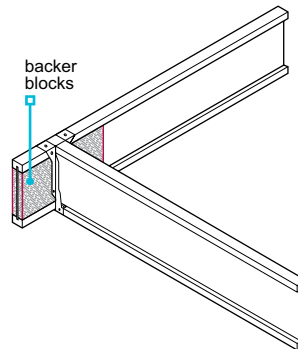
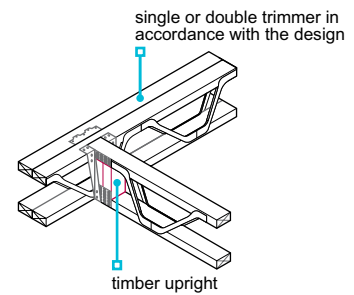

Figure 36: Metal web joist connection of trimmer and trimming joists



Deflection

The following should be considered in the design and detailing around openings in floors:

- deflection of trimming joists should be similar and no worse than the adjacent floor joists
- compound deflection of the floor, including trimming and trimmed joists, should be limited to the overall floor deflection, to ensure there is no differential movement or noticeable step in the floor level adjacent to the trimming joists
- where partition walls are built off trimmers and trimming joists, particularly fire compartment walls, additional care should be taken to ensure that the overall deflection of such joists would not result in residual gaps at the heads of the walls, or in distorted walls or openings within the walls.

There should be no notching or drilling of trimmers or trimming joists unless proven by design calculations.

6.4.17 Multiple joists

Multiple joists shall be securely fixed together.

Joists can be doubled or tripled up to provide additional support, eg for lightweight partitions or to form trimmers. The design should specify how the joists are fixed together and be in accordance with manufacturers' recommendations.

As a minimum, the fixing centres for double member trimmer and trimming joists should be at centres of no more than twice the adjacent joist spacing.

When securing solid joists:

- fixings should be in accordance with the engineer's specification and should be checked before the ceiling is fixed, including the tightness of bolts
- washers or single-faced connectors should be used with bolts
- toothed plate, split ring and shear plate connectors should be provided where required
- ensure that timber is not damaged by over-tightening.

Coach bolts can be used to fix multiple solid joists together. They could be located at centreline or staggered, depending on the loading and design. Where located on centreline, spacing of between S (joist centres) and 1.0m can be used. Where more than two joists are secured together, or a heavy concentrated load is to be supported, the fixing arrangement with staggered spacing shown in the table below may be used (see Figure 37).

Figure 37: Fixing of multiple solid joists

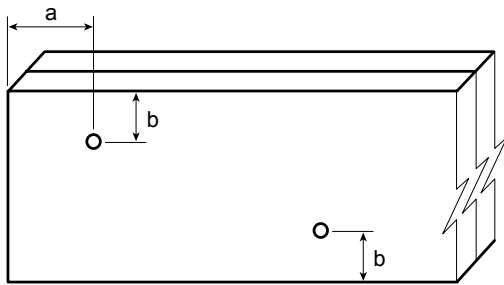
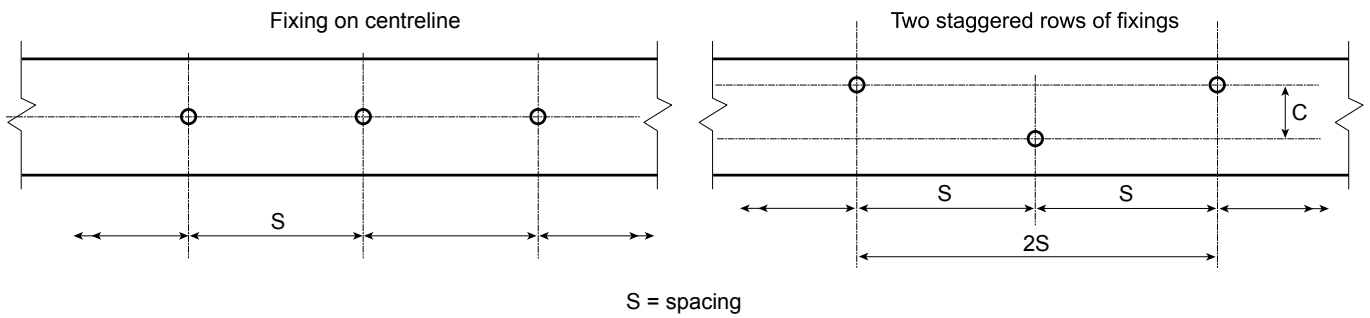

Fixing type	Minimum dimension (mm)		
	a	b	c
Bolt	Maximum of 7d or 80mm	4d	4d

d – diameter of bolt

Engineered joists should be secured together in accordance with the manufacturer’s recommendation.

Figure 38: Fixing of double I-joists

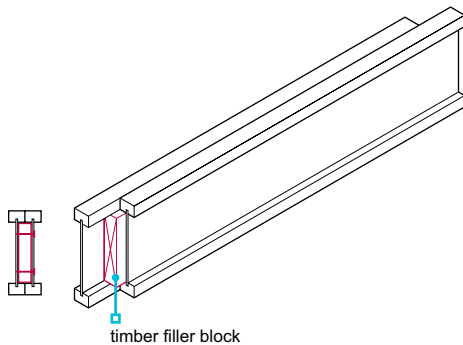

6.4.18 Notching and drilling

Notching and drilling shall be carried out within recognised limits.

Solid timber joists

Notching and drilling should be designed by an engineer where:

- the joist is deeper than 250mm
- it does not meet the guidelines in this chapter, or
- it is close to heavy loads, such as those from partitions, cisterns, cylinders and stair trimming.

Notching and drilling (see Figure 39) should:

- have a minimum horizontal separation of 100mm
- be in accordance with Table 6.

Table 6: Notching and drilling solid timber joists

	Location	Maximum size
Notching joists up to 250mm depth	Top edge 0.1-0.2 x span	0.15 x depth of joist
Drilling joists up to 250mm depth	Centre line 0.25-0.4 x span	0.25 x depth of joist

Figure 39: Notching and drilling requirements of solid joists

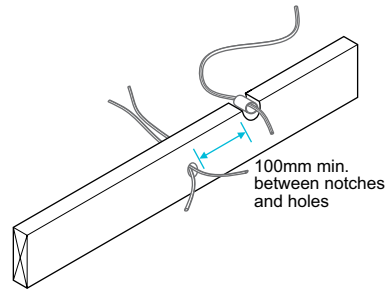
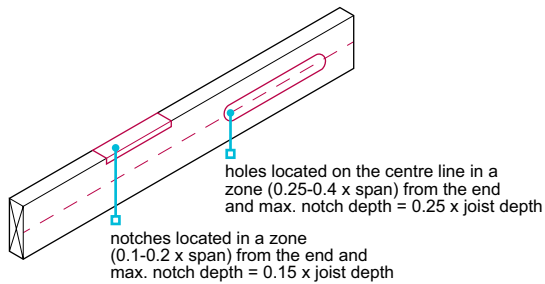
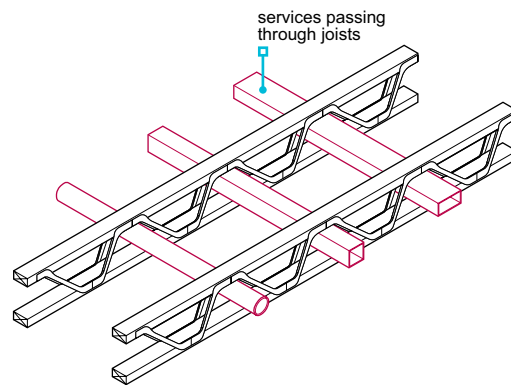

Figure 40: Service conduits in metal web joists



I-joists

Preformed holes should be provided in the web, and:

- holes or notches should not be cut without the approval of the manufacturer
- restraint straps can be slotted into webs immediately below the top flange.

Metal web joists

In metal web joists:

- service conduits should run in the gaps between the metal webs (see Figure 40)
- maximum duct sizes should be in accordance with the manufacturer's recommendations
- large service ducts may have to be inserted before fixing the joists, as it may not be possible after the joists have been fixed.

6.4.19 Floor decking

Floor decking shall be suitable for the intended use and be of adequate strength and moisture resistance. Issues to be taken into account include:

- 1) type, thickness and fixing
- 2) protection against damage.

6.4.19.1 Type, thickness and fixing

Where decking contributes to the sound insulation of a floor, the thicknesses listed in this chapter should be checked.

Floor decking should:

- be appropriate to the joist spacing
- be in accordance with Table 7 (which applies to normal domestic loads ie, an imposed load of 1.5kN/m²), or comply with another acceptable clause described in Technical Requirement R3.

Table 7: Floor decking requirements

Floor decking	400mm joist centres	450mm joist centres	600mm joist centres	Standard
Softwood boarding	16	16	19	BS EN 13353
Moisture-resistant chipboard	18	18	22	BS EN 312 — type P5
Plywood	15	15	18/19	BS EN 636
Oriented strand board	15	15	18/19	BS EN 300 — type OSB/3

When installing decking:

- fixings and support should be in accordance with the manufacturer's recommendations
- checks should be made, prior to fixing, to ensure that noggings, blocking and strutting are in the correct position and secure
- butt joints should be staggered and supported on noggings or joists
- adjacent boards should be square
- where nails are used, they should be 2.5 x the thickness of the decking material
- where gluing is required, boards should be glued to the joists and at joints, using a suitable polyvinyl acetate (PVAc) adhesive
- temporary wedges and packing should be removed once the floor decking is complete.

Square edged boards and boards with loose tongues

When fixing boards with square edges or loose tongues, they should be supported on all sides by joists or noggings (see Figure 41).

Tongued and grooved boards

When fixing boards with tongued and grooved edges:

- boards should be laid with long edges at right angles to joists
- short edges should be supported on joists or noggings or cut back to form a butt joint over a joist (see Figure 42)
- boards should be glued to the joists and the sheets glued to each other with PVAc adhesive (not softwood boarding)
- long edges at room perimeters should be fully supported on joists or noggings.

Chipboard flooring

Chipboard flooring should be supported and fixed in accordance with the manufacturers' recommendations, using either:

- flat-headed ring shank nails, 2.5 x the thickness of the board and minimum 3mm diameter, or
- screws to BS 1210, minimum 2 x the thickness of the board and no less than size No. 8.

Figure 41: Longitudinal support to square edged boards

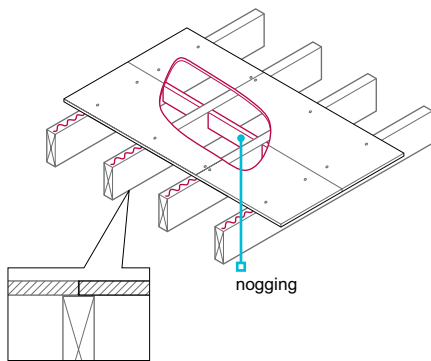

Figure 42: Short edges of floorboards supported on joists

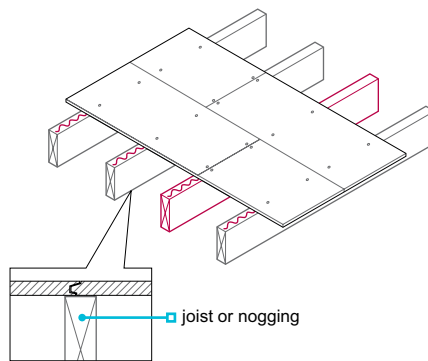
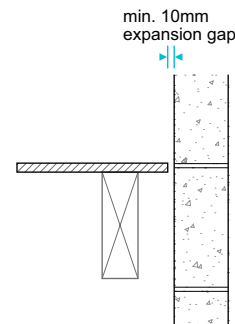

Figure 43: Floorboards abutting rigid upstands



When fixing:

- fixings should have a maximum spacing of 300mm along continuously supported edges and intermediate supports
- where boards abut a rigid upstand, a minimum 10mm expansion gap should be provided; for large areas of boarded floor, a wider expansion gap may be required at upstands, and intermediate expansion gaps of 2mm per linear metre of floor should be provided (see Figure 43).

Oriented strand board (OSB) flooring

When fixing OSB flooring:

- boards should be laid over supports in the direction indicated on the board, with the stronger axis at right angles to the supporting joists
- boards should be long enough to span two joists
- nails should be flat headed and annular grooved nails, 3mm in diameter
- where boards abut a rigid upstand, a minimum 10mm expansion gap should be provided; for large areas of boarded floor, a wider expansion gap may be required at upstands, and intermediate expansion gaps of 2mm per linear metre of floor should be provided.

Plywood flooring

When fixing plywood flooring:

- boards should be laid with the face grain at right angles to the supports
- end joints should occur over joists or noggings
- fixings should have a maximum spacing of 150mm around the perimeter and a maximum spacing of 300mm on intermediate supports
- an expansion gap of at least 1.5mm-2mm should be allowed between each panel.

Nails for fixing plywood should be in accordance with Table 8.

Table 8: Fixings for plywood floors

	Plain wire nails (mm)	Annular ring shank nails (mm)
Minimum diameter	3.35	3
Minimum length	65	50
Minimum penetration	40	32

Proprietary flooring

Proprietary flooring should be:

- certified in accordance with Technical Requirement R3
- installed in accordance with certification requirements.

6.4.19.2 Protection against damage

Floor decking should be stored:

- on a hard base
- under cover
- indoors where possible.

Floor decking that is built in as the work proceeds and left exposed to the weather will be subjected to deterioration and adverse effect of the weather, particularly when exposed to prolonged periods of rainfall. Such floor decking, when used in conjunction with engineered and traditional joists, should:

- have a third-party approval certificate from a UKAS accredited body which covers weather resistance for the period of time the boards are to be left exposed on site
- be used strictly in accordance with the manufacturer's instruction and details.

Any floor decking that is left exposed beyond the period stated on the third-party approval certificate should be replaced.

Non-proprietary floor decking without third-party certification should not be used on structural floors exposed to the weather for any period of time, under any circumstances.

Floors should not be overloaded, especially with materials during construction, and be protected against damp, plaster splashes and other damage.

6.4.20 Floating floors or floors between homes

Floating floors shall be separated from the main structure and surrounding walls by a resilient layer.

The structural component of floors between homes may be concrete, steel, timber or a combination of these materials.

The floor finish should be isolated from walls and skirtings.

Where board materials are laid loose, joints in tongued and grooved boards should be glued.

Proprietary floating floor materials and systems should be fixed in accordance with:

- Building Regulations
- manufacturer's recommendations
- relevant certification requirements.

6.4.21 Further information

- *BS8103-1 — Structural design of low-rise buildings. Code of practice for stability, site investigation, foundations, precast concrete floors and ground floor slabs for housing*
- *BM Trada Tables — Eurocode 5 span tables for solid timber members in floors, ceiling and roofs for dwellings by BM TADA Technology Ltd. 4th Edition*



Chapter 6.5



Steelwork

This chapter gives guidance on meeting the Technical Requirements for:

- steelwork which supports masonry partitions and timber floors, including trimmed openings
- the protection of steelwork.

6.5.1	Compliance	02
6.5.2	Design guidance	02
6.5.3	Steel grade and coatings	04
6.5.4	Installation and support	06
6.5.5	Padstones	06
6.5.6	Connections	07
6.5.7	Examples	08



Figure reference table

Figure Reference Table 6.5

Fig No	Title/Description	Clause	Page
Figure 1	Allowing for shrinkage of timber joists	6.5.2.2	3
Figure 2	Effective areas supported by steel beams	6.5.2.2	3
Figure 3	Joints between beams of similar size (beams 170mm to 230mm deep)	6.5.6	7
Figure 4	Joints between beams of similar size (neither beam deeper than 170mm)	6.5.6	7
Figure 5	Example	6.5.7	8

6.5.1 Compliance

Also see: Chapter 2.1

Steelwork shall comply with the Technical Requirements.

Steelwork (including trimming to floor voids) for supporting masonry partitions or timber floors which comply with the guidance in this chapter will generally be acceptable.

The information provided in this chapter is in accordance with BS EN 1993-1-1 using grade S275 steel; however, more economical or smaller beams may be designed by an engineer.

Steelwork, including its support and any connections, should be:

- designed by an engineer in accordance with Technical Requirement R5, or
- detailed in accordance with this chapter.

6.5.2 Design guidance

Also see: Chapters 6.1, 6.3 and 6.4

Steelwork shall be designed to support and transmit loads to the supporting structure without undue movement or deflection. Issues to be taken into account include:

- 1) support of masonry partitions
- 2) support of timber floors, including trimmed openings.

6.5.2.1 Support of masonry partitions

Masonry partitions may be supported by steelwork selected in accordance with this chapter. Care should be taken to avoid masonry supported by steelwork being partially supported or out of true.

Conditions for Tables 1 and 2

Steel beams in accordance with Tables 1 and 2 of this chapter will generally be acceptable for the support of masonry partitions where the following conditions are met:

- the partition is of one of the types detailed in Table 1
- the partition is built centrally on the steelwork beam and is less than 2.7m in height
- the span of the steel beam is less than 4m
- steel beams only support the weight of the partition and self-weight
- brickwork or blockwork (workface size 440mm x 215mm) supporting the steel beam has a minimum strength of 2.8N/mm² and the beam supports do not occur over a door or window opening
- padstones are provided where required, in accordance with Table 6.

Where any of the conditions are not met, steelwork should be designed in accordance with Technical Requirement R5.

Method of applying tables:

- ensure that all conditions apply
- identify the masonry partition construction and thickness
- use Table 1 to establish the load per metre run
- check the span of the beam(s)
- use Table 2 to determine a suitable steel section size
- use Table 6 to determine if padstones are required.

An example is provided at the end of this chapter.

Table 1: Load of partition to be supported

Type of masonry for supported partition (not more than 2.7m high and plastered both sides)	Maximum masonry density (kg/m ³)	Structural thickness (mm)		
		100	90	75
		Load (kN/m run)		
Dense masonry	2,000	6.8	6.2	5.4
Medium masonry	1,400	5.1	4.8	4.2
Lightweight masonry	800	3.5	3.3	2.9

Table 2: Size of steel beam supporting partition

Partition load (from Table 1) (kN/m run)	Clear span of beam (m)	Smallest suitable universal beam size (mm x mm x kg/m)
Less than 3	Up to 4 Over 4	127 x 76 x 13 (2)
3 to 5	Up to 3 3 to 3.5 3.5 to 4 Over 4	127 x 76 x 13 152 x 89 x 16 178 x 102 x 19 (2)
5 to 7	Up to 2.5 2.5 to 3 3 to 4 Over 4	127 x 76 x 13 152 x 89 x 16 178 x 102 x 19 (2)

Notes

- For spans up to 4m, universal column 152mm x 152mm x 23kg/m (smallest size available) may be used.
- For spans over 4m, beams should be designed by an engineer in accordance with Technical Requirement R5.

6.5.2.2 Support of timber floors, including trimmed openings

Timber floors may be supported by steelwork selected in accordance with this chapter and should include full allowance for the shrinkage of timber joists.

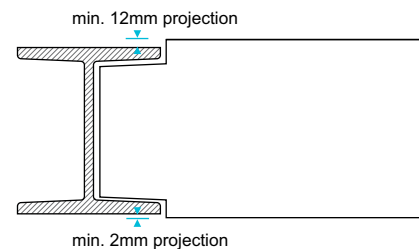
Figure 1: Allowing for shrinkage of timber joists

Conditions for Tables 3 and 7

Steel beams in accordance with Tables 3 and 7 will be acceptable to NHBC for the support of floors, where the following conditions are met:

- the floor construction is of decking (softwood boarding, chipboard, oriented strand board or plywood) on timber joists and the ceiling is plasterboard with a plaster skim coat or a plastic finish (Artex or similar)
- allowance has been made of 0.5kN/m² for self-weight (floor and ceiling load)
- the floor does not support masonry partitions
- any lightweight partition, such as plasterboard on timber studwork or proprietary product, is non load-bearing
- padstones are provided where required in accordance with Table 6
- clear span of beam does not exceed 4.4m
- connections between steelwork beams are in accordance with Clause 6.5.6, or are designed by an engineer
- the floor support is one of the methods shown in Figure 1.

Where any of the conditions are not met, steelwork should be designed by an engineer in accordance with Technical Requirement R5.

Method of applying tables:

- use Figure 1 to determine the area supported by the beam(s)
- check the span of the beam(s)
- use Table 3 to determine a suitable steel section size
- use Table 7 to determine if padstones are required
- where steel beam-to-steel connections are required, refer to the connections in Clause 6.5.6.

Ensure that all conditions apply.

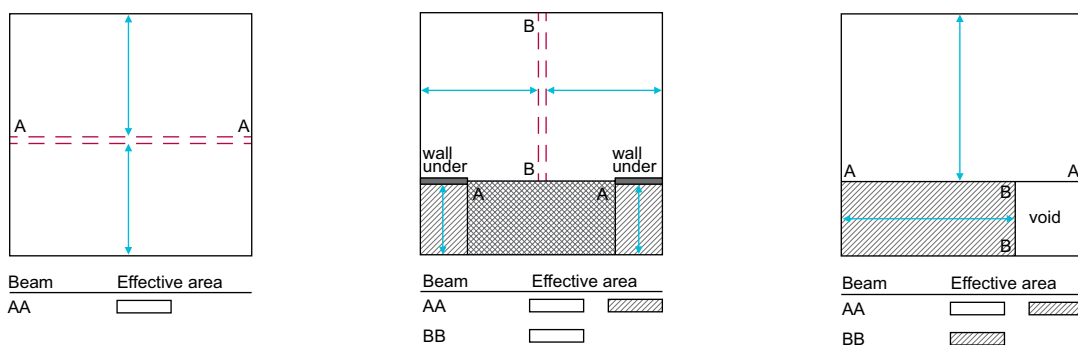
Figure 2: Effective areas supported by steel beams

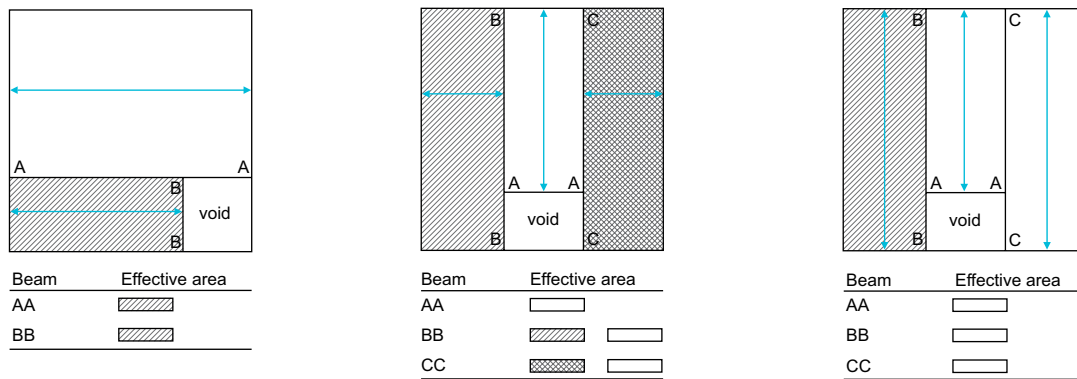

Where any area shown as 'void' contains a staircase, add 2m² to the effective area supported by any beam which fully or partially supports that staircase.

Table 3: Size of steel beam supporting timber floor

Effective area supported (m ²)	Effective trimmer span = clear span + 100mm (m)	Smallest suitable steel section size (mm x mm x kg/m)	
		Universal beam	Universal column
0 to 20	0 to 2.0	127 x 76 x 13	152 x 152 x 23
0 to 20 20 to 30	2 to 2.5	127 x 76 x 13 152 x 89 x 16	152 x 152 x 23 152 x 152 x 23
0 to 10 10 to 20 20 to 30	2.5 to 3	127 x 76 x 13 152 x 89 x 16 178 x 102 x 19	152 x 152 x 23 152 x 152 x 23 152 x 152 x 23
0 to 10 10 to 30 30 to 40	3 to 3.5	127 x 76 x 13 178 x 102 x 19 203 x 133 x 25	152 x 152 x 23 152 x 152 x 23 152 x 152 x 30
0 to 10 10 to 20 20 to 30 30 to 40 40 to 50	3.5 to 4	152 x 89 x 16 178 x 102 x 19 203 x 102 x 23 203 x 102 x 30 *	152 x 152 x 23 152 x 152 x 23 152 x 152 x 23 152 x 152 x 30 152 x 152 x 37
0 to 10 10 to 20 20 to 30 30 to 40 40 to 50	4 to 4.5	203 x 102 x 23 203 x 133 x 25 203 x 133 x 30 * *	152 x 152 x 23 152 x 152 x 23 152 x 152 x 30 152 x 152 x 37 203 x 203 x 46

*Beams should be designed by an engineer in accordance with Technical Requirement R5.

6.5.3 Steel grade and coatings

Steelwork shall be specified to provide sufficient strength, durability and fire resistance.

The design should detail the method of fixing or connecting structural steelwork. The guidance given in this chapter applies to steelwork which is to be bolted (using black bolts) or not connected.

Steelwork should be in accordance with the guidance in this chapter and:

- BS EN 10365 Hot rolled steel channels, I and H sections. Dimensions and masses, or
- BS EN 10056 Structural steel equal and unequal leg angles - Dimensions.

To ensure adequate durability in the environment it will be exposed to, steelwork should:

- have a protective coating system applied before being delivered to site
- comply with the level of fire resistance required by Building Regulations.

Where welding is to be carried out, the protective coating system specified by the designer should be used.

Further guidance on the protection of structural steel is given in BS EN ISO 12944 Paints and varnishes. Corrosion protection of steel structures by protective paint systems and BS EN ISO 14713 Zinc coatings. Guidelines and recommendations for the protection against corrosion of iron and steel in structures.

Decorative finishes should be compatible with the protective coat specification. The designer should determine compatibility in accordance with the manufacturer's recommendations. Chapter 9.5 Painting and decorating contains further guidance for decorative paint finishes to steelwork.

Table 4: Environment categories for component groups in different locations and exposure conditions

Component group	Location	Description of exposure condition	Environment categories
External	Outside a home	Above splash zone	C4 or C5 ⁽¹⁾
		At ground level within splash zone (up to 150mm above ground)	C5 ⁽²⁾
	Outside or basement	Below ground level	C5 ⁽²⁾
Internal	Sub-floor void ⁽³⁾	Unventilated	C3
		Ventilated	C2
Internal	Kitchen/bathroom, etc	Moist humid conditions — protected against condensation	C2
	Kitchen/bathroom, etc	Moist humid conditions — exposed to condensation	C2
	Rooms other than kitchen/bathroom, etc	Warm dry	C2
	In roof void	Unheated dry	C2
Internal/external	Façade	Embedded or partially embedded in building envelope	C5 ⁽⁴⁾

Notes

- For construction located within 500m of coastal shoreline.
- Alternatively, steelwork may be encased in concrete.
- For steelwork not in contact with the ground.
- For steelwork in contact with, or embedded in, an external masonry wall, for at the contact / embedment length.

Alternatively, guidance on suitable atmospheric corrosivity categories (C1–C5) and appropriate protective coatings for domestic construction may be based on the recommendations given on the website www.steelconstruction.info. A site-specific assessment is required in order to determine an appropriate classification level for the steelwork. A suitable protective coating specification is to be determined by the designer in accordance with the coating manufacturer's recommendations.

Table 5: Protective coatings for hot rolled structural steelwork for atmospheric corrosivity category (recommended for housing applications only)

Atmospheric corrosivity and risk	Surface preparation ⁽⁴⁾	Protective coating ^(1, 2, 3)			Site or factory applied	Making good of damaged areas of protective coating
		Material	Minimum coating thickness (d.f.t.) ⁽⁵⁾ / weight ⁽⁶⁾	Number of coats		
C1 Very low	N/A	None required	N/A	N/A	N/A	N/A
C2 Low	Thoroughly clean surface prior to abrasive blast cleaning to Sa 2½	High build zinc phosphate epoxy primer ⁽⁷⁾	80 µm ⁽⁸⁾	1 or 2	Factory	Thoroughly wire brush damaged areas and build up coats using the same materials and to the same d.f.t.
C3 Medium	Thoroughly clean surface prior to abrasive blast cleaning to Sa 2½	High build zinc phosphate epoxy ⁽⁷⁾ primer, followed by high build recoatable epoxy micaceous iron oxide (MIO)	80 µm ⁽⁸⁾ 120 µm (200 µm in total)	1 or 2 1	Factory	Thoroughly wire brush damaged areas and build up coats using the same materials and to the same d.f.t.
C4 High		Hot dip galvanize to BS EN ISO 1461 ⁽⁹⁾	460 gms/m ²	1	Factory	To be determined by the designer in accordance with the manufacturer's recommendations
C5 Very high		Hot dip galvanize to BS EN ISO 1461 ⁽⁹⁾	710 gms/m ²	1	Factory	To be determined by the designer in accordance with the manufacturer's recommendations

Notes

- Where steelwork is to be given a decorative finish, the protective coat is to be compatible with the decorative finish. Manufacturers' recommendations should be followed.
- Where steelwork is to be protected by intumescent paint for fire purposes, manufacturers' recommendations should be followed.
- All fixings and fittings to the structural steel elements are to be protected against corrosion in a manner that is both commensurate and compatible with the protective coatings.
- Surface preparation to BS EN ISO 12944-4.
- Coating thicknesses given represent nominal dry film thickness (d.f.t.).
- Thicknesses and weights shown represent the coating to be applied to each face of a steel section.
- Epoxy primers have a limited time for over-coating. Manufacturers' recommendations should be followed.
- 80 µm can be in one coat or as 20 µm pre-fabrication primer plus 60 µm post-fabrication primer.
- Alternatively, use products manufactured from austenitic stainless steel in accordance with the recommendations of BS EN 1993-1-4:2006.

Where shop-applied protective coatings have been damaged, the coatings should be made good on site prior to being built into the works, as indicated in Table 5 Making good of damaged areas of protective coating.

Where steelwork is to be welded, the protective coating system specified by the designer should be used.

Where steelwork is to be protected by intumescent paint for fire purposes, this should be in accordance with the manufacturer's recommendations.

6.5.4 Installation and support

Steelwork shall be installed to achieve the required structural performance. Issues to be taken into account include:

- 1) section size and grade detailed in the design
- 2) steelwork support.

6.5.4.1 Section size and grade detailed in the design

When materials are delivered to site, they should be checked to ensure conformity with:

- engineer's design, or
- steelwork sizes in this chapter.

6.5.4.2 Steelwork support

Beam supports should not occur above window or door openings. Bearings for steelwork supported on masonry should be:

- 100mm minimum
- clean, dry and level.

6.5.5 Padstones

Steelwork shall be supported by padstones where required to distribute point loads safely to the supporting structure without undue movement or deflection.

Where a steel beam is supported by masonry, a padstone may be required to spread the load over a larger area to prevent overstressing. Padstones should be in accordance with:

- the engineer's design, or
- the guidance given in this chapter.

Where the inner leaf of the cavity wall contributes to the overall thermal performance of the wall, padstones should:

- have similar thermal properties to the masonry used for the rest of the inner leaf, or
- not create a cold bridge.

Table 6: Size of padstones (for steel supporting partition walls)

Type of masonry for supported partition (not more than 2.7m high and plastered both sides)	Thickness of wall supporting beam (mm)						Minimum depth of padstone (mm)
	100	125	140	150	190	215	
	Minimum length of padstone (mm)						
Dense masonry	215	190	185	180	165	155	150
Medium masonry	155	140	135	130	120	110	150
Lightweight masonry	95	85	80	75	70	70	150

Notes

1. Padstones are not necessary where the flange dimension of the beam exceeds the length of the padstone given in this table.
2. When steelwork is in line with the wall supporting it ie, when acting as a lintel over an opening:
 - the flange dimension of the beam should not be more than 50mm greater than the thickness of the supporting wall
 - the minimum length of padstone should be 200mm
 - the padstone depth should match the coursing of adjacent masonry
 - the web of the beam should be over the centre of the wall.
3. The minimum length of steel bearing onto padstone should be 100mm.

Table 7: Size of padstones (for steel supporting floors)

Effective area supported (as used in Table 3) (m ²)	Minimum padstone size (mm)					
	Thickness of wall supporting steel beam (mm)					
	Up to 105		105 to 155		156 to 216	
	Length	Depth	Length	Depth	Length	Depth
Up to 10	95	150	80	150	70	150
10 to 20	185	150	160	150	140	150
20 to 30	275	150	240	150	210	150
30 to 40	365	215	320	150	280	150
40 to 50	455	300	400	215	345	215

Notes

- Padstones are not necessary where the flange dimension of the beam exceeds the length of the padstone given in this table.
- When steelwork is in line with the wall supporting it, ie, when acting as a lintel over an opening:
 - the flange dimension of the beam should not be more than 50mm greater than the thickness of the supporting wall
 - the minimum length of padstone should be 200mm
 - the padstone depth should match the coursing of adjacent masonry, and
 - the web of the beam should be over the centre of the wall.

Padstones should be formed in one unit with a minimum compressive strength of 10 N/mm² from:

- in-situ concrete
- precast concrete
- concrete blocks
- clay bricks, or
- engineering bricks (when less than 215mm x 100mm).

6.5.6 Connections

Connections shall be chosen and installed to achieve the required structural performance.

Steelwork connections should:

- be in accordance with the guidance in this chapter, or
- where other forms of connection (eg high-strength friction grip bolts) are required, be designed by an engineer in accordance with Technical Requirement R5.

Only weld, cut or drill steelwork where it is required by the design.

Bolts for connections should comply with the design information and relevant British Standards, including:

BS 4190	Specification for ISO metric black hexagon bolts, screws and nuts
BS EN 1011	Welding. Recommendations for welding of metallic materials
BS EN 14399	High-strength structural bolting assemblies for preloading
BS EN 1993-1-8	Eurocode 3. Design of steel structures — design of joints

The connection methods detailed in this chapter are suitable for connecting steel beams used to support floor loads only, using black bolts or welding.

Figure 3: Joints between beams of similar size
(beams 170mm to 230mm deep)

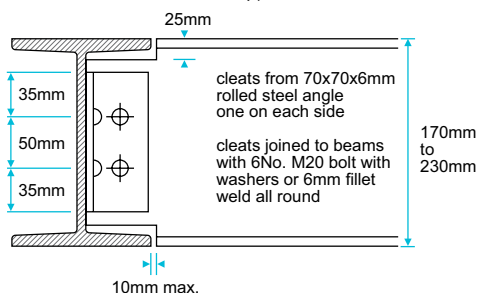
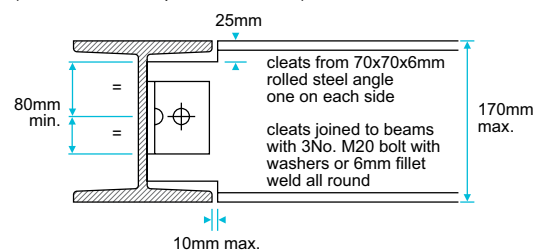

Figure 4: Joints between beams of similar size
(neither beam deeper than 170mm)



Conditions for the use of this method are:

- beams should only support timber floors in accordance with this chapter
- both beams have been chosen from Table 3
- beams do not differ in depth by more than 40mm.

Connections between steel sections should be designed by an engineer in accordance with Technical Requirement R5, where the above conditions are not met.

6.5.7 Examples

- 1 Using information about the supported wall and Table 1:
 - load per metre run = 4.2kN/m.
- 2 Using the load per metre run, the span of the beam and Table 2:
 - suitable section size = 178 x 102 x 19 UB.

152 x 152 x 23 UC is not suitable as it is too wide for the inner padstone/wall.
- 3 Using information about the wall supporting the beam (100mm thick), the walls supported by the beam (medium density block) and Table 6:

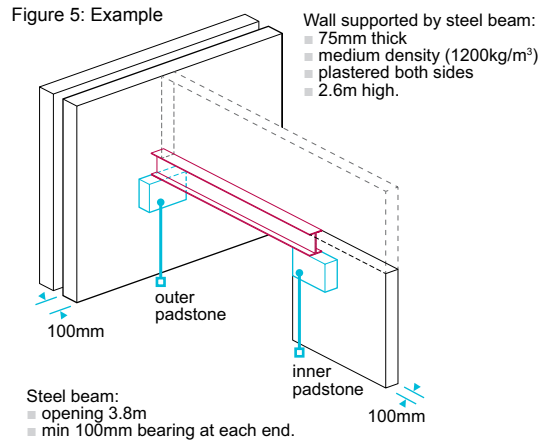

Results from example calculation:

Minimum padstone size	155mm long 150mm deep
Outer padstone (beam at right angles to wall)	
Minimum length	155mm long ⁽¹⁾
Minimum depth	150mm
Thickness	100mm, to match blockwork ⁽²⁾
Inner padstone (beam in line with the wall)	
Minimum length	200mm (see note 2 to Table 6)
Minimum depth	150mm
Thickness	100mm, to match blockwork

Notes

1. This is greater than the flange dimension of the steel section obtained in 2 above — 102mm — therefore a padstone is required to distribute the load.
2. The actual length and depth of a padstone could be greater to suit masonry coursing.



Chapter 6.6



Staircases

This chapter gives guidance on meeting the Technical Requirements for staircases.

6.6.1	Compliance	02
6.6.2	Provision of information	02
6.6.3	Fire precautions	02
6.6.4	Lighting	03
6.6.5	Glazing	03
6.6.6	Structural design	03
6.6.7	Headroom and width	03
6.6.8	Design of steps	04
6.6.9	Landings	05
6.6.10	Guarding	05
6.6.11	Handrails	06
6.6.12	Staircases made from timber and wood-based products	08
6.6.13	Concrete staircases	09
6.6.14	Steel staircases	09
6.6.15	Proprietary staircase units	09
6.6.16	Protection	09
6.6.17	Further information	10



Figure reference table

Figure Reference Table 6.6

Fig No	Title/Description	Clause	Page
Figure 1	Minimum headroom	6.6.7	4
Figure 2	Pitch line	6.6.8.1	4
Figure 3	Equal risers	6.6.8.2	4
Figure 4	Open risers	6.6.8.2	4
Figure 5	Measuring tapered treads (staircase less than 1m wide only)	6.6.8.3	5
Figure 6	Landings next to doors (bottom of stairs only)	6.6.9	5
Figure 7	Protective guarding	6.6.10	6
Figure 8	Minimum clearance gap	6.6.11	6
Figure 9	Handrail provision	6.6.11	7
Figure 10	Handrail provision	6.6.11	7
Figure 11	Handrail provision	6.6.11	7
Figure 12	Handrail provision	6.6.11	7
Figure 13	Handrail provision	6.6.11	7
Figure 14	Handrail provision	6.6.11	7
Figure 15	Handrail provision	6.6.11	8
Figure 16	Staircase fixing	6.6.12	8
Figure 17	Timber staircase protection	6.6.16	9

Definitions for this chapter

Balustrading	The collective name for the complete assembly of handrails, baserails, newels, spindles and caps.
Common (communal) stair	A staircase serving more than one property.
Continuous handrail	Using lengths of connected handrail, the handrail flows over the tops of newel turnings, creating a continuous run of handrail.
Going	The depth from the front to the back of the tread, less any overlap with the next tread above.
Guarding	A barrier that denies pedestrians or vehicle access to another area, eg the floor below.
General access stair	A stair intended for all users of a building on a day-to-day basis, as a normal route between levels.
Newel post	A post at the head or foot of a flight of stairs, supporting a handrail.
Nosing	The edge of the tread projecting beyond the face of the riser.
Pitch	The angle between the pitch line and the horizontal.
Pitch line	A notional line connecting the nosings of all treads in a flight of stairs.
Private stair	A staircase wholly within one dwelling.
Rise	The vertical distance between the floors or landings connected by a flight. The individual rise is the vertical measurement from the top of a tread to the top of the next tread.
Riser	The board that forms the face of the step.
Spindle	A vertical member, plain or decorative, that acts as the infill between the handrail and baserail.
Staircase	The entire structure relating to a stair, comprising steps, treads, risers, strings, balustrading, landings, etc.
Stairway	The space/void provided for the stairs.
Step	The tread and riser combined.
Tread	The top or horizontal surface of a step.
Utility stair	A staircase used for escape, access for maintenance or purposes other than moving between levels on a day-to-day basis.
Winders	Radiating steps, narrower at one end, that are used to change the direction of stairs through 90° or 180°.

6.6.1 Compliance

Also see: Chapter 2.1

Staircases shall comply with the Technical Requirements.

Staircases which comply with the guidance in this chapter and relevant Building Regulations will generally be acceptable. Further guidance can be found in BS 5395-1.

6.6.2 Provision of information

Designs and specifications shall be produced in a clearly understandable format, include all relevant information and be distributed to appropriate personnel.

Staircase design and specification information should be issued to site supervisors, relevant specialist subcontractors and suppliers, and include the following information:

- layout of stairs, landings and position of handrails
- dimensions covering width, rise and going, handrail height, etc
- the type, size and length of fixings, their location and number, and the type of wall and joists/trimmers the stair is being secured to
- landing design and structural support arrangement.

6.6.3 Fire precautions

Where required for fire escape, staircases shall be suitably designed.

Staircases should be designed to meet relevant Building Regulations, taking into account the fire resistance of components and smoke ventilation. Further guidance can be found in BS 9991 and BS 9999.

6.6.4 Lighting

Also see: Part 8

Staircases shall be adequately lit.

Artificial light sources should be provided to all staircases and landings within homes and common areas, and be controlled by two-way switching. Alternatively, automatic light-sensitive controls may be used.

6.6.5 Glazing

Also see: GGF Safety and Security Glazing Good Practice Guide

Glazing near staircases (where contact could be made by someone using the stairs) shall be suitable for its location.

Where staircases are located close to glazing, any glass below the minimum guarding height, or within a zone where a user may make impact, the glass should either not break or be designed to break safely. The glazing should be at least one of the following:

- protected by a balustrade or railing (balustrade spacing should be a maximum of 75mm)
- toughened or laminated glass
- constructed using glass blocks.

6.6.6 Structural design

Staircases shall be properly supported and transmit loads to the supporting structure without undue movement, deflection or deformation.

Staircases should be designed and comply with relevant Building Regulations and Table 1.

Table 1: Standards for stair construction

Type of staircase	Relevant standard	Additional guidance
Timber staircases (straight flights, ¼ or ½ landings)	BS 585: Part 1 or 2	The stair and landing support method and fixings should be specified See also Chapter 3.3 Timber preservation (natural solid timber)
Reinforced concrete staircases	BS EN 1992-1-1	Should be designed by an engineer in accordance with Technical Requirement R5 See also Chapter 3.1 Concrete and its reinforcement
Steel staircases	BS EN 1993-1-1	See also Chapter 6.5 Steelwork
Proprietary staircases		Proprietary staircases should meet Technical Requirement R3

Timber stud walls may require additional noggings to provide appropriate fixing locations, and block walls should be sufficiently robust to support the required loads and to receive appropriate fixings. It should be noted that stairs generally are unable to be secured to metal stud walls.

Differential movement

When considering differential movement in relation to setting out, levels and finishes, allowances should be made for:

- casting/fabrication tolerances
- deflection under load
- foundation settlement
- creep and thermal movement
- storey height.

6.6.7 Headroom and width

Staircase openings shall be adequately sized.

Stairs should have a minimum of 2m clear head room (H) over the entire length and width of the stairway and landing, as measured vertically from the pitch line or landing.

Staircases should have the minimum width as required by the relevant Building Regulations.

The overall floor opening should be checked off plan and on site prior to the stairs being installed:

- for size to accept the stairs, with sufficient clearance to enable installation
- to allow for sufficient headroom.

Where staircases form part of a means of escape, reference should be made to the relevant Building Regulations.

Figure 1: Minimum headroom



6.6.8 Design of steps

Also see: BS 5395

Steps shall be constructed to allow the safe use of the staircase. Issues to be taken into account include:

- 1) pitch
- 2) steps
- 3) tapered treads and winders.

6.6.8.1 Pitch

The maximum angle of pitch of a stairway should not exceed:

- 42° for private stairs.

The dimensions for maximum rise and minimum going should meet relevant Building Regulations.

Private stairs should have a maximum rise of 220mm and minimum going of 220mm (225mm minimum going in Scotland).

Stairs should be dimensioned so that the rise (R) and the going (G) is between 550mm and 700mm when using the equation:
 $2R + G$.

Staircases should be accurately located and fixed with the string at the correct angle to ensure all treads are level.

6.6.8.2 Steps

In each flight:

- treads should be level
- the rise and going of steps should be equal
- account should be taken of the thicknesses of screeds (floor finishes that reduce the bottom rise by a maximum of 12mm are acceptable)
- the treads should overlap by a minimum of 16mm (15mm in Scotland) where the riser is open
- open risers should not permit a 100mm sphere to pass through and are not permitted for common stairs.

Figure 3: Equal risers

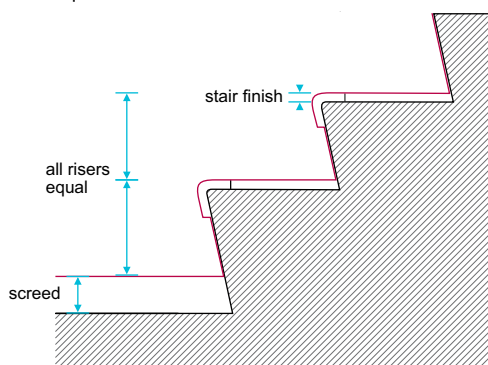

Figure 2: Pitch line

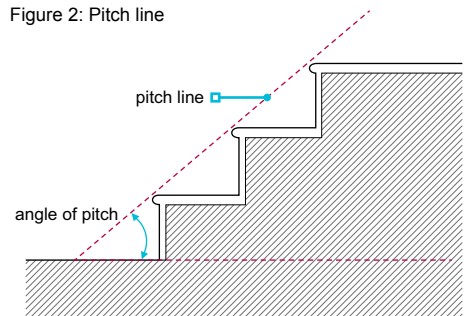
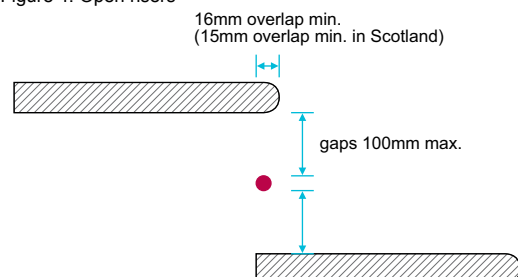

Figure 4: Open risers



Where stairs are open to the weather, designers should consider that grip may be affected by inclement weather, and one of the following should be specified:

- a non-slip finish
- a non-slip insert to each tread.

6.6.8.3 Tapered treads and winders

The rise of tapered treads should be consistent throughout the staircase. The going should be:

- uniform and no less than the going of the associated straight flight
- a minimum of 50mm at the narrowest point
- measured in accordance with the relevant Building Regulations.

Figure 5: Measuring tapered treads (staircase less than 1m wide only)

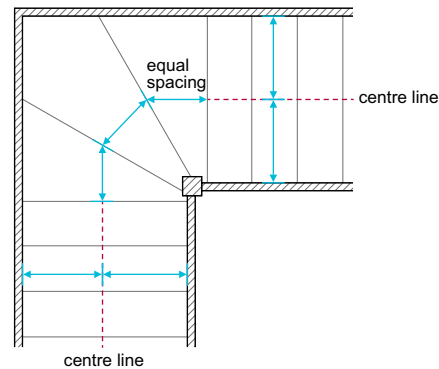

6.6.9 Landings

Landings shall allow safe use of the staircase.

Landings should be:

- constructed in accordance with the design
- properly supported and transmit loads to the supporting structure without undue movement, deflection or deformation
- framed to provide full support and solid fixings for the tops of flights, nosings, newels, apron linings, etc

Door swings should not obstruct landings. A door may open across the bottom landing of private stairs where the swing is a minimum of 400mm from the first tread.

Pivot windows should not obstruct the landing area or stair flight when they are opened.

Landings should typically be:

- provided at the top and bottom of every flight
- level and at least the same depth and width as the width of the stair.

Figure 6: Landings next to doors (bottom of stairs only)

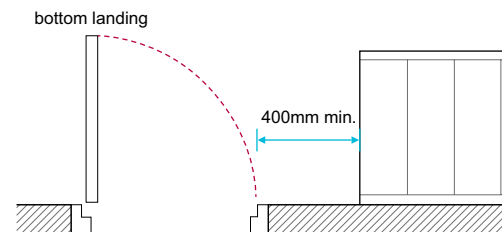

6.6.10 Guarding

Staircases shall have adequate guarding and be constructed to reduce the risk of being climbed or falling through.

Guarding:

- is required where the drop is more than 600mm at any point along the open sides of stairs and landings
- may be required where a stair abuts an opening window, to comply with relevant Building Regulations.

Guarding should be:

- provided along the full length of the flight, including landings
- capable of resisting forces, in accordance with Table 2 and BS 6180
- a solid wall or balustrading
- positioned at a height, in accordance with Table 3.

Table 2: Minimum horizontal imposed loads for parapets, barriers and balustrades for residential usages

Type of occupancy	Example use	Horizontal uniformly distributed line load (kN/m)	Uniformly distributed load applied to the infill (kN/m ²)	A point load applied to part of the infill (kN)
Domestic and residential activities	All areas within or serving exclusively one single family dwelling including stairs, landings, etc but excluding external balconies and edges of roofs	0.36	0.5	0.25
	Other residential ie, houses of multiple occupancy and balconies, including juliette balconies and edges of roofs in single family dwellings	0.74	1.0	0.5

Table 3: Guarding height

Type of stairs	Flights — minimum guarding height (mm)	Landings — minimum guarding height (mm)
Private stairs (England, Wales, Northern Ireland and the Isle of Man)	900	900
Private stairs (Scotland)	840–1,000	900
Common stairs	900	1,100

Balustrading should:

- be fixed securely
- not be climbed easily by children, eg have no horizontal foot holds which would enable climbing
- not permit a 100mm diameter sphere to pass through any opening (in Scotland and Northern Ireland, the space between a rise in a stair and the lowest edge of the protective barrier may be larger than 100mm, provided the lowest edge of the barrier is not more than 50mm above, and parallel to, the pitch line of the stair).

Where guardrails or balustrades are long, newel posts may not be sufficient to transfer the horizontal forces to the structure, and intermediate posts may be required. The method of fixing newels should be specified, eg through-bolted to joists or alternative supports to an engineered design.

Figure 7: Protective guarding

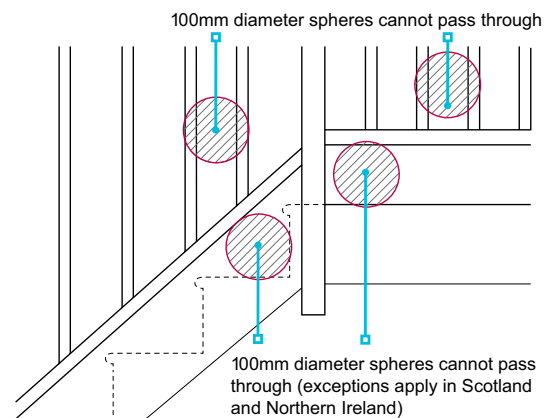

6.6.11 Handrails

Also see: BS 5395-1

Handrails shall be correctly located and fixed to provide a firm handhold.

A handrail is required for flights of stairs that rise over 600mm. The handrail (throughout the full length) should:

- be securely fixed and located in accordance with the design
- be a vertical distance of 900mm–1,000mm (or 840mm–1,000mm in Scotland) above the pitch line
- have a 25mm minimum clearance from any surface
- ensure a firm handhold
- have rounded ends or be returned to the wall to reduce the risk of clothing being caught
- be continuous and unobstructed
- have a smooth finish and be free from rough or sharp edges, including brackets or fixing heads.

Figure 8: Minimum clearance gap

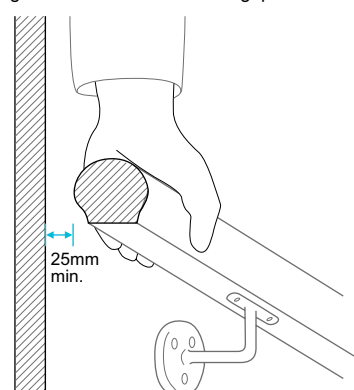

For tapered treads/winders, where handrails to the outside of the stairs are provided, they should provide a safe handhold for the full rise of any stairs with a total rise greater than 600mm.

In England, Wales and Scotland, where the staircase has between one and four tapered treads/winders, the newel post may be used to provide a safe handhold. In Northern Ireland, a handrail should be fitted to the outside of all tapered stairs.

Figure 9: Handrail provision

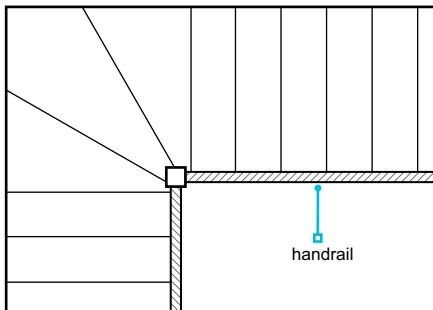

additional handrail not needed

Figure 10: Handrail provision

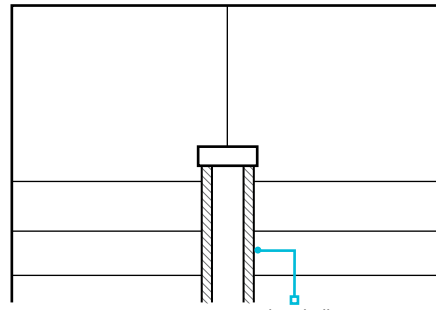

additional handrail not needed

Figure 11: Handrail provision

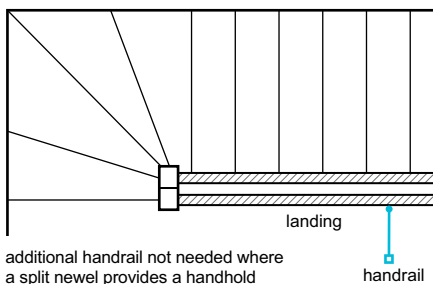

additional handrail not needed where a split newel provides a handhold

Figure 12: Handrail provision

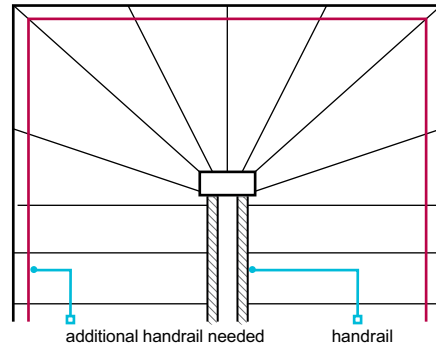

additional handrail needed

handrail

In England, Wales and Scotland, a handrail is not required on the outside of the stairs if the newels provide a safe handhold. There should be a minimum distance between newels of 100mm to provide a hand grip.

Figure 13: Handrail provision

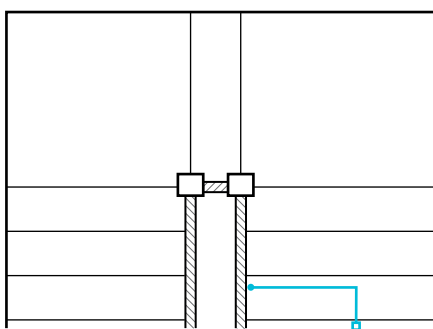

additional handrail not needed

handrail

Figure 14: Handrail provision

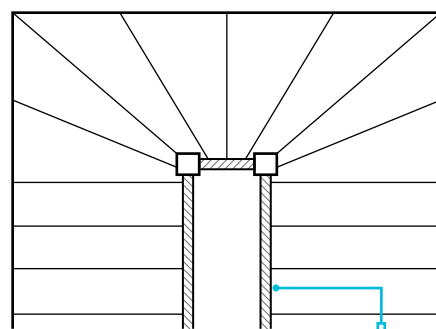

additional handrail not needed

handrail

Where a handrail is needed, it should be continuous for the whole rise to avoid the need to change hands. At corners, the handrails do not need to join if they extend into the corner and provision is made for an easy transfer of a handhold from one handrail to another.

Figure 15: Handrail provision

where a double newel is not full height but provides a single newel for handhold purposes, no additional handrail on the outside of the stairs is required; in Northern Ireland, a handrail should be fitted to the outside of all tapered stairs

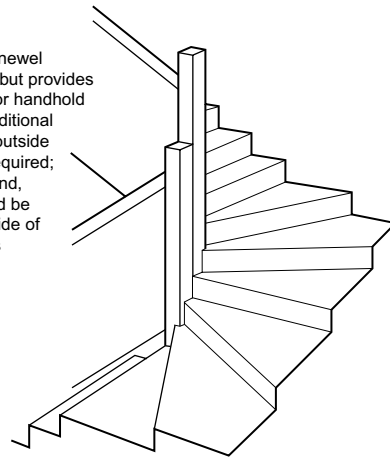

Also see: Chapter 3.3, British Woodworking Federation Stair Scheme Installation Guide Timber Stairs and BS 585 Parts 1 and 2

6.6.12 Staircases made from timber and wood-based products

Staircases made from timber products shall be suitable for their intended purpose and of suitable quality.

Timber staircases should be adequately fixed to the supporting structure.

Stair strings should be fixed to the wall in accordance with guidance supplied by the manufacturer or published in the British Woodworking Federation Stair Scheme Installation Guide Timber Stairs.

Where light gauge steel framing (LSF) is intended to be used to support staircases, the stud manufacturer should be consulted to ensure the framing can adequately support the staircase loads.

The wall string should be cut to sit over the floor joist to land evenly on the floor or landing.

The top nosing should be:

- level with the floor decking
- screwed into the joist.

Newel posts should be plumb, and all components, including strings, treads and risers, newel posts, balustrading and handrails, fixed securely. Particular attention should be given to fixing winders.

Strings should be glued to the newel posts and secured with dowels or screws.

Staircase fixing requirements should not impede any fire or acoustic requirements for the supporting structure.

Landings should be:

- constructed in accordance with the design
- properly supported and transmit loads to the supporting structure without undue movement, deflection or deformation

Timber external staircases, landings and any necessary support should be:

- preservative treated or have adequate natural durability in accordance with Chapter 3.3 Timber preservation (natural solid timber)

Figure 16: Staircase fixing

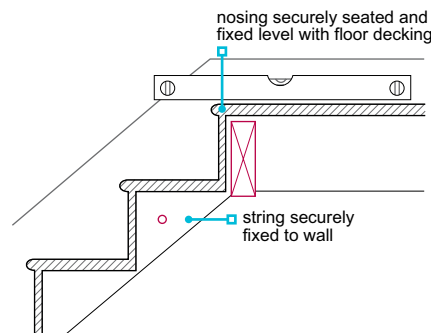

- framed to provide full support and solid fixings for the tops of flights, nosings, newels, apron linings, etc.

- constructed in accordance with guidance from the Timber Decking and Cladding Association Code of Practice: Raised timber deck structures on new homes.

Finished joinery should be free from splits, knocks and other damage which would impair its structural performance or finish.

Nails should be punched below the surface of the wood and stopped. Further guidance can be found in BS 1186-2.

6.6.13 Concrete staircases

Also see: Chapters 3.1 and 3.2

Staircases made from concrete shall be suitable for their intended purpose and be of suitable quality.

Concrete staircases should be designed and manufactured in accordance with BS EN 1992-1-1.

Precast construction

Precast staircases should comply with BS EN 14843, and account should be taken of:

- accurate location and levelling of units
- load paths.

In-situ construction

Guidance for in-situ concrete can be found in Chapter 3.1 Concrete and its reinforcement.

Shuttering for concrete elements or connections should be constructed to ensure a consistent rise and going.

Chairs or spacing blocks should be used to provide cover to reinforcement in accordance with Chapter 3.1 Concrete and its reinforcement.

Formwork should be struck in accordance with the design information.

Design information on the spacing of bolt fixings for balustrades or handrails should be followed.

Balustrading for concrete staircases should be:

- grouted into the preformed holes or pockets
- bolted to brackets cast into the concrete.

Care should be taken when using expanding fixings near the edges of concrete.

6.6.14 Steel staircases

Also see: Chapter 6.5

Staircases made from steel shall be suitable for their intended purpose and of suitable quality.

Steel staircases should be designed in accordance with BS EN 1993-1-1.

For steel staircases:

- the manufacturer's assembly and erection instructions should be available and followed
- protective coatings should be provided in accordance with Chapter 6.5 Steelwork.
- the supporting structure should be constructed within relevant tolerance limits set for the steel staircase

6.6.15 Proprietary staircase units

Proprietary staircases shall be suitable for their intended purpose and of suitable quality.

Proprietary staircases and associated components should comply with the Technical Requirements.

6.6.16 Protection

Stairs shall be free from damage and unsightly marks.

Staircases should be protected to prevent damage and unsightly marking during construction.

When storing staircases, they should be:

- stacked on bearers
- suitably protected from the weather.

Timber staircases should be fixed in place only when the building is weathertight.

Staircases, stair treads, nosings, balustrades and handrails may be protected with timber strips, plywood or building paper.

Timber staircases may be also affected by residual moisture contained within a concrete floor; an isolating DPC may be provided directly below the staircase to offer protection.

Figure 17: Timber staircase protection

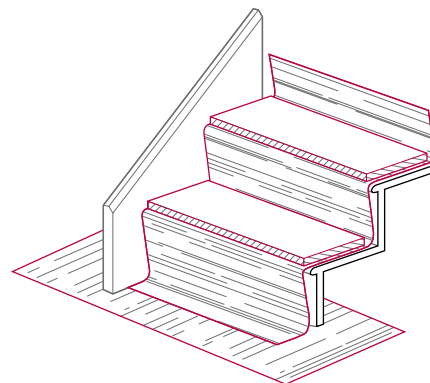

6.6.17 Further information

- *BS 5395-1 Stairs — Code of practice for the design of stairs with straight flights and winders*
- *BS 5395-2 Stairs, ladders and walkways — Code of practice for the design of helical and spiral stairs*
- *BS 585-1:1989 Wood stairs — Specification for stairs with closed risers for domestic use, including straight and winder flights and quarter or half landings*
- *BS 585-2:1985 Wood stairs — Specification for performance requirements for domestic stairs constructed of wood-based materials*

Chapter 6.7



Doors, windows and glazing

This chapter gives guidance on meeting the Technical Requirements for doors, windows and glazing, including where coupled door and window frame assemblies are contained within a single storey.

Coupled door and window frame assemblies (including spandrel panels) which are:

- one storey or more in height, or
- not contained between a structural floor and ceiling

should be designed in accordance with Chapter 6.9 Curtain walling and cladding.

This chapter does not provide guidance on compliance with Building Regulations. Work shall comply with all relevant Building Regulations covering:

- weathertightness
- thermal performance
- fire safety
- safety from impact
- ventilation
- security.

6.7.1	Compliance	02
6.7.2	Provision of information	02
6.7.3	In-service performance	03
6.7.4	Coupled door and window frame assemblies	05
6.7.5	Glazing	07
6.7.6	Security	09
6.7.7	Timber doors and windows	10
6.7.8	Non-timber doors and windows	11
6.7.9	Ironmongery	12
6.7.10	Material storage and protection	13
6.7.11	Installation	13
6.7.12	Completed work	15

Figure reference table**Figure Reference Table 6.7**

Fig No	Title/Description	Clause	Page
Figure 1	Water bar and weatherboard to external doors	6.7.3.1	3
Figure 2	Throating to window sill — cavity masonry wall	6.7.3.1	3
Figure 3	Throating to window sill — stone sill	6.7.3.1	4
Figure 4	Checked rebate	6.7.3.1	4
Figure 5	Treatment of cut ends	6.7.10.2	13

Definitions for this chapter

Air and vapour control layer (AVCL)	Continuous layer of material with a high resistance to water vapour to control the movement of air and water vapour.
Air barrier	A barrier to control air leakage into and out of the building envelope (for framed walls, this is usually in the form of a membrane).
Breather membrane	Continuous layer of material with a low resistance to water vapour to allow vapour movement but impermeable to water.
Building envelope	External wall or roof construction that separates the habitable parts of a building from the external environment.
Coupled door and window frame assemblies	A glazed wall formed by combining pre-assembled doors and/or windows (the window frames may be supported directly by brackets fixed to the primary structure or may be supported by horizontal and vertical framing members).
Doors	A complete door assembly, assembled on site or delivered as a complete assembly, consisting of the door frame, door leaf or leaves, essential hardware and any integral side panel or fanlight.
Fixings	Component that is used to secure separate parts of a window or door to each other, to secure an item of hardware to a window or door part, or to secure a completed window or door into the structure of a building.
Frames	Outer frame, mullion and transom components of doors and windows.
Glazing	Glass component of a door or window.
Glazing material	A material which provides a bedding for the glass and forms a joint between the glass and frame (including glazing compounds, sealants, putties, glazing strips and tapes, and gaskets).
Impregnated foam tapes	Impregnated foam weatherproofing strip: flexible, elastic, preformed material that constitutes a linear seal when compressed.
Insulating glass unit (IGU)	Assembly consisting of at least two panes of glass, separated by one or more spacers, hermetically sealed along the periphery, mechanically stable and durable.
Sealant	Wet applied compound, applied in an unformed state to a joint which seals it by adhering to appropriate surfaces within the joint.
Structural opening	Opening in an external wall or roof into which a window or door is to be installed.
System manufacturer	Company that designs, manufactures and supplies a system.
Thermal bridging	Weak points (or areas) in the building envelope that allows heat to pass through more easily.
Weathertightness	Performance in respect of air permeability, watertightness and resistance to windload.
Window	Building component or multiple components for closing an opening in a wall or roof that may admit light and/or provide ventilation.

6.7.1 Compliance

Also see: Chapter 2.1

Doors, windows and glazing shall comply with the Technical Requirements.

Doors, windows and glazing which comply with the guidance in this chapter will generally be acceptable.

6.7.2 Provision of information

Designs and specifications shall be produced in a clearly understandable format, include all relevant information and be distributed to appropriate personnel.

Design and specification information should be issued to site supervisors, relevant specialist subcontractors and suppliers.

6.7.3 In-service performance

Doors and windows shall be designed and specified to ensure adequate in-service performance. Issues to be taken into account include:

- 1) weathertightness
- 2) minimising thermal bridging
- 3) continuity of the air barrier
- 4) accommodating thermal movement
- 5) operation and strength.

6.7.3.1 Weathertightness

The following documents should show weathertightness performance classifications of doors and windows:

- CE/UKCA marking in accordance with BS EN 14351-1
- appropriate third-party product certification.

The performance classification levels should be appropriate for the site exposure conditions.

For doors and windows into low-rise housing, the suitability of weathertightness performance classification levels for the site exposure conditions may be determined according to the procedure in BS 6375-1.

Higher levels of performance should be specified for doors and windows into medium- and high-rise buildings as remedial works in the event of water leakage are likely to be more difficult. Windows in high-rise buildings may also be exposed to higher levels of wind-driven rain.

The satisfactory weathertightness performance of doors and windows also depends on appropriate detailing of interfaces with the surrounding building envelope. The interface between any window or door and its surround should be a robust detail that is easy to understand at the construction stage. It should be evident how it should be constructed and should be easy to inspect and/or test.

The head of frames should be set back from the edge of the lintel/cavity tray, and sills should project at least 25mm beyond the wall face.

Where doors and windows are incorporated into structural openings of timber framed walls, breather membranes should be used to provide a secondary water barrier to prevent entrapping water vapour and causing interstitial condensation within the wall.

Where accessible thresholds are required, the door should be protected from precipitation by a canopy, a drainage slot or channel adjacent to the sill provided and a platform with a slope of between 1:60 and 1:40 to ensure water run-off.

Checked rebates should be used in:

- Scotland
- Northern Ireland
- Isle of Man
- areas where the exposure to driving rain is very severe (severe/very severe exposure when building using timber frame).

Alternatively proprietary cavity closers which hold a satisfactory assessment by an appropriate independent technical approvals authority, accepted by NHBC, for the exposure zone may be acceptable.

Notes

1. Many manufacturers supply doors and windows which exceed the recommended classifications in BS 6375-1, commonly Class 9A (600Pa) for watertightness and Class 4 (600Pa) for air permeability. The use of doors and windows with higher levels of performance will reduce the risk of leakage.
2. Experience suggests that testing for watertightness at 25% of the design windload gives satisfactory performance, provided that the installation is carried out correctly.

Figure 1: Water bar and weatherboard to external doors

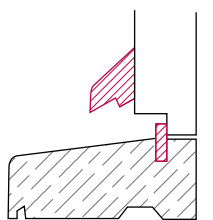

water bar and weatherboard provided for external doors

Figure 2: Throating to window sill — cavity masonry wall

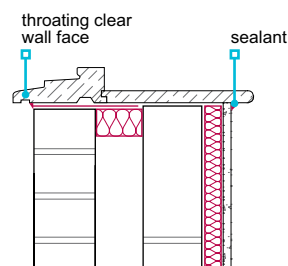

Figure 3: Throating to window sill — stone sill

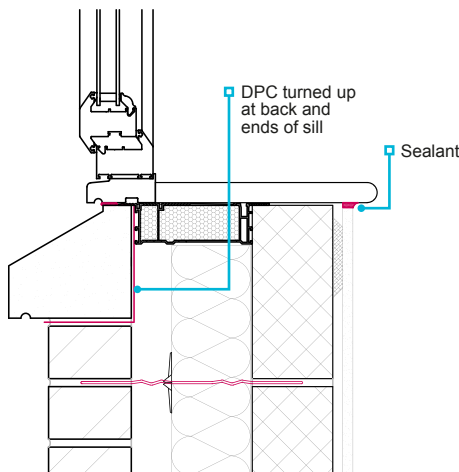
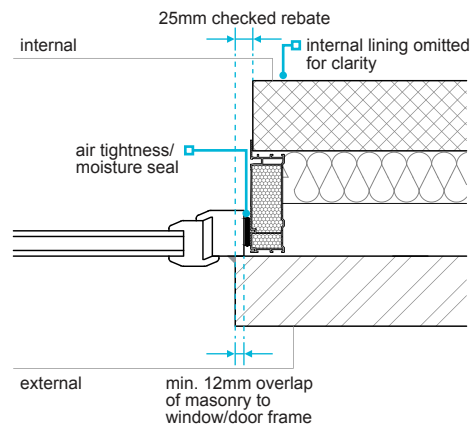

Figure 4: Checked rebate



6.7.3.2 Minimising thermal bridging

The interface between any door/window and its surround should be designed to minimise the effects of thermal bridging and risk of condensation.

In cavity masonry construction, insulated cavity closures should be built into the structural opening and cavity wall insulation tightly abutted to prevent gaps in the insulation.

Doors and windows should be positioned within the structural opening to maintain continuity of the insulation layer of the building envelope.

In cavity masonry walls, doors and windows should be positioned with an overlap between the inner face of the frame and the inner face of the outer leaf. The overlap should be between 30mm and 50mm for windows and 50mm for doors — so that the door or window is contiguous with the insulation layer of the external wall.

Note

1. For doors, reinforced cavity closures may need to be used at thresholds.

6.7.3.3 Continuity of the air barrier

To ensure continuity of the air barrier, door and window frames should connect to the primary air barrier and be appropriately sealed. For doors and windows incorporated into the structural openings of framed walls, the air barrier is likely to be formed by the air and vapour control layer. The air and vapour control layer should be taped and sealed in accordance with the manufacturer's instructions.

6.7.3.4 Accommodating movement

Expansion and contraction of frames is to be expected due to temperature fluctuations. To prevent frames from distorting, a gap around the perimeter of the frame and the structural opening should be provided.

The gap size depends on the frame material and the structural opening size and should be selected in accordance with Table 1.

Table 1: Recommended gaps between the frame and structural opening

Material	Structural opening size and recommend gap size		
	Up to 1.5m	From 1.5m to 3.0m	From 3.0m to 4.5m
PVC-U — white	10	10	15
PVC-U — non-white	15	15	22
Timber	10	10	10
Steel	8	10	12
Aluminium	10	10	15

Dimensions in mm

The perimeter gap should be sealed with a suitable sealant which is able to resist water penetration and prevent air leakage whilst accommodating differential movement between the structural opening and the frame.

For doors and windows incorporated into the structural openings of timber frame walls, opening and closing gaps should be provided around the frames in accordance with Chapter 6.2 External timber framed walls to allow for the thermal movement of frames and structural movement of the timber frame.

Silicone sealants should be applied to a closed cell polyethylene foam backing strip to control the depth of the joint, force the sealant against the sides of the joint during application and aid tooling of the sealant. The depth of sealant should be at least 5mm.

For checked rebates, the sealant should form a fillet with an overlap of 6mm to the frame and 10mm to the brick outer leaf.

When impregnated foam tapes are used for perimeter sealing, over sealing with a wet sealant is not usually required. Manufacturers' instructions and product certifications should be followed.

Further guidance on sealants is provided in the following standards:

- BS 6093 Design of joints and jointing in building construction. Guide
- BS 6213 Selection of construction sealants. Guide
- BS EN ISO 11600 Building construction. Jointing products. Classification and requirements for sealants.

6.7.3.5 Operation and strength

Doors, windows and their fittings should be adequate to withstand operational loads. Characteristics and classes of performance should be in line with the relevant class of window or doorset as defined in Annex A of BS 6375-2.

6.7.4 Coupled door and window frame assemblies

Coupled door and window frame assemblies shall be designed and installed to provide adequate in-service performance. Issues to be considered include:

- | | |
|-------------------------|-------------------------------------|
| 1) system design | 4) movement accommodation |
| 2) weathertightness | 5) thermal performance |
| 3) structural integrity | 6) site testing for watertightness. |

6.7.4.1 System design

Coupled door and window frame assemblies should be supplied as a standard system comprising only of components designed and detailed by the system manufacturer.

6.7.4.2 Weathertightness

Jointing details should be designed on the principle of two lines of defence with flexible inner and outer seals. The cavity between the seals should be drained to remove any water that bypasses the outer seals.

Weathertightness of coupling joints may be adversely affected by deflections under windload. Weathertightness of coupling joints should be demonstrated by appropriate laboratory testing of an assembly.

Testing should be undertaken by a UKAS accredited test laboratory. During testing, there should be no leakage onto the internal face of the system at any time.

On completion of the test, there should be no standing water in locations intended to remain dry. Any remedial modifications to the system that are made to pass the test should be reported and incorporated into the installed system.

To avoid difficulty in interpreting the results, it is good practice to agree which materials and zones within the system may be allowed to get wet.

Alternative jointing details should not be used unless they have been proven by testing. The interface between the assembly and the surrounding building envelope should be a robust detail that is easy to understand at the construction stage. It should be evident how the coupling and interface details are to be constructed and should be easy to inspect and/or test.

6.7.4.3 Structural integrity

Coupled door and window frame assemblies should be designed as an engineered system to support their self-weight, resist and safely transfer imposed loads back to the supporting structure.

Windows tested and classified to BS EN 14351-1 are subjected to wind load tests; however, as the perimeter of the window is supported by the test box, the response of the perimeter frame to wind load will not have been fully assessed.

The perimeter frame of the window used in an assembly needs to be able to resist the wind load in bending or the joining component needs to provide support and contribute to the overall stiffness of the system in resisting deflection arising from wind pressure and other loadings, including accidental impact.

For window assemblies, it is recommended that the main structural members of the assembly satisfy class B for which the allowable deflection is span/200 under the design wind load in both positive and negative directions. This is the limit which applies for curtain wall mullions in BS EN 13830.

6.7.4.4 Movement accommodation

As window assemblies are larger than individual windows, the amount of movement to be accommodated is also likely to be greater. Coupling joints and interfaces with the surrounding construction should be designed to accommodate thermal expansion/contraction of the frames and movement of the structure, whilst remaining weathertight.

6.7.4.5 Thermal bridging

Coupling joints, brackets and fixings may create additional heat flow paths resulting in low surface temperatures, increasing the risk of surface condensation.

Coupling joints and interfaces with the supporting structure should be designed to minimise the effects of thermal bridging and risk of condensation, including the appropriate use of thermal breaks.

The thermal assessments of linear coupling joints and interfaces with the supporting structure should be checked to assess the risk of surface condensation.

The assessments should confirm that, under normal operating conditions, condensation does not form on the visible interior surfaces of any framing members or glazing.

6.7.4.6 Site testing for watertightness

To check the workmanship of the installation has not compromised the performance of the system in any way, on-site watertightness testing of coupling joints should be carried out by a UKAS accredited test laboratory using the Centre for Window and Cladding Technology (CWCT) hose test method for water penetration.

A minimum of 5% by length of all critical coupling joints should be tested. Where coupled assemblies of the same type are to be installed across a development, a minimum of two installations should be tested.

For phased developments, the minimum testing applies to each phase.

Testing should be carried out on the first installation on any development or phase before progressing with further installations.

On-site testing may be increased in areas of the UK that are expected to be subjected to severe weather exposure.

If on-site watertightness testing reveals problems with workmanship, these problems should be addressed, and additional testing carried out to confirm satisfactory watertightness performance is achieved before progressing further with the installation.

6.7.5 Glazing

The method of glazing shall ensure adequate in-service performance. Issues to be considered include:

- | | |
|-----------------------------|----------------------------------|
| 1) standards | 4) glazing systems |
| 2) performance requirements | 5) condition before installation |
| 3) insulating glass units | 6) site glazing. |

6.7.5.1 Standards

Glazing and materials should conform to relevant British Standards as shown in Table 2.

Table 2: Relevant British Standards for glazing

Standard/Specification Number	Standard/Specification Name
BS EN 1279-5	Glass in building. Insulating glass units — Product standard
BS EN 572-9	Glass in building. Basic soda lime silicate glass products — Evaluation of conformity/Product standard
BS EN 14449	Glass in building. Laminated glass and laminated safety glass. Evaluation of conformity/Product standard
BS EN 12150-2	Glass in building. Thermally toughened soda lime silicate safety glass — Evaluation of conformity/Product standard
BS EN 1096-4	Glass in building. Coated glass — Product standard

6.7.5.2 Performance requirements

Glazing should be selected to meet applicable design and performance requirements in accordance with BS 6262-1.

The type, thickness and size of glass should be selected to provide an appropriate degree of safety, considering the intended use.

Safety glass for use in critical locations (including glazed shower/bath screens) should be marked as follows:

- the manufacturer's trademark or name
- the standard number for the type of glass, eg BS EN 14449 laminated glass
- the impact performance classification, eg 1, 2, 3 to BS EN 12600.

The design loads acting upon the glazed area should be determined in accordance with BS EN 1991-1-1, BS EN 1991-1-3 and BS EN 1991-1-4. The type, thickness and size of glass should be specified to suit the design wind loads.

To improve thermal performance and minimise condensation formation around the perimeter zone of glass, glazed units with spacer bars of low thermal conductivity should be specified.

6.7.5.3 Insulating glass units

Insulating glass units should:

- be CE/UKCA marked in accordance with BS EN 1279
- hold appropriate third-party certification, eg BSI Kitemark
- be checked to ensure they comply with the design, including glass type, gas filling, edge seal type and dimensions
- have a dual seal or a single seal of hot melt butyl and desiccant in at least one long and one short section of the spacer bar.

6.7.5.4 Glazing systems

Drained and vented systems

Drained and vented systems should be used for site-fixed insulating glass units (IGUs) and where units greater than 1m² are used. These systems allow moisture that enters the glazing channel between the frame and the edge seal of the insulating glass unit to drain away and prevent long-term moisture contact with the edge seal.

To achieve the optimum service life of insulating glass units, the following basic principles should be adopted in the design of drained and vented systems:

- **Removal of moisture:** Frames should have adequate drainage and ventilation through holes, slots or channels for the rapid removal of any water that may enter the glazing rebate.
- **Clearance:** A minimum 5mm edge clearance should be provided between the glass edge and frame to prevent frame-to-glass contact, ensure drainage, and allow for differential thermal expansion of the insulating glass unit and frame. For very well-drained and ventilated frames, the clearance can be reduced for the side and top rebates, to a minimum of 3mm in the case of glass lengths up to 2m.
- **Edge cover:** A minimum edge cover of 12mm should be provided to keep the spacer below the sight line and to protect the edge seal from sunlight.
- **Rebates:** The rebate height should allow for tolerances in both the frame size and insulating glass unit size to ensure the minimum edge clearance and minimum edge cover requirements are met. The width of the rebate platform should provide the required front and back clearances, and ensure sufficient contact of the glazing beads onto the platform. The width of the rebate platform should be equal to the sum of the front and back clearances, the nominal thickness of the insulating glass unit, the width of the bead, and an allowance for the tolerances on insulating glass unit and bead thicknesses.
- **Beads:** Should have an installed height equal to the rebate height. Timber beads for timber frames should have a width in contact with the rebate platform greater than the height, to enable firm fixing of the bead to be achieved. The bottom bead should project slightly past the rebate edge. Screw fixings for timber beads should be located a minimum of 75mm from each corner and spaced at no more than 200mm centres. If pins are used, they should be twice the height of the beads and located a minimum of 50mm from each corner and spaced at no more than 150mm centres. Beads for metal and plastic frames should be fixed in accordance with the manufacturer's recommendations to securely retain the insulating glass unit and the glazing seals.
- **Compatibility:** Glazing material should be compatible with frame finishes and glazing unit seals in accordance with the manufacturer's recommendations. Linseed oil-based putty should not be used in the installation of laminated glass or insulating glass units.

Fully bedded systems

Fully bedded systems are acceptable for factory glazing only where the insulated unit is less than 1m², and should:

- comply with the relevant parts of BS 8000, BS 6262 and BRE Digest 453
- not have gaps around the perimeter of the insulating glass unit.

6.7.5.5 Condition before installation

When insulating glass units are stored prior to being installed, they should be:

- protected from direct sunlight to avoid thermal stress
- stored in dry conditions
- provided with adequate support to prevent distortion or bowing.

A visual inspection of glass and insulating glass units should be undertaken for signs of defects which could lead to premature failure. Signs of defects include:

- water accumulation between sheets
- edge damage or scratching.

6.7.5.6 Site glazing

Site glazing should be in accordance with the frame design and undertaken by installers who are appropriately trained and conversant with good glazing practice.

The following features should be checked before glazing:

- drainage and ventilation holes or slots are present, are of a suitable size and are free from obstructions such as fabrication swarf, etc
- ventilation and the free flow of water to holes and slots are not impeded by setting and location blocks, external bead retention lips or glazing materials
- as water can be present in the glazing rebate, screw fixing holes and frame joints are adequately sealed against water ingress
- a minimum 5mm edge clearance is provided around the perimeter of the insulating glass unit to prevent glass to frame contact, to ensure drainage and allow for differential thermal expansion
- gaskets or strip materials supplied cut to size are the correct length to ensure that there are no gaps at the corners.

Note

1. Further guidance on system design and glazing considerations for insulating glass units is provided by the Glass and Glazing Federation (GGF).

6.7.6 Security

Doors, door frames, windows and locks shall be designed and specified to improve their resistance to unauthorised entry. Issues to be considered include:

- 1) locking functionality of main entrance doors
- 2) locking functionality of secondary access doors
- 3) opening limitation device
- 4) view outside
- 5) glazing
- 6) framed wall constructions
- 7) door and frame connections
- 8) windows.

6.7.6.1 Locking functionality of main entrance doors

All homes

Entrance doors of individual homes should be fitted with securely fixed locks or a multipoint locking system, which:

- has at least 1,000 differs
- if burst open, would not pull out without breaking the door or its frame
- has a hardened steel bolt, or inserts, to prevent sawing
- has a latch and deadlocking facility.

Locking devices fitted to main entrance doors should permit emergency egress without the use of a key when the home is occupied.

Homes with an alternative means of escape via a door

- the door should be held closed on a latch
- deadlocking should be operated by a key externally and a handle or thumb turn internally (BS 8621 locks and PAS 8621 multipoint locks meet these requirements)
- enhanced security can be achieved by providing the facility to deadlock the internal thumb turn when leaving the home unoccupied (BS 10621 locks and PAS 10621 multipoint locks meet these requirements).

Homes opening directly to the outside without an alternative means of escape via a door

- the door should be held closed on a latch
- deadlocking should be operated by a key externally and a handle or thumb turn internally (BS 8621 locks and PAS 8621 multipoint locks meet these requirements).

Homes without an alternative means of escape opening onto a communal access

- the door should be held closed with a roller bolt or a latch operated by a handle internally and externally
- deadlocking should be operated by a key externally and a handle or thumb turn internally (BS 8621 locks and PAS 8621 multipoint locks meet these requirements).

6.7.6.2 Locking functionality of secondary access doors

Side hung doors should:

- be held closed on a latch operated by a handle both internally and externally
- have a deadlocking facility which can be operated by a key both internally and externally; alternatively, a thumb turn may be used internally (BS 3621 or BS 8621 (thumb turn) locks and PAS 3621 or PAS 8621 (thumb turn) multipoint locks meet these requirements)
- have bolts securely fixed at both the top and bottom of the door on the internal opening edge (where multipoint locking systems are used, bolts may be omitted).

Sliding doors should:

- be secured by way of a multipoint locking system with a minimum of three locking points, incorporating mushroom-headed bolts, hook bolts or shoot bolts that engage into the jamb or head, and sill of the door frame
- have an anti-lift device fitted so that doors cannot be lifted from their frame from the outside.

6.7.6.3 Opening limitation device

The main entrance door of individual homes should be fitted with a securely fixed opening limitation device.

In sheltered accommodation, opening limitation devices should not inhibit emergency access. Alternative methods for residents to identify and communicate with visitors without opening their door should be considered.

6.7.6.4 View outside

There should be a means of giving a wide-angle view of the area immediately outside the main entrance door of individual homes. Acceptable methods include:

- a through-door viewer
- clear glazing either to part of the door or a convenient window
- closed-circuit camera and displays (not connected to a TV).

6.7.6.5 Glazing

Any glazing which, if broken, would permit release of the internal handle or thumb turn by hand or arm entry should be laminated.

6.7.6.6 Framed wall constructions

Lightweight timber or steel framed walls next to doors fitted with locks operated internally with a handle or thumb turn should incorporate either timber sheathing (minimum 9mm thick) or expanded metal, 600mm wide and the full height of the door.

6.7.6.7 Door and frame connections

Connections between door and/or frame components which can be easily released from the outside should not be used. This includes accessible screw connections.

6.7.6.8 Windows

Opening lights on ground floor windows and others which are readily accessible from the outside may be fitted with lockable devices which cannot be released without a key.

6.7.7 Timber doors and windows

Also see: Chapters 3.3 and 9.5

Timber and wood-based materials shall be of suitable quality and be naturally durable or suitably treated.

Issues to be considered include:

- 1) quality assurance
- 2) classification and use
- 3) drying shrinkage
- 4) preparation and finish.

6.7.7.1 Quality assurance

Manufacturers of timber doors and windows should hold appropriate third-party certification to assure the fitness for purpose and quality of their products.

6.7.7.2 Classification and use

Timber windows should:

- conform to BS 644
- have a minimum 15mm rebate where double glazed units are to be installed.

Timber and wood-based materials should conform with the relevant requirements of BS EN 942 as shown in Table 3.

Table 3: Relevant requirements of BS EN 942

Component	Requirement
Glazing beads	European Redwood
Casements and sash windows	J classes
All other elements	Table 1 of BS EN 942

In England, Wales, Northern Ireland and the Isle of Man, planted stops are not permitted on frames to external doors.

External doors should be 42.5mm minimum (44mm nominal) in thickness.

6.7.7.3 Drying shrinkage

To minimise drying shrinkage, the moisture content of joinery, when fixed, should not exceed the value given in Table 4.

Table 4: Moisture content of joinery

Joinery items	Moisture content (%)
Windows and frames	17
Internal joinery:	
Intermittent heating	15
Continuous heating	12
Near to a heat source	9

Note

1. On delivery, the moisture content should be within +/-2% of the values specified.

6.7.7.4 Preparation and finish

The following elements of timber doors and windows should be of naturally durable timber or timber pre-treated against fungal decay:

- external door frames
- windows
- timber surrounds to metal windows
- external doors, other than flush doors.

Where material is:

- to be painted, it should be primed before fixing
- to be stained, it should have the first coat applied before delivery to site.

Compatibility between preservative treatment or primer, with glazing compounds, sealants, and finishes, should be checked with the relevant manufacturers.

Prefabricated items should conform with the relevant parts of BS 1186: Part 2, including:

- the fit and construction of joints and moving parts
- the construction of finger joints
- gluing and laminating
- surface finishes.

6.7.8 Non-timber doors and windows

Doors and windows of materials other than timber shall be of suitable quality. Issues to be considered include:

- 1) quality assurance
- 2) standards.

6.7.8.1 Quality assurance

Manufacturers of non-timber doors and windows should hold appropriate third-party certification to assure the fitness for purpose and quality of their products.

6.7.8.2 Standards

Non-timber doors and windows should conform to relevant standards as shown in Table 5.

Table 5: Relevant standards for non-timber doors and windows

Standard/Specification Number	Standard/Specification Name
BS 4873	Aluminium alloy windows and doorsets. Specification
BS 6510	Steel-framed windows and glazed doors. Specification
BS 7412	Specification for windows and doorsets made from unplasticized polyvinyl chloride (PVC-U) extruded hollow profiles
BS EN 12608-1	Unplasticized poly(vinyl chloride) (PVC-U) profiles for the fabrication of windows and doors. Classification, requirements, and test methods — Non-coated PVC-U profiles with light coloured surfaces
BS 7414	Specification for white PVC-U extruded hollow profiles with heat welded corner joints for plastics windows: materials type B
BS 8529	Composite doorsets. Domestic external doorsets. Specification

6.7.9 Ironmongery

Ironmongery shall be suitable for the intended use.

Ironmongery should be provided in accordance with the design. Materials used for critical functions should comply with the appropriate standards given in Table 6.

Table 6: Relevant British standards for ironmongery

Standard/Specification Number	Standard/Specification Name
BS EN 1935	Building hardware. Single-axis hinges. Requirements and test methods
BS 3621	Lock assemblies operated by key from both the inside and outside of the door
BS 8621	Lock assemblies operated by key from the outside of the door and by handle or thumb turn from the inside of the door
BS 10621	Lock assemblies in which the operating mode can be switched between the normal BS 8621 operating mode and a secure mode in which no egress is possible
BS EN 1906	Building hardware. Lever handles and knob furniture. Requirements and test methods
BS EN 12209	Building hardware. Locks and latches. Mechanically operated locks, latches and locking plates. Requirements and test methods
BS EN 1154	Building hardware. Controlled door closing devices. Requirements and test methods

Ironmongery for windows should be supplied as follows:

- hinges and fastenings of opening lights of windows should be of a type which prevents them from being opened from the outside when in the closed position
- where the windows are required by Building Regulations to have background ventilation, they may be fitted with trickle vents or some other means of providing ventilation which is controllable and located to avoid undue draughts. Windows with 'night vent' positions are not accepted as meeting this requirement.

Where doors to rooms containing a bath or WC have a securing device, it should be of a type capable of being opened from the outside in an emergency.

In sheltered accommodation, additional special provisions may be needed for all door locks, limiters and other fasteners, to enable wardens to gain access when necessary.

6.7.10 Material storage and protection

Joinery, door and window components shall be adequately protected against damp and decay. Issues to be considered include:

- | | |
|------------|--------------|
| 1) storage | 2) cut ends. |
|------------|--------------|

6.7.10.1 Storage

Where joinery is stored on site, precautions should include:

- avoiding wetting during unloading
- stacking external joinery on bearers off the ground and covering with waterproof material
- storing internal joinery in a weather-protected condition.

6.7.10.2 Cut ends

Where pre-treated joinery is cut or adjusted on site, the affected surfaces should be re-treated with appropriate preservative in accordance with the manufacturer's recommendations.

Figure 5: Treatment of cut ends

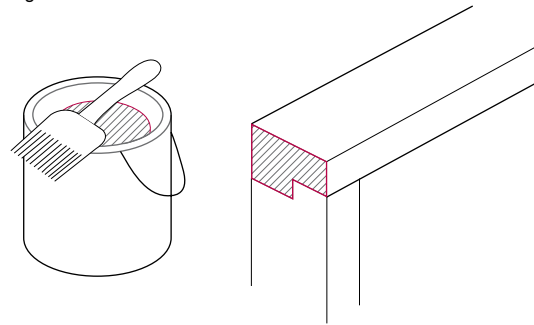

6.7.11 Installation

Doors and windows shall be correctly located and securely fixed. Issues to be considered include:

- | | |
|-------------------------------------|------------------|
| 1) construction tolerances | 5) door hinges |
| 2) workmanship and fixing | 6) window boards |
| 3) hanging doors and opening lights | 7) bay windows. |
| 4) general ironmongery | |

6.7.11.1 Construction tolerances

Construction tolerances for structural openings, doors and windows should be in accordance with Chapter 9.1 A consistent approach to finishes.

6.7.11.2 Workmanship and fixing

Doors and windows should be installed plumb and square within the structural opening in accordance with the manufacturer's instructions. The completed installation should be without twist, racking or distortion of any member so that they operate correctly.

Wherever practical, all four sides of the frame should be secured as follows:

- corner fixings should be between 150mm and 250mm from the external corner
- there should be a minimum of two fixings on each jamb and sill, with intermediate fixings at centres no greater than 600mm.
- fixings should be a minimum of 150mm from the centre line of a mullion or transom

Notes

1. The number and spacing of fixings at the head depend upon the frame width and frame material.
2. The manufacturer's instructions should be followed.

Internal door frames and linings should:

- match the thickness of the wall, partitions and finishes
- be securely fixed, to prevent curling.
- be blocked off walls wherever possible, to allow for full architraves

Timber trim should be:

- sufficiently wide to mask joints
- fixed to minimise movement and shrinkage.

Architraves should be:

- parallel to frames and linings
- accurately mitred, or scribed, to fit neatly and tightly
- fixed with an equal margin to each frame member
- fixed securely.

When fixing components:

- nails should be punched below the surface of the timber with holes stopped
- damage should be avoided.

6.7.11.3 Hanging doors and opening lights

Opening lights and door leaves should:

- hang square within the frame or lining
- fit neatly with minimum gaps.

Where a standard flush door is reduced in height, the bottom rail should be replaced where necessary.

6.7.11.4 General ironmongery

Hinges and other ironmongery should be:

- housed neatly and flush with the surface
- supplied with a full set of matching screws.

Locks should:

- turn easily
- not be fitted in mortises too tightly
- have keyholes which are properly aligned.

6.7.11.5 Door hinges

To reduce twisting, doors should be hung on hinges in accordance with Table 7.

Table 7: Summary of appropriate hinges for different door types

Type of door	Hinges
External	1½ pairs x 100mm
Internal door	1 pair x 75mm
Fire door	In accordance with the door manufacturer's recommendations
Airing or cylinder cupboard	1½ pairs x 75mm

6.7.11.6 Window boards

Window boards should:

- have a flat and level top surface
- be fixed close to the frame and adequately secured against twisting and other movement, particularly any back slope towards the frame
- be of a moisture-resistant grade where MDF is used.

6.7.11.7 Bay windows

Bay windows should be:

- adequately supported and secured to the structure to prevent sagging or twisting
- properly linked to DPCs at reveals.

6.7.12 Completed work**Completed work shall be free from damage.**

Work should be to an appropriate level of finish for other trades. Finishing trades should not be relied upon to correct untidy work.

Completed work should be protected as follows:

- internal doors should be kept covered with polyethylene or original wrapping
- door frames and linings should be protected with timber strips or plywood by a minimum of 1m above skirting level
- thresholds and windowsills should be covered
- scaffolding and walkways should be kept away from frames
- joinery should be protected from paint splashes and other damage
- temporary coverings should be removed after all other work has been completed and before handover.



Chapter 6.8



Fireplaces, chimneys and flues

This chapter gives guidance on meeting the Technical Requirements for fireplaces, chimneys and flues.

6.8.1	Compliance	03
6.8.2	Provision of information	03
6.8.3	Solid fuel – fireplaces and hearths	04
6.8.4	Solid fuel – combustion air	05
6.8.5	Solid fuel – flue pipes	05
6.8.6	Solid fuel – chimneys	05
6.8.7	Solid fuel – outlets and terminals	07
6.8.8	Gas – fireplaces and hearths	08
6.8.9	Gas – combustion air	09
6.8.10	Gas – flue pipes	09
6.8.11	Gas – chimneys	10
6.8.12	Gas – outlets and terminals	12
6.8.13	Liquid fuel – fireplaces and hearths	14
6.8.14	Liquid fuel – combustion air	14
6.8.15	Liquid fuel – flue pipes	14
6.8.16	Liquid fuel – chimneys	14
6.8.17	Liquid fuel – outlets and terminals	15
6.8.18	All – fireplaces and hearths	16
6.8.19	All – fireplace surrounds	17
6.8.20	All – flue pipes	17
6.8.21	All – flue liners	18
6.8.22	All – flues	19
6.8.23	All – chimneys	19
6.8.24	Masonry	22
6.8.25	Mortar	22
6.8.26	DPC	22
6.8.27	Flashings	22
6.8.28	Terminals	22
6.8.29	Flue testing	23
6.8.30	Further information	24



Figure reference table

Figure Reference Table 6.8

Fig No	Title/Description	Clause	Page
Figure 1	Solid fuel hearth clearances	6.8.3.1	4
Figure 2	Solid fuel hearth clearances to wall	6.8.3.2	4
Figure 3	Solid fuel appliance clearances to wall	6.8.3.2	4
Figure 4	Solid fuel flue-pipe clearances	6.8.5.2	5
Figure 5	Solid fuel outlet positions	6.8.7.1	7
Figure 6	Chimney capping	6.8.7.3	8
Figure 7	Hearth clearances for back boilers	6.8.8.2	9
Figure 8	Gas flue pipe support distances	6.8.10.1	9
Figure 9	Gas precast flue blocks to ridge terminal — cross-section	6.8.11.2	11
Figure 10	Gas precast flue blocks to ridge terminal transition	6.8.11.2	11
Figure 11	Precast flue block cavity wall insulation and vertical DPM	6.8.11.2	11
Figure 12	Precast flue blocks — false chimney breast arrangement with insulated cavity wall	6.8.11.2	11
Figure 13	Gas flue terminal positions	6.8.12	13
Figure 14	Drip collar for circular flues — cross-section	6.8.12	13
Figure 15	Drip collar plate detail for rectangular flues — cross-section	6.8.12	13
Figure 16	Hearth clearances	6.8.18	16
Figure 17	Fireplace recess — external cavity wall projection	6.8.18	16
Figure 18	Fireplace recess — external cavity wall with dimensions	6.8.18	16
Figure 19	Fireplace recess — internal wall with dimensions	6.8.18	16
Figure 20	Appliance recess with raft lintel (freestanding heater), front and side view	6.8.18	17
Figure 21	Lintelled opening for inset open fire (chimney throat insert), front and side view	6.8.18	17
Figure 22	Throat unit connection to lintel	6.8.20	17
Figure 23	Chimney joint to connecting flue pipe	6.8.20	17
Figure 24	Socketed flue pipe (socket up)	6.8.20	17
Figure 25	Offset chimney with flue liner suitable for solid fuel	6.8.21	18
Figure 26	Calculating maximum chimney height to width	6.8.23.1	19
Figure 27	Plan view of fireplace recess with frame	6.8.23.2	20
Figure 28	Plan view of chimney at upper floor level — 40mm airspace where non-combustible material <200mm thick	6.8.23.2	20
Figure 29	Timber chimney frame construction	6.8.23.2	20
Figure 30	External chimney breast with masonry inner leaf	6.8.23.2	20
Figure 31	Joist and masonry requirements for Scotland	6.8.23.2	20
Figure 32	Chimney cavity tray at pitch	6.8.23.2	20
Figure 33	Chimney cavity tray — cross-section (gather)	6.8.23.2	21
Figure 34	Prefabricated chimney throating	6.8.23.2	21
Figure 35	Chimney flashing and DPC tray (chimney on outside wall)	6.8.23.3	21
Figure 36	Chimney flashing and DPC tray — stack at ridge	6.8.23.3	21
Figure 37	Combined with DPC tray and flashing	6.8.23.3	21
Figure 38	Purpose made chimney capping (cross section)	6.8.28	23
Figure 39	Chimney details with brick capping	6.8.28	23

Definitions for this chapter

For the purposes of this chapter, the following definitions apply:

Balanced-flue chimney	Chimney comprising separate ducts for air supply and flue gas in concentric or parallel arrangement where the inlet of the air supply duct is adjacent to the outlet of the flue and the inlet and outlet being so positioned that wind effects are substantially balanced.
Builders opening	Enclosure constructed by builders to accommodate fireplace components.
Chimney	Structure consisting of a wall or walls enclosing a flue or flues conveying the products of combustion into the outside atmosphere.
Connecting flue pipe	Component or components connecting the combustion appliance outlet and the chimney.
Draught control	Device with a flap in a flue opening to allow entry of secondary air into the flue to regulate the draught.
Fireplace surround	Purpose-designed setting for a fire, fitted against a wall and usually incorporating a hearth.
Fireplace recess	Recess formed by the inclusion of fireplace components in the builders opening.
Flashings	Prefabricated components or site fabricated materials used for weatherproofing the penetration of the roof by the chimney.
Flue	Passage for conveying the products of combustion to the outside atmosphere.
Flue block	Factory-made single or multi-wall chimney component with one or more flues.
Flue liner	Rigid or flexible inner wall of a chimney consisting of components the inner surface of which is in contact with products of combustion.
Hearth	Slab of fire-resisting material to prevent overheating of the surface beneath the appliance.
Multi-wall chimney	Chimney consisting of a flue liner and at least one additional wall.
Open-flued chimney	Chimney that evacuates the products of combustion to the outside air, the combustion air being drawn directly from the room or space containing the appliance.
Preformed chimneys	Chimneys manufactured offsite, situated above the roofline, forming part of the building envelope and exposed to the external environment. They may be designed to replicate the aesthetics of a traditionally-constructed chimney (eg masonry). Chimneys of this type may or may not contain working flues.
Products of combustion	Products resulting from the combustion of fuel.
Single wall chimney	Chimney with only one wall.
Terminal	Component installed at the outlet of a chimney or a flue liner.
Terminal guard	Device fitted over a terminal and/or air inlet in order to protect persons from contact with, prevent interference with, and prevent damage to the terminal, and also to prevent flue blockage.
Liquid fuel	Mineral, vegetable or synthetic liquid or blends thereof, intended for combustion in boilers or cookers.

6.8.1 Compliance

Also see: Chapter 2.1

Fireplaces, chimneys and flues shall comply with the Technical Requirements, working fireplaces shall be designed to ensure efficient operation of the appliance, an adequate supply of combustion air and protection for the building fabric. Preformed chimneys shall comply with R3 and hold a satisfactory assessment by an appropriate independent technical approvals authority acceptable to NHBC.

Fireplaces, chimneys and flues which comply with the guidance in this chapter will generally be acceptable.

Installations should be provided with an adequate supply of combustion air:

- as stipulated by statutory requirements and Building Regulations
- to ensure satisfactory combustion of fuel and the efficient working of flues and chimneys.

Where a fixed combustion appliance is provided, appropriate provisions shall be made to detect and give warning to the release of carbon monoxide.

Where a chimney or flue is provided:

- it should be continuous from the hearth or appliance to the outside air
- a notice plate containing safety information about any hearths and flues should be securely fixed in an unobtrusive but obvious position within the home.

The design of homes which incorporate chimneys and flues should ensure that all details of the associated elements are considered and appropriate provisions made. This should include the following:

- fire risk and separation
- hearths and the constructions adjacent to hearths and flues
- chimneys and flues, including projections through the building
- terminals and outlets
- limitations on the appliance or open fire which can be installed, and fuel which can be used.

Good workmanship and effective supervision during construction are essential to ensure that fireplaces, chimneys and flues function correctly in use.

Fireplaces, chimneys and flues should be designed and installed to minimise the risk of the building catching fire. The design of timber frame construction should ensure that combustible material is:

- suitably separated from heat sources, or
- shielded, where permitted.

6.8.2 Provision of information

Designs and specifications shall be produced in a clearly understandable format, include all relevant information and be distributed to the appropriate personnel.

Clear and fully detailed drawings should be available on site to enable work to be carried out in accordance with the design. Design and specification information should be issued to site supervisors, relevant specialist subcontractors and suppliers, and include the following information:

- position and size of hearths, fireplaces, chimneys and flues
- position and proximity of combustible materials
- position and details of flue terminals or outlets
- position of DPCs and flashings
- construction details of fireplace openings and chimney connections
- details of materials to be used
- limitations of the type of appliance or open fire that can be installed and fuel that can be used
- details of the tests required on chimneys and flues, including who is responsible for carrying them out.

6.8.3 Solid fuel – fireplaces and hearths

Fireplaces and hearths shall safely accommodate the fire or appliance for which they are designed. Issues to be taken into account include:

- 1) provision of hearths and recesses
- 2) separation of hearths from walls.

Where appliances are not provided, it is important to construct fireplaces and hearths to suit the appliance most likely to be fitted.

6.8.3.1 Provision of hearths and recesses

Constructional hearths should be:

- provided for open fires or closed combustion appliances in accordance with Building Regulations and the manufacturer's recommendations
- a minimum of 840mm in any direction for freestanding appliances.

The adjacent figure shows the minimum dimensions from the appliance to the edge of the hearth.

Figure 1: Solid fuel hearth clearances

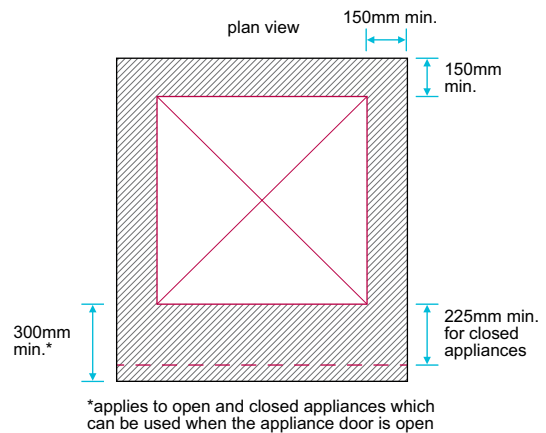

Recesses for open fires or closed combustion appliances:

- should be provided to comply with Building Regulations and the manufacturer's recommendations
- should be lined with a fire back or fire bricks
- where the opening is less than 500mm x 550mm, should have a 200mm diameter flue (or rectangular/square section flue of an equivalent area)
- where the opening is larger than 500mm x 550mm, should have a flue equivalent to 15% of the recess opening.

6.8.3.2 Separation of hearths from walls

Walls near appliances and their hearths should be:

- located to minimise the risk of fire
- non-combustible, or the appliance should not be positioned closer to the wall than as shown in the following figure.

Figure 2: Solid fuel hearth clearances to wall

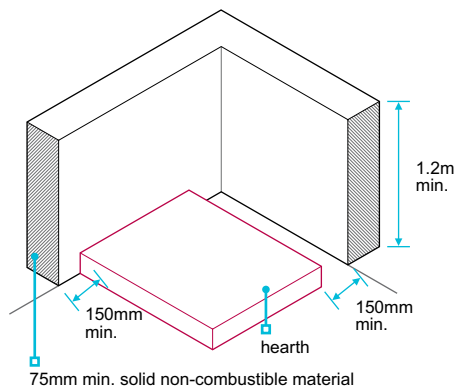
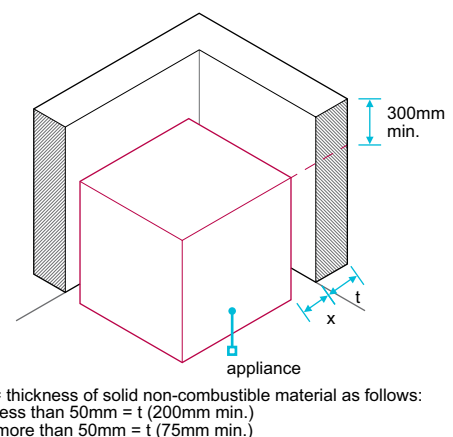

Figure 3: Solid fuel appliance clearances to wall



6.8.4 Solid fuel – combustion air

Installations shall be provided with an adequate supply of combustion air.

Solid fuel appliances should have an air supply from external air, either directly or indirectly, to comply with statutory requirements and the manufacturer's recommendations. Full details of ventilation requirements for all types of appliances are contained in relevant Building Regulations.

6.8.5 Solid fuel – flue pipes

Flue pipes shall be correctly designed to connect an appliance to a flue safely. Issues to be taken into account include:

- 1) size, direction and jointing
- 2) separation from combustible materials.

6.8.5.1 Size, direction and jointing

Flue pipes should have a cross-section which is equal to the outlet of the appliance they serve and should not be inclined more than 45° from vertical. A horizontal section no longer than 150mm may be used to connect a back outlet appliance to a flue.

Socket joints should be fitted socket up.

6.8.5.2 Separation from combustible materials

Flue pipes should be separated from combustible materials in accordance with Building Regulations, and:

- by a minimum 200mm of non-combustible material
- by an air space which is a minimum of 4xD, or
- be shielded by a non-combustible shield at least 4xD in width, and extended at least 1.5xD either side of the flue pipe; the shield should be at least 12mm from the combustible material, and the flue pipe at least 1.5xD from the combustible material.

(D = external diameter of the flue pipe)

Figure 4: Solid fuel flue-pipe clearances

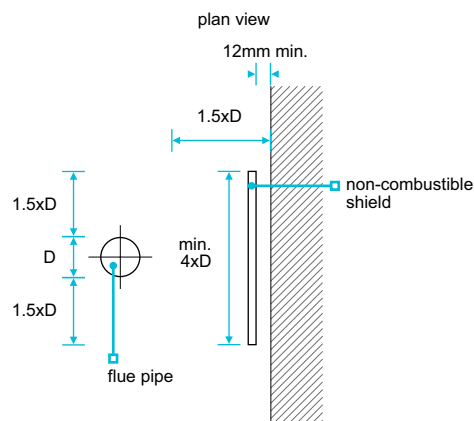

protecting combustible material from uninsulated flue pipes

6.8.6 Solid fuel – chimneys

Chimneys shall incorporate flues capable of safely conducting products of combustion to the external air. The structure shall be capable of supporting the flue lining and shall provide adequate protection to the adjacent structure. Issues to be taken into account include:

- 1) separation from adjacent spaces and materials
- 2) flue liners
- 3) resistance to frost attack
- 4) resistance to weather.

Flues for solid fuel appliances should:

- not serve more than one appliance
- be of a sufficient cross-section to remove all combustion gases from the open fire or appliance they serve
- where possible, be vertical (where this cannot be achieved, there should not be more than two bends; bends should not be more than 45° from vertical)
- be a minimum of 4.5m high (measured above the fireplace opening).

Where a chimney is not directly over an appliance or opening, an accessible soot box should be formed.

Factory-made insulated chimneys should:

- be designed in accordance with BS EN 1856 and BS EN 1859
- have a minimum operating life of 30 years
- be installed in accordance with BS EN 15287 or be assessed in accordance with Technical Requirement R3.

6.8.6.1 Separation from adjacent spaces and materials

Combustible materials close to any brickwork or blockwork chimney (not applicable to floorboards, skirting, dado or picture rails, mantelshelves or architraves) should be:

- a minimum of 200mm from the inside surface of the flue, or
- in all areas except Scotland, 40mm from the face of the chimney.

Where the home is of timber frame construction, full details of the separation proposal should be included in the design.

Materials used for chimneys should be capable of resisting fluctuating temperatures up to 1,100°C.

Flues formed within masonry walls. The walls should be:

- a minimum of 100mm thick, or
- a minimum of 200mm thick where separating the flue from another compartment of the same building, another building or another home.

Where there is more than one flue in a chimney, the flues should be separated by a minimum of 100mm of masonry.

6.8.6.2 Flue liners

Flue liners should:

- have rebated or socketed joints installed with the socket or internal rebate facing uppermost
- be installed in accordance with the manufacturer's recommendations
- be non-combustible
- be properly jointed at their junctions with the starter block, or lintel, and the outlet terminal
- be reasonably smooth on the inside
- be correctly jointed with mortar (the space between the liners and the brickwork should be filled with weak insulating concrete unless the manufacturer recommends an alternative)
- have any changes in direction formed using purpose-made bends (cut pipes are not acceptable).

6.8.6.3 Resistance to frost attack

Where clay brick chimneys are above roof level and are not protected by a capping with an adequate overhang and drip (see Clause 6.8.7.3), the chimney should be constructed using F2,S1 or F2,S2 bricks to BS EN 771. They should be bedded in mortar, either:

- 1:½:4 to 4½, cement:lime:sand, or
- 1:3 or 4, cement:sand with plasticiser.

Where external chimneys built with clay bricks of F2,S1 designation are rendered, sulfate-resistant cement should be used.

In Scotland, external facing brickwork should be constructed using frost-resistant bricks.

6.8.6.4 Resistance to weather

In areas of severe or very severe exposure, cavities should be continuous up to roof level. This applies to:

- cavities below roof level where the stack forms part of an external cavity wall
- the complete chimney structure, including the fireplace recess.

In areas of severe or very severe exposure, and where the chimney breast is gathered in, the lower projecting masonry should be protected against damp penetration with a suitable capping and cavity trays (see Clause 6.8.28.2).

Above the roof:

- chimney DPCs should link with flashings; where the roof is steeply pitched (where the difference in level between the lower and higher intersection of the chimney with the roof will be more than 450mm), two Damp Proof Course (DPC) should be used at suitable levels
- plastic DPCs are not suitable
- face brickwork should not have recessed joints
- where lead trays are in contact with mortar, they should be protected with a thick coat of bitumen or bitumen paint
- where chimneys are to be rendered, render should be in accordance with Chapter 6.11 Render.

6.8.7 Solid fuel – outlets and terminals

Outlets and terminals shall be adequately separated from combustible material and other parts of the home, enable the satisfactory discharge of flue gases and prevent the ingress of damp. Issues to be taken into account include:

- 1) outlet position
- 2) terminals
- 3) chimney cappings.

6.8.7.1 Outlet position

The flue will generally function more effectively where the outlet is in a low pressure zone, taking account of prevailing winds.

A low pressure zone generally occurs:

- on the lee side and at the ridge of a pitched roof
- close to the windward side of a flat roof.

Where the efficiency of the flue may be affected by adjacent trees or buildings in the low pressure zone, the design should account for their effects.

Where down draughts occur, eg on hillsides or near tall trees and buildings, the height of the flue outlet may have to be increased or a fan-assisted flue installed.

Figure 5: Solid fuel outlet positions

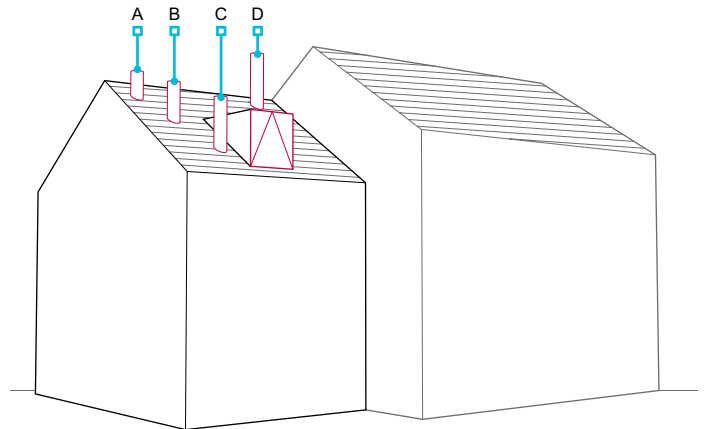

Table 1: Positions of outlets for solid fuel appliances⁽⁴⁾

	Point where flue passes through weather surface ^(1 & 2)	Minimum clearance from the flue outlet
A	Up to 600mm from ridge	Over 600mm above the ridge
B	Elsewhere on a roof (whether pitched or flat)	A minimum of 2.3m horizontally from the nearest point on the weather surface and: <ul style="list-style-type: none"> • a minimum of 1m above the highest point of intersection of the chimney and the weather surface, or • as high as the ridge.
C	Below (on a pitched roof) or within 2.3m horizontally from an openable rooflight, dormer window or other opening ⁽³⁾	A minimum of 1m from the top of the opening
D	Within 2.3m of the adjoining or adjacent building, whether or not beyond the boundary ⁽³⁾	A minimum of 600mm above the adjacent building

Notes

1. The weather surface is the building's external surface, such as its roof, tiles or external walls.
2. A flat roof has a pitch less than 10°.
3. The clearance given for A or B, as appropriate, will also apply.
4. Flue outlet positions for solid fuel appliances to easily ignited roof coverings need to comply with relevant Building Regulations.

6.8.7.2 Terminals

Terminals should be:

- purpose-made components
- sealed to the flue liner.
- built into the top of the masonry to a minimum of 125mm or 0.25x the length of the terminal, whichever is the greater

An acceptable terminal can be achieved where the top flue liner projects a minimum of 20mm above the chimney capping.

6.8.7.3 Chimney cappings

Chimney cappings should:

- be weathered, monolithic slabs
- be designed to protect the masonry below
- project a minimum of 50mm, and have a drip at least 30mm from the chimney face to shed water clear of the masonry.

Cappings may be designed as a cover slab supported on piers (to reduce rain penetration into the top of the flue). The height of the supporting piers should be sufficient to allow a free opening equivalent to a minimum of 2x the area of the flue outlet.

Brick chimneys which do not have this type of capping should be constructed using frost-resistant masonry.

Figure 6: Chimney capping

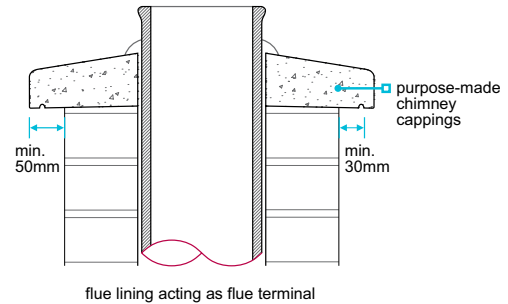

6.8.8 Gas – fireplaces and hearths

Fireplaces and hearths shall safely accommodate the fire or appliance for which they are designed. Issues to be taken into account include:

1) separation from combustible materials

2) provision of hearths and recesses.

Gas appliances should:

- be fitted by a Gas Safe Registered (GSR) installer holding the relevant competencies for the work in hand, and
- comply with the Gas Safety (Installation and Use) Regulations 1998.

6.8.8.1 Separation from combustible materials

Appliances should not be closer than 75mm to combustible material. This applies to:

- the back, sides and top of the appliance
- draught-diverters.

It does not apply:

- where a 25mm thick non-combustible shield is used, or
- to gas-fired appliances, installed in accordance with the manufacturer's written instructions, which clearly indicate such separation is not necessary.

6.8.8.2 Provision of hearths and recesses

Solid fuel effect appliances

Hearths and recesses for solid fuel effect appliances should be:

- in accordance with BS 5871
- in accordance with the requirements for solid fuel appliances (see Clause 6.8.3).

Where the appliance has been tested by an approved authority, in accordance with the manufacturer's instructions.

Back boilers

Hearths for back boilers should be constructed of solid non-combustible materials, a minimum of:

- 125mm thick, or
- 25mm thick and placed on non-combustible supports which are a minimum of 25mm high.

Other gas appliances

Hearths for other types of appliance should be constructed of non-combustible materials which:

- are a minimum of 12mm thick
- comply with the plan dimensions for back boilers.

In some cases, the provision of a hearth is not required, eg where the flame or incandescent material is at least 225mm above the floor.

For all forms of gas appliances, the hearths should be marked at the edges to:

- provide a warning to the home owner
- discourage combustible floor finishes, such as carpet, from being laid too close to the appliance (this can be achieved by introducing a change in level).

Figure 7: Hearth clearances for back boilers

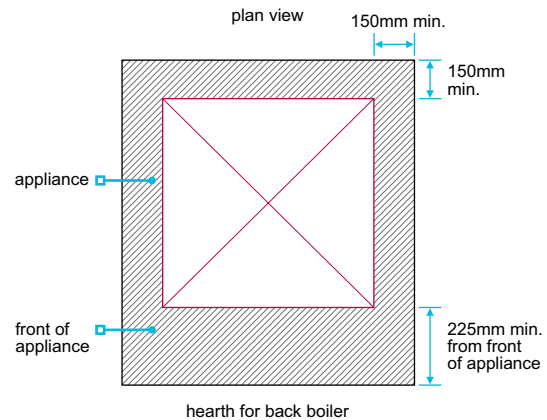

6.8.9 Gas – combustion air

Installations shall be provided with an adequate supply of combustion air.

Gas appliances should have an air supply from external air, either directly or indirectly, to comply with statutory requirements and the manufacturer's recommendations. Full details of ventilation requirements for all types of gas appliances are contained in relevant Building Regulations and BS 5440-2.

6.8.10 Gas – flue pipes

Flue pipes shall safely connect an appliance to a chimney, or a flue to a terminal. Issues to be taken into account include:

- 1) size, direction and jointing
- 2) separation from combustible materials.

6.8.10.1 Size, direction and jointing

Gas flue pipes should:

- not have adjustable draught control
- have a free area which is at least the same size as the outlet of the appliance
- not be horizontal (does not apply to balanced flues)
- if serving open-flued appliances, be vertical where possible. Where this is not possible, pipes should not be more than 45° from the vertical. The use of calculations to prove the acceptance of flue pipes installed at an angle exceeding 45° from the vertical is not acceptable
- be fixed in accordance with the manufacturer's recommendations
- be fixed socket up (as appropriate) and be correctly aligned
- where they are long, have support directly below each socket, with a maximum spacing of 1.8m
- have appropriate access for inspection and be in accordance with relevant Building Regulations.

When connecting flue pipes to flue blocks and ridge terminals, proprietary connectors should be used.

Figure 8: Gas flue pipe support distances

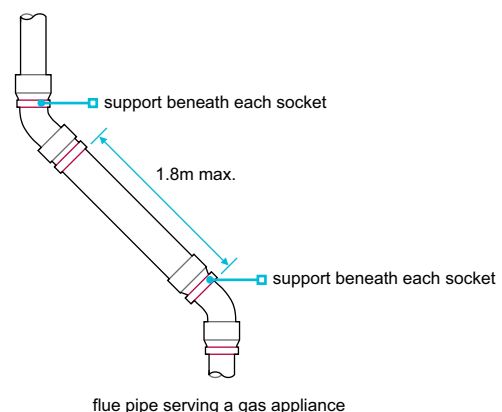

6.8.10.2 Separation from combustible materials

Single wall flue pipes should be separated from combustible materials by:

- a minimum of 25mm
- a non-combustible casing material with at least half the fire resistance of the separating wall or floor, where they pass through a compartment wall or compartment floor, or
- a non-combustible sleeve with a minimum 25mm air space around the pipe, where it passes through a wall, floor or roof.

Where double-walled flue pipes are used, the 25mm separation distance may be measured from the outside of the inner pipe.

6.8.11 Gas – chimneys

Chimneys shall incorporate flues capable of safely conducting products of combustion from an appliance to the external air. The structure shall be capable of supporting the flue and providing adequate protection to adjacent materials. Issues to be taken into account include:

- 1) flues and flue liners
- 2) chimneys.

6.8.11.1 Flues and flue liners

Flue blocks for use with gas appliances should comply with BS EN 1858 (concrete) or BS EN 1806 (clay).

Table 2: Gas flue sizes

	Serving	Minimum flue size
Non fan-assisted individually flued gas burning appliances up to 70kW input (net), excluding balanced flue	Gas fire	Either: <ul style="list-style-type: none"> • a circular flue with a minimum 12,000mm² cross-sectional area (125mm diameter), or • a rectangular flue with a minimum 16,500mm² cross-sectional area and a minimum dimension of 90mm.
	Any other	<ul style="list-style-type: none"> • at least the cross-sectional area of the outlet from the appliance.
Inset live or decorative gas fuel effect appliances	Open fire within a fireplace opening up to 500mm x 550mm	<ul style="list-style-type: none"> • either a circular or rectangular flue with a minimum dimension of 175mm.

Rigid metal flue liners and chimneys should comply with BS EN 1856 or be as described in Clause 6.8.6.2 (as appropriate). Flexible flue liners are not acceptable in a new build.

6.8.11.2 Chimneys

Chimneys for gas appliances must not incorporate an adjustable draught control.

Masonry chimneys

Flues within masonry chimneys should be in accordance with the requirements relevant to flues for solid fuel appliances (see Clause 6.8.6.2).

Brickwork or blockwork chimneys for gas appliances should, at minimum, have the same level of fire resistance as each compartment wall or floor which it forms part of, or passes through. The compartment wall may form the chimney wall where it is a masonry material of suitable thickness.

Terminals to masonry chimneys should:

- where proprietary, comply with BS EN 1856, BS EN 1858 and the appliance manufacturer's recommendations
- where proprietary products are not used, have a free opening area a minimum of 2x the area of the flue; there should be openings (6-25mm in diameter) distributed uniformly around the terminal or on two opposite faces.

Flue block chimneys

Flue block chimneys can only be used for certain types of gas appliances and should be:

- compliant with BS EN 1858 (if concrete) or BS EN 1806 (if clay/ceramic), with a minimum performance class of FB4 N2
- constructed using units suitable for the appliance
- constructed, jointed and weatherproofed in accordance with the design and the manufacturer's instructions
- correctly bonded to the flanking masonry
- clean and sealed
- checked for suitability, before connecting any appliance.

Connections between flue blocks and ridge terminals should be made:

- in accordance with the design
- using the correct fittings and supports as specified by the manufacturers of the flue blocks, flue pipe and ridge terminal.

Gas flue blocks are at least 140mm wide. Where this is wider than the wall leaf:

- the extra thickness should be incorporated by increasing the overall width of the cavity
- the flue block should be installed flush with the inside of the cavity and project into the room as a false chimney breast, or
- where the cavity is reduced, the flue block should be protected by a vertical DPM supported by a layer of non-combustible insulation, in accordance with the manufacturer's instructions.

Figure 11: Precast flue block cavity wall insulation and vertical DPM

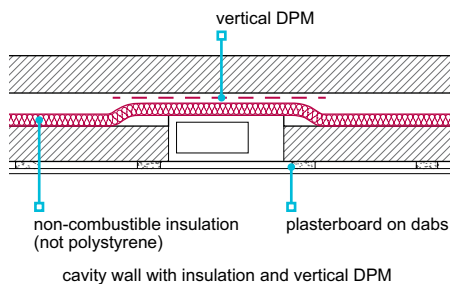

Flue blocks should not be:

- built into separating walls unless it can be shown that the wall has adequate sound resistance

Figure 9: Gas precast flue blocks to ridge terminal — cross-section

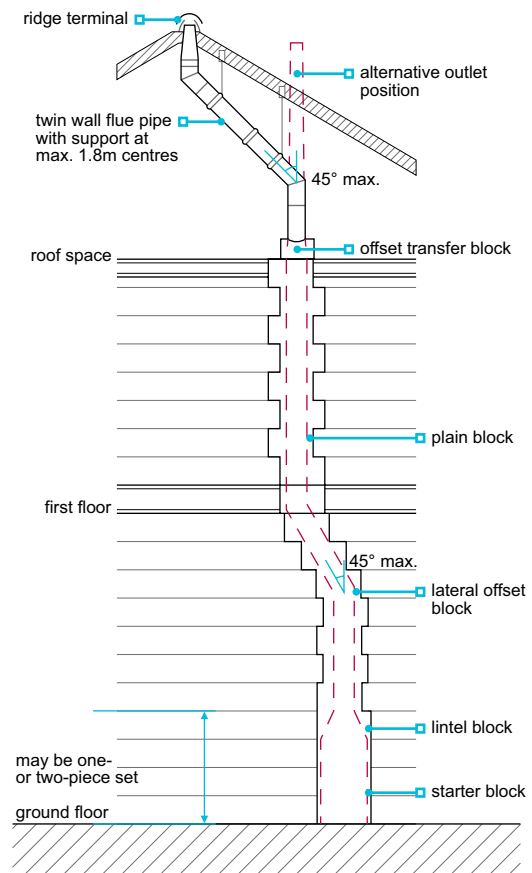

Figure 10: Gas precast flue blocks to ridge terminal transition

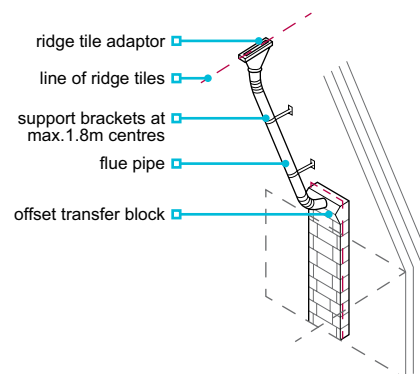
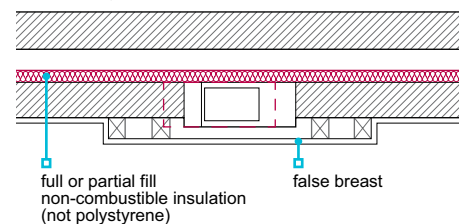

Figure 12: Precast flue blocks — false chimney breast arrangement with insulated cavity wall



- plastered; a plasterboard lining with an air space or non-combustible insulation behind it should be provided (insulated dry lining may be unsuitable in this situation unless separated from the flue block).

Factory-made insulated chimneys

Factory-made insulated chimneys should:

- be assembled, erected, anchored and protected in accordance with the manufacturer's instructions
- comply with BS EN 1856 and be installed in accordance with BS 6461, BS EN 15287-1 or BS 5440-1, as appropriate.

6.8.12 Gas – outlets and terminals

Outlets and terminals shall be adequately separated from combustible material and other parts of the home, and prevent the ingress of damp.

Relevant standards and guidance for gas appliances, chimneys and flue terminals:

BS 5440-1	Flues
IGE/UP/7	Gas installation in timber framed and light steel framed buildings

Table 3: Minimum separation distances for gas outlets (mm)

Location	Balanced flue		Open flue	
	Natural draught	Fanned draught	Natural draught	Fanned draught
A Below an opening ⁽¹⁾	Appliance rated heat input (net)		(3)	300
	0-7kW	300		
	>7-14kW	600		
	>14-32kW	1,500		
	>32-70kW	2,000		
B Above an opening ⁽¹⁾	0-32kW	300	(3)	300
	>32-70kW	600		
C Horizontally to an opening ⁽¹⁾	0-7kW	300	(3)	300
	>7-14kW	400		
	>14-70kW	600		
D Below gutters, soil pipes or drain pipes	300		(3)	75
E Below eaves	300		(3)	200
F Below a balcony or carport roof	600		(3)	200
G From a vertical drainpipe or soil pipe	300		150 ⁽⁴⁾ (3)	150
H From an internal or external corner, or to a boundary alongside the terminal ⁽²⁾	600		(3)	200
I Above ground, roof or balcony level	300		(3)	300
J From a surface or a boundary facing the terminal ⁽²⁾	600		(3)	600
K From a terminal facing the terminal	600		(3)	1,200
L From an opening in the carport into the building	1,200		(3)	1,200
M Vertically from a terminal on the same wall	1,500		(3)	1,500
N Horizontally from a terminal on the same wall	300		(3)	300
P From a structure on the roof	N/A	N/A		1,500 (for a ridge terminal) 2,000 (for any other terminal, as given in BS 5440-1)
Q Above the highest point of intersection with the roof	N/A	Site in accordance with manufacturer's instructions		Site in accordance with BS 5440-1
				150

Notes

1. An opening here means an openable element, such as an openable window, or a fixed opening, such as an air vent. However, in addition, the outlet should not be nearer than 150mm (fanned draught) or 300mm (natural draught) to an opening into the building fabric formed for the purpose of accommodating a built-in element, such as a window frame.
2. Boundary as defined in paragraph 0.4. of Approved Document J: smaller separations to the boundary may be acceptable for appliances that have been shown to operate safely with such separations from surfaces adjacent to, or opposite, the flue outlet.
3. Should not be used.
4. This dimension may be reduced to 75mm for appliances of up to 5kW input (net).

Terminal guards should be fitted over all gas flue terminals where persons could come into contact with the terminal, or it could be damaged.

BS 5440-1 advises that, in the absence of any specific guidance from the appliance manufacturer, terminals less than 2m above ground, above a balcony, or above a flat roof which people have access to, should be guarded.

The appliance manufacturer may specify a suitable terminal guard. Generally, no part of the guard should be less than 50mm from any part of the terminal when fitted in accordance with the manufacturer's instructions.

The guard should not have any sharp edges, which could cause injury, and openings in the guard should admit a 6mm diameter ball without force, but not a 16mm diameter ball.

Where a flue outlet is not serving a balanced flue appliance, it should be:

- situated at roof level, so that air can pass freely across it at all times
- a minimum of 600mm from openings, and at least 2,000mm where below a roof window
- fitted with a flue terminal where the flue diameter is less than 170mm (larger diameter flues should be fitted with a terminal where required by Building Regulations).

Figure 13: Gas flue terminal positions

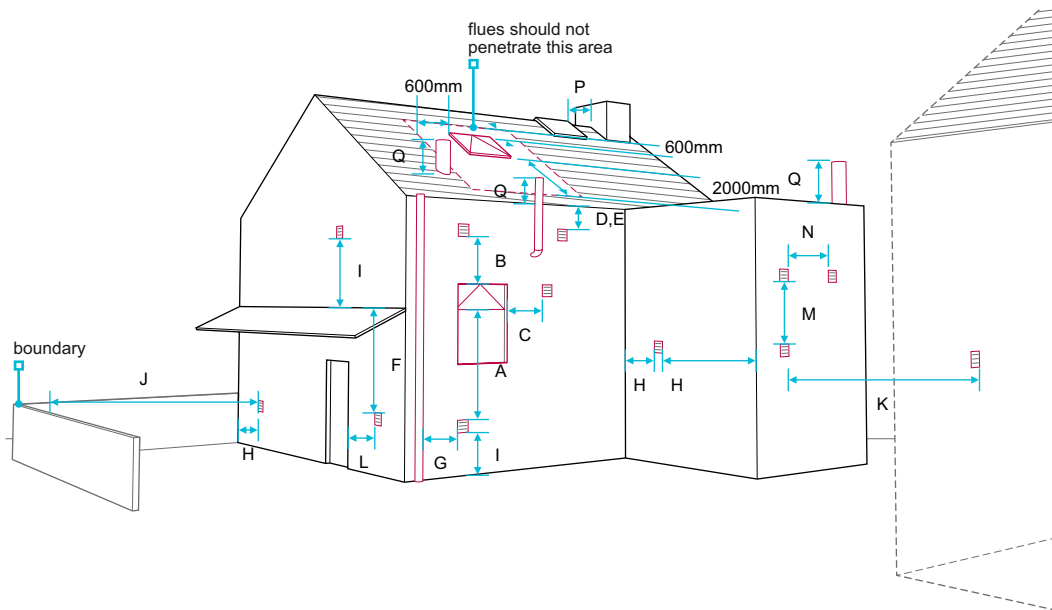

Precautions should be taken, where appropriate, to prevent damp penetration in accordance with the requirements for resistance to frost attack and weathering for solid fuel appliances (see Clauses 6.8.6.3 and 6.8.6.4).

All flues which bridge the cavity of an external wall should have a means of preventing moisture crossing the cavity, eg a moisture drip collar set in the centre of the cavity. For timber frame construction, the guidance in IGE/UP/7 should be adopted in relation to non-combustible sleeving and to maintain the integrity of the vapour control layer (VCL).

Where cavity trays and weepholes are used, they should be in line with Chapter 6.1 External masonry walls.

Figure 14: Drip collar for circular flues — cross-section

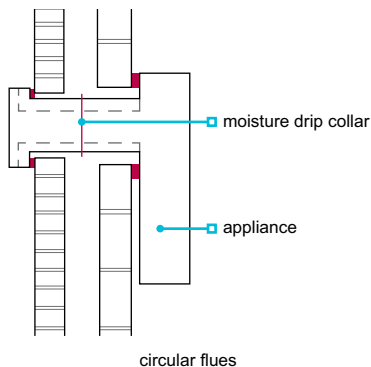
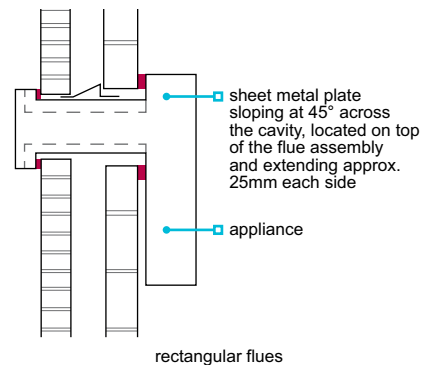

Figure 15: Drip collar plate detail for rectangular flues — cross-section



6.8.13 Liquid fuel – fireplaces and hearths

Fireplaces and hearths shall safely accommodate the fire or appliance and be suitably separated from combustible materials.

Where the temperature of the hearth below the appliance is:

- likely to exceed 100°C, or the temperature is not known, precautions should be in accordance with the requirements for hearths for solid fuel appliances (see Clause 6.8.3).
- unlikely to exceed 100°C, the appliance may stand on a rigid, non-combustible imperforate sheet of material without a constructional hearth.

Where appliances are likely to have back or side temperatures exceeding 100°C, hearths and shielding should be in accordance with the requirements for gas appliances (see Clause 6.8.8).

6.8.14 Liquid fuel – combustion air

Installations shall be provided with an adequate supply of combustion air.

Liquid fuel appliances should have an air supply from external air, either directly or indirectly, to comply with statutory requirements and the manufacturer's recommendations. Full details of ventilation requirements for all types of appliances are contained in relevant Building Regulations.

6.8.15 Liquid fuel – flue pipes

Flue pipes shall safely connect an appliance to a chimney.

Flue pipes should:

- have a free area which is at least the same size as the outlet of the appliance
- if serving open-flued appliances, be vertical where possible. Where this is not possible, pipes should not be more than 45° from the vertical. A horizontal section, less than 150mm long, may be used to connect a back outlet appliance to a flue.

6.8.16 Liquid fuel – chimneys

Chimneys shall incorporate flues capable of safely conducting products of combustion to the external air. The structure shall be capable of supporting the flue lining and shall provide adequate protection to adjacent materials. Issues to be taken into account include:

- 1) stability, size and direction
- 2) separation from adjacent spaces, materials and combustible materials
- 3) flue liners
- 4) resistance to frost/chemical attack
- 5) resistance to weather.

6.8.16.1 Stability, size and direction

Flue pipes should:

- have a free area which is at least the same size as the outlet of the appliance
- if serving open-flued appliances, be vertical where possible. Where this is not possible, pipes should not be more than 45° from the vertical.

Factory-made, metal insulated chimneys should:

- be designed in accordance with BS EN 1856 and BS EN 1859 and installed in accordance with BS EN 15287, or be assessed in accordance with Technical Requirement R3
- have a minimum operating life of 30 years
- where they are part of a component system, comply with BS EN 1856 and be installed in accordance with manufacturer's instructions.

6.8.16.2 Separation from adjacent spaces, materials and combustible materials**Table 4:** Protecting buildings from hot flues for flue gas temperatures not more than 250°C

Flue within:	Protection measures
Connecting flue pipe	Flues should be a minimum of 25mm from any combustible material. This is measured from the outer surface of the flue wall and the inner wall of multi-walled products.
Factory-made chimney complying with BS EN 1856	Where flues pass through a combustible wall, floor or roof (other than a compartment wall, floor or roof), separation can be achieved through the use of a non-combustible sleeve around the flue pipe or chimney with a 25mm air space to the relevant flue wall. The air space could be wholly, or partially, filled with non-combustible insulating material.
Factory-made chimney complying with BS EN 1856	Refer to appropriate British Standards and manufacturers' recommendations.
Masonry chimney	Provide a minimum of 25mm of masonry between flues and any combustible material.
Flue block chimney	Provide flue block walls a minimum of 25mm thick.
Flue assemblies for roomed-sealed appliances	Flues passing through combustible walls should be surrounded by a minimum of 50mm insulating material. Provide a minimum clearance of 50mm from the edge of the flue outlet to any combustible wall cladding.

6.8.16.3 Flue liners

As for gas flue pipes where the flue gases are unlikely to exceed a temperature of 250°C (see Clause 6.8.10). As for solid fuel flue pipes where the flue gases are likely to exceed a temperature of 250°C or the temperature is not known (see Clause 6.8.5).

Flexible flue liners are not acceptable for new build.

6.8.16.4 Resistance to frost/chemical attack

Resistance to frost attack as for solid fuel (see Clause 6.8.6.3).

6.8.16.5 Resistance to weather

Resistance to weather as for solid fuel (see Clause 6.8.6.4).

6.8.17 Liquid fuel – outlets and terminals

Outlets and terminals shall be adequately separated from combustible material and other parts of the home.

Balanced flue terminals should be positioned to allow free intake of air to the appliance.

Where terminals are of masonry construction, they should be in accordance with the requirements for solid fuel appliances (see Clause 6.8.7.2); otherwise, they should be in accordance with the manufacturer's recommendations.

Table 5: Minimum separation distances for liquid fuel terminals

Location of outlet ⁽¹⁾		Appliance with pressure jet burner (mm)	Appliance with vaporising burner (mm)
A	Below an opening ^(2 & 3)	600	Should not be used
B	Horizontally to an opening ^(2 & 3)	600	
C	Below a plastic/painted gutter, drainage pipe or eaves, where combustible material is protected ⁽⁴⁾	75	
D	Below a balcony or a plastic/painted gutter, drainage pipe or eaves without protection to combustible material	600	
E	From vertical sanitary pipework	300	
F	From an external or internal corner, or from a surface or boundary alongside the terminal	300	
G	Above ground or balcony level	300	
H	From a surface or boundary facing the terminal	600	
J	From a terminal facing the terminal	1,200	
K	Vertically from a terminal on the same wall	1,500	
L	Horizontally from a terminal on the same wall	750	
M	Above the highest point of an intersection with the roof	600 ⁽⁶⁾	1,000 ⁽⁵⁾
N	From a vertical structure to the side of the terminal	750 ⁽⁶⁾	2,300
O	Above a vertical structure which is less than 750mm (pressure jet burner) or 2,300mm (vaporising burner) horizontally from the side of the terminal	600 ⁽⁶⁾	1,000 ⁽⁵⁾
P	From a ridge terminal to a vertical structure on the roof	1,500	Should not be used

Notes

1. Terminals should only be positioned on walls where appliances have been approved for such configurations when tested in accordance with BS EN 303-1.
2. An opening means an openable element, such as an openable window, or a permanently open air vent.
3. Notwithstanding the dimensions above, a terminal should be at least 300mm from combustible material, eg a window frame.
4. To provide protection to combustible material, fit a heat shield at least 750mm wide.
5. Where a terminal is used with a vaporising burner, the terminal should be at least 2.3m horizontally from the roof.
6. Outlets for vertical balanced flues in locations M, N and O should be in accordance with manufacturers' instructions.

6.8.18 All – fireplaces and hearths

Fireplaces and hearths shall safely accommodate the appliances for which they are designed.

Combustible material should not be placed under a constructional hearth unless it is:

- to support the edges of the hearth
- at least 250mm from the material to the top of the hearth, or
- separated from the underside of the hearth by an air space of at least 50mm.

Fireplace recesses should be constructed of solid non-combustible material as shown in the figures (dimensions are based on a 125mm concrete hearth below an open fire). The space between a fire back and masonry forming the recess should be filled with vermiculite concrete (1:4, lime:vermiculite with water).

Figure 16: Hearth clearances

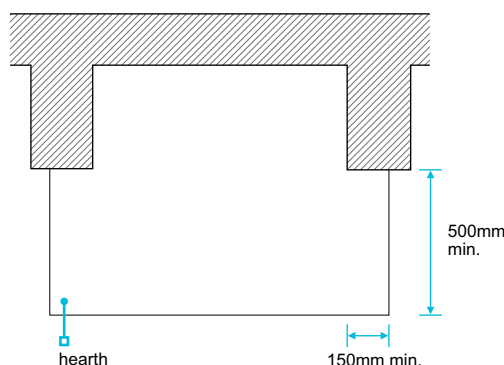

Figure 17: Fireplace recess — external cavity wall projection

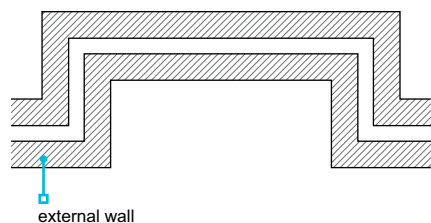

Figure 18: Fireplace recess — external cavity wall with dimensions

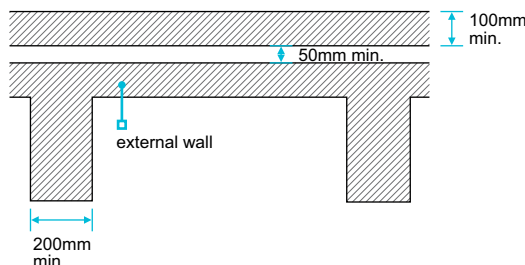

Figure 19: Fireplace recess — internal wall with dimensions

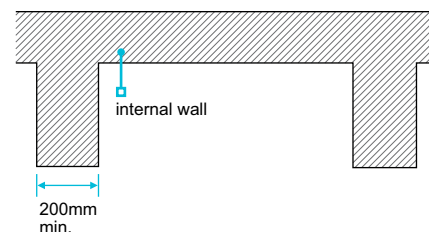

Figure 20: Appliance recess with raft lintel (freestanding heater), front and side view

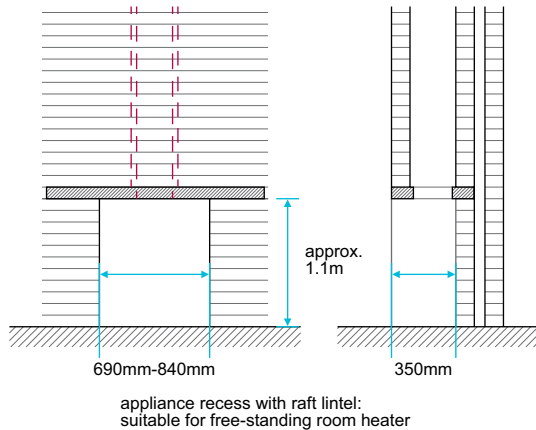
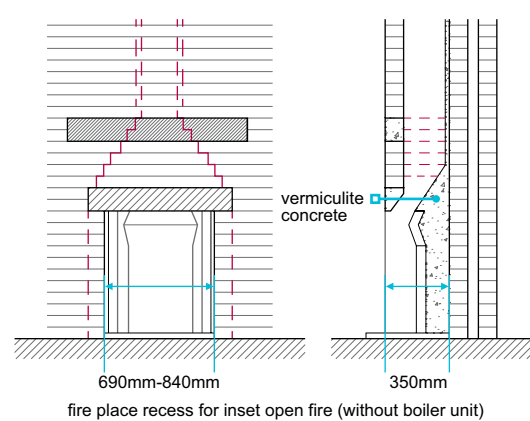

Figure 21: Lintelled opening for inset open fire (chimney throat insert), front and side view



6.8.19 All – fireplace surrounds

Fireplace surrounds and their fixings shall be designed, specified and installed to ensure adequate in-service performance and durability.

The fixing and support should safely accommodate the proposed type of fireplace surround (which could be manufactured in one or a number of pieces), taking into account its size and weight. The walls and floors of the building should safely accommodate the additional load of the proposed fireplace surround.

Fireplace surrounds should be installed by competent operatives, strictly in accordance with the manufacturer's recommendations and fixing specification, and fixed to the structure using mechanical fixings, giving full consideration to:

- the type of material used to manufacture the surround
- the configuration of the surround
- the size and weight of the surround
- the potential for overturning of the surround or parts thereof
- the type of supporting walls and floors, including the structure (eg framed or solid structure) and its finish (eg wallboard or wet finish)
- the type, material, number and location of fixings.

Fixings should be of durable material and be appropriate for the type of surround and the supporting wall or floor to which the surround is to be fixed. Fixings should generally be of stainless steel to BS EN ISO 3506-1 Mechanical properties of corrosion-resistant stainless steel fasteners and be specified to provide suitable strength and durability. Materials that comply with recognised standards which provide equal or better performance are also acceptable.

Methods that rely solely on adhesive for fixing fireplace surrounds to the structure are not acceptable.

More information on the installation of all types of natural and artificial stone fireplace surrounds can be found in the Stone Federation Great Britain Fireplace Surrounds Data sheet.

6.8.20 All – flue pipes

Flue pipes and terminals shall be suitable for their purpose and provide unrestricted passage for combustion gases between the fireplace, or appliance, and the outlet.

The connection between a fireplace, or appliance, and the flue should be correctly constructed.

Figure 22: Throat unit connection to lintel

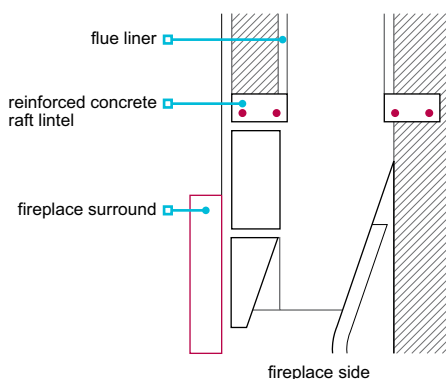

Figure 23: Chimney joint to connecting flue pipe

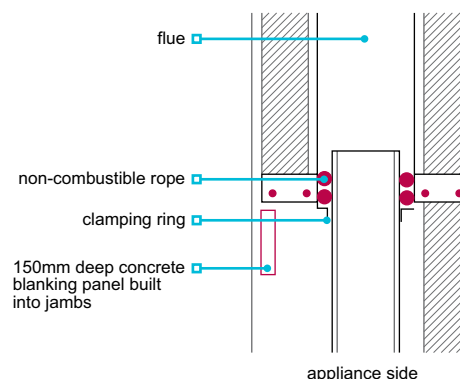
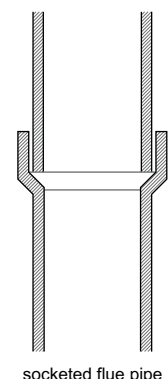

Figure 24: Socketed flue pipe (socket up)



Where the bottom of the flue is not directly over an appliance, it should be provided with a means of access for cleaning and inspection.

Adjustable flue draught control units are not permitted where gas burning appliances are installed. Where adjustable throat units are specified, they should be fitted in accordance with the manufacturer's instructions.

Flue pipes should be jointed in accordance with the manufacturer's instructions, fixed socket up, correctly aligned and jointed.

Table 6: Acceptable standards for flue pipes

Flue material	Guidance
Metal flue pipes for gas appliances	BS EN 1856
Cast iron flue pipes	BS EN 1856
Mild steel flue pipes	BS 1449 (minimum 3mm wall thickness)
Stainless steel flue pipes	BS EN 10088 (minimum 1mm thick) and one of the following grades: 1.4401, 1.4404, 1.4432 or 1.4436
Vitreous enamelled flue pipes	BS EN 1856, low carbon steel coated internally and externally with acid-resisting enamel

6.8.21 All – flue liners

Flue liners shall be unaffected by flue gases and suitable for their purpose.

To produce a suitable flue path, appropriate components should be selected to keep cutting and joints to a minimum. At changes in direction, including bends, offsets and tees, purpose-made components should be used.

Figure 25: Offset chimney with flue liner suitable for solid fuel

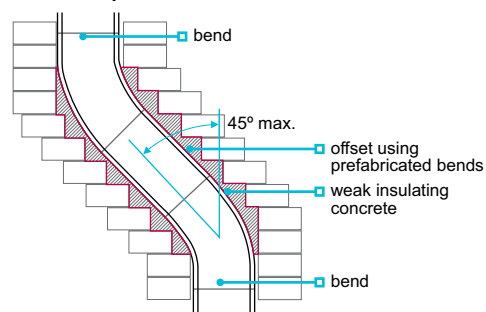

Flue liners should be:

- clay or purpose-made concrete, as specified in the design
- handled carefully to prevent chipping or cracking
- installed in accordance with the manufacturer's instructions and the design
- sealed at their joint with the starter block or throat unit (no cavity should be formed between the linings and the starter elements)
- placed with the sockets or rebate ends facing up.

Liners suitable for solid fuel appliances, and generally suitable for other fuels, include liners whose performance is at least equal to the designation T450 N2 D 3, as described in BS EN 1443, such as:

- clay flue liners with rebates or sockets for jointing meeting the requirements for class A1 N2 or class A1 N1 as described in BS EN 1457
- concrete flue liners meeting the requirements for the classification type A1, type A2, type B1 or type B2 as described in prEN 1857(e18) January 2001, or
- other products that are independently assessed in accordance with Technical Requirement R3.

Alternatively, imperforate clay pipes with sockets for jointing as described in BS 65:1991 are acceptable.

Joints should be made in accordance with the manufacturer's recommendations, generally using:

- fire cement, or
- refractory mortar.

Joints should be fully filled, and surplus material cleared from the inside of each joint as the flue is built.

Spaces between the lining and the surrounding masonry should be:

- filled with weak insulating concrete, or
- in accordance with the manufacturer's recommendations, with the specified material providing adequate protection.

Ordinary concrete should not be used to fill the space between the lining and the surrounding masonry.

Suitable mixtures for weak insulating concrete include:

- one part ordinary Portland cement to 20 parts suitable lightweight expanded clay aggregate, minimally wetted
- one part ordinary Portland cement to six parts vermiculite, or
- one part ordinary Portland cement to 10 parts perlite.

6.8.22 All – flues

Flues shall be suitable for their purpose and adequately separated from combustible materials.

Flues should be:

- suitable for the type and size of appliance which they serve
- tested in accordance with this chapter — see Clause 6.8.29.
- constructed in accordance with the design and the manufacturer's recommendations

Combustible materials close to any brickwork or blockwork chimney should be:

- 200mm minimum from a flue
- 40mm from the face of the chimney, in Scotland.

Metal fixings in contact with combustible materials should be a minimum of 50mm from the flue.

This does not apply to a floorboard, skirting, dado or picture rail, mantel shelf or architrave.

Twin wall flue systems should comply with:

- BS EN 1856, or
- be assessed in accordance with Technical Requirement R3.

6.8.23 All – chimneys

Chimneys shall provide fire protective casing for flues, and shall be capable of adequately supporting the flue liner, while resisting damp penetration and the products of combustion. Issues to be taken into account include:

- 1) construction of chimneys
- 2) typical construction details
- 3) damp penetration and weatherproofing
- 4) coring and drying.

6.8.23.1 Construction of chimneys

Masonry chimneys should be properly bonded to, or supported by, the adjoining walls of the building.

Foundations to a chimney should:

- be the same depth as adjacent wall foundations
- be designed to avoid uneven settlement
- where the chimney forms part of the wall, be a minimum of 100mm wider than the chimney base.

The height (H) of an unrestrained chimney should:

- not exceed 4.5x the smallest dimension on plan of the chimney (W) (where the density of the masonry is a minimum of 1500kg/m³), or
- be designed by an engineer in accordance with Technical Requirement R5.

Chimneys which:

- are of block, brick or stone should have a minimum wall thickness of 100mm, excluding the lining thickness
- are built in a cavity separating wall should form two leaves, each a minimum of 100mm, between the flue and adjoining building
- form part of a compartment wall, and are not back to back with an adjacent chimney, should have a minimum wall thickness of 200mm separating it from the other building or home.

Factory-made insulated chimneys should be assembled, erected, anchored and protected in accordance with the manufacturer's instructions.

Figure 26: Calculating maximum chimney height to width

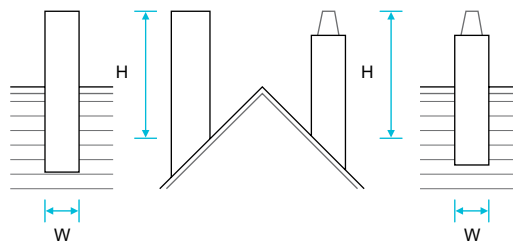

Masonry for chimneys:

- below roof level may be constructed using the same bricks and mortar as used for the general brickwork
- constructed with hollow or cellular blocks should be suitable for the construction of chimneys and filled with concrete as the work proceeds
- should be frost resistant above the roof unless protected by a capping projecting by a minimum of 50mm (in Scotland, frost-resistant bricks should be used for all facing brickwork).

Connections between flue blocks and ridge terminals should be made:

- as detailed in the design
- using the correct fittings and supports as specified by the manufacturers of the flue blocks, flue pipe and ridge terminal.

6.8.23.2 Typical construction details

Figure 27: Plan view of fireplace recess with frame

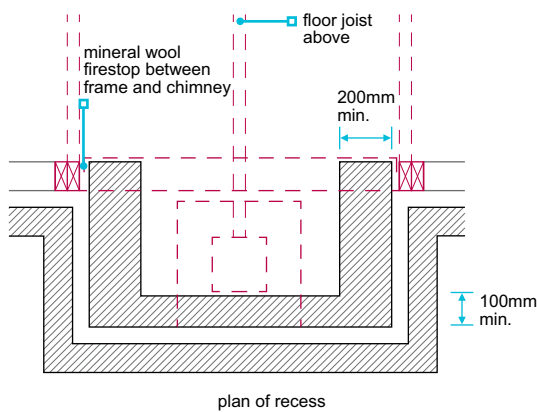

Figure 29: Timber chimney frame construction

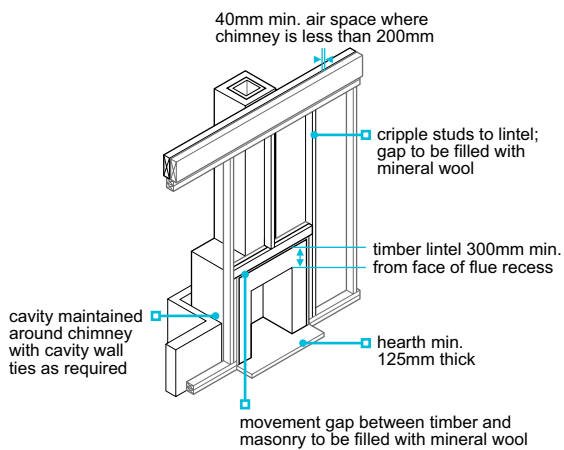
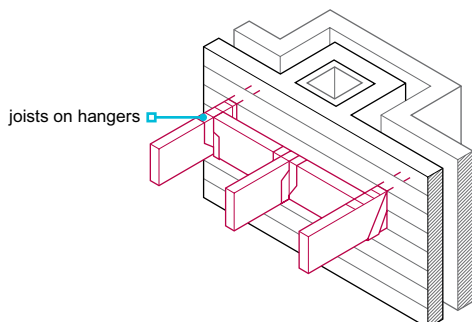

Figure 31: Joist and masonry requirements for Scotland



In Scotland, joists, etc should be min. 200mm from the inner surface of the flue; brickwork or blockwork in chimney construction should be min. 100mm thick with a min. density of 1 600kg/m³; aircrete blocks should be min. 150mm thick.

Figure 28: Plan view of chimney at upper floor level — 40mm airspace where non-combustible material <200mm thick

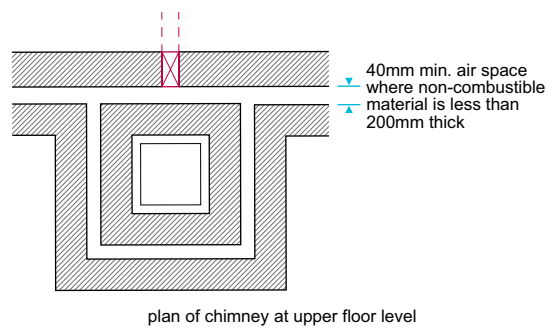

Figure 30: External chimney breast with masonry inner leaf

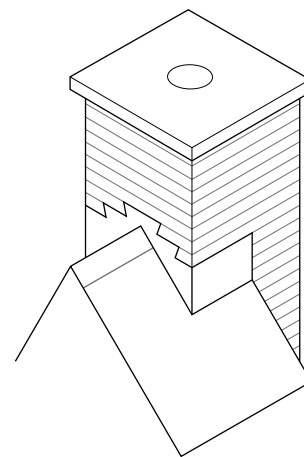

Figure 32: Chimney cavity tray at pitch

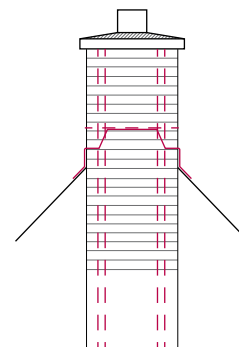

Figure 33: Chimney cavity tray — cross-section (gather)

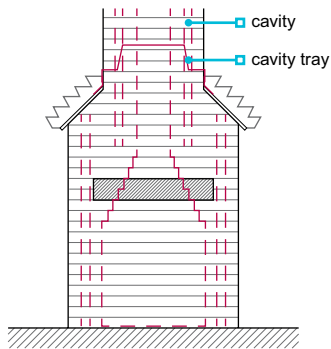
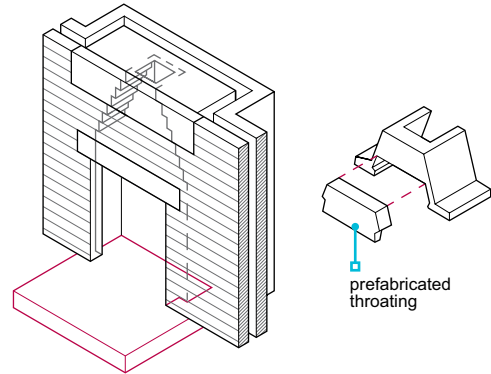

Figure 34: Prefabricated chimney throating



Other alternatives may be suitable, provided they meet the appropriate performance standards.

6.8.23.3 Damp penetration and weatherproofing

Where chimneys exit close to the ridge of a pitched roof, occasional damp penetration may occur below roof level.

In this situation:

- the roof space should be well ventilated
- any dampness penetrating downwards should not reach the living areas.

Where chimneys exit close to the eaves of a pitched roof or through a flat roof, trays and flashings should be installed in the chimney so that all damp penetration is prevented.

DPCs, flashings and gutters should be provided at the intersection point of the chimney with the surface of the roof through which the chimney passes. DPCs to the main walls should be carried through the base of chimneys.

Flashings should be made from compatible non-ferrous metal. Lead trays should be bitumen coated where in contact with cement.

In areas of severe and very severe exposure, the following figures should be used. In lower exposure zones, the tray upturn may be on the outside of the flue liner. All other details are the same.

Figure 35: Chimney flashing and DPC tray (chimney on outside wall)

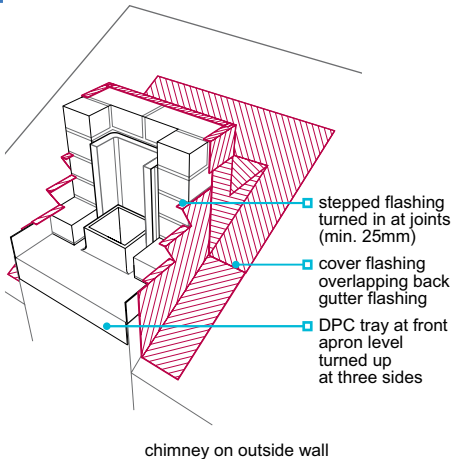

Figure 36: Chimney flashing and DPC tray — stack at ridge

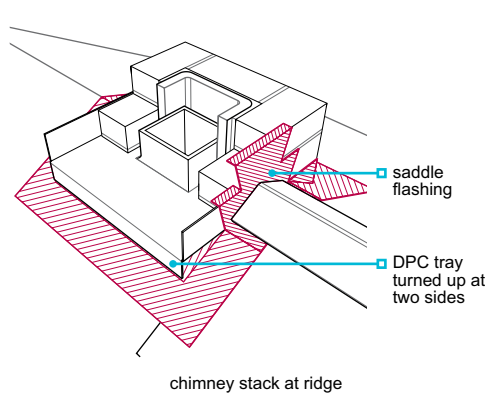
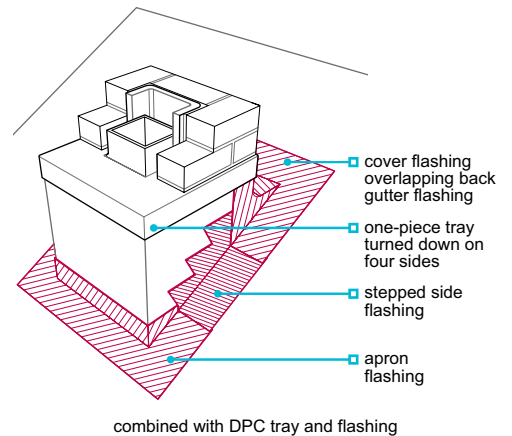

Figure 37: Combined with DPC tray and flashing



6.8.23.4 Coring and drying

Where a core (eg a sack full of loose straw or similar) is used to prevent mortar dropping into the flue liner during construction, the builder should ensure that it is removed on completion of the chimney.

A chimney should be allowed to dry naturally for a minimum period of 14 days before use.

6.8.24 Masonry

Masonry shall be capable of supporting intended loads and have appropriate resistance to the adverse effects of frost and sulfates.

Masonry, including bricks, blocks, stone for masonry and reconstructed stone, should:

- be in accordance with BS 6461 or BS EN 15287-1 and BS EN 771
- where clay bricks are used in external chimney stacks, be of durability rating F2,S1 (as described in BS EN 771) or protected by a projecting capping
- where blocks are used, have a minimum block density of 1500kg/m³ unless designed by an engineer in accordance with Technical Requirement R5.

In Scotland:

- frost-resistant bricks should be used for all external facing brickwork
- where 100mm blocks are used for chimney construction, they should have a minimum density of 1,500kg/m³.

6.8.25 Mortar

Also see: Chapter 6.1

Mortar shall be batched and mixed to achieve adequate strength and durability.

Mortar should be in accordance with Chapter 6.1 External masonry walls and include sulfate-resisting cement where flue gases are liable to affect the masonry, eg above roof level.

6.8.26 DPC

Materials for damp proofing shall adequately resist the passage of moisture into the building.

The following are acceptable for use as DPCs:

- bitumen to BS 6398
- polyethylene to BS 6515 (not to be used in the chimney stack above roof level)
- proprietary materials assessed in accordance with Technical Requirement R3.

6.8.27 Flashings

Flashings and trays shall be capable of adequately resisting the entry of moisture into the building.

Suitable materials for flashings and trays include:

- milled sheet lead, minimum thickness 1.8mm, code blue (Code 4), to BS EN 12588
- zinc alloy complying to BS EN 988 and 0.6mm thick
- proprietary materials assessed in accordance with Technical Requirement R3.

6.8.28 Terminals

Flue terminals shall be suitable for their purpose and assist the functioning of the flue. Issues to be taken into account include:

- 1) draught improvement
- 2) chimney capping.

Relevant standards for flue terminals

BS EN 13502	Chimneys. Requirements and test methods for clay/ceramic flue terminals
BS EN 1858	Chimneys. Components. Concrete flue blocks
BS EN 1856	Chimneys. Requirements for metal chimneys

Terminals should be:

- purpose-made or formed by extending the flue lining a minimum of 20mm above the head of the chimney
- embedded a minimum of 125mm into the chimney, excluding any flaunching, or 0.25x the length of the terminal, whichever is the greater
- the same cross-sectional area as the flue (solid fuel has a minimum requirement of a 200mm diameter).

Figure 38: Purpose made chimney capping (cross section)

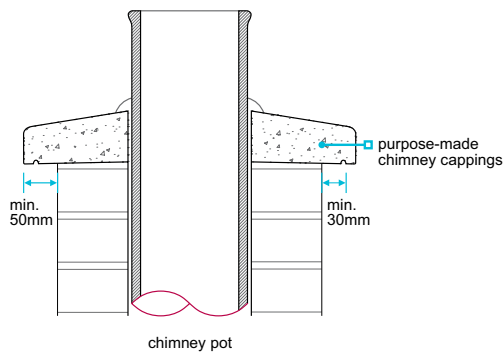
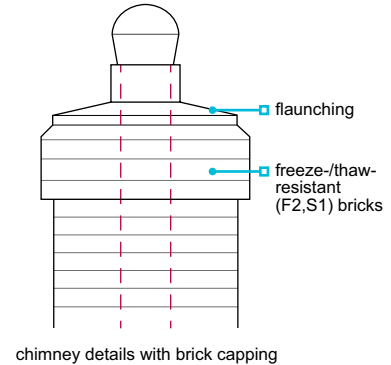

Figure 39: Chimney details with brick capping



The terminal of a masonry flue should be jointed to the flue lining with cement mortar to form a seal.

6.8.28.1 Draught improvement

Where downdraughts may occur, terminals designed to increase updraught should be fitted. However, a terminal will not overcome problems caused by high pressure zones. Where relevant, the Solid Fuel Association or other authoritative body should be consulted.

6.8.28.2 Chimney capping

Where a chimney is to be capped:

- a single unjointed concrete or stone capping should be used
- it should project and be throated to cast water away from the face of the chimney
- the slab should project 50mm beyond the sides of the chimney, with a drip at least 30mm from the sides of the chimney, and the withes between flues should be carried to the underside of the slab.

Decorative brick cappings should be carefully constructed to avoid rain penetration and frost damage. The use of frost-resistant bricks may be required.

In Scotland, bricks used for facing brickwork should be frost resistant.

6.8.29 Flue testing

Installations shall be tested before use.

Flues should be checked during construction to ensure:

- there are no obstructions in the flue
- mortar or other blockages are removed.

When the flue is complete, a visual check should be made and obstructions cleared.

Coring ball test for solid fuel appliances

When a visual test cannot be conducted, or is inconclusive, the coring ball test should be conducted as follows:

- a suitable concrete or metal ball should be attached to a strong cord or rope
- the ball should be slowly lowered from the flue outlet to the bottom of the flue (the fireplace recess or the appliance connection)
- where a blockage or obstruction is found, it must be removed and the test repeated until the flue is completely clear of obstruction.

Smoke test for solid fuel appliances

This test is designed to show that a flue draws adequately and that there are no leaks between the appliance and the terminal. It must be conducted when neither the flue to be tested or adjacent flues are in use. The test should be conducted as follows:

- the flue should be warmed for 10 minutes with a heat source such as a blow lamp. Where an appliance is fitted, all doors, including flue access doors, should be closed
- two purpose-made smoke pellets should be placed in the appliance firebox or in the bottom of the flue and ignited, then, closed or sealed off and the smoke allowed to rise
- when smoke appears at the top of the flue, the outlet should be sealed with a blow-up rubber ball or other airtight closing system
- the whole structure forming the flue should be inspected externally for smoke leakage. This should include the top of cavity walls and any other possible smoke paths, even those terminating some distance from the flue
- the test should be continued for a minimum of five minutes.

Flues for gas appliances

For gas appliances, more sophisticated flue tests may be required and should be conducted by the appliance installer. See appliance manufacturer's instructions and BS 5440-1.

Flues for liquid fuel appliances

Flues for oil-fired appliances should be tested as required by the appliance manufacturer.

6.8.30 Further information

- *BS EN 1856-1 Chimneys — Requirements for metal chimneys — System Chimney products*
- *BS EN 1856-2 Chimneys — Requirements for metal chimneys — Part 2. Metal flue liners and connecting flue pipes*
- *BS EN 1859 Chimneys. Metal chimneys. Test methods*
- *BS EN 15287-1 Chimneys. Design, installation and commissioning — chimneys and connecting flue pipes for non room-sealed combustion appliances*
- *BS EN 15287-2 Chimneys. Design, installation and commissioning — chimneys and connecting flue pipes for room-sealed combustion appliances*
- *BS EN 771 Specification for masonry units*
- *BS 5871 Specification for the installation and maintenance of gas fires, convector heaters, fire/back boilers and decorative fuel effect gas appliances*
- *BS EN 1858 Chimneys. Components. Concrete flue blocks.*
- *BS EN 1806 Chimneys. Clay/ceramic flue blocks for single wall chimneys. Requirements and test methods*
- *BS 5440-1 Chimneys, flue pipes and ventilation for gas appliances of rated input not exceeding 70kW net (1st, 2nd, and 3rd family gases) — Design, installation, commissioning and maintenance of chimneys. Specification*
- *BS 5440-2 Chimneys, flue pipes and ventilation for gas appliances of rated input not exceeding 70kW net (1st, 2nd, and 3rd family gases) — Installation and maintenance of ventilation provision for gas appliances. Specification*
- *IGE/UP/7 Gas installations in timber framed and light steel framed buildings*
- *BS EN 303-1 Heating boilers — Heating boilers with forced draught burners. Terminology, general requirements, testing and marking*
- *BS EN ISO 3506 Fasteners. Mechanical properties of corrosion-resistant stainless steel fasteners*
- *BS 1449 Steel plate, sheet and strip. Carbon and carbon-manganese plate, sheet and strip*
- *BS EN 10088 Stainless steels*
- *BS EN 1443 Chimneys. General requirements*
- *BS EN 1457 Chimneys. Clay/ceramic flue liners*
- *BS 65 Specification for vitrified clay pipes, fittings and ducts, also mechanical joints for use solely with surface water pipes and fittings*
- *BS 6398 Specification for bitumen damp-proof courses for masonry*
- *BS 6515 Specification for polyethylene damp-proof course for masonry*
- *BS EN 988 Zinc and zinc alloys. Specification for rolled flat products for building*
- *BS EN 13502 Chimneys. Requirements and test methods for clay/ceramic flue terminals*
- *BS 5410-1. Code of practice for liquid fuel firing — Installations for space heating and hot water supply purposes for domestic buildings*



Chapter 6.9



Curtain walling and cladding

This chapter gives guidance on meeting the Technical Requirements for curtain walling and cladding.

6.9.1	Compliance	04
6.9.2	Provision of information	04
6.9.3	Certification	04
6.9.4	Loads	04
6.9.5	Support and fixings	05
6.9.6	Durability	06
6.9.7	Interfaces	06
6.9.8	Insulation	06
6.9.9	Damp proofing and vapour control	07
6.9.10	Installation and tolerances	08
6.9.11	Electrical continuity and earth bonding	08
6.9.12	Maintenance	08
6.9.13	Glazing, gaskets and sealants	09
6.9.14	Cavity barriers and firestops	09
6.9.15	Ventilation screens	09
6.9.16	Handling and storage	09
6.9.17	Curtain walling	10
6.9.18	Rainscreen cladding	12
6.9.19	Insulated render and brick slip cladding	13
6.9.20	Further information	15



Figure reference table

Figure Reference Table 6.9

Fig No	Title/Description	Clause	Page
Figure 1	Curtain walling	6.9	2
Figure 2	Rainscreen cladding	6.9	2
Figure 3	Insulated render	6.9	2
Figure 4	Brick slip cladding	6.9	2
Figure 5	Insulated backing wall to rainscreen cladding	6.9.8	7
Figure 6	Insulated render with drained cavity	6.9.8	7
Figure 7	Brick slip cladding with drained cavity	6.9.8	7
Figure 8	Curtain walling to insulated render system — horizontal section	6.9.17.2	10
Figure 9	Curtain walling to balcony/terrace: vertical section	6.9.17.2	10
Figure 10	Curtain walling to conventional brick and block wall: horizontal section	6.9.17.2	10
Figure 11	Curtain walling to soffit: vertical section	6.9.17.2	10
Figure 12	Curtain walling to roof, including coping detail: vertical section	6.9.17.2	10
Figure 13	Frame perimeter weathersealing gasket	6.9.17.4	11
Figure 14	Cladding panel joint types and spacings	6.9.18.2	12
Figure 15	Compartmentation to achieve pressure equalisation	6.9.18.5	13
Figure 16	Insulated render system to timber frame or light steel frame wall	6.9.19.1	13
Figure 17	Insulated render system to windows and doors: horizontal section	6.9.19.1	14
Figure 18	Penetration of gas flue through insulated render system on light gauge steel frame: horizontal section	6.9.19.1	14
Figure 19	Brick slip cladding to insulated render system: horizontal section	6.9.19.1	14
Figure 20	Reinforcement mesh bonded to blockwork	6.9.19.4	14
Figure 21	Setting out of insulation layer and brick slip carrier system	6.9.19.5	15

Introduction

This chapter gives guidance on the forms of curtain walling and cladding acceptable to NHBC. Curtain walling and cladding systems that do not conform to the descriptions in this chapter will not generally be acceptable. Conservatories are not covered by this chapter.

Guidance on the use of other types of cladding, including brickwork, rendered masonry, vertical tile and slate cladding and timber cladding, is given in Chapter 6.1 External masonry walls and Chapter 6.2 External timber framed walls.

Curtain walling

Comprising a prefabricated or site-assembled support framework, with infill panels and/or wall sections with glazing systems which include:

- structural silicone glazing
- mechanically fixed structural glazing
- slope glazing, excluding patent glazing
- coupled door and window frame assemblies (including spandrel panels) which are one storey or more in height, or not contained between a floor and ceiling.

Figure 1: Curtain walling

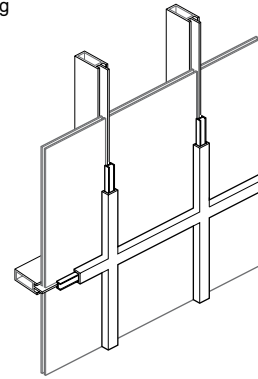

Rainscreen cladding

Comprising:

- an outer skin of panels which have unsealed, open, baffled or labyrinth (rebated) joints
- a minimum 50mm pressure equalised air gap between the insulation and the panels
- an insulated and airtight backing wall.

Figure 2: Rainscreen cladding

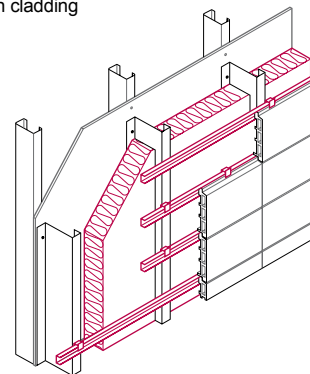

Insulated render

Comprising insulated render systems fixed to a backing wall.

Figure 3: Insulated render

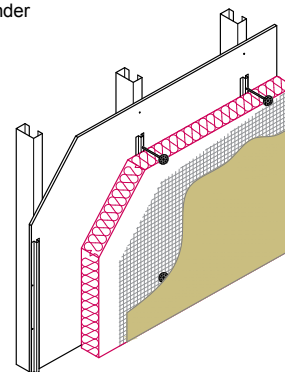

Brick slip cladding

Comprising brick slip cladding fixed to a backing wall.

Figure 4: Brick slip cladding

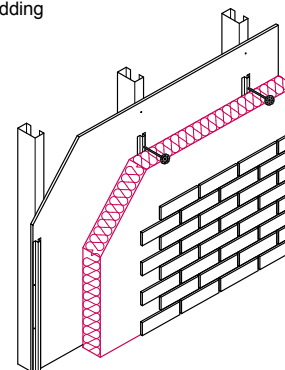

Stone and precast concrete cladding

Stone and precast units should be designed as curtain walling or rainscreen cladding in accordance with this chapter.

Definitions for this chapter

Air barrier	A continuous layer that limits air leakage through the backing wall.
Air cushion	Balancing external and internal air pressure to create a cushion within the air gap.
Air gap	The space between the back of the cladding panels and the external face of the insulation in a rainscreen system.
Backing wall	A framed or masonry wall to which the system is fixed.
Brick slip cladding system	A brick slip system fixed to masonry or framed backing walls, generally supported by a proprietary carrier.
Cavity	The space between the cladding system and the backing wall. The cavity should be adequately drained, and ventilated where required.
Cladding panels	The outer units of a rainscreen cladding system which provide some protection.
Compartmentation	The provision of baffles and cavity closers to form compartments within the air gap of a rainscreen cladding system to equalise pressure.
Curtain walling	A form of enclosure that supports no load other than its own weight and the environmental forces that act upon it, eg wind, water and solar.
Curtain walling system	The vertical building enclosure system, including frames, brackets, fixings, flashings, gutters, copings, glass, panels, gaskets and sealant, that forms the assembly.
CWCT	The Centre for Window and Cladding Technology at Bath University.
CWCT Standard	The current Centre for Window and Cladding Technology Standard for systemised building envelopes.
Design life	The period for which materials, products and systems should be designed to be durable, assuming routine inspection and maintenance.
DPC/DPM	Prevents the passage of moisture. In curtain walling terminology, a DPC is often referred to as a DPM.
Earthing System	Part of a lightning protection system that terminates the current and transfers it safely to the ground.
EPDM	EPDM (ethylene propylene diene monomer rubber) is a type of synthetic rubber that is used in construction waterproofing and sealing applications.
Façade	The external facing part of the building envelope.
Fire-stop and smoke stopping	Prevention of the transmission of fire and smoke through voids or cavities.
Fixing	Componentry used to attach or secure other components, eg curtain walling or a cladding system, to the structure.
Gasket	A compressible material used to form an airtight and/or watertight seal.
In-service performance	The manner or quality of functioning of a material, product or system.
Insulated render system	A cladding system applied externally to an insulating layer which is fixed to a backing wall.
Interstitial condensation	Condensation caused by vapour from within the building condensing on colder surfaces within the wall construction, often occurring due to a cold bridge.
Negative pressure	Where the air pressure on the internal face of the system is greater than that on the external face.
Positive pressure	Where the air pressure on the external face of the system is greater than that on the internal face.
Pressure equalisation	The creation of an air cushion within the cavity to reduce the amount of water passing through the joints of a rainscreen. Compartmentation and adequately large joints are required to achieve pressure equalisation.
Primary components	Components and parts of the system that are not easily replaceable. These may include: <ul style="list-style-type: none"> • cladding panels • fixings • framing • insulation • vapour control layers • weathering components.
Rainscreen	The part of the assembly, generally the outermost, that prevents the majority of rain from penetrating the wall. Some water may pass through the joints of a rainscreen, but this should be limited by appropriate detailing of open joints or the provision of baffled or labyrinth joints.
Rainscreen cladding system	A façade that provides a barrier to wind and rain and which typically includes a vapour control layer, air barrier, supporting framework and fixings, insulation, breather membrane, cavity/air gap and cladding panels. Traditional tile hanging and timber cladding are not classed as rainscreen cladding systems under the definitions of this chapter.
Replaceable components	Those which are readily replaceable without compromising the design and durability of the building or the need for progressive dismantling of the envelope. Where this cannot be achieved, components should be designed as primary components. A method statement should be provided to demonstrate how components will be replaced with specific reference to accessibility as detailed in this chapter.

Secondary components	Components and parts of the system that are easily replaceable. These may include: <ul style="list-style-type: none"> • cladding panels • external finishes • glazing and gaskets • internal linings • seals and sealant • window and door furniture.
Separating floors and walls	Floors and walls designed to provide separation between homes.
Slope glazing	A drained and ventilated sloped roofing system.
Spandrel panel	A panel used in place of glazing units to hide the edges of floor slabs, ceiling details, insulation, and other building elements.
Systems	For the purposes of this chapter, this term refers to acceptable forms of curtain walling, rainscreen cladding, insulated render systems and brick slip cladding systems.
Test pressure	The pressure at which testing is conducted.
Vapour control layer (VCL)	A layer used to restrict the passage of water vapour into the construction to reduce the risk of interstitial condensation.

6.9.1 Compliance

Also see: Chapter 2.1

Curtain walling and cladding systems shall comply with the Technical Requirements.

Curtain walling and cladding systems that comply with the guidance in this chapter will generally be acceptable.

6.9.2 Provision of information

Designs and specifications shall be produced in a clearly understandable format, include all relevant information and be distributed to appropriate personnel.

Clear and fully detailed drawings should be available on site to enable work to be carried out in accordance with the design. Design and specification information should be issued to site supervisors, relevant specialist subcontractors and suppliers, and include the following information:

- a full set of drawings
- a schedule of revisions
- manufacturer's specification
- specific details of all interfaces
- fixing schedules
- manufacturer's recommendations for proprietary items
- details of the on-site testing regime.

6.9.3 Certification

Curtain walling and cladding systems shall be adequately tested, certified and designed in accordance with appropriate standards.

Curtain walling and cladding systems should have certification confirming satisfactory assessment, undertaken by an independent technical authority. Where applicable, certification should be in accordance with the CWCT Standard for systemised building envelopes (or a suitable alternative acceptable to NHBC). UKAS Accredited Independent technical approvals authorities acceptable to NHBC include:

- British Board of Agrément (BBA)
- Building Research Establishment (BRE), or
- UL International (UK) Ltd
- accredited certification bodies considered by NHBC to be a suitable alternative.

Certification and test documentation should be:

- made available to NHBC before work begins on site
- used as reference to ensure compliance.

The use of the system should be within the scope of the certification and test documentation.

6.9.4 Loads

Curtain walling and cladding systems, including brackets and fixings, shall allow movement without causing damage or deformation, and safely transfer loads to the building.

Dead loads and live loads should:

- be transferred safely to the building's structure without undue permanent deformation or deflection of any component
- be calculated in accordance with BS EN 1991-1-1 and BS EN 1991-1-4, and taking into account internal and external pressures and the location, shape and size of the building.

The following should be accommodated without any reduction in performance:

- thermally induced loading due to differential stresses caused by temperature gradients within materials or components
- stresses in components and materials (these should not exceed the permissible values recommended by the product manufacturer)
- movement within the curtain walling or cladding.

Causes of movement include:

- dead and live loads
- changes in temperature
- changes in the moisture content of components
- freezing of retained moisture
- creep.

Allowance for movement should be provided in accordance with the design.

6.9.5 Support and fixings

Curtain walling and cladding systems shall be securely fixed with suitably durable fixings to ensure adequate in-service performance.

The cladding system and associated fixings should be correctly located and securely fixed in accordance with the design and the manufacturer's recommendations. Fixings and supports, including the type, size and positioning of anchors, fixing rails, frames, fixings, fasteners and bracketry, should be in accordance with the design, and:

- accommodate specified loads
- account for packing of brackets to achieve surface tolerance, in accordance with the manufacturer's recommendations
- be accurately set out
- generally be stainless steel, suitable non-ferrous metal or appropriate plastics
- be installed ensuring dissimilar metals are separated to avoid bimetallic corrosion
- be installed ensuring aluminium components are separated from direct contact with cementitious surfaces.

Mechanically fixed systems should be in accordance with the manufacturer's recommendations, and fixings should:

- have the correct embedding, spacing and edge distances
- be installed to the correct torque settings
- have suitable locking nuts and washers.

Fixings should be manufactured from:

- phosphor bronze
- silicon bronze
- BS EN ISO 3506 stainless steel
- mild steel with coatings to BS EN ISO 2081, BS EN 1461, or other appropriate treatment in accordance with BS EN ISO 12944 or BS EN ISO 14713
- BS EN 573 and BS EN 755 aluminium alloy
- appropriate plastics
- materials assessed in accordance with Technical Requirement R3.

Materials that comply with recognised standards and which provide equivalent or better performance to those above will generally be acceptable to NHBC.

Pull-out or destructive testing of anchors and fixings should:

- comply with BS 8539 and BS 5080
- comply with the Construction Fixings Association Guidance Note 'Procedure for Site Testing Construction Fixings'
- be carried out in accordance with the design
- be carried out at a frequency agreed with NHBC.

The test report should be made available to NHBC.

Adhesive-fixed systems should be installed to a suitably prepared backing wall, providing:

- an assessment of the backing wall is available to confirm suitability
- it is used in accordance with the design.

Adhesive fixing of rails, frames, fixings and fasteners should:

- only be specified where there is no suitable alternative
- be used in accordance with the manufacturer's recommendations.

Timber should only be used where it is:

- easily inspected and replaced without disturbing the curtain walling system
- treated in accordance with Chapter 3.3 Timber preservation (natural solid timber).

6.9.6 Durability

Also see: Chapter 3.3

Curtain walling and cladding systems shall provide satisfactory durability (subject to routine inspection and maintenance). Timber shall be either naturally durable or preservative treated to provide adequate protection against rot and insect attack.

The system should be designed to avoid the need for disproportionate work when repairing or replacing individual components. In addition:

- primary components should provide satisfactory in-service performance for the design life of the building
- secondary components should provide satisfactory in-service performance for a minimum of 25 years.

The curtain walling system should be constructed with corrosion-resistant or adequately protected materials. The risk of bimetallic corrosion should be avoided by the isolation of dissimilar metals.

Systems should not include materials liable to infestation by micro-organisms, fungi, insects or vermin.

6.9.7 Interfaces

Curtain walling and cladding systems shall have suitable interfaces and resist the penetration of water and wind.

The design should indicate the contractor responsible for constructing interfaces.

Interfaces, including those between curtain walling and cladding systems, and those between curtain walling and cladding systems and other elements of the building (eg walls, roof, doors and windows), should be carefully designed and detailed to be weather resistant, and prevent moisture reaching parts of the wall that it could adversely affect.

The design should take account of:

- differing profile characteristics
- movement
- continuity of insulation, vapour barriers and breather membranes
- tolerances and deviation
- the erection sequence
- planned maintenance.

6.9.8 Insulation

Insulation shall be suitable for the intended use.

Insulation should be:

- in accordance with the design and the manufacturer's recommendations
- installed correctly to minimise the risk of thermal bridging, surface and interstitial condensation
- securely fixed to the support frame or backing wall with appropriate fixings and/or adhesive in accordance with the manufacturer's recommendations
- returned into window and door openings, and continuous around penetrations through the wall
- neatly cut around fixings and brackets.

Insulation materials should:

- be inert, durable, rot and vermin proof
- not be adversely affected by moisture
- be one of the materials listed in Table 1.

Table 1: Materials for insulation

Insulation type	Relevant standard
Mineral wool	BS EN 13162
Flame retardant (FR) grade expanded polystyrene (EPS)	BS EN 13163
FR grade extruded polystyrene (XPS)	BS EN 13164
Rigid polyurethane foam and polyisocyanurate	BS EN 13165
Phenolic foam	BS EN 13166
Cellular glass	BS EN 13167
Other materials	Technical Requirement R3

Reference should be made to BRE document BR135 — Fire performance of external thermal insulation for walls of multi-storey buildings: (BRE135) Third edition.

Rainscreen cladding

The backing wall should be adequately insulated, particularly at exposed areas. Where open joints are used, a continuous and durable breather membrane should be provided over the outer face of the insulation.

Where the insulation is fixed to the backing wall, a minimum of one non-combustible fixing per 1m² or per insulation batt, whichever is the lesser, should be provided in addition to the other fixings.

Figure 5: Insulated backing wall to rainscreen cladding

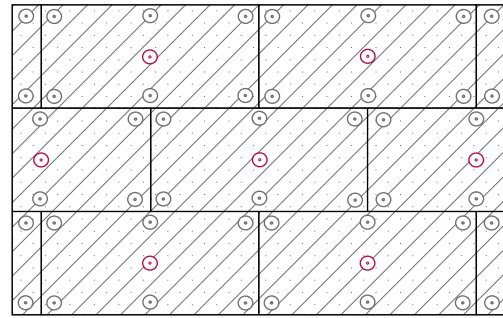
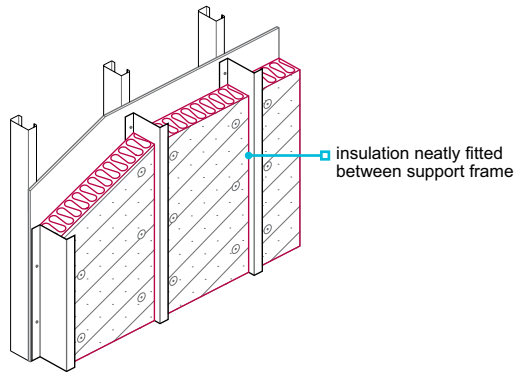

Figure 6: Insulated render with drained cavity

Insulated render

A minimum of one non-combustible fixing per 1m² or per insulation batt, whichever provides the greater number, should be provided in addition to the other fixings.

Non-combustible fixings should be fixed through the mesh reinforcement.

Insulation should be suitable to receive the render finish, and keyed where appropriate.

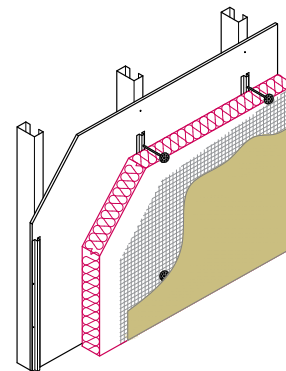
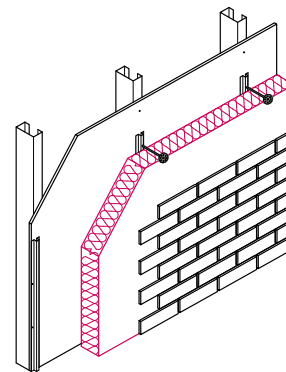

Figure 7: Brick slip cladding with drained cavity

Brick slip cladding

Where the insulation is fixed to the backing wall, a minimum of one non-combustible fixing per 1m² or per insulation batt, whichever is the lesser, should be provided in addition to the other fixings.

**6.9.9 Damp proofing and vapour control**

Curtain walling and cladding systems, including damp proofing materials and breather membranes, shall adequately resist the passage of water into the building and allow water vapour to pass outwards.

Damp proofing should:

- be installed correctly to provide a physical barrier to the passage of water, and to ensure water is directed to the outside
- include cavity trays with stop ends at the base of the system, above openings, above cavity barriers, interfaces and other interruptions to the cavity where necessary
- use DPCs/DPMs where necessary, including the junction between the system and any other component or systems
- use only appropriate tapes and sealant (but not solely rely on sealant) in accordance with the design and the manufacturer's recommendations.

For curtain walling systems, the DPC/DPM should extend the full height of the system and have appropriate details at each interface (including floors, walls, roofs, balconies and terraces).

DPCs/DPMs and flexible cavity trays

Damp proofing should be:

- formed from materials which are compatible with adjoining components
- the correct dimensions to suit the detailed design
- constructed from preformed components at complicated junctions.

The following materials are acceptable for use as DPCs/DPMs:

- BS 6515 polyethylene
- EPDM
- neoprene
- materials assessed in accordance with Technical Requirement R3.

Flashings

The following materials are acceptable as flashings:

- BS EN 12588 rolled lead sheet (minimum Code 4)
- BS EN 485 and BS EN 573 aluminium and aluminium alloys
- BS EN 988 zinc alloys
- stainless steel.

Breather membranes

Breather membranes should:

- comply with BS EN 13859-2: 2014 (Type 1 in areas of very severe exposure), or
- be in accordance with Technical Requirement R3.

6.9.10 Installation and tolerances

Also see: Chapter 9.1

Curtain walling and cladding systems shall:

- 1) be installed by competent operatives
- 2) be installed to achieve design tolerances and established standards.

6.9.10.1 Installation

Systems should be installed by operatives who:

- are competent
- are familiar with the system being installed
- hold a certificate confirming that they have been trained by the system manufacturer, supplier or installer.

6.9.10.2 Tolerances

Systems should be completed, within reasonable tolerances, in accordance with the design, and allowing for the line, level, plumb and plane of the completed wall to be within reasonable tolerances for the materials involved.

6.9.11 Electrical continuity and earth bonding

Curtain walling and cladding systems shall ensure electrical continuity and earth bonding.

Curtain walling and rainscreen cladding should comply with:

Table 2: Standards for Electrical continuity and earth bonding systems

BS 7671	Requirements for Electrical Installations. IET Wiring Regulations
BS EN 62305	Protection against lightning
BS EN 62305-3	Protection against lightning — Physical damage to structures and life hazard

6.9.12 Maintenance

Curtain walling and cladding systems shall have appropriate access arrangements for the purposes of cleaning, inspection, maintenance and repair.

Provision should be made for safe future access to the façade. Access should generally be provided from a safe working platform, such as a cradle or mobile elevating platform.

Appropriate arrangements should be made for the replacement of failed insulating glass units without incurring excessive costs for gaining access.

6.9.13 Glazing, gaskets and sealants

Glazing shall be carried out in accordance with relevant standards. Materials used for glazing, gaskets and sealants shall provide satisfactory performance.

Glazing, including insulating glass units, should be in accordance with Chapter 6.7 Doors, windows and glazing. Extruded rubber gaskets should comply with BS 4255 or assessed in accordance with Technical Requirement R3.

Sealant and tapes should be selected and applied in accordance with:

- BS 6213
- BS EN ISO 11600.

Sealant used in locations where differential movement may be expected, eg interfaces between the façade and the structure, should be one of the following:

- one or two part polysulphide
- one or two part polyurethane
- one part silicone
- materials assessed in accordance with Technical Requirement R3.

6.9.14 Cavity barriers and firestops

Materials used for cavity barriers and firestops shall be capable of producing adequate resistance to fire and smoke.

Materials are acceptable where they are:

- specified in Building Regulations
- assessed in accordance with Technical Requirement R3.

Systems incorporating proprietary intumescent materials should follow the guidance provided by:

- the Intumescent Fire Seals Association (IFSA)
- the Association for Specialist Fire Protection (ASFP).

6.9.15 Ventilation screens

Ventilation openings shall be protected from the entry of birds and animals.

Where openings are larger than 10mm, a screen to prevent birds and animals entering the cavity should be provided:

- in accordance with the design
- at penetrations through the cladding.
- at the top and bottom of the rainscreen

6.9.16 Handling and storage

Materials, products and systems shall be protected and stored in a satisfactory manner to prevent damage, distortion, uneven weathering and degradation.

The handling and storage of curtain walling or cladding system should ensure:

- components are transported, lifted, handled and stored in accordance with the manufacturer's recommendations
- insulated glass units are carefully stored and protected in a sheltered dry area.

Practical steps should be taken to avoid the risk of damage to the curtain walling or cladding system during construction.

6.9.17 Curtain walling

Curtain walling shall ensure adequate in-service performance. Issues to be taken into account include:

- | | |
|--------------------------------------|-----------------------------|
| 1) acoustic performance | 5) opening doors and lights |
| 2) weather resistance | 6) off-site testing |
| 3) thermal bridging and condensation | 7) site testing. |
| 4) air infiltration | |

6.9.17.1 Acoustic performance

Noise from the curtain walling system caused by loads, movements and changes in the environmental conditions should be accommodated without being intrusive.

The curtain walling system should be designed to resist the passage of airborne and impact sound within the building. To reduce flanking transmission, precautions may be required at the:

- edges of separating floors
- outer ends of separating walls
- outer ends of partition walls
- junctions with roof constructions and parapets.

6.9.17.2 Weather resistance

Curtain walling systems should have:

- external and internal air and water seals, with a drained and ventilated cavity at each interface
- drained and ventilated glazing rebates, including gaskets and seals.

The following figures show typical interfaces and general design principles:

Figure 8: Curtain walling to insulated render system — horizontal section

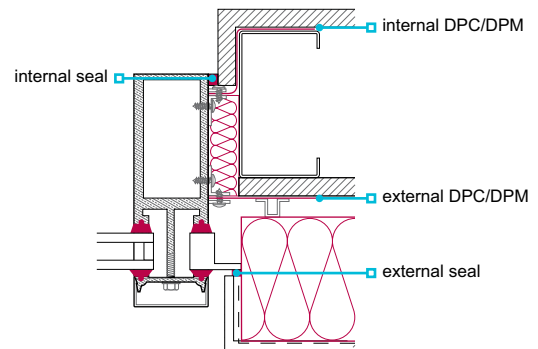

Figure 9: Curtain walling to balcony/terrace: vertical section

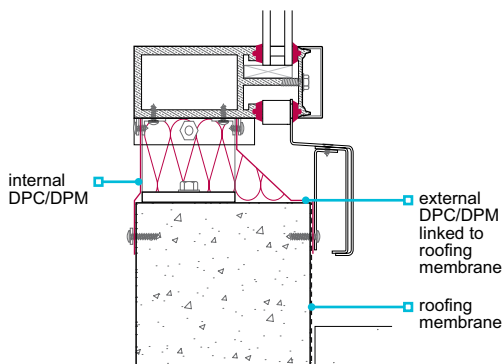

Figure 10: Curtain walling to conventional brick and block wall: horizontal section

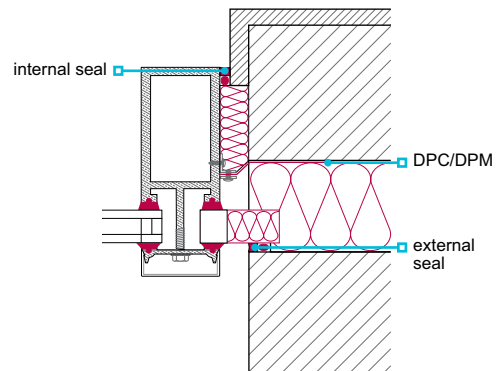

Figure 11: Curtain walling to soffit: vertical section

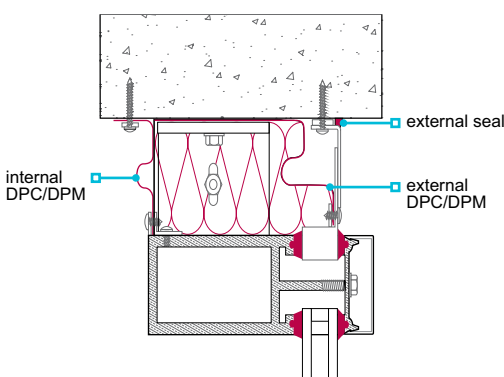
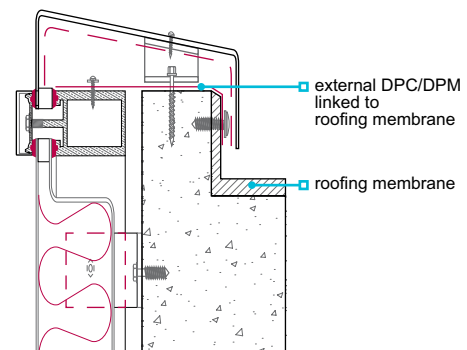

Figure 12: Curtain walling to roof, including coping detail: vertical section



6.9.17.3 Thermal bridging and condensation

The design and construction of curtain walls should:

- ensure interfaces are adequately insulated and installed in accordance with the design
- minimise the risk of surface and interstitial condensation by providing thermal breaks and a continuous, durable VCL, in accordance with the design
- ensure thermal bridging is controlled so that no part of the curtain wall is more at risk from surface condensation than the glazing.

6.9.17.4 Air infiltration

Curtain walling systems should be sealed with preformed factory-moulded 'picture frame' type vulcanised EPDM or silicone internal gaskets. Gaskets and sealants should:

- be used to resist the flow of air from the outside to the interior surface of the curtain walling system
- comply with BS 6213 and be used in accordance with manufacturers' recommendations.

Particular attention should be given to the interfaces between the curtain walling system and the walls, roof, doors, windows and cladding system.

Figure 13: Frame perimeter weathersealing gasket

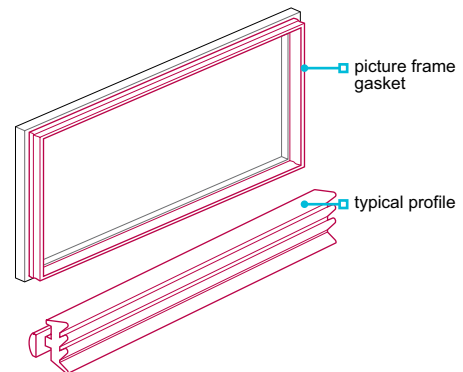

6.9.17.5 Opening doors and lights

Opening doors and lights should:

- hang square within the curtain wall frame
- fit neatly and with minimal gaps to ensure effective weatherproofing.

6.9.17.6 Off-site testing

Air and water testing of the 'prototype' curtain walling system should be carried out in accordance with, and pass, the CWCT Standard test sequence (A or B) up to a maximum test pressure of 600 pascals. Panels tested should be of a similar size and configuration to those to be used on the building.

Where the maximum calculated design wind pressure is above 2.4 kPa, the test pressure should be increased to 0.25 x the design wind pressure.

The prototype should remain watertight during and after the test.

At a test pressure of 600 pascals, an air infiltration rate no higher than 1.5m³/hr/m² for fixed glazed panels is permissible, provided there is no evidence of concentrated leakage.

Wind resistance, serviceability and safety testing should be carried out in accordance with the CWCT Standard.

6.9.17.7 Site testing

Site testing should:

- be conducted to determine resistance to water penetration, including joints and interfaces which are intended to be permanently closed and watertight
- ensure a representative sample of the finished installation is hose tested in accordance with the current CWCT Standard for curtain walling
- ensure a minimum of 5% of the completed curtain walling system is tested, especially in vulnerable areas such as joints and interfaces.

Other testing may be acceptable where it is considered to be a suitable alternative by NHBC.

The results of the test should be made available to NHBC.

6.9.18 Rainscreen cladding

Rainscreen cladding systems shall ensure adequate in-service performance. Issues to be taken into account include:

- | | |
|--------------------------------------|---------------------|
| 1) acoustic performance | 5) compartmentation |
| 2) weather resistance | 6) certification |
| 3) thermal bridging and condensation | 7) site testing. |
| 4) air infiltration | |

6.9.18.1 Acoustic performance

Noise from the rainscreen cladding system caused by rain striking the outer surface of panels should be accommodated without being intrusive through the use of material that is:

- noise absorbing, or
- anti-drumming.

6.9.18.2 Weather resistance

To ensure moisture is directed to the outside, DPC/DPM arrangements should be correctly formed with suitable upstands and stop ends, including at the junction between the rainscreen cladding and any other component or system. External and internal air and water seals and a drained cavity should be provided at all interfaces.

The air gap between the face of the insulation and the back of the panels should be of sufficient width and have suitably sized drainage, allowing any water passing the joints to:

- run down the back of the rainscreen panels
- be discharged externally without wetting the insulation or the backing wall.

Free drainage

Air gaps should be adequately ventilated and the following minimum widths maintained behind all rainscreen panels:

- 50mm for panels with open joints, or
- 38mm for panels with baffled or labyrinth (rebated) joints.

Open, baffled or labyrinth (rebated) joints should have a minimum 10mm opening, unless specified otherwise.

Figure 14: Cladding panel joint types and spacings

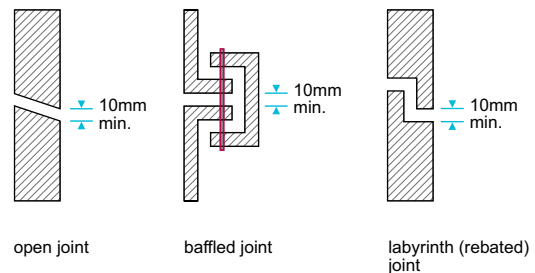

6.9.18.3 Thermal bridging and condensation

The system should:

- be designed to minimise the risk of thermal bridging, surface and interstitial condensation
- be assessed using a BS 5250 condensation risk analysis
- generally include a vapour control layer fixed to the warm side of the wall insulation.

6.9.18.4 Air infiltration

Before installation of the system, the backing wall should be reasonably airtight with:

- masonry walls jointed to a high standard ie, each joint filled
- framed walls, including a rigid sheathing on the cavity face, with each joint taped or sealed.

Where reasonable airtightness cannot be achieved:

- a separate continuous vapour permeable air barrier should be provided on the outer face of the backing wall
- joints should be taped or sealed.

6.9.18.5 Compartmentation

Rainscreen cladding systems that have open joints between the panels should be designed to be pressure equalised. The cavity should be compartmented by:

- a horizontal cavity closer at each floor level
- vertical cavity closers at centres not exceeding 6m
- vertical cavity closers at centres not exceeding 1.5m within 6m of an internal or external corner
- a vertical cavity closer as close as possible to an external corner, generally within 300mm.

Figure 15: Compartmentation to achieve pressure equalisation

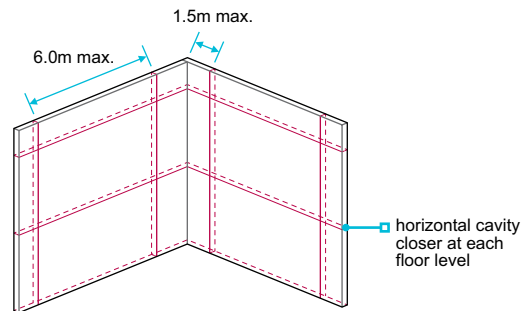

The NHBC Technical Requirements for rainscreen wall cavity compartmentation are in addition to Building Regulations (to control the spread of smoke and fire), but may be used for the same purpose.

Cavity closers should:

- be rigid and installed in accordance with the manufacturer's recommendations
- enable ventilation and drainage to be maintained in accordance with the design.

6.9.18.6 Certification

Rainscreen cladding systems, including panels, should have current certification confirming satisfactory assessment by an appropriate independent technical approvals authority accepted by NHBC.

6.9.18.7 Site testing

On-site hose or sparge bar testing should be carried out with emphasis on interfaces that are designed to be permanently closed and watertight.

The building should remain watertight during and after the test.

6.9.19 Insulated render and brick slip cladding

Also see: Chapter 6.2

Insulated render and brick slip cladding shall be designed and installed to ensure adequate in-service performance. Issues to be taken into account include:

- 1) weather resistance
- 2) thermal bridging and condensation
- 3) air infiltration
- 4) insulated render: reinforcement and render
- 5) brick slip cladding: slips, carriers and joints.

6.9.19.1 Weather resistance

Timber and steel framed backing walls should have a cavity between the wall and the insulation which is:

- a minimum of 15mm wide
- drained and vented (for timber frame)
- drained (for steel frame).

A cavity can increase the risk of damage from impact, especially at low level, around balconies and where cradle systems, etc can come into contact with the façade. Suitable precautions to resist impact damage should be provided eg by the provision of a rigid board behind the insulation whilst maintaining the cavity.

Figure 16: Insulated render system to timber frame or light steel frame wall

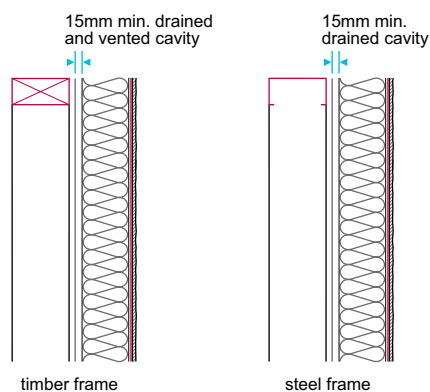

The following figures show typical interfaces and general design principles:

Figure 17: Insulated render system to windows and doors: horizontal section

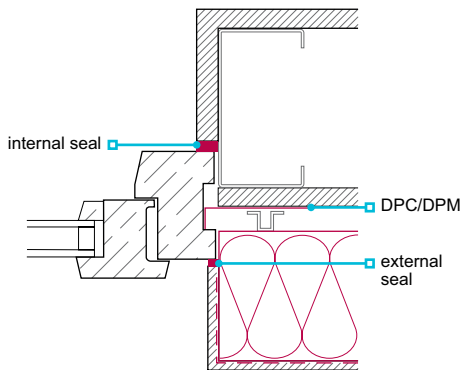

Figure 18: Penetration of gas flue through insulated render system on light steel frame: horizontal section

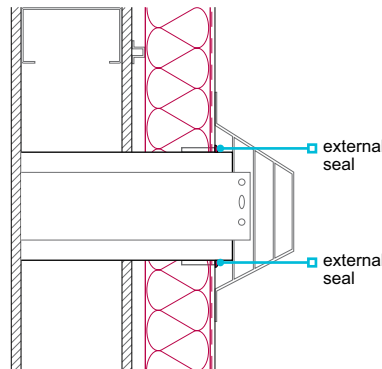
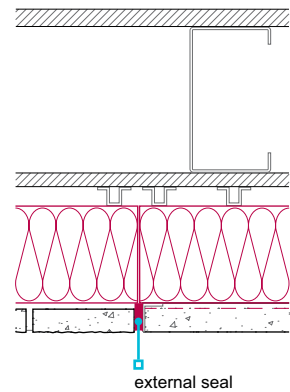

Figure 19: Brick slip cladding to insulated render system: horizontal section



Movement joints in the backing wall should be:

- continued through the insulated render system
- formed in accordance with the manufacturer's recommendations.

6.9.19.2 Thermal bridging and condensation

The system should:

- be designed to minimise the risk of thermal bridging and condensation
- be assessed using suitably accredited ie, IS 9001 condensation risk analysis
- generally include a VCL, fixed to the warm side of the wall insulation.

6.9.19.3 Air infiltration

Before installation of the system, the backing wall should be reasonably airtight with:

- masonry walls jointed to a high standard ie, each joint filled
- each joint taped or sealed on framed walls, including a rigid sheathing on the cavity face.

6.9.19.4 Insulated render: reinforcement and render

Reinforcement should:

- be detailed in the design and be in accordance with the manufacturer's recommendations
- be formed with appropriate trim at openings, corners, angles, interfaces and movement joints
- include additional mesh where there may be increased stress in the render system ie, at the corners of window or door openings
- be lapped to a minimum of 100mm.

Figure 20: Reinforcement mesh bonded to blockwork

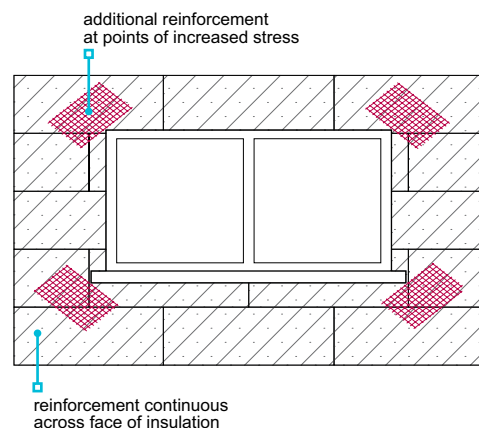

Render should:

- not be applied where the surface has contamination, dust or loose particles
- have the appropriate number and thickness of coats in accordance with the manufacturer's recommendations
- be mixed to ensure colour consistency where coloured pigments are specified
- be specified and used with the appropriate trims to form corners, returns and features in accordance with the manufacturer's recommendations.

6.9.19.5 Brick slip cladding: slips, carriers and joints

Brick slip systems, including proprietary carriers forming an integral part of the system, should:

- be specified and fixed in accordance with the design and the manufacturer's recommendations, taking account of relevant height restrictions
- be set out and designed to ensure that excessive cutting of brick slips is avoided ie, in the storey heights, at corners and around openings
- have coursing arranged to suit lintel heights.

Mortars, proprietary mortars and grouts should be specified:

- to enable each joint to be adequately filled and appropriately struck
- in accordance with the system manufacturer's recommendations.

Figure 21: Setting out of insulation layer and brick slip carrier system

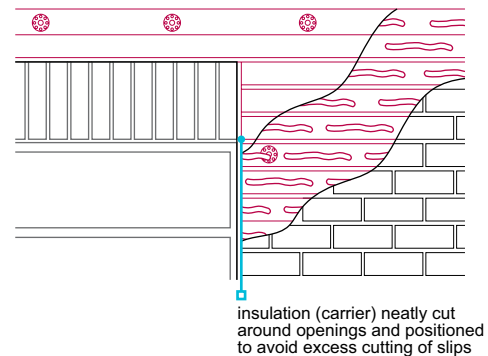

6.9.20 Further Information

- *BS EN 1991-1-1 Eurocode 1 Actions on structures General actions — Densities, self-weight, imposed loads for buildings*
- *BS EN 1991-1-4 Eurocode 1 Actions on structures — General actions — Wind actions*
- *BS EN ISO 3506-1 Mechanical properties of corrosion-resistant stainless-steel fasteners. Bolts, screws and studs with specified grades and property classes*
- *BS EN ISO 2081:2008 Metallic and other inorganic coatings — Electroplated coatings of zinc with supplementary treatments on iron or steel*
- *BS EN ISO 1461 Hot dip galvanized coatings on fabricated iron and steel articles. Specifications and test methods*
- *BS EN ISO 12944 — Paints and varnishes. Corrosion protection of steel structures by protective paint systems*
- *ISO 14713-1:2017 Zinc coatings — Guidelines and recommendations for the protection against corrosion of iron and steel in structures Part 1: General principles of design and corrosion resistance*
- *BS EN 573-1 Aluminium and Aluminium alloys — Chemical composition and form of wrought products Part 1: Numerical designation system Nov-2004*
- *BS EN 573-2 Aluminium and Aluminium Alloys — Chemical composition and form of wrought products Part 2: Chemical Symbol Designation System Jan-1995*
- *BS EN 573-3 — Aluminium and aluminium alloys — Chemical composition and form of wrought products — Part 3: Chemical composition / form of products Aug-2019*
- *BS EN 772 — Methods of Test for Masonry Units Multi-part Document divided into Parts 1 — 22*
- *BS EN 755 — Aluminium and aluminium alloys. Extruded rod/bar, tube and profiles Multi-part Document divided into Parts 1 — 9 refer to parts 1 and 2:*
- *BS EN 755 Part 1 Aluminium and aluminium alloys. Extruded rod/bar, tube and profiles. Technical conditions for inspection and delivery*
- *BS EN 755 Part 2 Aluminium and aluminium alloys. Extruded rod/bar, tube and profiles. Mechanical properties*
- *BS 5080 Part 1 Methods of test for structural fixings in concrete and masonry. Tensile loading*
- *BS 5080 Part 2 Structural fixings in concrete and masonry. Method for determination of resistance to loading in shear*
- *BS EN 13162 Thermal insulation products for buildings. Factory made Mineral Wool (MW) products*
- *BS EN 13163 Thermal insulation products for buildings — Factory made Expanded Polystyrene (EPS) products — Specification (FR grade (flame retardant) expanded polystyrene)*
- *BS EN 13164: 2012(+A1:2015) Thermal insulation products for buildings. Factory made Extruded Polystyrene foam (XPS) products. Specification (FR grade (flame retardant) extruded polystyrene)*
- *BS EN 13165: 2012(+A2:2016) Thermal insulation products for buildings. Factory made rigid Polyurethane foam (PU) products. Specification (Rigid polyurethane foam and polyisocyanurate)*
- *BS EN 13166 Thermal insulation products for buildings — Factory made Phenolic Foam (PF) products — Specification (Phenolic foam)*
- *BS EN 13167 Thermal insulation products for buildings — Factory made Cellular Glass (CG) products — Specification (Cellular glass)*
- *BR135 Fire performance of external thermal insulation for walls and multi-storey buildings 3rd Edition BRE 2013*
- *BS EN 12588 Lead and Lead Alloys — Rolled Lead Sheet for Building Purposes (minimum Code 4)*
- *BS EN 485 and BS EN 573 aluminium and aluminium alloys multi-part document divided into the following 2 parts:*
- *BS EN 485-1: 2016 Aluminium and aluminium alloys — Sheet, strip and plate — Part 1: Technical conditions for inspection and delivery*
- *BS EN 485-2: 2016 (+A1:2018) Aluminium and aluminium alloys. Sheet, strip and plate — Part 2: Mechanical properties*

- *BS EN 573 Multi-Part document divided into the following parts:*
- *BS EN 573-1 Aluminium and aluminium alloys. Chemical composition and form of wrought products. Part 1: Numerical designation system*
- *BS EN 573-2 Aluminium and aluminium alloys. Chemical composition and form of wrought products. Part 2: Chemical symbol-based designation system*
- *BS EN 573-3 Aluminium and aluminium alloys. Chemical composition and form of wrought products. Part 3: Chemical composition and form of products*
- *BS EN 573-4 Aluminium and aluminium alloys. Chemical composition and form of wrought products. Part 4: Forms of products*
- *BS EN 573-5 Aluminium and aluminium alloys. Chemical composition and form of wrought products. Part 5: Codification of standardised wrought products*
- *BS EN 988 Zinc and zinc alloys. Specification for rolled flat products for building*
- *BS EN 13859-2: 2014 Flexible sheets for waterproofing. Definitions and characteristics of underlays. Underlays for walls*
- *BS EN 7671 IET Wiring Regulations Requirements for Electrical Installations, formally 'IEE Wiring Regulations*
- *BS EN 62305-1 — Protection against lightning Part 1 Protection against lightning. General principles*
- *BS EN 62305-2 — Protection against lightning Part 2 Protection against lightning. Risk management*
- *BS EN 62305-3 — Protection against lightning Part 3 Protection against lightning. Physical damage to structures and life hazard*
- *BS EN 62305-4 — Protection against lightning Part 4 Protection against lightning. Electrical and electronic systems within structures*
- *BS 4255-1 Rubber Used in Preformed Gaskets for Weather Exclusion from Buildings — Part 1: Specification for non-cellular gaskets (Active, Most Current Publication Date:30-May-1986)*
- *BS 6213 Selection of construction sealants — Guide*
- *BS EN ISO 11600_2002 Building Construction Jointing products — Classification and requirements for sealants*
- *BS 5250:2011(+A1:2016) Code of practice for control of condensation in buildings*

Light steel framed walls and floors

This chapter gives guidance on meeting the Technical Requirements for light steel framed walls and floors and:

- applies specifically to 'warm frame' and 'hybrid construction' using 0.45-4.0mm thick framing
- does not apply to light steel framed walls used in basements.

6.10.1	Compliance	02
6.10.2	Provision of information	02
6.10.3	Structural certification	03
6.10.4	Structural design of load-bearing floors and walls	04
6.10.5	Structural design of infill walls	07
6.10.6	Roofs	07
6.10.7	Steel and fixings	07
6.10.8	Detailing of steel joists	09
6.10.9	Restraint	10
6.10.10	Construction of load-bearing walls and external infill walls	10
6.10.11	Interfaces with staircases	11
6.10.12	Fixing floor decking and ceilings	12
6.10.13	Other design issues	12
6.10.14	Behaviour in relation to fire	13
6.10.15	Acoustic performance	13
6.10.16	Moisture control	13
6.10.17	Insulation	14
6.10.18	Air and vapour control layers	15
6.10.19	Breather membranes	15
6.10.20	Cladding, lining and sheathing boards	16
6.10.21	Wall ties	17
6.10.22	Services	18
6.10.23	Further information	18

Figure reference table

Figure Reference Table 6.10

Fig No	Title/Description	Clause	Page
Figure 1	Joist bearing onto structure with stiffener	6.10.4.1	4
Figure 2	Web cleat connection	6.10.4.1	4
Figure 3	Bolted web to web connection	6.10.4.1	4
Figure 4	Lintel arrangement	6.10.4.2	6
Figure 5	Holes and notches	6.10.7.4	8
Figure 6	Web stiffeners for continuous joists over load-bearing intermediate wall	6.10.8.1	9
Figure 7	Joists overlapping on load-bearing intermediate wall	6.10.8.1	9
Figure 8	Floor bracing examples	6.10.8.2	9
Figure 9	Floor edges	6.10.10.1	10
Figure 10	Correct positioning	6.10.10.1	11
Figure 11	Strap anchor example	6.10.10.2	11
Figure 12	Bolt-down anchor example	6.10.10.2	11
Figure 13	Ground level interface	6.10.16.2	14
Figure 14	Allowing for differential movement	6.10.20.1	16
Figure 15	Providing wall ties	6.10.21	17

Definitions for this chapter

Differential movement	Movement between the frame and cladding, eg due to thermal expansion, shrinkage (in concrete masonry) and moisture expansion (in clay masonry).
External infill	Walls which are built between the floors of steel or concrete frames and are designed to resist wind loading and to support the weight of the other wall components. They do not provide stability to the building or resist floor loading. External infill is considered as a secondary structural component.
Hybrid construction	Cavity construction where insulation is installed both between the studs and on the cavity side of the steel frame.
LSF	Light steel frame. In this chapter, 'LSF' refers to construction framing members made from cold-formed profiles 0.45-4.0mm thick. Structural members are typically at least 1.0mm thick.
Primary structural components	Elements of the structure designed to carry and transfer primary loads of the building as a whole, including self-weight, dead loads and live loads.
Secondary structural components	Elements of the structure which do not play a wider role in the structure, but carry loads directly imposed on them (and transfer them to the primary structure) such as self-weight, wind loads, cladding and openings.
Sheathing	Board applied to the outside of the steel frame (installed where required by the design).
Warm frame	Cavity construction where insulation is installed on the cavity side of the steel frame.

6.10.1 Compliance

Also see: Chapter 2.1

LSF structures shall comply with the Technical Requirements.

LSF structures (ie, walls, roofs and floors) that comply with the guidance in this chapter will generally be acceptable.

LSF structures may be:

- structurally independent (primary) and used to form whole buildings, additional storeys, annexes, extensions, penthouses, etc
- infill walls (secondary), or
- bespoke facades (where support may be required from other structural elements).

Construction should be 'warm frame' or 'hybrid' construction, with sufficient insulation outside the steel envelope to ensure that condensation does not occur within the depth of the light steel members.

Stud partitions are considered in Chapter 6.3 Internal walls. LSF systems that do not comply with the principles of this chapter should be assessed in accordance with Technical Requirement R3.

Where the components of the LSF cannot be inspected on site (eg closed panels or fitted out volumetric or modular units) the system should be treated as a proprietary building system under Technical Requirement R3 and subject to assessment by an appropriate independent technical approvals authority or be assessed under the NHBC Accepts service - see www.nhbc.co.uk/accepts.

6.10.2 Provision of information

Designs and specifications shall be produced in a clearly understandable format, include all relevant information and be distributed to all appropriate personnel.

Clear and fully detailed drawings should be available on site to enable work to be carried out in accordance with the design. Designs and specifications should be issued to site supervisors, relevant specialist subcontractors and suppliers, and include:

- a full set of drawings and material specifications
- a typical wall build-up, including wall ties, breather membranes, sheathing and vapour control layers, where applicable
- fixing schedules and details of each connection that is to be made on site
- details of connections with other building elements, including roofs, floors and openings
- information on integration of services and work of subsequent trades
- positions and materials for fire stops and cavity barriers in accordance with relevant Building Regulations
- the number and spacing of bolts, screws and rivets
- the manufacturer's recommendations relating to proprietary items
- details of how wall panels are to be fixed to the substructure, adjacent panels, and floor and roof framing
- the specification for each type of fixing, including corrosion protection.

6.10.3 Structural certificationContact us: technical@nhbc.co.uk

The LSF system shall be adequately tested and certified. The design of superstructures with primary structural components formed from LSF shall be checked by an NHBC registered LSF certifier.

Primary structural components formed from LSF require two-stage certification confirming that both the system and the project have been checked. External infill does not require Stage 1 and 2 certification (see Clause 6.10.5).

Stage 1 — system certification

NHBC requires manufacturers of LSF systems, which form primary structural components, to submit a system manual to the Steel Construction Institute (SCI) for assessment. The manufacturer is the company which assembles the steel frame sections to form the wall and/or floor panels. If in doubt, consult NHBC Standards, Innovation and Research.

The manual should contain the information described in Table 1. Further performance issues may be considered at the discretion of SCI and the manufacturer (see Table 7).

Table 1: Items included in the system manual

Topic	Description
Description of system	<ul style="list-style-type: none"> • key features
Application	<ul style="list-style-type: none"> • usage, eg maximum number of storeys and type of cladding
Durability	<ul style="list-style-type: none"> • demonstrate that design life is at least 60 years (including environment category) • grade of steel • corrosion protection • supplementary protection
Strength and stability	<ul style="list-style-type: none"> • structural design philosophy (including codes of practice referenced and test reports) • grade of steel (traceability) • section properties • loading • ultimate limit state • serviceability limit state • resistance to overturning • racking resistance • holding down • connections within the system • connections with other building elements • structural integrity • positions and sizes of holes through members
Additional checks where LSF is used in volumetric construction	<ul style="list-style-type: none"> • module-to-module connections (strength as well as accuracy) • module-to-foundation connections • rigidity in transportation • lifting

Where there are various configurations (eg types of claddings), the manufacturer will need to specify which options SCI is to consider in its assessment. Upon satisfactory completion, SCI will approve the manufacturer's system manual and issue a numbered 'system certificate' which includes:

- a detailed description of the system
- details of usage limitations
- information for reference by the designer and LSF project certifier.

Stage 2 — project certification

The design of all primary structural components should be subject to a Stage 2 certification check by an NHBC registered LSF certifier.

The LSF certifier should:

- be listed on NHBC’s list of LSF certifiers
- be a suitably qualified and experienced civil or structural engineer with appropriate professional indemnity insurance
- not be the designer of the LSF or be employed by the same practice
- check supporting details and calculations
- ensure the Stage 1 system certificate is valid and current
- ensure that the proposals are in accordance with the manufacturer’s Stage 1 system certificate (issued by SCI) and this chapter
- provide confirmation that the requirements have been satisfied for the project
- provide the registered builder with the completed and signed project certificate confirming assessment of structural adequacy for each specific project.

The registered builder should ensure that the completed Stage 2 certificate is available on site for inspection by NHBC.

Contact NHBC Standards, Innovation and Research via OperationsSupport@nhbc.co.uk:

- if you require contact details of frame certifiers, or
- to apply to become an LSF certifier.

6.10.4 Structural design of load-bearing floors and walls

LSF floors and walls shall be designed to support and transfer loads safely and without undue movement.

Issues to be taken into account include:

- 1) structural floors
- 2) structural walls
- 3) overall stability.

6.10.4.1 Structural floors

Floors should:

- be of the correct type
- be fitted in the specified location
- have suitably sized trimmers around floor openings
- have a typical maximum joist spacing of 600mm, although greater spacings may be applied when designed by an engineer in accordance with Technical Requirement R5 or covered by an SCI system-specific Stage 1 assessment with the project-specific application reviewed and checked by an NHBC registered LSF certifier.

Light steel joists should be fixed to supporting walls by either:

- web cleats
- ‘Z’ or ‘L’ hangers
- a track connection
- direct attachment to wall studs, or
- bearing onto the supporting structure (bearing stiffeners may be required).

Joist support cleats should:

- be of the correct type
- be fitted in the specified location
- use fixings as specified in the design.

Where required, web stiffeners should be properly fitted.

Where joists are fitted directly to light steel wall studs, pre-drilled holes should be correctly aligned before making the final connection.

Fixing holes should not be enlarged, and additional holes should not be cut without prior approval of the designer.

Figure 1: Joist bearing onto structure with stiffener

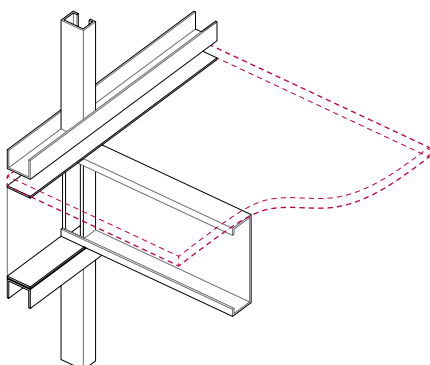

Figure 2: Web cleat connection

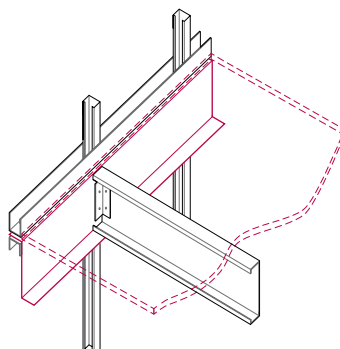
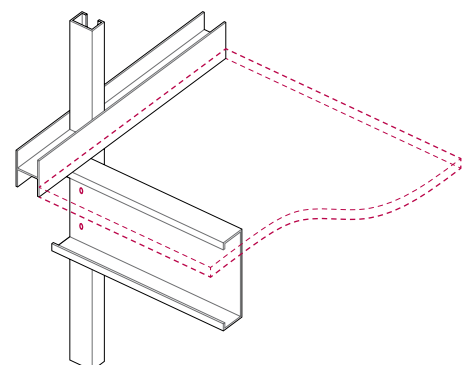

Figure 3: Bolted web to web connection



Static criteria for the maximum permissible deflection of a single joist due to:

- imposed load, limited to (span/450)
- dead and imposed loads, limited to the lesser of (span/350) or 15mm.

Dynamic criteria:

- the natural frequency of the floor should not be less than 8Hz for dead load plus 0.2 x imposed load; this can be achieved by limiting the deflection of a single joist to 5mm for the given loading
- the deflection of the floor (ie, a series of joists plus the floor decking) when subject to a 1kN point load should be limited to the values in Table 2.

Table 2: Deflection with point loads of 1kN

Span (m)	Maximum deflection (mm)
3.5	1.7
3.8	1.6
4.2	1.5
4.6	1.4
5.3	1.3
6.2	1.2

The deflection of a single joist is dependent on the:

- overall floor construction
- number of effective joists that are deemed to share the applied 1kN point load (typical values are given in Table 3).

Table 3: Typical values

Floor configuration	Number of effective joists	
	400mm joist centres	600mm joist centres
Chipboard, plywood or oriented strand board	2.5	2.35
Built-up acoustic floor	4	3.5

Light steel ground floor construction

Provision should be made to prevent ground moisture affecting light steel floors. This can be achieved by covering the ground below the floor with either:

- 50mm oversite concrete or 50mm fine aggregate on 1,200 gauge (0.3mm thick) polyethylene membrane laid on 50mm sand blinding, or
- 100mm oversite concrete on a compacted clean, inert hardcore bed. Where necessary, this concrete should be protected against sulfate attack by the use of a lapped polyethylene DPM, not less than 1,200 gauge (0.3mm thick) or 1,000 gauge where assessed in accordance with Technical Requirement R3.

Floors should have a 150mm minimum void below the floor which is ventilated by:

- openings on at least two opposite sides
- 1500mm² per metre run of external wall or 500mm² per m² of floor area (whichever provides the largest area).

Where there is shrinkable soil, heave can occur. The minimum underfloor void ventilation requirement should be increased as follows:

- high potential — 150mm (300mm total)
- medium potential — 100mm (250mm total)
- low potential — 50mm (200mm total).

See Chapter 4.2 Building near trees for definitions of high, medium and low volume change potential.

For concrete ground floors refer to Chapters 5.1 Substructure and ground-bearing floors and 5.2 Suspended ground floors.

Concrete upper floors

Concrete floors may be used with LSF and may be constructed using either thin precast units or in-situ concrete placed on steel decking. The deflection of simply supported composite floors should be limited to take account of the long-term effects of creep and shrinkage. Composite floors should be appropriately propped until the concrete reaches the required strength and should not be overloaded during construction. Guidance can be found in Section 6.3 of SCI publication P402 Light steel framing in residential construction.

6.10.4.2 Structural walls

The structural design of the building should ensure adequate resistance to loadings including dead loads, imposed loads, wind loads and snow loads, in accordance with:

- BS EN 1991-1-1
- BS EN 1991-1-3
- BS EN 1991-1-4.

Provision of support to heavy attachments such as hung boilers or kitchen units may be required. In such cases, additional light steel plates or noggings can be included to improve strength and use of a suitable sheathing board and/or fixing directly to the steel studs by self-drilling self-tapping screws may also be required.

Further guidance on deflection limits can be found in SCI publications P402 Light steel framing in residential construction and P437 Design of stability systems for light steel framing.

Individual studs should generally:

- be sized to meet structural requirements, allowing for board fixings at joints and construction tolerances
- have a maximum spacing of 600mm
- consider deflection if not designed to carry vertical loading from the primary structure.

Alternative stud arrangements should be agreed with NHBC.

Lintels, including trussed lintels, should be:

- provided to any opening in load-bearing panels where one or more studs is cut or displaced to form the opening, but are not required where an opening falls between studs
- securely fixed to supporting studs to ensure that loads are fully transferred.

At openings, additional studs may be required to provide support or fixing points for wall ties, cladding and wall linings.

Multiple studs should be included to support multiple joists, unless otherwise specified by the designer.

Where panels are diagonally braced with a flat strip, the brace should be fixed to each stud at the intersection to minimise bowing in the bracing member. Alternatively, bracing may be tensioned using alternative methods where included in the scope of the Stage 1 certification.

Appropriate holding-down devices should be provided to resist uplift, where necessary. The anchorage for holding-down devices should have sufficient mass to resist the uplift forces (See Clause 6.10.10).

Where roof trusses sit directly on a top track, the design should consider all loads, such as:

- wind uplift
- lateral support
- vertical loading (assuming that trusses may be offset from studs).

Where included in the design, timber wall plates should be:

- fixed to the head rail of wall panels onto which timber roof trusses bear
- sized (including the head rail) to permit single timber trusses to be positioned at any point between studs.

Allowance for movement, including at openings and penetrations, should:

- prevent load transfer onto services or flues
- consider elastic shortening of the LSF and movement potential of any panels, cladding or boards
- be fully co-ordinated with the whole building design.

Figure 4: Lintel arrangement

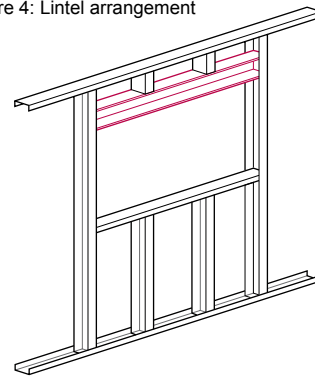

6.10.4.3 Overall stability

Also see: Chapters 7.1 and 7.2

Methods to provide overall stability should either:

- be designed to BS EN 1993-1-1, or
- be tested to BS EN 594.

Wall panels may provide stability using one or more of the following techniques:

- internal bracing
- external sheathing board in accordance with Clause 6.10.20
- crossed flat bracing
- rigid frame action.

Internal lining boards can be used where demonstrated to be suitable for the purpose.

6.10.5 Structural design of infill walls

Infill walls shall be designed to support and transfer loads to the structure safely and without undue distortion or movement.

Infill panels should be designed to resist the expected wind loads, any loads transferred by the cladding system, and those imposed by windows and doors within the panels. Load concentrations resulting from the presence of openings should also be considered. The design should be in accordance with BS EN 1993-1-3. Additional information can be found in SCI publication ED017 Design and installation of light steel external wall systems.

6.10.6 Roofs

Roofs supported by LSF constructions shall be designed to support the roof coverings and transfer loads safely and without undue movement.

Connections between LSF walls and timber or LSF pitched roofs require careful consideration in the design.

LSF pitched or flat roofs should only be used in warm roof or hybrid construction ie, with insulation over rafters (or joists in flat roofs).

Condensation risk should be considered in accordance with BS 5250.

6.10.7 Steel and fixings

Steel and fixings shall be suitable for the intended use. Issues to be taken into account include:

- | | |
|---------------------------------|----------------------------|
| 1) steel grade | 3) connections and fixings |
| 2) protection against corrosion | 4) holes and notches. |

6.10.7.1 Steel grade

Steel should be in accordance with BS EN 10346 and of any of the following grades:

- S280
- S320
- S350
- S390
- S420
- S450.

6.10.7.2 Protection against corrosion

All steel should be pre-galvanised in accordance with BS EN 10346 (minimum 275g/m² zinc coating (Z) or 150g/m² aluminium-zinc alloy coating (AZ)). Structural steel members should not be altered without the approval of the designer. Welded zones should be cleaned and treated with a zinc-rich paint to prevent corrosion.

Where the LSF floor is to be located at 150mm or more above the external ground level, the junction between the ground floor joists and their support should be designed to maintain the durability of the floor. Light steel floor joists and ring beams in such floors should be galvanised to 450g/m².

Alternatively, they can be galvanised to 275g/m² with additional protection of a two-coat bitumen-based coating to BS 1070, BS 3416 or BS 6949, or have a two-coat liquid asphaltic composition applied. Ring beams to ground floors should be totally protected, and joists protected for a minimum of 300mm adjacent to an external wall support or ring beam.

Where steel is used less than 150mm above ground level the guidance in Clause 6.10.16 should be considered.

6.10.7.3 Connections and fixings

Where two metals are to be joined, they should either be:

- compatible and not cause bimetallic corrosion, or
- isolated from each other.

Connections should be:

- properly installed
- justified in accordance with BS EN 1993-1-3 or a test method acceptable to NHBC.
- securely made by clinching, crimping or by one of the methods detailed in Table 4

Table 4: Types of connections

Type of connection	Relevant standard
Cleats	BS EN 1993-1-1
Countersunk bolts (tightened to the correct torque)	BS 4933
Hot-dip galvanised fasteners	BS EN ISO 10684
Rivets, including self-piercing rivets	Manufacturer's recommendations
Screws	BS EN ISO 10666 BS EN ISO 15480 BS EN ISO 15481 BS EN ISO 15482 BS EN ISO 15483 (also see BS EN ISO 4042)
Welded connections	BS EN 1011 and BS EN 1090
Zinc-plated bolts	BS 7371-3

Holding-down devices

Holding-down devices should be suitable for the environment they will be exposed to, and manufactured from:

- mild steel with zinc coating to BS EN ISO 1461
- stainless steel to BS EN 10095 (suitable for most environments).

6.10.7.4 Holes and notches

Joists and studs should not be altered without the approval of the steel frame designer, and the drilling, cutting or punching through of members shall only be undertaken to an engineer's design in accordance with Technical Requirement R5.

To prevent damage to services, holes and penetrations should be fitted with grommets or swaged under factory conditions.

End notching of light steel joists may be required for the interconnection of trimming joists and should be in accordance with the design. Notches elsewhere in the span are not acceptable.

Also see Clause 6.10.22.

Figure 5: Holes and notches

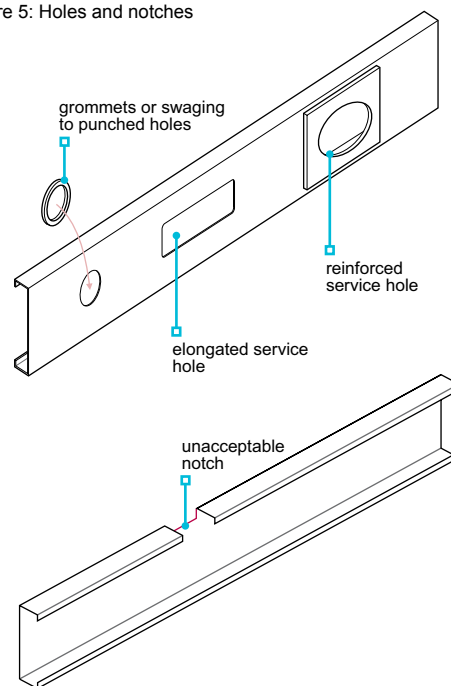

6.10.8 Detailing of steel joists

Steel joists, fixings and connections shall be suitably detailed and provide satisfactory performance. Issues to be taken into account include:

1) installation details

2) prevention of roll.

6.10.8.1 Installation details

Joists or floor beams should be:

- spaced as shown in the design
- accurately cut to length in accordance with the manufacturer's recommendations to ensure a tight fit
- joined with the correct type, size and number of fixings.

Where light steel joists are supported by steel joists, cleats or web stiffeners should be used in accordance with the design.

Joists may be doubled up to support partitions or to form trimmers.

Continuous joists on load-bearing intermediate walls should be reinforced as required by the design.

Figure 6: Web stiffeners for continuous joists over load-bearing intermediate wall

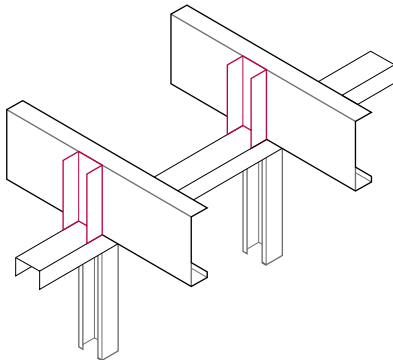
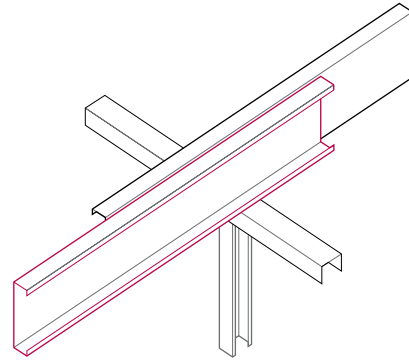

Figure 7: Joists overlapping on load-bearing intermediate wall



Where joists overlap on load-bearing intermediate walls, they should be fixed together with bolts or screws. This is to prevent the floor decking being pushed up, or the ceiling being cracked, when the cantilevered part of the joist moves upwards.

6.10.8.2 Prevention of roll

Bridging and blocking should be provided in accordance with the design to prevent roll.

Floors constructed using joists with an asymmetric web, eg of C or Sigma profile, can cause the floor to roll. To avoid roll, unless otherwise specified in the design, one of the following alternatives should be used where the span exceeds 3.5m for C joists or 4.2m for Sigma joists:

- a continuous line, or lines, of proprietary steel herringbone struts provided between the joists; the pairs of struts should have a physical gap between them so that they do not rub against each other at the cross-over point and create noise
- solid blocking provided to every alternate pair of joists with ties between them as shown
- joists alternately reversed and tied together in pairs
- joists alternately reversed and continuous ties (eg resilient bar) fixed to the joist flanges.

Where joists bear onto steelwork or are supported by cleats, blocking is not necessary adjacent to the supports.

Figure 8: Floor bracing examples

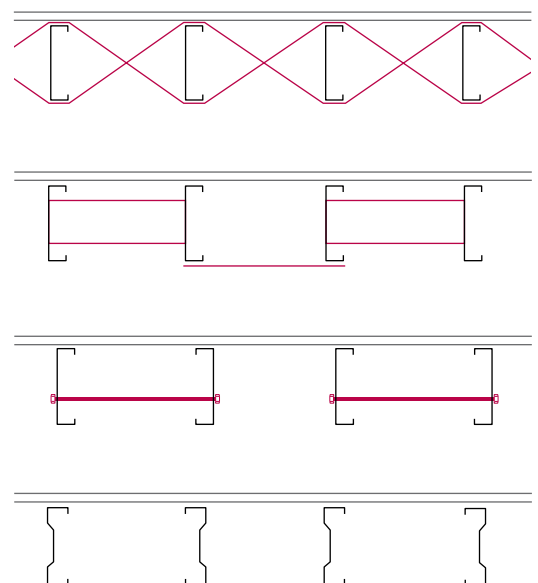

6.10.9 Restraint

Restraint strapping shall be provided in accordance with the design.

Where external walls, not constructed from LSF, are to be stabilised by a connection to the floor, straps may be required. Straps will generally be fixed to the web of the joist, to suit the masonry courses.

Where joists run parallel to the wall, straps should be supported on noggings fixed between the joists. Straps should be placed at a maximum of 2m apart and carried over three joists. Packing should be provided between the wall and the first joist.

Straps should be fixed with suitable bolts, screws or rivets and should bear on the centre of bricks or blocks, not across mortar joints.

6.10.10 Construction of load-bearing walls and external infill walls

Construction of load-bearing walls and external infill walls shall ensure adequate stability. Issues to be taken into account include:

- 1) preparation
- 2) anchoring
- 3) accommodation of deflection.

6.10.10.1 Preparation

The following should be in accordance with the design:

- the setting out of the structure onto which the LSF is to be erected
- the transfer of loads from the LSF.

The supporting structure may have local deviations in level along its length, and packing will be required to achieve the required tolerances and to provide for effective load transfer.

Concrete kickers should be carefully formed, ensuring that the concrete is adequately compacted and the top surface is suitably flat and level.

Figure 9: Floor edges

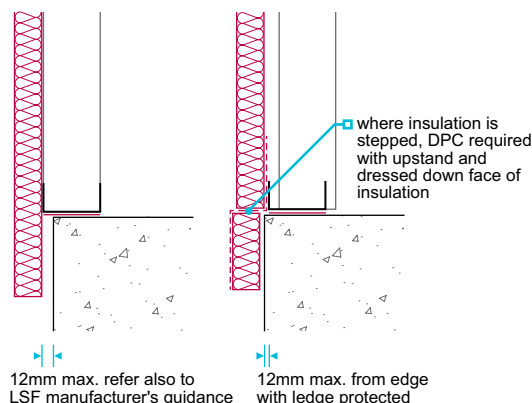

Table 5: Acceptable methods of packing under frames

Gap under base rail	Acceptable packing
Less than 10mm	Provide shims under each stud position
10-20mm	Provide shims under each stud position, and grout under the whole length of the base rail with cement: sand mortar
More than 20mm	Obtain advice from the frame designer/manufacturer Remedial work to the substructure may be required before erection commences

Shims should be of pre-galvanised steel (the galvanised coating being at least equivalent to that of the member/s being packed) or other suitable material, ie, not timber or plastic.

Wall frames should be checked to ensure that they are dimensionally accurate before erection commences.

LSF should be correctly positioned, square and plumb, and within the following tolerances:

- the vertical position of members should be within $\pm 5\text{mm}$ per storey relative to the base
- the horizontal position of base rails should not vary in alignment by more than 5mm in 10m.

Figure 10: Correct positioning

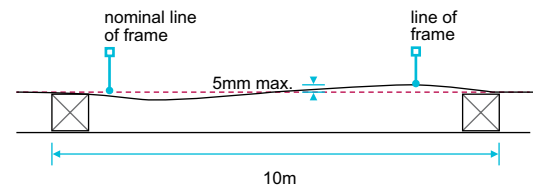

6.10.10.2 Anchoring

The frame should be anchored to resist both lateral movement and uplift in accordance with the design, including bolt-down brackets where required.

Figure 11: Strap anchor example

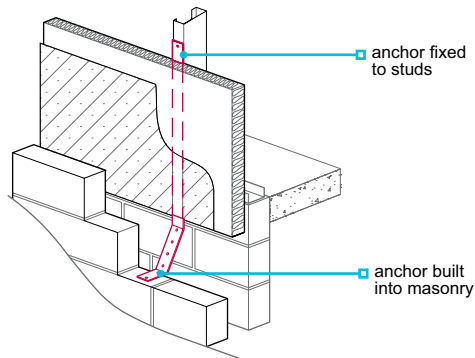
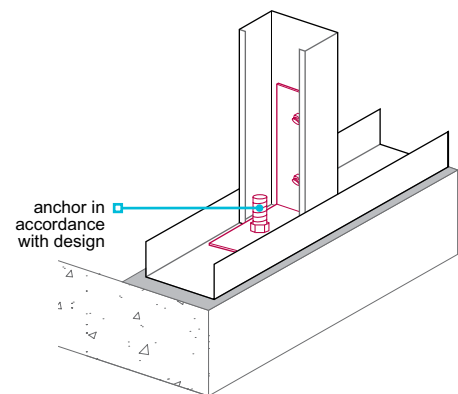

Figure 12: Bolt-down anchor example



Anchoring should ensure:

- that appropriate edge details are provided and minimum edge distances specified by the fixing supplier are maintained, to avoid spalling of masonry or concrete
- where fixings are into masonry, they are into solid concrete blocks with a minimum crushing strength of 7.3N/mm^2 and positioned to receive fixings.

Where the design incorporates gas membranes (methane or radon), fixings should not puncture them, but where this is unavoidable, the penetration should be sealed.

6.10.10.3 Accommodation of deflection

Infill walls should accommodate anticipated deflection within the primary frame in accordance with the structural design.

6.10.11 Interfaces with staircases

Also see: Chapter 6.4

Floors and walls shall be designed to accommodate installation of any staircases without compromising performance.

Wall linings should be continuous behind the string of staircases.

Fixing connections should be co-ordinated to ensure fire protection continuity and structural adequacy.

6.10.12 Fixing floor decking and ceilings

Floor decking and ceilings shall be adequately fixed using a material of adequate strength and moisture resistance.

Joist spacing and decking thickness should be compatible. Material standards and minimum board thicknesses for domestic loads (imposed load of 1.5kN/m²) are shown in Table 6.

Table 6: Joist spacing and decking type

Material	Standard	Minimum thickness of decking (mm)	
		400mm joist centres	600mm joist centres
Chipboard	BS EN 312 moisture-resistant type P5	18	22
Plywood	BS EN 636	15	18
Oriented strand board type OSB3	BS EN 300	15	18
Other materials	In accordance with Technical Requirement R3		

In England and Wales, the thicknesses listed above may not achieve the 15kg/m² mass required to meet sound insulation requirements.

Flooring should be fixed at maximum 300mm centres using self-tapping screws or fixings recommended by the LSF manufacturer and in accordance with Chapter 6.4 Timber and concrete upper floors.

Plasterboard should be fixed in accordance with Chapter 9.2 Wall and ceiling finishes, using self-drilling, self-tapping screws.

6.10.13 Other design issues

The home shall be designed to adequately address all critical performance issues.

The designer should ensure that all critical performance issues listed in Table 7 are appropriately addressed.

Table 7: Critical performance issues requiring the designer's consideration

Topic	Description
Behaviour in relation to fire	<ul style="list-style-type: none"> • compliance with Building Regulations • internal linings • fire stops and cavity barriers • penetrations
Acoustic performance	<ul style="list-style-type: none"> • compliance with Building Regulations
Moisture control, including thermal performance, condensation risk and water ingress	<ul style="list-style-type: none"> • type, thickness and location of insulation material • protection from water ingress at low levels • condensation risk analysis and management of water vapour in the structure
Wall construction	<ul style="list-style-type: none"> • acceptable claddings (see Chapter 6.9 Curtain walling and cladding) • provision of cavity • type of wall ties • sheathing • attachments (eg hung boilers or kitchen units)
Balconies, terraces and parapets	<ul style="list-style-type: none"> • specific design considerations: structural design, durability, weathertightness

Guidance for some of the performance issues listed in Table 7 may be included in the Stage 1 certificate.

6.10.14 Behaviour in relation to fire

LSF walls and floors shall be in accordance with applicable Building Regulations.

Guidance within supporting documents to the Building Regulations should be fully considered in the design and construction of LSF walls, floors and roofs.

Detailing and specification of components should be in accordance with the steel frame manufacturer's recommendations and/or guidance from SCI (see guidance in P424 Light steel framing in fire) and supported with representative test evidence to appropriate standards such as BS 476-21 or BS EN 1365-1 for load-bearing walls, BS 476-22 or BS EN 1364-1 for infill walls and BS EN 1365-2 for floors.

The performance of specific details should be taken into account, including:

- fire protection to the structure around openings
- detailing around service penetrations
- detailing of cavity barriers, including moisture protection to the barrier
- compartmentation including interfaces with fire doors.

6.10.15 Acoustic performance

LSF walls and floors shall have adequate resistance to the passage of sound.

Internal walls and floors should be in accordance with relevant Building Regulations.

Separating walls

Separating walls should be in accordance with the design. Care should be taken to avoid gaps:

- between mineral wool quilt or batts
- between cavity barriers
- between internal lining board layers
- around openings for services.

Separating floors

The floating part of a floor should be separated from the main structure and surrounding walls by a resilient layer. Where boards are laid loose over insulation without battens, joints should be glued.

6.10.16 Moisture control

The structure shall be adequately protected from the effects of moisture. Details for LSF at low level shall fully consider the durability of materials, protection of the building from moisture ingress and thermal bridging. Issues to be taken into account include:

- 1) cavities in external walls
- 2) protection of steel at low level
- 3) DPCs, DPMs and cavity trays.

6.10.16.1 Cavities in external walls

A clear cavity in accordance with Table 8 should be provided between the cladding and insulation.

Table 8: Minimum cavity widths

Cladding	Cavity width
Masonry	50mm
Render on board background	25mm
Vertical tile hanging ⁽¹⁾ where a breather membrane is provided and fixed to the sheathing	Dependent on batten support layout and spacing ⁽¹⁾
Other cladding ⁽¹⁾	15mm

Note

1. See Chapter 6.9 Curtain walling and cladding.

The cavity should:

- extend at least 150mm below the DPC
- be kept clear to allow drainage
- be provided with weepholes or other suitable means of drainage.

6.10.16.2 Protection of steel at low level

The base rail of LSF should be kept a minimum of 150mm above the external ground level (or waterproofing layer of a flat roof, balcony or terrace) and cavity fill. In such cases, the LSF may be protected against corrosion in accordance with Clause 6.10.7.

Locally raised ground levels (up to the internal floor finish) to less than 15% of the external perimeter (of an individual building, eg row of terraced homes, apartment blocks and detached garages, measured on plan) to accommodate level thresholds can be accepted. The cavity should be kept clear and allow drainage. Wall insulation should overlap the base rail by a minimum of 150mm.

Figure 13: Ground level interface

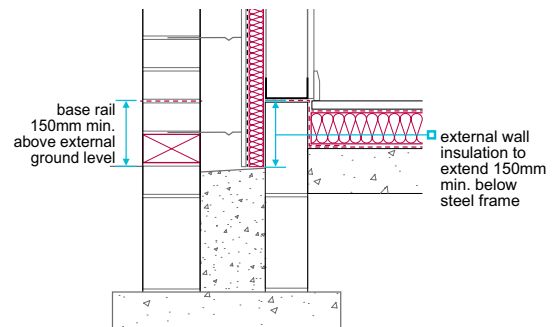

Alternatively, where the base rail or lowest steel is less than 150mm above ground level (or waterproofing layer of a flat roof, balcony or terrace), the design should consider the following:

- factory-applied protection to the steel frame to achieve a design life of 60 years. This may be LSF:
 - Galvanised to 600g/m², or
 - Galvanised to 275g/m² with the addition of two coats of heavy duty bituminous paint, 200µm total thickness
- sheathing, or backing boards to waterproofing, used below 150mm, should be service class 3 in accordance with BS EN 13986
- drainage of the cavity (ground conditions should be considered where the cavity discharges below ground level)
- insulation to limit thermal bridging and interstitial condensation. NHBC may ask for thermal modelling of the junction to demonstrate that these issues have been sufficiently limited.

Where levels are raised above the base rail or lowest steel:

- local areas of LSF walls (less than 15% of the external perimeter) retaining up to a maximum of 600mm of ground can be acceptable, subject to appropriate waterproofing design
- in addition, where more than 15% of the external perimeter has ground levels above the internal floor finish (up to a maximum of 600mm), the structure should be designed by an engineer in accordance with Technical Requirement R5.

Waterproofing should be designed by a waterproofing design specialist and be in accordance with Chapter 5.4 Waterproofing of basements and other below ground structures.

The manufacturer of the waterproofing system should confirm compatibility between the waterproofing and sheathing board, which should be supported by test evidence.

6.10.16.3 DPCs, DPMs and cavity trays

DPCs, DPMs and cavity trays should:

- be provided at openings to prevent rain penetration
- be installed underneath the full width of the base rail and lap with the DPM where present.
- materials assessed in accordance with Technical Requirement R3.

Materials acceptable for use as DPCs include:

- BS 6515 polyethylene
- BS 6398 bitumen

6.10.17 Insulation

Insulation shall be correctly installed, be of a suitable material and thickness to comply with Building Regulations and reduce the risk of interstitial condensation.

Insulation should:

- be inert, durable, rot and vermin proof, and should not be adversely affected by moisture or vapour
- cover the whole external face of the wall and be complete within the frame
- extend 150mm below the base rail to minimise thermal bridging and maintain a warm frame
- be tightly butted with joints of rigid board insulation taped, where required by the design.

Foil-faced insulation boards with an integral facing on one side only should be fixed with the foil face on the cavity side.

Table 9: Acceptable insulation materials

Material	Relevant standard
Mineral wool	BS EN 13162
Flame retardant (FR) grade expanded polystyrene	BS EN 13163
FR grade extruded polystyrene	BS EN 13164
Rigid polyurethane foam and polyisocyanurate	BS EN 13165
Phenolic foam	BS EN 13166
Cellular glass	BS EN 13167
Other insulation materials	Technical Requirement R3

Account should be taken of Accredited Construction Details where applicable.

Reference should be made to BRE document BR 135 Fire performance of external thermal insulation for walls of multi-storey buildings when specifying the type of insulation system to be installed.

6.10.18 Air and vapour control layers

Air and vapour control layers (AVCLs) shall restrict the passage of vapour from within the home to the steel frame and be correctly installed.

An AVCL should be provided, unless a condensation risk analysis shows it is not necessary. An analysis in accordance with BS EN ISO 13788 (Glaser method), using the following boundary conditions, will generally be acceptable:

- >60% internal RH
- at 21°C internally
- at -2°C externally.

Split layers of AVCL-type material should be avoided, except where condensation risk analysis shows it to be acceptable.

Where they are provided, AVCLs should be:

- 500g polyethylene sheet, vapour control plasterboard, or material assessed in accordance with Technical Requirement R3
- fixed on the warm side of the wall insulation and frame
- in accordance with the design
- placed to cover the external wall, including base rails, head rails, studs, lintels and window reveals
- overlapping the base rail
- fully sealed and punctures made good.

Where polyethylene sheet is used:

- each joint in the AVCL should be located on studs or noggings and lapped by a minimum of 100mm
- double-sided tape or adhesive should be used as a temporary fixing before the wall board is fixed.

Where vapour control plasterboard is used:

- joints between sheets should be positioned on studs or noggings
- care should be taken not to displace the vapour control material when cutting vapour control plasterboard.

6.10.19 Breather membranes

Breather membranes shall be capable of allowing vapour to pass into the cavity, and provided to protect the sheathing and frame from external moisture.

Breather membranes should be:

- vapour resistant to less than 0.6MNs/g (0.12 Sd) when tested in accordance with BS EN ISO 12572 using the set of conditions C and using five test specimens
- capable of resisting water penetration
- self-extinguishing
- durable
- installed so that each joint is protected and moisture drains outwards
- lapped to a minimum of 100mm at horizontal joints and a minimum of 150mm at vertical joints
- at least Class W2 to BS EN 13859-2 with no water leakage during testing. In areas of very severe exposure (see Clause 6.1.6 for classification of exposure zones) or where liquid water penetration of the cladding is anticipated, for example open-jointed cladding, Class W1 should be used. When open-jointed claddings are used or the membrane is likely to be left exposed during construction for a duration longer than normally to be expected (also see the membrane manufacturers' recommendations on exposure times), performance should be based on artificial aged behaviour in accordance with BS EN 13859-2. Where a vented and ventilated cavity with full rainscreen and no gaps, for example masonry or rendered board claddings, are used, performance should be based on artificial aged behaviour in accordance with BS EN 13111.

Breathable membranes should be used to protect sheathing board and insulation. Breather membranes may be omitted where water-resistant insulation boards with taped joints are used. Tape should be of a type recommended by the insulation manufacturer, breathable to allow water vapour to move freely and resist water penetration. Suitable taping should be applied at the lintel interfaces and other penetrations to direct water outside.

6.10.20 Cladding, lining and sheathing boards

Cladding panels, lining and sheathing boards shall be suitable for their intended purpose. Issues to be taken into account include:

- | | |
|--|--|
| <ul style="list-style-type: none"> 1) external cladding 2) sheathing | <ul style="list-style-type: none"> 3) internal lining boards. |
|--|--|

6.10.20.1 External cladding

The design and construction of the external walls should fully consider:

- cavity drainage
- differential movement
- restraint
- fire resistance.

In external walls, a clear cavity should be provided between the external insulation and the cladding. The cavity should:

- be drained
- have cavity trays and weepholes installed where the cavity is not fully maintained, eg at cavity barriers
- be kept clean, free of obstructions and capable of draining freely
- have drainage at its base, equivalent to 500mm²/m run, eg for masonry, one open perpend every 1.5m
- have drainage openings placed to prevent the ingress of rain.

Masonry cladding should:

- be constructed in accordance with Chapter 6.1 External masonry walls
- not be supported by the LSF walls unless designed in accordance with Technical Requirement R5
- be tied to the LSF walls with flexible wall ties fixed through to the studs
- include movement joints as appropriate (eg a 1mm gap per continuous metre of vertical clay masonry should be provided at openings and soffits) to allow for differential movement due to thermal expansion, shrinkage (in concrete masonry) and moisture expansion (in clay) in accordance with PD 6697. The brick/block manufacturer's advice should be sought on the level of movement to be expected.

Figure 14: Allowing for differential movement

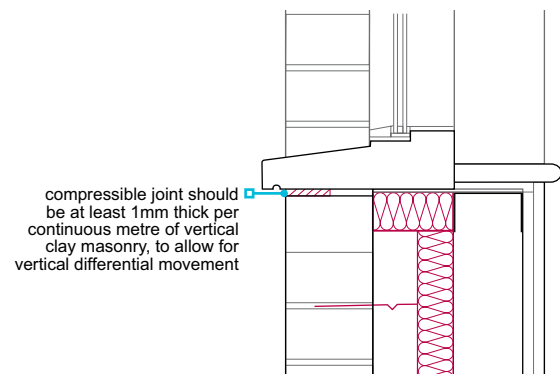

Lightweight cladding should be:

- in accordance with Chapter 6.9 Curtain walling and cladding
- compatible with the LSF system construction
- supported by systems assessed in accordance with Technical Requirement R3 which ensure that cladding design loads are effectively transferred to the building structure.

6.10.20.2 Sheathing

Sheathing boards should be:

- of a suitable strength and quality
- compatible with the steel frame
- attached using suitable quality fixings.

Sheathing boards contribute to meeting many of the critical performance issues described in Table 7 and cannot be easily replaced, so they should be specified in accordance with the design life of the building.

Sheathing boards should be appropriate for the exposure of the building and suitable for use in humid conditions.

Table 10: Requirements for sheathing board materials

Material	Relevant standards	Minimum thickness (mm)
Cement bonded particle board	BS EN 13986 BS EN 634 BS EN 12467	By design
Oriented strand board (OSB3 required)	BS EN 300	8.0
Plywood	BS EN 13986 BS EN 636	5.5
Proprietary materials	Technical Requirement R3	Technical Requirement R3

Fixings used to apply sheathing boards should be selected in accordance with the board manufacturer's instructions and be suitably specified for strength and long-term durability in the anticipated exposure condition.

Sheathing boards should be adequately protected from weather during construction. This can be done through a combination of:

- the use of water-resistant boards with accredited proof of performance in accordance with Technical Requirement R3
- the use of sealed jointed water-resistant insulation to reduce water penetration
- the application of a breathable membrane to the sheathing board
- sequencing construction to minimise daily exposure with fully waterproof temporary coverings overnight and during inclement weather.

For all sheathing board types, junctions between adjacent boards, and at interfaces with other building elements, should be sealed and/or taped in accordance with the manufacturer's recommendations.

A breather membrane should be used to provide protection to the building during and after construction in areas of very severe exposure to wind-driven rain.

6.10.20.3 Internal lining boards

Internal lining boards should be:

- fixed in accordance with the design and the manufacturer's recommendations
- attached to light steel studs using self-drilling, self-tapping screws at a maximum of 300mm centres.

In addition to the general guidance for internal lining boards, plasterboard should:

- be shown to provide adequate fire resistance where required
- comply with BS EN 520 and be in accordance with Chapter 9.2 Wall and ceiling finishes
- be a minimum of 9.5mm for stud spacing up to 450mm
- be a minimum of 12.5mm for stud spacing up to 600mm.

6.10.21 Wall ties

Wall ties shall be suitable to connect the steel frame to the cladding.

Generally, wall ties should be:

- in accordance with BS 845-1
- fixed to the studs and not the sheathing
- inclined away from the LSF
- austenitic stainless steel and of a type which accommodates the differential movement between the LSF and the cladding, or assessed in accordance with Technical Requirement R3.

Figure 15: Providing wall ties

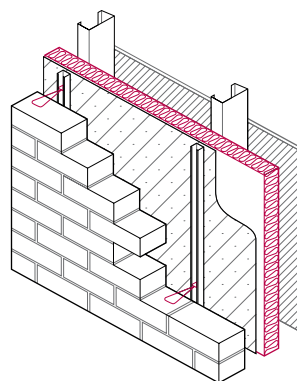

Wall ties for masonry cladding should be according to the design and:

- installed at a minimum density of 3.7 ties/m², eg spaced at a maximum of 600mm horizontally and 450mm vertically (except where alternative densities have been demonstrated by building specific calculation and accepted under the Stage 2 certificate)
- spaced at jambs of openings, a maximum of 300mm vertically within 225mm of the masonry reveal (additional studs may be needed to achieve this)
- kept clean and free from mortar droppings.

6.10.22 Services

Services shall be adequately protected from damage.

Service mains and service outlets should be:

- designed to ensure the fire resistance of walls and floors is not impaired
- designed to ensure that the required sound insulation of walls and floors is maintained
- installed in accordance with the design
- on the warm side of the insulation.

Light steel joists or studs should not be notched to accommodate services. Holing of structural light steel members should be carried out in accordance with this chapter and the manufacturer's recommendations. On-site hole cutting should be avoided, as badly cut edges can have an adverse effect on the durability of the frame and may cause damage to pipes and cables.

Where on-site adaptation of the frame is unavoidable, it should be undertaken by the manufacturer, with prior notification to NHBC, and completed in line with the steel frame designer's remedial details with all cut edges treated and badly cut edges avoided. Significant adaptations should be overseen by the design engineer.

Grommets should be used around the edge of service holes to protect electrical cables and reduce the risk of bimetallic corrosion between the LSF and copper pipes. Swaged holes for electric cables and plastic piping do not require grommets.

In Scotland, services are not permitted within:

- framed separating walls
- separating wall cavities.

6.10.23 Further information

- *The Steel Construction Institute (SCI) publications, Silwood Park, Ascot, Berkshire, SL5 7QN*
SCI publications:
 - *Building design using cold formed steel sections: construction detailing and practice (P165)*
 - *Modular construction using light steel framing: design of residential buildings (P302)*
 - *Light steel framing in residential construction (P402)*
 - *Design and installation of light steel external wall systems (ED017)*
 - *Design of stability systems for light steel framing (P437)*



Chapter 6.11



Render

This chapter gives guidance on meeting the Technical Requirements for factory-made and traditional render applied to external walls and render onto board backgrounds.

Render intended for below ground waterproofing is outside the scope of this chapter (see Chapter 5.4 Waterproofing of basements and other below ground structures). Chapter 6.9 Curtain walling and cladding contains guidance for insulated render systems.

6.11.1	Compliance	02
6.11.2	Provision of information	02
6.11.3	Weather conditions	03
6.11.4	Backgrounds	04
6.11.5	Accommodation of movement	05
6.11.6	Mixes	06
6.11.7	Detailing	09
6.11.8	Render onto board backgrounds	11
6.11.9	Finishes	13
6.11.10	Further information	13



Figure reference table

Fig No	Title/Description	Clause	Page
Figure 1	Typical movement joint	6.11.5.1	5
Figure 2	Metal lath reinforcement and separation strip (min. 300mm)	6.11.5.2	6
Figure 3	Detailing of copings to protect render	6.11.7.1	9
Figure 4	Coping detail to protect render	6.11.7.1	9
Figure 5	Provision of weepholes to window head	6.11.7.3	10
Figure 6	Checked rebate	6.11.7.4	10

Introduction

This chapter is arranged in sections covering:

- site- and factory-made render
- render onto board backgrounds
- detailing.

Definitions for this chapter

Background	The surface to which the render is applied.
Base coat	The first render coat.
Cured	The finished render state when all chemical reactions have taken place.
Decorative finishes	An aesthetic finish not generally contributing to weathertightness.
Dry dash	Aggregate applied to finish the render.
Factory-made	Render mortar arriving on site premixed, generally including admixtures and colouring, and either ready to use or requiring only the addition of water.
Final coat	The last render coat.
Movement joint	A joint designed to accommodate predicted movement in the background or render.
Preparation coat	An application to provide an appropriate key or bond, including a spatterdash or stipple coat.
Proprietary render systems	Renders and their specified backgrounds with proven compatibility, which fall outside the guidance given for site- and factory-made renders.
Ribbed metal lathing	Metal lathing that can be used as a carrier for render.
Site-made	Renders made on site to recognised designated or prescribed mix proportions.
Structure	Structural elements of the building providing support to the render or proprietary render system.
Substrate	The wall composition which offers support to the background intended to be rendered (the substrate and background may sometimes be the same).
Undercoat	The coats preceding the final coat.
Wet dash	A traditional render consisting of aggregate bound in slurry applied to the undercoat prior to setting.

6.11.1 Compliance

Also see: BS EN 13914-1 and BS 8000-0

Render, including site-made, factory-made and render onto board backgrounds, shall comply with the Technical Requirements.

Render that complies with the guidance in this chapter will generally be acceptable.

6.11.2 Provision of information

Designs and specifications shall be produced in a clearly understandable format, include all relevant information and be distributed to all appropriate personnel.

Design and specification information should be issued to site supervisors, relevant specialist subcontractors and/or suppliers and, where relevant, include the following information:

- a full set of drawings indicating areas to be rendered, and construction details, eg the position of movement joints and how interfaces are formed
- the render manufacturer's technical information, including parts of the system design manual or installation guidance relevant to the specific site and construction type
- mix proportions for site-made render
- details of the substrate and background
- details of any technical assessments (ie, third-party certifications)
- details of interfaces and abutments, such as joints, junctions and service penetrations
- ancillaries that form part of a rendering system.

Table 1: Process chart for the application of site- and factory-made render to masonry backgrounds

Process	Steps	See Clause
Structure design	Identify a suitable background material compatible with the intended render finish and consider any preparation requirements	6.11.4
	↓	
	Consider how movement will be controlled ie, are movement joints or bed joint reinforcement needed?	6.11.5
Render design	↓	
	Select an appropriate render strength that is compatible with the background	6.11.6
	↓	
	Determine the exposure zone which will influence the render's thickness	6.11.6
Construction	↓	
	Protect the background from adverse weather conditions at the earliest opportunity during and following construction	6.11.3
	↓	
	Assess the likely weather conditions prior to and after rendering	6.11.3
	↓	
	Assess the background, eg suction and surface preparation, and apply a preparation coat where necessary	6.11.4
	↓	
	Protect the completed render as it cures	6.11.3

6.11.3 Weather conditions

Rendering shall only be carried out in suitable weather conditions unless appropriate precautions are taken.

Consideration should be given to likely weather conditions and, where required, measures taken to allow render to cure satisfactorily.

When applying render in wet conditions:

- the background should not be saturated
- downpipes or temporary downpipes should be used to prevent the background or completed render from becoming saturated
- curing render should be protected from heavy rainfall
- specialist preparation coats should be used in accordance with the manufacturer's recommendations.

When applying render in hot conditions, the following precautions should be considered:

- avoid curing render from being directly exposed to strong sunlight
- lightly spray the render with clean water to prevent rapid drying.

When applying render in cold conditions:

- the air temperature should be at least 2°C and rising
- the background should be free from visual signs of frost
- the background should not be saturated.

Where the air temperature is at, below or likely to fall below 5°C, appropriate precautions such as covering with a hessian sheet should be used to protect curing render.

Factory-made render should be installed in accordance with the manufacturer's recommendations for weather conditions.

Acrylic renders have different curing requirements which should be considered.

6.11.4 Backgrounds

Backgrounds shall be appropriate for their intended purpose and suitably prepared to receive render. Issues to be taken into account include:

- 1) preparation of masonry backgrounds
- 2) preparation of clay brick backgrounds
- 3) ribbed metal lath.

6.11.4.1 Preparation of masonry backgrounds

Masonry backgrounds should be constructed in accordance with Chapter 6.1 External masonry walls and include DPCs and cavity trays. The thickness of single-leaf masonry walls should be in accordance with PD 6697.

The surface to be rendered should be free from dust, loose particles, efflorescence and organic growth, and, where applicable, be prepared in accordance with the render manufacturer's recommendations.

Masonry backgrounds with a smooth surface or close texture should be treated to provide an adequate key by either applying:

- lath, or
- a spatterdash or stipple coat.

The suction of the block should be appropriate for rendering. High or low suction will generally require a preparatory coat. The likely suction of the block can be gauged by applying a small quantity of water to the surface and observing the effects:

- water being absorbed instantly is an indication of high suction
- water running from the surface with little absorption suggests the background has low suction.

A spatterdash coat typically comprises cement and sand at a ratio of 1:3 mixed with water and often a bonding agent, such as styrene-butadiene rubber (SBR) or ethylene vinyl acetate (EVA). The mix should be applied by dashing onto the background to give a rough texture approximately 3-7mm thick.

Generally, raking out mortar joints to blockwork will not sufficiently improve the key, and may extend the curing time of the base coat.

6.11.4.2 Preparation of clay brick backgrounds

The brick manufacturer's recommendations for rendering should be followed.

Where S1 bricks are used, the render mix should resist sulfate.

To provide an appropriate bond, clay brick backgrounds with a water absorption rate of between 9% and 15% should generally have sufficient suction to provide a mechanical key. Alternatively, when rendering onto bricks, one or more of the following methods of improving the key can be adopted:

- keyed bricks used
- mortar joints raked out to a depth of 10-12mm (although this may increase curing time).
- a spatterdash coat applied

Render on an external leaf of clay bricks (F2,S1 or F1,S1 designation bricks to BS EN 771) in severe or very severe exposures is not permitted where the cavity is to be fully filled with insulation.

6.11.4.3 Ribbed metal lath

Ribbed metal lath should be:

- fixed in accordance with the manufacturer's recommendations
- supported at 350mm and up to 600mm centres for stiffer metal profiles
- fixed with the correct side to be rendered facing out
- fixed with a 25mm drained and vented cavity when applied to framed structures
- austenitic stainless steel to BS EN 10088-1.

Render onto ribbed metal lath can be vulnerable to damage where impact is likely to occur, such as beside communal paths. Appropriate reinforcement may be used to help improve the render's impact resistance.

6.11.5 Accommodation of movement

Also see: PD 6697

Rendered walls shall be detailed to reduce the risk of damage due to movement in the background. Issues to be considered include:

- 1) movement in masonry background
- 2) dissimilar materials
- 3) movement in ribbed metal lath render.

The construction should include appropriate measures to reduce the risk of damage to the render caused by movement in the background, such as shrinkage, thermal or differential movement. The designer should follow the guidance in this chapter, together with the render/background manufacturer's recommendations. Alternatively, provision for movement should be designed by an engineer in accordance with Technical Requirement R5.

Areas of the building to be rendered should be identified prior to construction, and movement control considered as part of the design.

6.11.5.1 Movement in masonry background

Render and masonry backgrounds should be detailed to reduce the likelihood of cracking and crazing in the render. Issues to be considered include:

- the potential for movement in the background and render
- size, quantity and positioning of openings
- compatibility with the background
- density of the masonry
- the size and geometry of rendered panels
- the orientation of the building
- thermal shock
- moisture content of the materials
- exposure conditions.

Where length/height ratios are greater than 3:1, consideration should be given to providing suitably designed:

- movement joints, or
- bed joint reinforcement.

Where movement joints are provided, they should:

- be continued through the background and render (including any horizontal beads)
- be made weathertight with an appropriate sealant
- not align with openings such as windows, doors or meter boxes.

Austenitic stainless steel bed joint reinforcement conforming to BS EN 845-3 should be provided in the first two courses of the external masonry leaf above and below any opening to help distribute tensile stress and avoid localised cracking. Where possible, the reinforcement should project 600mm beyond the opening.

Figure 1: Typical movement joint

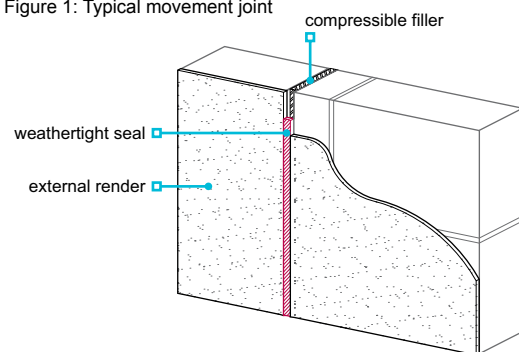

Table 2: Concrete block categorisation

Category	Compressive strength of the blockwork	Dry density
Low density aircrete	2.9-3.6N/mm ²	<500kg/m ³
Normal density aircrete	3.6-9.0N/mm ²	500kg/m ³ +
Ultra lightweight aggregate	3.6-7.3N/mm ²	<950kg/m ³
Lightweight aggregate	3.6-7.3N/mm ²	950-1,500kg/m ³
Dense aggregate	7.3N/mm ² +	1,500kg/m ³ +

Table 3: Preparation of blockwork backgrounds⁽¹⁾

Category	Normal movement joint spacing	Maximum distance of joint from restrained end ie, corners	Suction control
Low density aircrete	Specialist advice required ⁽²⁾		
Normal density aircrete	6m	3m (half normal spacing)	Yes
Ultra lightweight aggregate	6m	3m (half normal spacing)	Not generally required
Lightweight aggregate	6m	Half normal spacing	Not generally required
Dense aggregate	7.5—9m ⁽³⁾	Half normal spacing	Not generally required

Notes

1. The guidance in this table is generally acceptable for render coats in accordance with Table 5 and factory-made one-coat render based on 1:1:6 mix = 3.5N/mm².
2. Specialist advice from the block and render manufacturer should be sought.
3. Specialist advice should be sought where clay brick backgrounds are used.

6.11.5.2 Dissimilar materials

Backgrounds should not be constructed from materials of different densities. Where possible, render should not be continuous across dissimilar materials. Where this cannot be avoided, the render should:

- be stopped at appropriately formed movement joints, or
- have austenitic stainless steel lath reinforcement carried across the joint with a separation strip, such as building paper, behind.

Where significant differential movement is likely to occur, such as the junction between masonry and board backgrounds, render should be stopped either side of an appropriately formed joint.

6.11.5.3 Movement in ribbed metal lath render

To avoid cracking, ribbed metal lath backgrounds should be divided with movement joints into bays no more than 5m wide and:

- site-made render should be applied in three coats
- factory-made render should be applied in accordance with the manufacturer's recommendations.

Figure 2: Metal lath reinforcement and separation strip (min. 300mm)

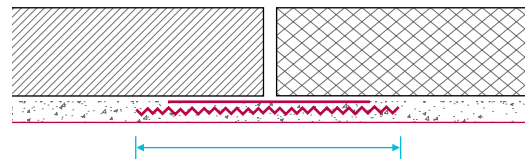

6.11.6 Mixes

Also see: Chapter 6.1

The render mix shall be appropriate for the intended purpose, be compatible with the background and be designed to minimise the risk of de-bonding, cracking and crazing. Issues to be considered include:

- | | |
|---------------------------------------|------------------------------------|
| 1) sand | 5) application of site-made render |
| 2) mix design | 6) factory-made renders |
| 3) admixtures and bonding agents | 7) lime. |
| 4) coat thickness of site-made render | |

Render coats should not be stronger than the background or any previous coat to which they are applied. Weaker coats can be achieved by reducing the cement content of each coat or by using the same mix but decreasing the coat thickness.

Potable water should be used for mixing render.

6.11.6.1 Sand

Sand for render should be well-graded category 2, in accordance with BS EN 13139. Sand with excessive fine material, clay or silt can shrink and crack so should be avoided.

A sharp gritty or coarse sand is required for strength in the backing coats, but finer sand should be used for the finishing coat.

Typical sand grades should be:

- 5mm down to 0.075mm — undercoat(s)
- 1.18mm down to 0.075mm — final coat.

6.11.6.2 Mix design

Designation ii, iii and iv (strength class M6, M4 and M2) mixes are generally used for rendering.

Stronger mixes are generally more moisture resistant; however, they are also more prone to shrinkage, which increases the likelihood of the render cracking. Weaker mixes may be appropriate for weaker backgrounds in less exposed zones.

For exposure zone classification, see Clause 6.1.6.

Table 4: Designation mix proportions for cement-based mixes

	Mix designation	Mortar compressive strength class equivalent	Mix proportions by volume based on damp sand				
			Cement:lime:sand	Cement:ready-mixed lime/sand ⁽¹⁾	Cement:sand ⁽¹⁾ (using plasticiser)	Masonry cement:sand ⁽¹⁾	
			Ready-mixed lime:sand	Cement: ready-mixed material			
Weaker – stronger	i	M12	1:¼:3	1:12	1:3	-	-
	ii	M6	1:½:4 - 4½	1:9	1:4 - 4½	1:3 - 4	1:2½ - 3½
	iii	M4	1:1:5 - 6	1:6	1:5 - 6	1:5 - 6	1:4 - 5
	iv	M2	1:2:8 - 9	1:4½	1:8 - 9	1:7 - 8	1:5½ - 6½
	v	-	1:3:10 - 12	1:4	1:10 - 12	-	-

Notes

1. With fine or poorly graded sands, the lower volume of sand should be used.
2. Where soluble salts could be present in the background, mixes should have sulfate-resisting properties.
3. Where pigments are specified, batching should be undertaken with care to ensure colour consistency pigments to BS EN 12878 can be used but should not exceed 10% of the cement weight, or 3% where carbon black is used (white Portland cement may be used).

Render mixes should be:

- in accordance with BS EN 13914 Design, preparation and application of external rendering and internal plastering
- appropriate to the strength of the background
- checked against the specification
- of adequate strength and thickness to achieve durability.

Where enhanced water-resisting properties are required:

- Portland cement with a waterproofing agent already incorporated may be used in the undercoat, or
- a waterproofing agent should be added to the render mix in accordance with the manufacturer's recommendations.

Rendering mortar should not be left turning over in the mixer for longer than necessary.

6.11.6.3 Admixtures and bonding agents

Admixtures and bonding agents should:

- be assessed in accordance with Technical Requirement R3
- be used in accordance with the manufacturer's recommendations
- be compatible with the render
- not be used with factory-made renders without the prior approval of the render manufacturer.

The effect on the adhesion of subsequent render coats should be considered when water-repelling agents are used.

Plasticisers and air entrainers should comply with BS EN 934 and not be used in mortars containing masonry cement.

6.11.6.4 Coat thickness of site-made render

The number of coats should be designed to take account of the background and exposure conditions of the site.

The mix and its application should be suitable for the specific background. Items to consider include:

- the number and thickness of coats
- the strength of the coat (subsequent coats should be weaker than the background or the previous coat).

Render should have a nominal total finished thickness of not less than:

- 16mm for sheltered and moderate exposure zones, or
- 20mm for severe and very severe exposure zones.

Table 5: Site-made render designation and typical thickness

	Typical two-coat application
Normal density aircrete	
Undercoat	8-12mm designation iii (M4)
Final coat	6-8mm designation iv (M2) ⁽¹⁾
Ultra lightweight and lightweight aggregate blockwork	
Undercoat	8-12mm designation iii (M4)
Final coat	6-8mm designation iv (M2) ⁽¹⁾
Dense aggregate blockwork	
Undercoat	8-12mm designation ii (M6)
Final coat	6-8mm designation iii (M4)
Clay brick	
Undercoat	8-12mm designation ii (M6)
Final coat	6-8mm designation iii (M4)
Ribbed metal lath	
First coat	8-12mm designation i (M12)
Undercoat	10-12mm designation ii (M6)
Final coat	6-8mm designation ii (M4)

Notes

1. Designation iii (M4) should be used for the final coat in severe or very severe exposure zones.
2. For block classifications, see Table 2.
3. Specialist advice should be sought for low density aircrete backgrounds.

Where a three-coat render is used, this should include a second undercoat that is:

- the same thickness but a slightly weaker mix than the first undercoat, or
- a slightly thinner coat of the same strength mix.

6.11.6.5 Application of site-made render

When applying render, previous coats should be allowed to cure before applying the next coat (typically three to four days).

To avoid surface crazing:

- properly graded sand should be used with limits on fine sand proportions
- overworking (polishing) of the render should be avoided, as this causes laitance to be drawn to the surface.

Surfaces should be appropriately prepared to receive following coats. This can be achieved by either combing or scratching. The final coat should be applied to an undercoat that is suitably keyed.

The size of the background to be rendered should be assessed to determine if it can be rendered in the time available. This will help to establish the most suitable location for day joints.

The final coat should be of uniform thickness and not used to even out irregularities, which should be accommodated in previous coats.

6.11.6.6 Factory-made renders

Factory-made renders should be applied in accordance with the manufacturer’s recommendations, including those for ancillary components.

Factory-made renders with a declared mix in accordance with Table 4, applied to the thickness recommended in Table 6, and that otherwise comply with the recommendations for site-made renders, will generally be acceptable to NHBC.

Table 6: Minimum thickness of factory-made single-coat renders

Background	Sheltered and moderate exposure zone	Severe and very severe exposure zone
Single-leaf masonry wall	20mm	In accordance with the render manufacturer's recommendations
Masonry cavity wall partially filled	15mm	
Masonry cavity wall fully filled	20mm	
Lath ⁽¹⁾	15mm	

Notes

- Lath backgrounds generally require two coats.
- Alternative single-coat thicknesses may be acceptable when accompanied by appropriate third-party assessment in accordance with Technical Requirement R3.

6.11.6.7 Lime

Render mixes containing hydrated lime can improve the ability of the render to accommodate movement, improving resistance to cracking and crazing. The use of lime should be in accordance with BS EN 459.

Natural hydraulic lime (NHL) is used without cement, which can allow greater moisture vapour movement through the structure. Specialist advice may be required for the use of NHL render.

6.11.7 Detailing

Rendering shall be detailed to ensure appropriate weathertightness and durability. Issues to be considered include:

- 1) copings, cappings and sills
- 2) abutments and interfaces
- 3) weepholes
- 4) detailing at openings
- 5) exposed elements
- 6) ancillary items
- 7) render below the DPC
- 8) resistance to sulfate attack.

6.11.7.1 Copings, cappings and sills

Render should be protected from damage by copings, cappings or sills made of a material of low permeability or with suitably detailed DPCs. All copings, cappings and sills should have an efficient throat or drip on the underside which should be not less than 40mm away from the face of the rendered wall.

Extending sills or sub-sills beyond window reveals can help to disperse water and prevent staining.

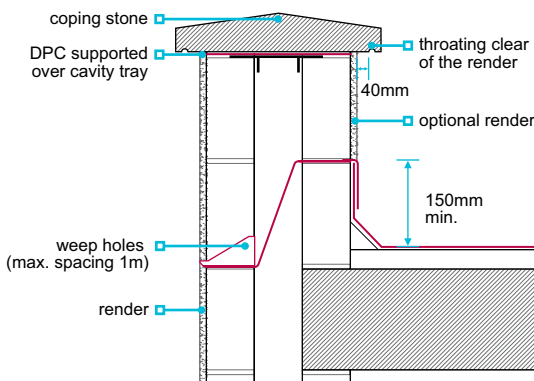
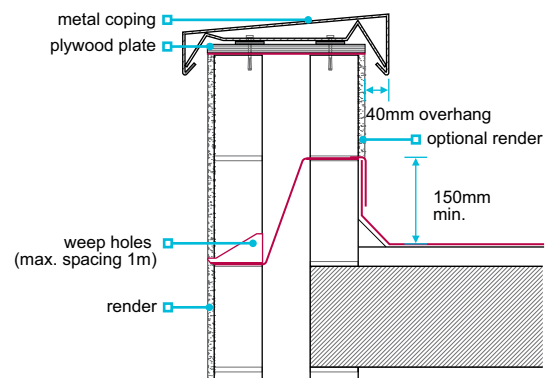
Figure 3: Detailing of copings to protect render

Figure 4: Coping detail to protect render

6.11.7.2 Abutments and interfaces

Where raked roof abutments occur against a rendered masonry wall, preformed cavity trays and appropriate flashings should be provided. Clauses 6.1.17 and 7.2.20 contain guidance for stepped cavity trays and flashings to masonry walls.

Cavity trays with stop ends are required above all openings. Where required, a minimum of two weepholes per opening should be provided.

A site-made or preformed cavity tray should be provided at horizontal abutments with weepholes at maximum 1m centres.

Render abutting exposed features, such as stone string courses or quoins, should be finished neatly without gaps.

Abutments between render and exposed masonry should be detailed to prevent moisture passing in behind the render or adversely affecting the building.

When rendering into window or door frames, the render should be stopped against a bead and sealed, or a bead of sealant applied between the frame and render.

6.11.7.3 Weepholes

Weepholes should be provided:

- where required for ventilation to timber frame construction
- to cavity trays in parapet walls and horizontal roof abutments at not more than 1m centres
- to the last tray at stepped abutments
- in severe or very severe exposure zones where rendering is returned into the window or door head (weepholes are not required where the render is not returned).

To prevent staining, weepholes should be of a type which restricts the entry of wind-driven rain.

Figure 5: Provision of weepholes to window head

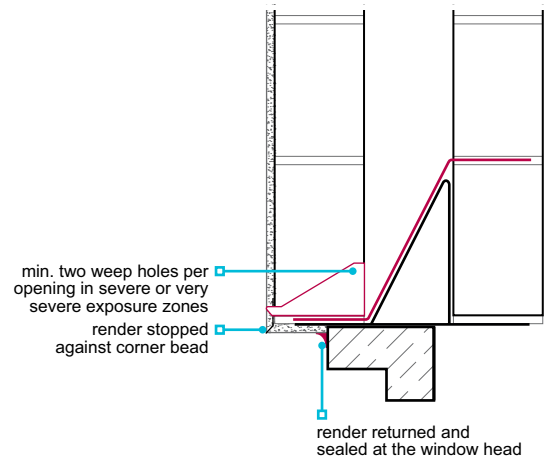

6.11.7.4 Detailing at openings

Design features around openings and at the head of the rendering should provide shelter and help shed water away from the surface below.

Checked rebates should be used in:

- Scotland
- Northern Ireland
- Isle of Man
- areas where the exposure to driving rain is very severe (severe/very severe exposure when building using timber frame).

Alternatively proprietary cavity closers which hold a satisfactory assessment by an appropriate independent technical approvals authority, accepted by NHBC, for the exposure zone may be acceptable.

Proprietary render systems should be detailed at abutments in accordance with the manufacturer's recommendations.

Figure 6: Checked rebate

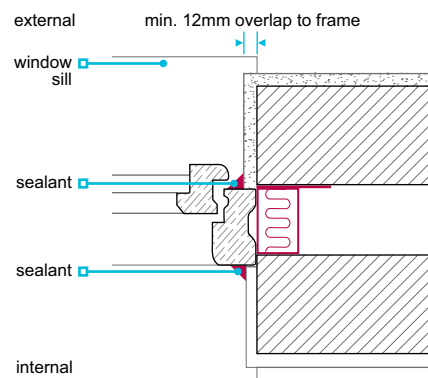

6.11.7.5 Exposed elements

Render to exposed masonry elements, such as parapets, freestanding walls, pillars, retaining walls or chimneys, should be of a type appropriate for severe exposure conditions.

When rendering both sides of freestanding or parapet walls of single leaf construction, care should be taken to prevent damage caused by moisture becoming trapped. For example:

- the detailing should prevent the masonry from becoming saturated
- the wall should be protected from rain during construction
- rendering both sides of single leaf walls in areas of very severe exposure to frost attack should be avoided (see Clause 6.1.6c).

Bricks with S1 or S0 designation are not recommended for exposed elements that are to be rendered.

6.11.7.6 Ancillary items

Stop beads and render stops should be austenitic stainless steel or PVC. Long runs of steel beads and stops should be avoided due to their expansion potential.

Corner beads should have an appropriate projection to prevent thin tapering of the render which reduces its overall thickness.

Beads should be:

- adhesive-fixed using a material appropriate for external use and in accordance with the manufacturer's recommendations, or
- mechanically fixed using suitably durable fixings.

6.11.7.7 Render below the DPC

To prevent damage caused by prolonged periods of wetting, it is preferable to stop the render at DPC level. Where rendering is continued below the DPC, the following precautions should be taken:

- for site-made render, use a stronger mix (M4) that is sulfate resisting, or
- use factory-made render in accordance with the manufacturer's recommendations.

Consideration should be given to providing:

- appropriate drainage installed along the perimeter or ground falling away from the building
- adjacent surface finishes which do not promote splashing.

Admixtures may be required to enhance performance.

6.11.7.8 Resistance to sulfate attack

To prevent sulfate attack, the wall construction should restrict moisture from entering the background and having a detrimental effect on the performance of the render.

When detailing between the render and exposed brickwork, it is advisable to use appropriate materials resistant to, or without sources of, sulfate.

6.11.8 Render onto board backgrounds

Render onto board backgrounds shall be suitable for the intended use and detailed to provide satisfactory performance. Issues to be considered include:

- 1) provision of a system manual
- 2) compatibility between the render and background
- 3) fixing back to the structure
- 4) weather resistance
- 5) movement joints
- 6) board backgrounds.

6.11.8.1 Provision of a system manual

Where render is applied to a board background, the render manufacturer should clearly define the system in a manual, including:

- materials and components
- common details
- design guidance
- installation guidance.

The system should be used in full accordance with the manufacturer's guidance and third-party certification.

6.11.8.2 Compatibility between the render and background

The background should be appropriate for its intended use. Issues to be considered include:

- compatibility between the board and render
- durability classification of the board and its suitability for use in exterior conditions, including resistance to weather prior to the render being applied.

Render onto board backgrounds should:

- not be applied where the surface has contamination, dust or loose particles
- consider the effects of solar radiation (colour, orientation and shading)
- be mixed to ensure colour consistency where coloured pigments are specified
- be specified and used with the appropriate ancillary items, such as trims to form corners and returns.

Boards should not be left exposed prior to rendering for longer than is necessary.

6.11.8.3 Fixing back to the structure

Board backgrounds should be fixed back to the structure in accordance with the manufacturer's recommendations and third-party certification.

The fixing design should consider:

- negative (suction) and positive (pressure) wind loads
- pull-out strength
- pull-through resistance
- anticipated movement
- self-weight.

A suitably qualified and experienced chartered engineer should check that an adequate number of fixings are used to attach the system.

Fixing battens and rails should be installed vertically and not block drainage paths. Timber battens should be suitably treated.

To reduce the risk of damage from impact, especially at low level, where people have access around balconies and where cradle systems, etc can meet the façade, appropriate precautions such as closer supports should be considered.

Cavity barriers should be appropriately detailed to ensure satisfactory performance and:

- be provided in accordance with Building Regulations
- not block ventilation or drainage paths
- account for movement in the frame
- be used in accordance with the manufacturer's recommendations.

6.11.8.4 Weather resistance

Timber and steel framed backing walls should be protected with breather membranes and have a minimum 25mm cavity.

Cavities to timber framed walls should be drained and vented, and cavities to steel framed walls should be drained.

6.11.8.5 Movement joints

Movement joints should be provided to accommodate movement in timber frame structures. Where board backgrounds are used, movement joints should be:

- formed in accordance with the system manufacturer's recommendations
- continued through the background board
- positioned to accommodate calculated deflection or movement
- provided at floor zones.

6.11.8.6 Board backgrounds

Board backgrounds to be rendered should be external grade and recommended for use in the render manufacturer's system manual and third-party certification.

Boards should be set out in accordance with the system manufacturer's recommendations, taking account of possible compression, deflection and alignment of joints in relation to openings in the external wall, such as windows and doors.

The render should have alkali-resistant mesh embedded into the base coat across the whole surface.

Edges of boards should be suitably treated to provide protection from weather during construction and to maintain durability after the render is completed.

6.11.9 Finishes

Finishes shall be to a satisfactory standard. Issues to be considered include:

- 1) decorative finishes
- 2) appearance.

6.11.9.1 Decorative finishes

The choice of decorative finish should take account of:

- the exposure zone
- background movement potential.

Scraped or textured finishes can reduce the risk of crazing and can break up the drainage path of rainwater as it runs down the face of the wall.

Wet dash and dry dash finishes should have an aggregate size generally between 6mm and 14mm. Dry dash should be applied to the final coat before it has fully cured.

6.11.9.2 Appearance

Render on external walls should be reasonably consistent in texture, finish, colour and line. Clause 9.1.2.2 provides further guidance on tolerances to render finishes.

Consideration should be given to detailing that will avoid obvious staining (eg the positioning of discharge pipes).

Completed render should be protected from damage that could be caused by construction activities.

Render may not be resistant to staining and may require periodic maintenance such as cleaning.

6.11.10 Further information

- *BS EN 13914-1 Design, preparation and application of external rendering and internal plastering — External rendering*
- *BS 8000-0 Workmanship on construction sites — Introduction and general principles*
- *PD 6697 Recommendations for the design of masonry structures to BS EN 1996-1-1 and BS EN 1996-2*



NHBC

Part 7

Roofs



Flat roofs, terraces and balconies

This chapter gives guidance on meeting the Technical Requirements for flat roofs, terraces and balconies.

7.1.1	Compliance	06
7.1.2	Provision of information	07
7.1.3	Flat roof, terrace and balcony general design	07
7.1.4	Drainage	09
7.1.5	Flat roof, terrace and balcony structural design	11
7.1.6	Timber structure and deck	12
7.1.7	Concrete decks	15
7.1.8	Profiled self-supporting metal roof decks	16
7.1.9	Profiled self-supporting metal roofing	17
7.1.10	Thermal insulation and vapour control	19
7.1.11	Waterproofing layer and surface treatments	22
7.1.12	Green and biodiverse roofs – including roof gardens	27
7.1.13	Blue roofs	28
7.1.14	Raised and buried podiums	29
7.1.15	Detailing of flat roofs	30
7.1.16	Accessible thresholds and upstands	33
7.1.17	Metal balcony decking systems	35
7.1.18	Parapets and guarding to terraces and balconies	35
7.1.19	Further information	38



Figure reference table

Figure Reference Table 7.1			
Fig No	Title/Description	Clause	Page
Figure 1	Individual reinforced concrete (RC) elements	7.1.3	7
Figure 2	Warm roof	7.1.3	7
Figure 3	Cold roof	7.1.3	7
Figure 4	Inverted warm roof	7.1.3	7
Figure 5	Uninsulated Roof Deck Construction	7.1.3	7
Figure 6	Roof toppings	7.1.3	8
Figure 7	Paving	7.1.3	8
Figure 8	Uninsulated decks	7.1.3	8
Figure 9	Warm roof construction	7.1.3	8
Figure 10	Inverted warm roof construction	7.1.3	8
Figure 11	Cold roof construction	7.1.3	9
Figure 12	Blue Roof make-up	7.1.3	9
Figure 13	Firrings used to form deck fall gradient	7.1.4.2	10
Figure 14	Joist hanger	7.1.6.2	13
Figure 15	Joist strap	7.1.6.2	13
Figure 16	Softwood tongued and grooved boarding	7.1.6.3	14
Figure 17	Profiled metal deck features	7.1.8.3	17
Figure 18	Warm roof construction — with metal deck	7.1.8.3	17
Figure 19	Inverted warm roof construction	7.1.8.3	17
Figure 20	Twin skin build-up	7.1.9	18
Figure 21	Standing seam roof (secret fixings)	7.1.9	18
Figure 22	Example of edge seal with composite roof panels	7.1.9	19
Figure 23	Composite insulated timber deck	7.1.10.2	20
Figure 24	Ventilated cold roof design	7.1.11.2	25
Figure 25	Ventilated warm roof design	7.1.11.2	25
Figure 26	Intensive Green Roof on warm roof deck	7.1.12	27
Figure 27	Extensive Green Roof on warm roof deck	7.1.12	27
Figure 28	Intensive Green Roof on inverted warm roof deck	7.1.12	27
Figure 29	Extensive Green Roof on inverted warm roof deck	7.1.12	27
Figure 30	Raised podium	7.1.14	29
Figure 31	Buried podium	7.1.14	29
Figure 32	Upstands	7.1.15	30
Figure 33	Skirting to rooflights or ventilator kerb	7.1.15	30
Figure 34	Twin-kerb expansion joint	7.1.15	30
Figure 35	Mansard edge	7.1.15	31
Figure 36	Pitched roof abutment	7.1.15	31
Figure 37	Independent skirting detail	7.1.15	31
Figure 38	Verge detail	7.1.15	31
Figure 39	Welded drip to external gutter	7.1.15	31
Figure 40	Pipe passing through roof	7.1.15	31
Figure 41	Upstand to ventilator or rooflight kerb	7.1.15	32
Figure 42	Rainwater outlet	7.1.15	32
Figure 43	Inverted warm roof drainage outlet	7.1.15	32
Figure 44	Uninsulated balcony deck	7.1.16	33
Figure 45	Insulated terrace deck	7.1.16	34
Figure 46	Accessible threshold	7.1.16	34
Figure 47	Parapet wall waterproofing details at roof upstand and head coping	7.1.18.3	36

Figure 48	Parapet detail with waterproofing taken over top of wall and finished with edge trim	7.1.18.4	36
Figure 49	Pitch pocket sealing detail around post fixed to deck	7.1.18.4	37
Figure 50	Handrail fixing on upstand formed in concrete roofs	7.1.18.4	37
Figure 51	Base of balustrade post raised above drainage level	7.1.18.4	37
Figure 52	Balustrade post fixed to wall below coping/kerb	7.1.18.4	37

Definitions for this chapter

For the purposes of this chapter, the following definitions apply:

Air and vapour control layer (AVCL)	Continuous layer of impermeable material to prevent the movement of air and water vapour.
Balcony	<p>Accessible external amenity platform over an open space above ground level, with direct access from a building</p> <p>Balconies may take the form of:</p> <ul style="list-style-type: none"> • access balcony — providing pedestrian access to two or more dwellings (sometimes referred to as a 'walkway' or 'access deck') • enclosed — protected from rain by a roof or balcony above and walls or weather screens to the sides (sometimes referred to as a 'winter garden') • freestanding — fully, or partially, supported independent of the building structure • inset — recessed inwards from the external wall line of a building • open — has guarding but no other form of vertical enclosure • projecting — cantilevered from the external wall line of a building.
Biodiverse (brown) roof	Surface often of rubble or site-excavated soil, sometimes with the inclusion of logs and rocks, etc to replicate the ecology of the local area, and seeded or left to self-seed.
Blue roof	Roof installation designed for temporary attenuation of rainwater to delay entry into the urban drainage system and prevent flooding (Blue Roofs are not for water storage use).
Cold roof	Insulation below the deck with a ventilated void between the deck and breather membrane, supported on the insulation.
Deck	The structural substrate, including timber boarding or sheeting, profiled metal sheeting on joists/purlins, or the upper surface of in-situ or precast concrete and any applied screed.
Design fall	The fall that a roof should be designed at to accommodate initial and long-term deflection and achieve at least the required 'finished fall' in use (the design fall is normally taken as twice the finished fall).
Finished fall	The minimum fall that should be achieved on the waterproofing layer once the roof has been installed and fully loaded.
Firring	A tapered batten which creates a fall to a timber deck.
Flat roof	A roof with a maximum slope of 10 degrees from the horizontal.
Flat roof build-up	The roof components above the deck, including as applicable, AVCL, insulation, waterproofing layer and surface finish/topping.
Fully supported hard metal roofing	Flat hard metal sheeting forming the weather skin and fully supported on a deck.
Fully supported soft metal roofing	Soft metal sheeting (lead) forming the weather skin and fully supported on a deck.
Green Roof — extensive	Roof topping of a shallow growing medium supporting plants such as sedums, grasses, wildflower species, etc; generally low maintenance and access for maintenance only.
Green Roof — intensive	Roof topping of a growing medium to support trees, shrubs, lawns, etc; may include hard landscaping and be used as an amenity space (sometimes referred to as a 'roof garden').
Interstitial condensation	Condensation that occurs within or between layers of construction.
Inverted warm roof	A roof with insulation placed directly above the waterproofing layer.
Paving/decking	A protection layer on which people walk, above the waterproofing layer, on a balcony or terrace.
Profiled self-supporting metal deck	Profiled metal deck, spanning between structural supports, eg purlins and supporting the flat roof build-up.
Profiled self-supporting metal roofing	Profiled metal sheeting forming the weather skin and spanning between structural supports, eg purlins.
Terrace	<p>External surface for amenity use, above an internal space, above ground level and with direct access from a building (treated as a flat roof for waterproofing and thermal purposes).</p> <p>Terraces may take the form of:</p> <ul style="list-style-type: none"> • access terrace — providing pedestrian access to two or more dwellings (sometimes referred to as a 'walkway' or 'access deck') • buried podium — a roof structure at, or below, ground level with hard and/or soft landscaping and sometimes vehicular access for emergency vehicles or parking; waterproofing to the podium is linked to the tanking of the basement structure below, as described in Chapter 5.4 Waterproofing of basements and other below ground structures • private terrace — for the use of a single dwelling • raised podium — a terrace, other than an access terrace, above ground level, over a non-habitable area(s) such as a car park or plant room(s); the podium itself may provide hard and/or soft landscaped amenity areas.

Upstand	Perimeter waterproofing to provide continuity between a flat roof or deck and adjoining vertical wall construction (the minimum upstand height is normally 150mm unless serving an accessible threshold where this height may be reduced to 75mm).
Warm roof	A roof with insulation placed directly below the waterproofing layer.
Water flow reducing layer (WFRL)	A vapour permeable loose laid layer, resistant to water, UV and rot, used to reduce the flow of water and fines into the insulation layer in an inverted warm roof system.
Waterproofing layer	Layer of impermeable flexible material forming the primary barrier to water ingress.
Zero fall roof	A roof with a finished slope which lies between 0 and 1:80 and which achieves a finished drained surface that has no back falls or ponding this definition remains relevant to flat roof design and is currently recognised by the flat roofing industry.

7.1.1 Compliance

Also see: Chapter 2.1

Flat roofs, terraces and balconies shall comply with the Technical Requirements.

Flat roofs, terraces and balconies which comply with the guidance in this chapter will generally be acceptable to NHBC.

Other sources of information include:

- BS 6229 Flat roofs with continuously supported flexible waterproof coverings. Code of practice
- BS 8579 Guide to the design of balconies and terraces
- BS 8217 Reinforced bitumen membranes for roofing. Code of practice
- BS 8218 Code of practice for mastic asphalt roofing
- BS 8747 Reinforced bitumen membranes for roofing
- BS 5250 Code of practice for control of condensation in buildings
- BS 5427 Code of practice for the use of profiled sheet for roof and wall cladding on buildings
- BS 6915 Design and construction of fully supported lead sheet roof and wall coverings. Code of practice
- BS EN 507 Roofing products from metal sheet — Specification for fully supported roofing products of aluminium sheet
- BS EN 1090-4 Execution of steel structures and aluminium structures. Technical Requirements for cold-formed structural steel elements and cold-formed structures for roof, ceiling, floor and wall applications
- BS EN 12056 Gravity Drainage Systems inside buildings. Part 3 Roof drainage, layout and calculation
- BS 8490 Guide to siphonic roof drainage systems
- BS 8204 Screeds, bases and in situ floorings
- CIRIA C753 SuDS Manual 2015
- National Federation of Roofing Contractors (NFRC) — eg NFRC Technical Guidance Note for Construction and Design of Blue Roofs. Roofs and podiums with controlled temporary water attenuation
- Mastic Asphalt Council (MAC) Mastic asphalt — The technical guide
- Single Ply Roofing Association (SPRA) Single Ply: Design Guide
- Federation of Traditional Metal Roofing Contractors (FTMRC) 'UK Guide to Good Practice — 3rd edition'
- Lead Contractors Association 'Lead Sheet in Roofing. The Ultimate Guide to Best Practice'
- Lead Sheet Training Academy 'The complete manual'
- The GRO Green Roof code of practice for the UK
- The Green Roof Organisation GRO fire risk guidance document
- Liquid Roofing and Waterproofing Association (LRWA) Code of Practice Specification and Use of Liquid Applied Waterproofing systems for Roofs, Balconies and Walkways
- Siphonic Roof Drainage Association (SRDA) A guide to Siphonic Roof Drainage
- Metal Cladding and Roofing Manufacturers Association (MCRMA).

Where a flat roof or terrace is above another home, it should provide satisfactory acoustic performance in accordance with relevant Building Regulations.

Where applicable, flat roofs, balconies and terraces should meet the relevant fire protection requirements in accordance with relevant Building Regulations.

7.1.2 Provision of information

Designs and specifications shall be produced in a clear understandable format, include all relevant information and be distributed to all appropriate personnel.

Design and specification information should be issued to NHBC, site supervisors, relevant specialist subcontractors and suppliers, and include the following information.

- design and details for balcony construction, including the decking and drainage system
- extent and direction of falls, and position of outlets to provide effective drainage with no back falls (a roof deflection analysis should be provided for medium to large roofs and those with complex roof layouts)
- sections through the construction, including how falls are formed
- method of ventilating voids where ventilation is required
- size, specification and position of the components, including treatment for durability, and position and extent of the AVCL, insulation and waterproofing layers
- details at critical junctions
- details of fixings, their frequency and fixing method, including those for insulation and surfacing
- specification for intensive and extensive Green Roofs, biodiverse roofs or Blue Roofs
- details and fixing methods of balcony support and guarding components
- survey requirements and preparation treatment of deck before application of waterproofing
- method of testing the integrity of the waterproofing layer.

7.1.3 Flat roof, terrace and balcony general design

The flat roof, terrace and balcony construction should suit the design and intended use.

The design of the flat roof, terrace (including podium or balcony) should adopt one or more of the following forms of construction.

Note
The suitability of any combination of deck, insulation, Blue Roof attenuation and roof toppings will depend on the structural loadings and the capability of the deck and insulation to safely support those loads in accordance with the structural engineer's design.

Figure 1: Individual reinforced concrete (RC) elements

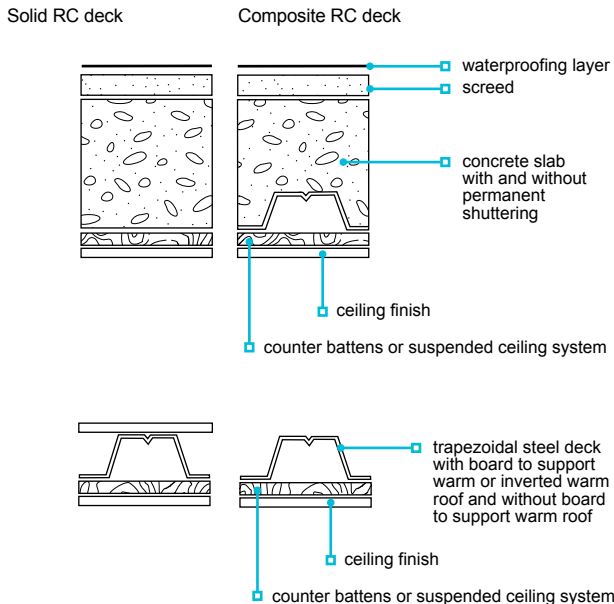

Figure 4: Inverted warm roof

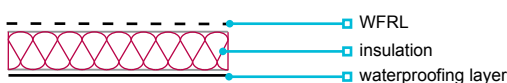

Figure 2: Warm roof



Figure 3: Cold roof

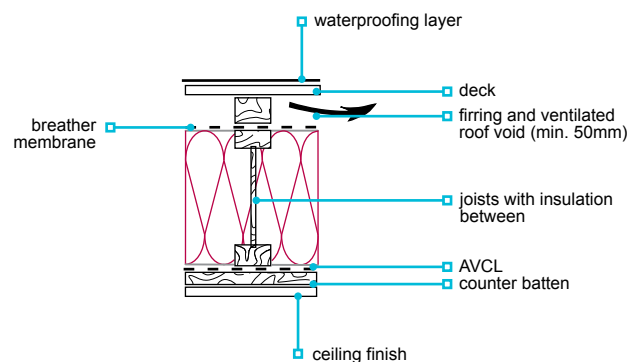

Figure 5: Uninsulated roof deck construction

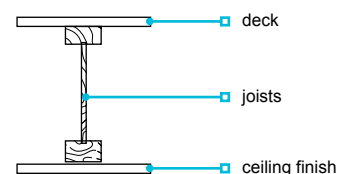

Figure 6: Roof toppings

Green Roof

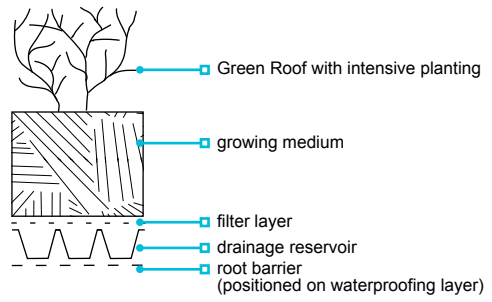
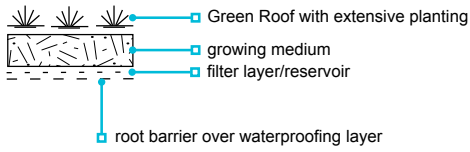
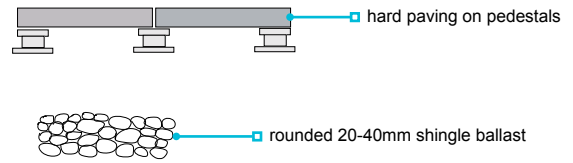
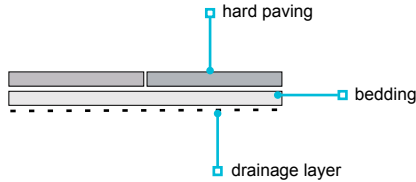

Figure 7: Paving



Roof, terrace and balcony constructions using the individual elements

Figure 8: Uninsulated decks

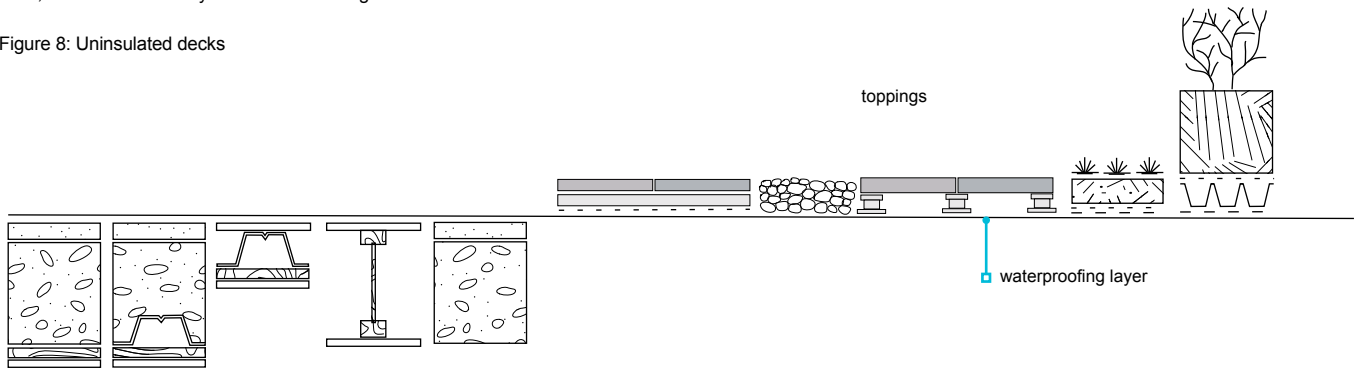

Figure 9: Warm roof construction

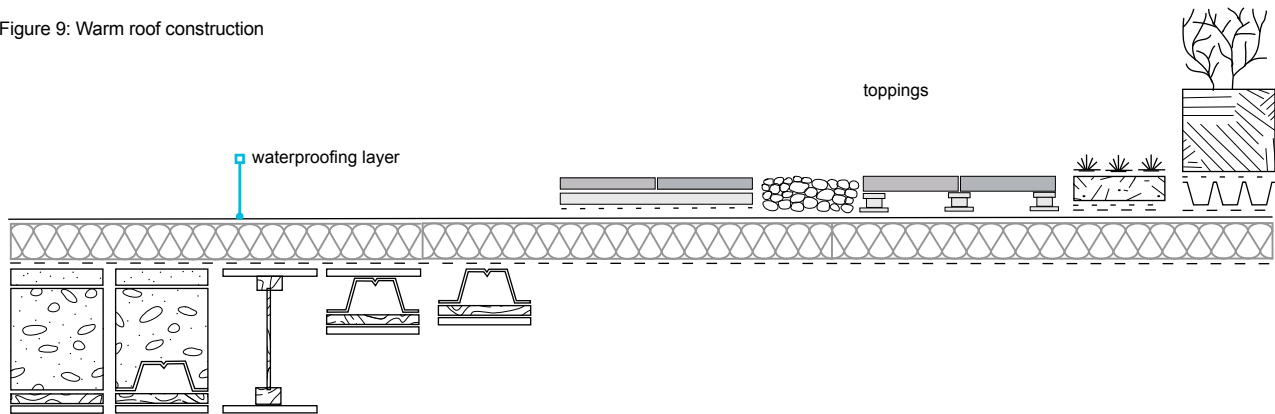

Figure 10: Inverted warm roof construction

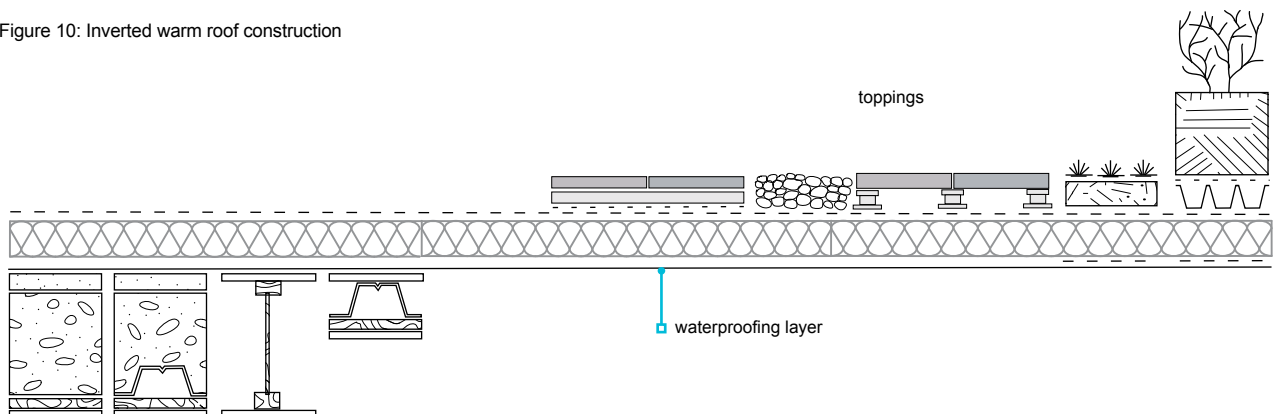

Figure 11: Cold roof construction

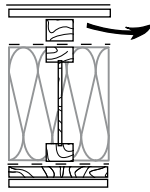
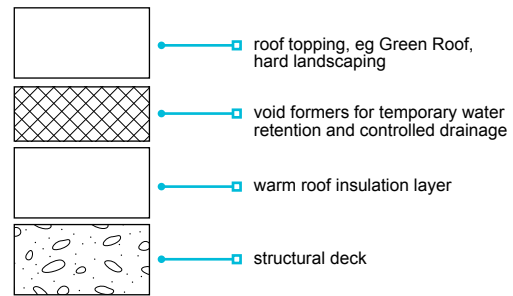

Figure 12: Blue Roof make-up



7.1.4 Drainage

Flat roofs, balconies and terraces shall have adequate and effective rainwater drainage to a suitable outfall. Design issues to be considered include:

- 1) drainage system
- 2) falls
- 3) zero fall roofs
- 4) deck survey.

7.1.4.1 Drainage system

The rainwater drainage system may be based on conventional piped drainage or an edge drained design. In all cases, the downpipes, overflows and edge drainage outlets should be positioned in the construction to provide effective drainage that will not cause water to flow directly down onto the walls and fascia surfaces below, or barrier edges of balconies installed in any stacked multi-storey arrangement.

A drainage system of outlets and downpipes should be:

- provided to all flat roof, balcony and terrace areas
- of sufficient size to accommodate normal rainfall and sized to cope with concentrated flows, including the accumulative effect of one roof draining onto another
- fixed in accordance with the design
- supported and jointed in accordance with the manufacturer's recommendations
- installed ensuring any gutters, including box gutters, are provided with stop ends where applicable, and with sufficient falls to provide effective drainage to outlets/downpipes
- provided with overflow(s) to avoid flooding in the event of one or more drainage outlets becoming blocked
- designed with a projecting profile that prevents rainwater from either tracking back into any soffit or running straight down onto vertical surfaces below
- designed with a downpipe shoe fitted where any downpipe outlet discharges above finished ground level, including above a drainage gulley.

Designs for drainage of balconies and terraces should follow BS 8579 guidance for the provision of discharge outlets with effective clearance, capacity and profile shape to throw rainwater clear of the edge and prevent residual dripping onto other parts of the building beneath.

A design approach for free draining balconies can be accepted if rainwater will always be routed away from the building to drain via a suitably formed soffit drainage tray that directs water to run outwards over a continuous formed perimeter edge. But where this drainage design is installed for stacked balconies on multi-storey elevations, the rainwater will tend to cascade down from these edge drainage slots as water runs off each balcony.

Under typical wind-driven rainstorm conditions, the water runoff volumes from these balcony catchment surfaces will progressively increase in a downward direction until the full volume of water reaches ground level. This can adversely affect locations such as main entrances to apartment buildings, as well as any access doorways and private gardens of individual homes at ground level. Therefore, in addition to the free draining balcony design, there is a requirement for design of ground level drainage to effectively prevent ponding or flooding of water. This drainage design is required along all building perimeter locations where thresholds, access locations and other places of regular use will exist.

Rainwater outlets should:

- be of the size and number required to deal with the expected rainfall intensity in accordance with BS EN 12056-3
- be positioned to provide effective drainage to all areas of the roof
- be recessed to facilitate the free flow of water without forming ponding at the junction with the waterproofing layer
- be accessible for maintenance
- be insulated to avoid surface condensation on the outlet and downpipe if passing through habitable areas.

Where a flat roof, balcony or terrace has an upstand on all sides, drainage should consist of a minimum of two outlets connected to separate downpipes, or be one outlet plus an overflow.

The overflow should be:

- provided through parapet walls or perimeter upstands
- sized for effective flow-rate and positioned to prevent water from entering the building, particularly in relation to door thresholds and low windowsills
- of higher capacity than the combined capacity of the other outlet(s)
- positioned to discharge safely away from the building
- always visible when in operation.

7.1.4.2 Falls

The finished roof, balcony or terrace should have effective drainage to the outlet(s) without creating back falls or ponding on the waterproofing layer and WFRL where fitted.

For large, medium and complex roof layouts a detailed analysis should be undertaken to establish both overall and localised deflections under predicted loading conditions, including long-term creep. This analysis should be co-ordinated with design for effective falls to roof drainage outlets. Allowances should be included for workmanship and construction tolerances, particularly with steel frame erection tolerances. The effects of localised loadings from features such as planters, service equipment, etc should be included in the design.

The design should show how ponding will be avoided, eg by placing outlets at points of maximum deflection, by use of a screed or tapered insulation, or firings, to take out the deflection and form falls to outlets.

Where falls are formed by use of screeds, follow the guidance in Clause 7.1.7.

Where tapered insulation is used:

- drainage should be designed by the insulation manufacturer, with design falls of no less than 1:60
- installation should comply with the design and manufacturer's recommendations
- the sequence of installation should ensure that boards are waterproofed and the roof sealed at the end of each day, or before the arrival of inclement weather
- it should be installed directly onto the AVCL, with the primary waterproofing layer above
- changes in the direction of falls should be formed with mitred joints
- successive roof layers should be installed with a minimum of delay, to avoid trapping water during construction.

Firring pieces should be:

- used to form falls, unless the design specifies a sloping joist or ceiling
- of the size given in Table 1 where installed across the joists
- adequately fixed to the joists in accordance with the design.

Table 1: Size of firring pieces used to form falls

Joist centres (mm)	Minimum width (mm)	Minimum depth (mm)
400 or 450	38	38
600	38	50

Figure 13: Firrings used to form deck fall gradient

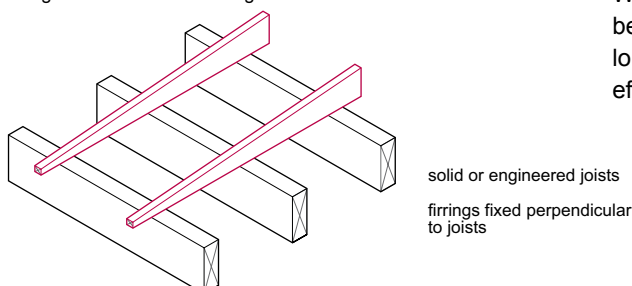

Where a detailed analysis is not undertaken, the roof should be designed with a design fall that caters for initial and long-term deflection to ensure the finished fall provides effective drainage without back falls or ponding.

Table 2: Suggested design falls for various roof types

Type of roof	Design fall	Minimum finished fall
Membrane and liquid applied waterproofing	1:40 ⁽³⁾	1:80
Profiled metal roof system (self-supporting)	5.5° (1:10) ⁽¹⁾	4° (1:14) ⁽²⁾
Profiled metal roof (fully supported)	6.5° (1:9)	5° (1:12) ⁽⁴⁾
Standing seam roof system (self-supporting)	2.5° (1:23) ⁽¹⁾	1° (1:60) ⁽⁴⁾
Flat sheet hard metal roof (fully supported)	1:40 ⁽³⁾	5° (1:12) ⁽⁴⁾
Lead roof (fully supported)	1:40 ⁽³⁾	1:80
Green/biodiverse roof	1:40 ⁽³⁾	1:80 (at drainage level)
Blue Roof	1:40 ⁽³⁾	1:80 (Also see Clause 7.1.13)
Tapered insulation	1:60 ⁽³⁾	1:80

Notes

1. The supporting structure should be designed at a pitch of 1.5° more than the minimum pitch for the sheeting, or the designed roof slope, to allow for tolerances and on-site variations, unless justified by a detailed structural analysis of the main frame and secondary steelwork to account for deflection/settlement.
2. Based on through fixings. For lesser pitches, including the apex of any curved roof which approaches flat, proprietary secret fixed types of profiled sheeting should be used in accordance with the system manufacturer's instructions.
3. Design fall to take account of deflection and construction tolerance for the supporting deck to ensure at least minimum finished fall on completed roof. Design fall is usually taken as twice the finished fall unless a detailed deflection/settlement of the deck is carried out.
4. Check with manufacturer for alternative pitch recommendations.

7.1.4.3 Zero fall roofs

Zero falls are not accepted for roofs with exposed waterproofing layers; such roofs should be designed to the falls shown in Table 2.

7.1.4.4 Deck survey

Prior to laying the waterproofing layer(s), a site survey of the deck should be carried out by the deck erector, and any backfalls should be rectified. Depending on the deck construction material, this may be achieved by applying localised screed, to remove depressions and maintain falls to outlets, these remediated areas should be resurveyed to ensure no backfalls remain. Additional rainwater outlets may be required at any remaining point(s) of maximum deflection. A formal handover procedure should be undertaken between the deck erector and a specialist waterproofing contractor.

7.1.5 Flat roof, terrace and balcony structural design

Flat roofs, terraces and balconies shall support and transmit loads safely to the structure.

The structure of the flat roof, terrace or balcony should:

- be produced by an engineer in accordance with Technical Requirement R5, and BS EN 1991-1-1, BS EN 1991-1-3, BS EN 1991-1-4 and BS 8579: 2020 for balconies
- be designed to address both short-term and long-term deflection to provide an effective drainage strategy with no back falls or ponding
- resist wind uplift by self-weight or by being anchored to the main structure — where required, holding-down straps should be provided at maximum 2m centres at the perimeters
- have adequate provision for additional loads where a flat roof is to act as a terrace, roof garden, for support of permanent service equipment, and for additional loads during construction
- have adequate provision for movement in larger roofs, particularly where the span of the roof deck changes (in L-shaped buildings; joints should be continuous through the vertical upstands, walls and edges of the building)
- include support steelwork and joists which are square, true and free from twists or sagging
- have adequate crack control/dimensional stability to avoid damage to directly applied AVCL and waterproofing layers, particularly for liquid applied waterproofing.

Where joists and concrete roof elements are used to provide lateral restraint, they should:

- have a minimum bearing of 90mm, or
- have restraint straps at 2m centres (maximum) where joists or concrete beams are parallel to walls.

7.1.6 Timber structure and deck

Timber flat roofs, balconies and terraces shall be of adequate strength and durability and be installed to form a satisfactory substrate for the waterproofing system. Issues to be considered include:

- 1) structure and durability
- 2) joist hangers, straps and strutting
- 3) installing timber decks.

7.1.6.1 Structure and durability

Structural elements of balconies should have a service life of at least 60 years.

Timber in balconies should be limited to elements which are supported by materials other than timber. Timber should not be used for:

- gallows brackets supporting a balcony
- posts or columns supporting a balcony
- guardrails, including their support
- infill joists
- cantilevered joists or decks.

Decking boards should be specified and fixed in accordance with:

- guidance from the Timber Decking and Cladding Association (TDCA), or
- an engineer's design, in accordance with Technical Requirement R5.

The use of timber in balcony and terrace constructions may also be restricted by fire protection requirements set out in the Building Regulations.

Timber, including solid and engineered joists, should be:

- checked for conformity with the design upon delivery
- rejected where excessively wet, damaged or not of a suitable quality or shape
- stored under cover to prevent wetting but avoid sweating
- preservative treated or naturally durable, in accordance with Chapter 3.3 Timber preservation (natural solid timber)
- re-treated along the cut edges with a coloured preservative, where preservative treated timber has been cut
- be temporarily covered to prevent wetting, unless the waterproofing is to be installed immediately.

Timber structure should:

- be in accordance BS EN 1995-1-1 or appropriate load/span table published by TRADA in support of Building Regulations
- be from regularised timber, dry graded to BS 4978 and marked 'DRY' or 'KD' where softwood is used internally
- have I-joists or metal web joists specified in accordance with the manufacturer's recommendations and not used where any part of the joists is exposed to external conditions
- have joists which are sized and spaced in accordance with the design and at maximum 600mm centres
- be level and, where necessary, using hard packing such as tiles or slates bedded in mortar to adjust joists (loose or soft packing, including timber, should not be used).

Timber decks should be formed from one of the materials listed in Tables 3, 4 and 5.

Table 3: Materials used for deck to flexible membrane roof coverings

Material	Minimum thickness of deck (mm) ⁽¹⁾	
	450mm joist centres	600mm joist centres
Plywood board to BS EN 636, Use Class 3.2, 'S' ⁽²⁾	15 ⁽⁴⁾	18 ⁽⁴⁾
Oriented strand board, to BS EN 300 type OSB3	15	18
Pre-treated timber planking, tongue and grooved (close boarded timber; maximum plank width 100mm ⁽³⁾)	19	19

Notes

1. Deck may need to be thicker to resist pull-out forces on fixings.
2. All square board edges to be supported.
3. Moisture content between 16-20% at time of fixing.
4. For curved roofs, two layers of thinner boards to achieve minimum thickness.

Table 4: Decking materials for fully supported traditional hard metal roof coverings

Material	Minimum thickness of deck (mm)
Plywood board to BS EN 636, Class 3.2, 'S' ⁽¹⁾ square edged with 2-3mm gaps between boards ⁽³⁾	18 ⁽²⁾
Pre-treated timber square edged sarking boards, width 100-125mm with 3-5mm gaps between ⁽⁴⁾	18

Notes

1. Avoid yellow and maritime pine or low-quality softwoods.
2. For curved roofs, two layers of thinner boards to achieve minimum 18mm thickness.
3. All board edges to be supported.
4. Moisture content between 16-20% at time of fixing.

Table 5: Decking materials for lead roof coverings

Material	Minimum thickness of deck (mm)
Plywood board to BS EN 636, Class 3.2 'S' ⁽¹⁾ square edged with 3-5mm gaps between boards ⁽³⁾	18 ⁽²⁾
Pre-treated softwood timber square edged sarking boards, width 100-125mm with 2-3mm gaps between ⁽⁴⁾	18

Notes

1. Avoid oak, Douglas fir and Western red cedar.
2. For curved roofs, two layers of thinner boards to achieve minimum 18mm thickness.
3. All board edges to be supported.
4. Moisture content between 16-20% at time of fixing.

7.1.6.2 Joists hangers, straps and strutting

Masonry carrying joist hangers should be level and at the correct height.

Mild steel straps and fixings should be protected against corrosion in accordance with BS EN 845-1.

Joist hangers should be:

- in accordance with BS EN 845
- the correct size for the timber joist or trimmer
- fixed in accordance with the design.

Where holding-down straps are required to prevent the roof from lifting from the supporting structural, they should be:

- spaced at a maximum of 2m centres at the perimeters
- fixed with minimum of four hardened nails 4mm in diameter x 75mm long, or No. 12 wood screws x 50mm long, into plugs (where fixed to masonry)
- fixed with the lowest fixing secured within 150mm of the bottom of the vertical strap
- 30mm x 2.5mm and 1m long
- predrilled for fixings.

Figure 14: Joist hanger

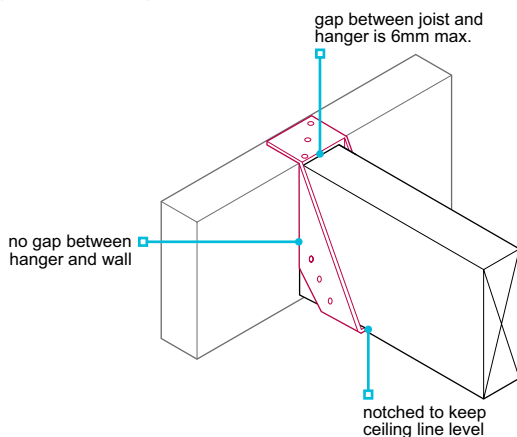
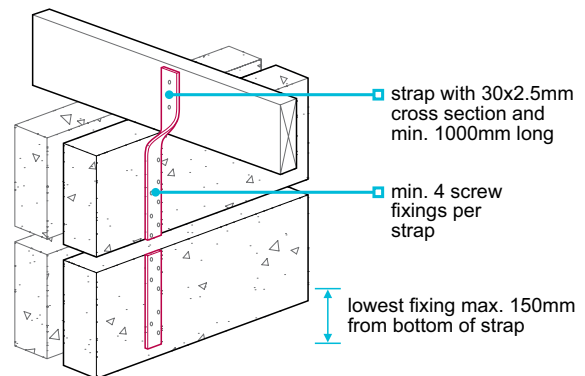

Figure 15: Joist strap



Strutting should be provided to prevent excessive movement, and:

- be either herringbone type (timber 38mm x 38mm), solid blocking (38mm thick timber x 0.75 depth of joist) or proprietary steel strutting or I-joist sections
- not prevent cross ventilation in cold roofs
- be spaced in accordance with Table 6.

Table 6: Spacing for strutting

Joist span (m)	Rows of strutting
Up to 2.5	None needed
2.5 – 4.5	One (at centre of span)
Over 4.5	Equally spaced along the span at maximum 2.5m centres

7.1.6.3 Installing timber decks

When installing timber decks:

- conditions should be dry, and materials protected from wetting until the roof is complete
- the area of deck installed should be of a size which can be quickly covered in the event of rain
- materials that have been damaged or adversely affected by moisture should be discarded
- tops of boards should be laid flush, with no deviation greater than 2mm
- boards should be laid in a staggered pattern
- cut edges should be treated to prevent moisture ingress
- boards should have a minimum 'good one side'
- boards should have all nails and screws punched or countersunk below the surface of the board
- boards should be free of sharp arises on external angles.

Plywood and oriented strand board (OSB) should:

- have tongued and grooved boards installed with the long edges at right angles to the supporting firrings or joists, and short edges supported on a joist or noggling (always use square edge boards for support of hard metal and lead roofs)
- have edges of square edged boards supported on joists or noggings with movement gaps of 3-5mm between boards
- have a minimum movement gap of 10mm (or 2mm per metre of boarding, whichever is the greater) where boards abut a rigid upstand
- be supported on noggings where the edges of boards situated along the roof perimeter do not coincide with joists, and where square edged boards within the roof area do not coincide with a joist
- be fixed at a maximum of 100mm centres (unless the design specifies closer)
- be fixed with flat-headed ring shank nails (minimum of 50mm long x 3mm for plywood, or for OSB, a 3mm gauge nail size of minimum length 2.5 x board thickness. For woodscrew fixings, the same minimum lengths will apply.

OSB should be:

- installed over supports in the direction indicated on the boards, with the stronger axis installed at right angles to the supporting joists
- fixed a minimum of 8mm from the edge of the board.

Figure 16: Softwood tongued and grooved boarding

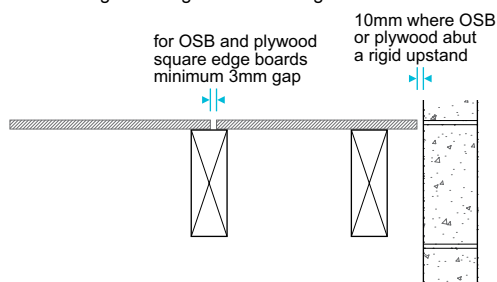

Softwood tongued and grooved boarding should be:

- closely clamped together with end joints staggered
- fixed with two ring shank nails to each joist or furring, with nail heads punched below the timber surface.

Cross Laminated Timber (CLT)

Due to the semi-impervious nature of CLT panels and the risk of trapping moisture in the panels during the construction period, they are not accepted for flat roof construction.

Structural insulated panels systems (SIPS) (used as self-supported deck)

Due to the difficulty in achieving effective continuity of an AVCL across the warm side of a SIPS deck construction, and the risk of trapping moisture in these panel assemblies during the construction period, SIPS elements are not accepted for warm flat roof construction.

7.1.7 Concrete decks

Concrete flat roofs and balconies shall form a satisfactory substrate for the waterproofing systems. Issues to be considered include:

- 1) structure and durability
- 2) screeds to falls
- 3) drying.

7.1.7.1 Structure and durability

Concrete flat roofs should be constructed to ensure they achieve the required design, strength and durability, and be in accordance with BS EN 1992-1-1 and Chapter 3.1 Concrete and its reinforcement.

In-situ reinforced concrete decks should:

- be formed using a mix which has low shrinkage characteristics
- have accurately constructed and suitably supported formwork
- have an even surface to receive the selected waterproofing layer (with adhesive bonded membranes; the surface should be slightly roughened, wooden floated or lightly brushed, in accordance with the manufacturer's recommendations)
- be protected until adequately cured and dried
- not contain additives that could affect the adhesion of any adhesive bonded waterproofing membranes.

Note

Liquid applied surface treatment onto the concrete to assist curing can adversely affect the bonding of the waterproofing layer. The compatibility of such liquids should be checked with the waterproofing layer manufacturer before use.

Precast concrete decks should:

- have a minimum 90mm bearing (unless the design specifies a smaller dimension)
- have allowance for continuity or anti-crack reinforcement to avoid differential movement between units and stress in the waterproofing layer
- have allowance for movement approximately every 15m and at abutments
- be installed to provide an even surface with no back falls
- be grouted, as specified in the design.

7.1.7.2 Screeds to falls

Where falls have not been formed in the concrete deck, they may be formed by the application of a screed. Sand/cement screeds used to form falls to concrete roofs should be:

- free from ridges and indentations
- laid on a concrete deck that has been suitably prepared to receive a screed
- finished with a wooden float to provide a smooth, even surface for the AVCL and waterproofing finish
- to a minimum thickness in Table 7 where a cement/sand screed 1:4 (cement:sand) is used
- suitably dry and primed to receive the waterproofing system in accordance with the membrane manufacturer's recommendations.

Lightweight screed should only be installed by specialist contractors and have a topping of 1:6 (cement:sand) 15mm thick.

Table 7: Minimum screed thicknesses

Location of screed	Nominal thickness (mm)
Bonded monolithically in-situ or separately bonded to precast concrete ⁽¹⁾	40 (25 minimum)
Unbonded on separating layer	70 (50 minimum)
Proprietary polymer modified screeds	In accordance with manufacturer's recommendations

Notes

1. Precast units should be sufficiently rigid and properly grouted to avoid movement between units leading to cracking in the bonded screed. Movement joints/details may be required over ends of precast units and at perimeters or abutments. The waterproofing layer detailing should take account of any movement joints.
2. Where a cast in-situ concrete deck, designed and laid to falls, is found to have areas of ponding or back falls, preparation work should be carried out to provide effective drainage prior to the application of the waterproofing layer. Polymer modified screeds may be used to make up any depressions in the concrete roof to avoid any ponding or correct any back falls. The adjusted areas should be resurveyed to ensure no ponding or back falls remain. The compatibility of the levelling screed with the waterproofing layer should be confirmed by the waterproofing manufacturer.

7.1.7.3 Drying

A permanent waterproofing layer should not be installed until the deck has cured and dried sufficiently to avoid trapping potentially damaging moisture and to allow the application of the waterproofing in accordance with the membrane manufacturer's recommendations. A check should be carried out on the moisture content of the slab to meet the membrane manufacturer's recommendations. Where an adhesively bonded waterproofing layer is to be applied, a bond test should be undertaken to check whether the concrete is sufficiently dry to achieve effective bonding adhesion. This is usually around 28 days for fully bonded waterproofing, or to the manufacturer's recommendations.

Note
Permanent metal shuttering will significantly prolong the period needed to achieve an acceptable moisture content of the concrete before applying any waterproofing layer. Perforated shuttering can assist drying out; any perforation should be factory made. A mechanical extraction/dehumidifier can also assist in the drying process.

7.1.8 Profiled self-supporting metal roof decks

Profiled self-supporting metal decks shall form a satisfactory substrate for the flat roof build-up. Issues to be taken into account include:

- | | |
|---------------------------|-------------------|
| 1) structural performance | 3) roof build-up. |
| 2) material and profile | |

7.1.8.1 Structural performance

Profiled self-supporting metal flat roofs should:

- be constructed to ensure they achieve the required strength and durability, and be checked for conformity with the design upon delivery
- comply with the manufacturer's load and span tables including relevant applied safety factors
- conform to BS EN 1090-4 (steel) and BS EN 10905 (aluminium)
- resist loads in accordance with BS EN 1991-1-4
- be fixed in accordance with the manufacturer's instructions with side laps stitched to ensure performance as a continuous structural plane (unless a manufacturer and design specialist recommends otherwise)
- be adequately protected from construction loads
- be suitably stored to prevent damage.

7.1.8.2 Material and profile

Profiled self-supporting metal flat roof sheeting should:

- be galvanised steel to BS EN 10346 (typical gauge range 0.7-1.2mm) or aluminium to BS EN 485-2 (minimum gauge 0.9mm) and used in accordance with BS EN 1993-1-3 and BS EN 1999-1-4 respectively
- for bonded systems — have a crown which at least 45% of the profile width, not including the crown stiffener grooves
- for mechanically fixed systems — have a crown which at least 40% of the profile width, not including the crown stiffener grooves
- be of suitable quality and finish before the waterproofing layer and insulation system is installed
- be fixed using suitably specified fixings which avoid bimetallic corrosion in accordance with the manufacturer's recommendations.

7.1.8.3 Roof build-up

The roof build-up should:

- be a warm or inverted-warm roof design
- have drainage falls formed by installing the profiled metal sheeting fitted at a slope or by use of tapered insulation
- use an insulation board product with a compressive strength capable of spanning across the troughs of the profiled sheeting without crushing, or be laid over support boards fixed across the profiles
- in warm roof build-ups where unsupported across the troughs, use a reinforced AVCL, or AVCL recommended by the waterproofing manufacturer
- for inverted warm roof designs, these should incorporate support boarding fixed across profiles to fully support the waterproofing layer.

Figure 17: Profiled metal deck features

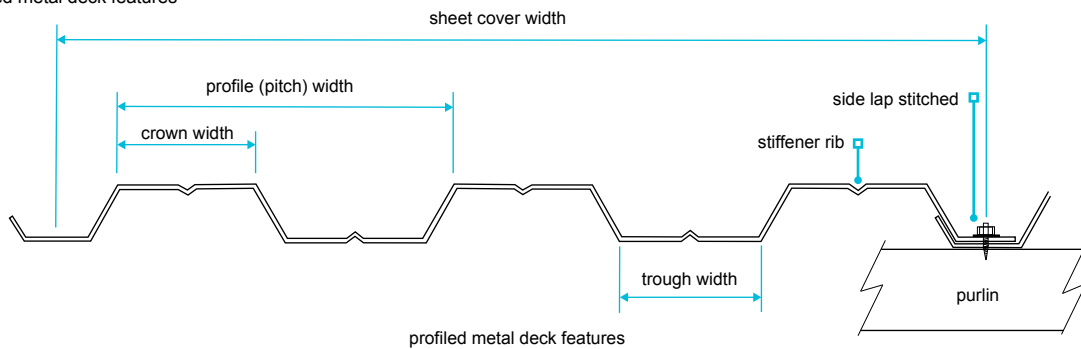

Figure 18: Warm roof construction — with metal deck

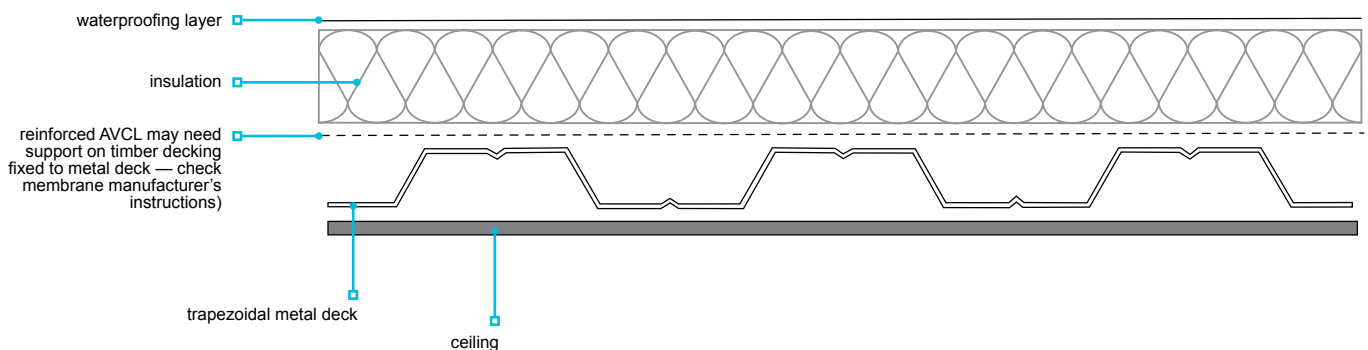
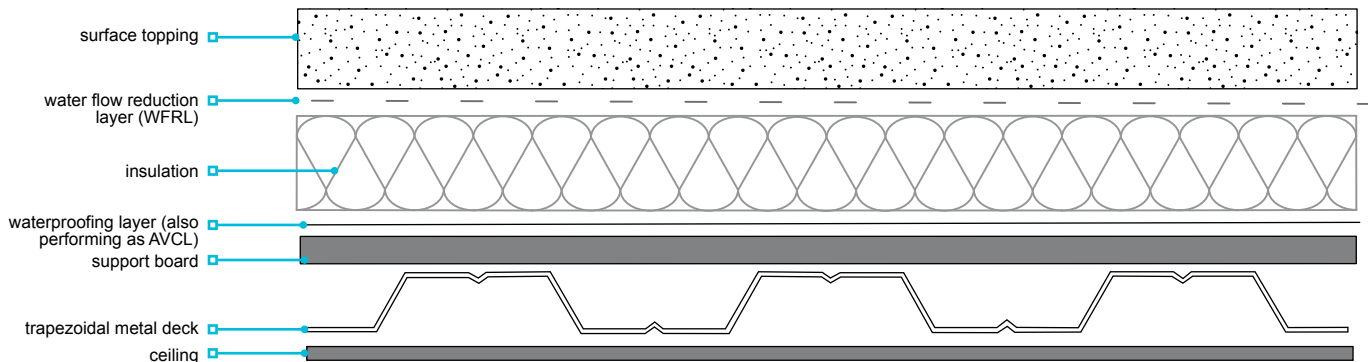

Figure 19: Inverted warm roof construction



7.1.9 Profiled self-supporting metal roofing

Profiled self-supporting metal roofing shall be of adequate strength and durability, resist the passage of water to the inside of the building, and provide an adequate level of thermal and sound insulation.

Profiled self-supporting metal sheet roofs should be designed and constructed in accordance with:

- BS 5427 Code of practice for the use of profiled sheet for roof and wall cladding on buildings
- BS EN 14782 Self-supporting metal sheet for roofing, external cladding and internal lining. Product specification and requirements
- BS EN 14509 Self-supporting double skin metal faced insulating panels — Factory made products — Specification
- BS EN 508 — Parts 1, 2 and 3 Roof and cladding products from metal sheet. Specification for self-supporting products of steel, aluminium or stainless steel
- BS EN 506, for self-supporting copper and zinc
- BS EN 1991-1-1, 3 and 4 for structural loads and be fixed in accordance with the manufacturer's instructions.

Profile sheet roofing can be:

- a site assembled system including self-supporting metal liner and outer metal profile. To be held apart by a site-installed structural support system, with insulation between the liner and profile layers
- factory insulated panels system ie, sandwich panels or composite panels with metal inner and outer skins factory bonded onto a thermal core insulation layer to form a composite self-supporting assembly.

An AVCL must be provided on the warm side of the insulation.

Note
Subject to the profile manufacturer's recommendations, the AVCL can be formed by sealing the side and end laps of the metal liner or by the provision of a separate AVCL membrane directly above the inner liner. The AVCL must be fully sealed around all penetrations and at the roof perimeter, and have a vapour resistance of at least 5,000MNs/g. If high-density polythene is used, it must be reinforced 1,000 gauge or more and of virgin material.

Insulation should contact both the inner and outer metal layers. Any voids formed by the profile of the outer sheet metal roof covering should be ventilated. Ventilation can be achieved by leaving open the profile at both ends of the sheeting above the insulation. If profile fillers are fitted, they should leave a free area of not less than 5% of the cross-sectional area of the void. Where the insulation is likely to be affected by local condensation, a breather membrane should be provided on top of the insulation to discharge condensate externally in accordance with the profile manufacturer's recommendations.

The profiled panels should be fixed using suitable fixings which avoid bimetallic corrosion in accordance with the manufacturer's recommendations.

Figure 20: Twin skin build-up

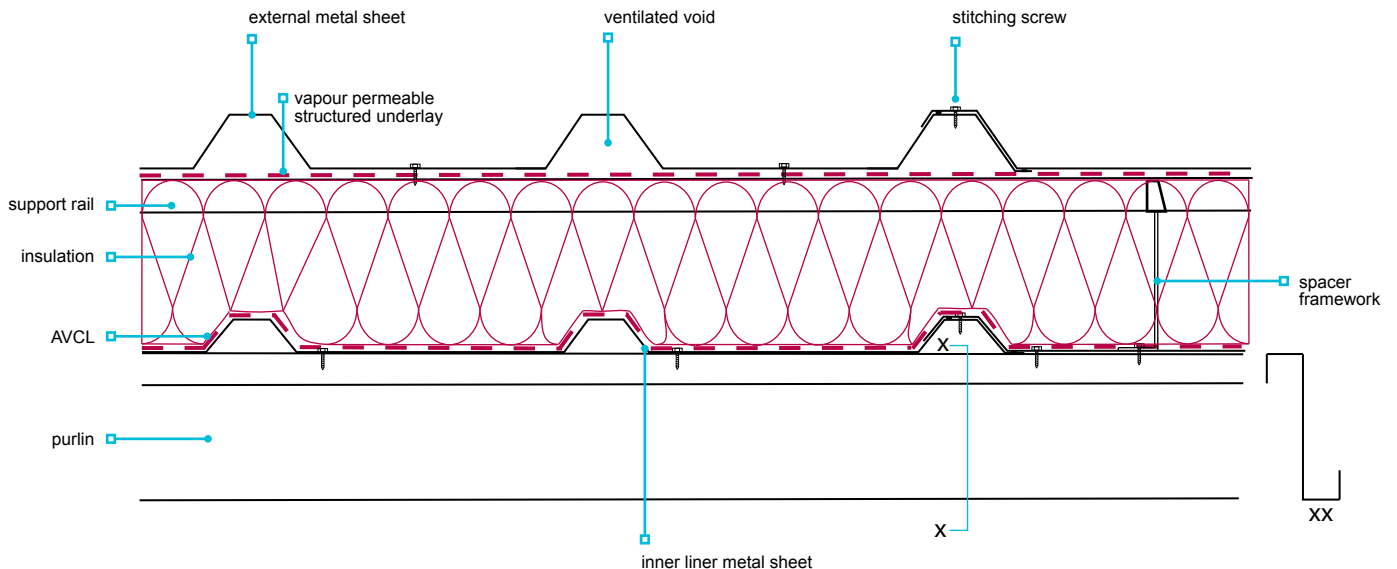

Figure 21: Standing seam roof (secret fixings)

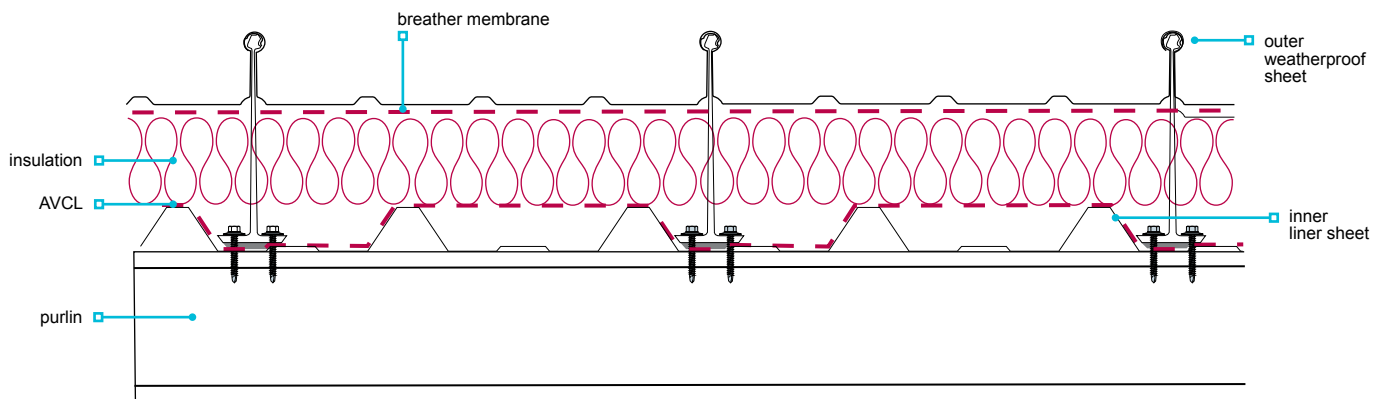
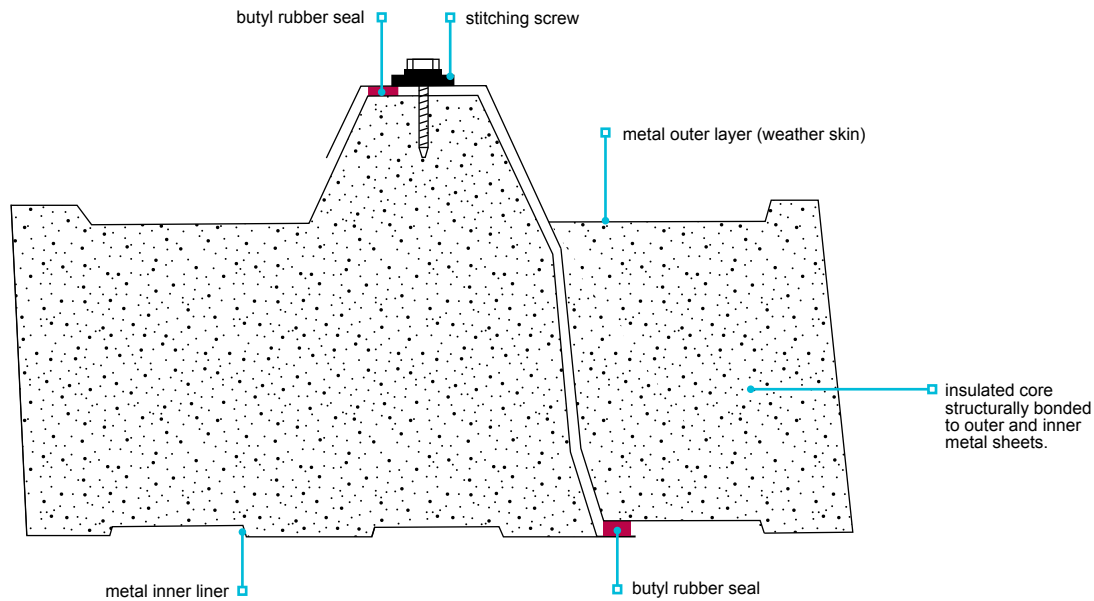

Figure 22: Example of edge seal with composite roof panels



The panel side laps and end laps should be sealed to provide an air barrier as part of the overall air leakage and vapour control requirement of the building, in accordance with the panel manufacturer's instructions.

7.1.10 Thermal insulation and vapour control

Also see: *BRE Report Thermal insulation: avoiding risks and BS 5250*

Thermal insulation, vapour control and ventilation shall ensure satisfactory performance, and prevent the formation of condensation which could adversely affect the construction. Issues to be considered include:

- 1) thermal characteristics of roof types
- 2) types of insulation
- 3) control of water vapour.

7.1.10.1 Thermal characteristics of roof types

Uninsulated roof — the temperature of the deck is at or close to that of the interior or exterior of the building, whichever is the lesser.

Cold roof — the temperature of the deck is at or close to that of the external climate. Cold roof designs should be limited to roofs where it can be shown that effective cross-ventilation can be provided to reduce the risk of interstitial condensation.

Warm roof — the temperature of the deck is at or close to that of the building interior.

Inverted warm roof — the temperature of the deck is at or close to that of the building interior. The WFRL should be designed and installed to collect and drain most of the rainwater to reduce water entering and cooling the insulation layer.

Condensation analysis should be calculated as given in the relevant clause of BS 6229 for Control of Condensation, in accordance with BS 5250 and BS EN ISO 13788.

7.1.10.2 Types of insulation

Types of insulation and their use should be in accordance with Table 8.

Table 8: Insulation materials — types and product standards

Insulation material	Abbreviation	BS EN Standard	Applications	
			Warm roof	Inverted warm roof ⁽¹⁾
Expanded polystyrene board	EPS	13163	yes ⁽²⁾	no ⁽³⁾
Extruded polystyrene board	XPS	13164	yes ⁽²⁾	yes
Rigid polyurethane foam board	PUR, or PU	13165	yes	no
Phenolic foam board	PF	13166	yes	no
Polyisocyanurate board	PIR	13165	yes	no
Cellular glass board	CG	13167	yes	no ⁽³⁾
Expanded perlite board	EPB	13169	yes	no
Cork board	ICB	13170	yes	no
Fibreboard, bitumen-impregnated (used in conjunction with EPS with hot applied waterproofing)			yes	no
Composite boards or decks (eg PIR insulation bonded to plywood)			yes	no
Resin bonded mineral wool rigid board	MW	13162	yes	no
Mineral wool quilts ⁽⁴⁾	MW	13162	no	no
Vacuum insulation panels ⁽⁵⁾	VIP		yes	yes

Notes

1. Thermal insulation used in inverted roofs should be designed in accordance with ETAG 031 Inverted Roof Insulation Kits Guideline for European Technical Approval.
2. Suitably protected when using hot applied waterproofing.
3. Unless the product has an independent third-party assessment for use in inverted warm roofs.
4. Not suitable for warm or inverted warm roofs and only used in cold roofs.
5. Suitably assessed in accordance with Technical Requirement R3.

Insulation for warm roofs should be:

- either:
 - bonded or mechanically fixed to resist wind uplift in accordance with the manufacturer’s recommendations; where mechanically fixed, it should be installed using fixings of sufficient length to ensure adequate penetration into the supporting structure, or
 - part of a loose laid roof system which is ballasted to resist wind uplift
- kept dry and installed in quantities which can be quickly covered if it rains (to aid bonding and to avoid trapping moisture)
- dimensionally stable at working temperatures (eg 100°C under metal roofs)
- lightly butted to avoid gaps.

Insulation for inverted roofs should be:

- extruded polystyrene (XPS), or expanded polystyrene (EPS) should be suitably assessed in accordance with Technical Requirement R3
- suitable for external use
- ballasted to avoid floatation and wind uplift
- suitable for the weight of the ballast and able to withstand anticipated traffic and design loads
- protected by a breathable water flow reducing layer WFRL to reduce the cooling effect of cold water flowing into and under the thermal insulation and across the waterproofing layer
- calculated to take account of the cooling effect of rainwater seeping through the insulation board joints in accordance with BS 6229 and ETAG 031-1 and the dry calculated thickness increased to allow for this cooling effect.

Note
A WFRL should be designed and installed to drain most of the water from the roof. It should be installed at right angles to the designed slope of the roof, starting at the bottom of the slope. All side and end laps should be a minimum of 300mm. The WFRL should be star cut around pipes and wrapped with an additional membrane section, turned up at upstands and penetrations, and turned down at drainage locations/outlets.

Composite insulated timber decks should:

- have two beads of sealant along each board joint at the foil under face (to maintain the integrity of the VCL) in accordance with the board manufacturer’s recommendations.

Figure 23: Composite insulated timber deck

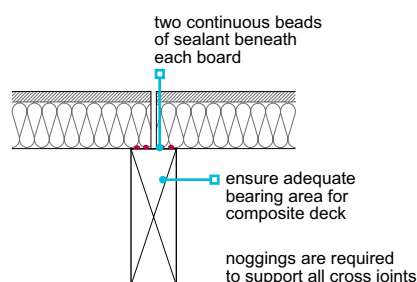

7.1.10.3 Control of water vapour

The movement of water vapour within the roof construction must be controlled to avoid the risk of interstitial condensation. This can be achieved by providing an AVCL on the warm side of the insulation.

In a cold roof, the addition of ventilation to the void(s) between the insulation and decking can also assist by removing water vapour from within the construction.

Warm roofs do not incorporate ventilation and rely entirely on the AVCL to avoid interstitial condensation. It is therefore essential that a good quality AVCL is used and that all laps, joints or penetrations are fully sealed. All AVCLs should be fully checked for any damage just prior to being covered over. Any damage should be repaired using a full width section of membrane. Penetrations should be kept to a minimum and fully sealed to the AVCL.

In an inverted warm roof, the waterproofing layer also acts as the AVCL. Control of interstitial condensation relies on the thermal insulation above the waterproofing layer being kept free from running or ponding water between the insulation and waterproofing layer, and within joints between the insulation boards. This should be controlled by the correct installation of the WFRL laid over the insulation.

AVCLs can be formed with one of the materials listed in Table 9.

Table 9: Materials for use as an AVCL

Material	Specification
Reinforced bitumen membranes	BS 8747 BS EN 13970
Self-adhesive polythene/metal foil/bitumen membranes for cold self-adhesion	BS EN 13970 BS EN 13984
High-density polyethylene sheet with metal foil core	BS EN 13984
High-density polyethylene sheet	BS EN 13984
Plastic and rubber sheets	BS EN 13984
12mm one coat mastic asphalt on glass fibre tissue	BS 6925

Note

Metal-cored flexible reinforced bitumen membranes are also suitable to form an AVCL.

AVCLs to warm roofs should:

- include at least one layer of reinforced bitumen roofing membrane (S2P3) below the insulation, fully or partially bonded to the structural deck as appropriate, or a suitable self-adhesive or torch-on membrane
- be self-sealing (eg self-adhesive aluminium foil-backed modified bitumen membrane) if penetrated by mechanical fixings, eg those securing the insulation boards to the deck
- be sealed and lapped to the waterproofing layer (where compatible) at the perimeters and at each penetration, eg at outlets and pipes, rooflights, etc or extended up a minimum 50mm above the insulation and sealed to the wall, rooflights, etc
- be fixed to resist the calculated wind uplift forces.

AVCLs for warm roof constructions supporting traditional hard metal roofs should have a minimum vapour resistance of 4000MNs/g and be fully supported.

Any fixings that penetrate the AVCL, eg those securing insulation boards to the deck, should be carefully installed to avoid creating open perforations that would allow water vapour to pass through.

Cold flat roofs are difficult to detail correctly but, where used, they should be in accordance with BS 6229 and BS 5250 and have:

- an effective AVCL at ceiling level
- an unobstructed minimum 50mm ventilation space above the insulation
- adequate cross ventilation (openings at both ends of each joist void equivalent to a minimum 25mm gap)
- a maximum clear distance of 5m between ventilators on opposite sides of the roof.

Note

All ventilation gaps should have protective mesh or grilles (nominal 4mm openings) to avoid entry of large insects and birds.

7.1.11 Waterproofing layer and surface treatments

Flat roofs, and balconies forming roofs, shall adequately resist the passage of water to the inside of the building. Issues to be considered include:

- | | |
|--|-----------------------|
| 1) installation of waterproofing layer | 3) surface treatments |
| 2) waterproofing systems | 4) fire protection. |

7.1.11.1 Installation of waterproofing layer

Prior to the waterproofing layer being installed:

- the surface should be even and dry, and any nails should be punched, or screws countersunk, below the surface
- any penetrations for drainage, services, rooflights, etc should be formed before the waterproofing layer is applied
- the manufacturer's recommendations for the preparation, including priming upstands, roof outlets, etc should be followed to achieve a satisfactory bond with the waterproofing layer
- the manufacturer's recommendations for conditioning, and unrolling membranes in advance of laying, should be followed.

Environmental conditions should be suitable for installing the waterproofing layer. Issues to be considered include the following:

- membranes should not be installed or handled when the product temperature and the air temperature is 5°C or less, unless otherwise agreed with the manufacturer
- self-adhesive bitumen membranes should not be installed or handled below 5°C, unless otherwise permitted by the manufacturer
- membranes should not be installed on damp or frosted surfaces, or when any rain, sleet or snow is falling.

Waterproofing layer should be:

- secured in a manner that resists the wind uplift
- secured in a manner that allows expansion of metal decks
- installed in accordance with the design and the manufacturer's recommendations
- installed by a specialist roofing contractor approved by the manufacturer, where a proprietary system is used
- installed by the same contractor who installs the AVCL, insulation and surface finish
- checked by the contractor to ensure that the deck and insulation boards are waterproofed at the end of each day with 'night joints' and before inclement weather
- installed so that membrane laps near outlets do not impede drainage ie, outlets should be recessed to avoid forming a raised lip with the waterproofing layer
- installed so that successive layers do not trap water.

Inverted roofs should:

- not be used for slopes greater than 10 degrees
- be laid on a deck with no back falls or ponding
- be designed to support the loads, particularly from ballast needed to retain insulation
- be ballasted to the depth specified in the design to resist wind uplift, flotation and provide fire protection, using minimum 40mm paving slabs or 20-40mm diameter rounded shingle ballast minimum 50mm deep, subject to any other requirements to meet fire protection measures
- installed with a separating layer between the waterproofing layer and inverted warm roof insulation where required by the membrane manufacturer.

Note

The depth of ballast required to resist flotation may exceed the minimum depths needed to meet the fire protection.

7.1.11.2 Waterproofing systems

Table 10: Waterproofing layer materials

Material	Standard	Code of practice	Other guidance
Reinforced bitumen membrane (RBM)	BS 8747 BS EN 13707	BS 8217 BS 6229	
APP and SBS modified bitumen roofing systems	BS EN 13707 evaluation of conformity	BS 8217 BS 6229	Standards as listed in BS EN 13707 Normative references
Mastic asphalt	BS 6925	BS 8218	Mastic Asphalt Roofing TECHNICAL GUIDE Mastic Asphalt Council (MAC)
Plastic and rubber sheets	BS EN 13956		SPRA S01-2020 SINGLE PLY ROOFING DESIGN GUIDE 2020 Single Ply Roofing Association
Liquid applied waterproofing (hot or cold applied)			LRWA DESIGN GUIDE issue 1 Liquid Applied Waterproofing Systems for Roofs and Balconies 2020 ETAG 005 Liquid applied roof waterproofing kits Part 1: General GUIDELINE FOR EUROPEAN TECHNICAL APPROVAL Rev. March 2004

Reinforced bitumen membranes (RBM) and modified bitumen roofing systems

Bitumen membranes should be high performance to BS EN 13707 Flexible sheets for waterproofing. Reinforced bitumen sheets for roof waterproofing. Definitions and characteristics and reinforced with polyester reinforcement. SBS (elastomeric) modified bitumen membranes offer increased extensibility and flexibility, especially at low temperatures. APP (plastomeric) modified bitumen membrane products offer resistance to UV degradation, have high softening points and provide a longer service life than traditional RBMs.

Built-up bitumen membrane roofs should be complete systems provided by the membrane manufacturer and installed in accordance with BS 8217 Reinforced bitumen membranes for roofing. Code of practice and the membrane manufacturer's instructions.

The installation methods should consider the safe use and application of any hot applied materials including such guidance as the NFRC's Safe2Torch guidance.

Table 11: Modified bitumen membranes used in warm roof construction

Deck	Preparation	AVCL RBM minimum (S2P3) or modified bitumen membranes	Insulation	First/preparatory layer (S2P3)	Final layer/cap sheet ⁽²⁾ with integral surface protection ⁽³⁾
Concrete or screed	Smooth surface, and prime	Applied in accordance with the membrane manufacturer's instructions	See note under Table 12	Applied in accordance with the membrane manufacturer's instructions	Applied in accordance with the membrane manufacturer's instructions
Plywood or OSB	Prime deck				
Profiled metal eg steel, aluminium	Stitch side laps, prime crowns (or timber decking where provided)				

Table 12: Modified bitumen membranes used in an inverted warm roof construction

Deck	Preparation	First/preparatory layer (S2P3)	Final layer/cap sheet ⁽²⁾
Concrete or screed	Smooth surface and prime	Applied in accordance with the membrane manufacturer's instructions	Applied in accordance with the membrane manufacturer's instructions

Notes to Tables 11 and 12

- Insulation to be mechanical or adhesive fixed to deck in accordance with the design of the roof build-up. Torching on to insulation boards and timber deck is not acceptable, apart from suitable insulation boards, eg rock fibre, perlite or foam insulation boards with a torch receivable facing.
- Classification by performance should be in accordance with BS 8747, eg a minimum value of S2P3 for ballasted roofs with access for light maintenance only and minimum S5P4 for accessible roofs with paving slabs on supports. S = tensile strength and elongation, P = resistance to puncture ie, both static and dynamic. The higher the number, the better the performance.
- The use of stone chippings is not recommended unless required to enhance fire protection. Solar reflective paint, if used, should not be used as the sole protective finish to the membrane.

Mastic asphalt

Mastic asphalt should be:

- to BS 6925, type 988 T25, 20mm thick on the flat and installed on black sheathing felt
- 3 x 10mm layers on horizontal surfaces and 3 layers with a total thickness of 20mm on vertical surfaces, for upstands to walls on Green Roofs.

Polymer modified asphalt should be assessed in accordance with Technical Requirement R3.

Single-ply membrane

Single-ply membranes, including materials such as PVC, EPDM, and TPO (thermoplastic polyolefin) should be:

- either bonded to the insulation, mechanically fixed to the deck or loose laid, and sealed and ballasted (fixing methods should be in accordance with the manufacturer's recommendations)
- welded at laps using either hot air or a specific solvent with or without taped seams
- designed and installed in accordance with SPRA Design Guide
- assessed in accordance with Technical Requirement R3.

Liquid applied membranes

Liquid applied membranes, including hot and cold applied systems, should be:

- selected and applied in accordance with the LRWA DESIGN GUIDE issue 1 Liquid Applied Waterproofing Systems for Roofs and Balconies 2020
- applied in accordance with the manufacturer's recommendations
- assessed in accordance with Technical Requirement R3.

Fully supported flat sheet hard metal roof

Fully supported flat sheet hard metal roof coverings should be designed and constructed:

- to the material Standards as shown in Table 13 and assessed in accordance with Technical Requirement R3
- in accordance with BS EN 14783 Fully supported metal sheet and strip roofing, external cladding and internal lining. Product specification and requirements
- in accordance with the relevant codes of practice and technical guidance documents published by the Metal Cladding & Roofing Manufacturers Association (MCRMA)
- to avoid damage from condensation
- to follow the supply manufacturer's recommendations (including design for thermal movement and wind uplift)
- for roofs with maintenance access only.

Table 13: Fully supported flat sheet hard metal roof coverings

Metal type	British Standard
Aluminium (Al)	BS EN 485-1
Copper (Cu)	BS EN 1172
Galvanised steel (Gst)	BS EN 10346
Stainless steel (Sst)	BS EN ISO 9445 Parts 1 and 2
Titanium zinc (Zn)	BS EN 988

Direct contact between dissimilar metal roof coverings and metal fixings can cause corrosion; similarly, rainwater from dissimilar metal roofs should not discharge on to one another. Acid run-off from timber cladding, contact with fresh cement mortar, and acidic cleaners can also affect metal roofing, particularly Zinc, and in marine environments, metal roofing can suffer unsightly salt deposits. Various coatings have been developed to protect against corrosive environments and unsightly deposits. Advice on the above aspects should be sought from the metal roofing manufacturer when considering the roof design.

It is essential that interstitial condensation does not build up on the underside surface of metal roof coverings. This trapped moisture will increase the risk of corrosion developing in key parts of the construction containing metals such as Zinc, Aluminium and galvanised steel. Prevention of interstitial condensation should be achieved by a ventilated design for either of the cold or warm roof types — with each having a ventilated void beneath the deck supporting the metal covering.

Ventilation needs to be effective in accordance with BS 5250 and BS 6229, with minimum 50mm ventilated void with continuous 25mm edge ventilation gaps and a maximum 5m between ventilation points in the direction of the joists. With verge to verge cross-ventilation, and ventilation in the direction of the joists and 5-10m between ventilation points, a ventilation gap of minimum 100mm and continuous edge ventilation gaps of 60mm is recommended. Intermediate mushroom ventilators are ineffective in reducing these ventilation distances.

Note

Ventilation gaps should have mesh or grilles (nominal 4mm openings) to stop the entry of large insects and birds.

Ventilation also helps form a protective patina to the underside of aluminium, galvanised steel and zinc. Timber sarking boards with 3-5mm gaps between are the preferred deck option; if plywood is used, it should have 3-5mm gaps between boards. The metal should be laid on a structural underlay ie, a breathable underlay with outer layer of bonded polypropylene mesh, which assists air and moisture movement, all in accordance with the metal roof manufacturer recommendations.

Figure 24: Ventilated cold roof design

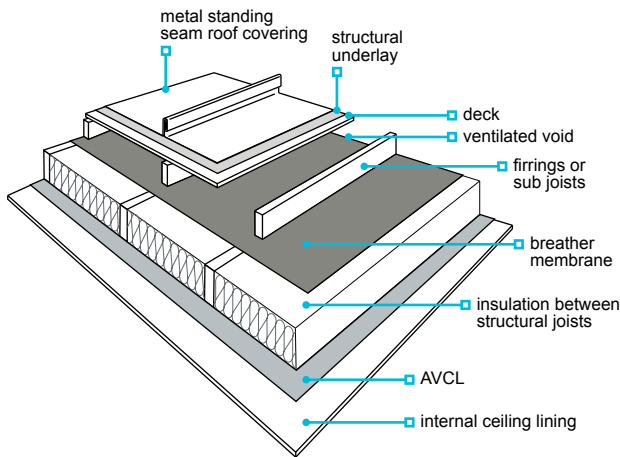
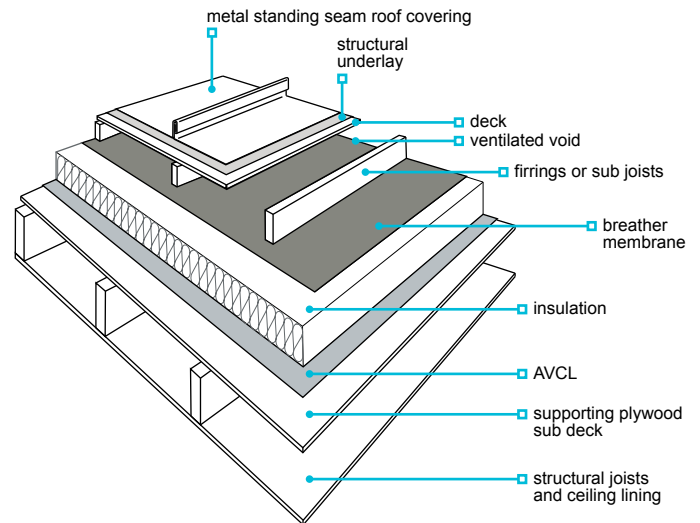

Figure 25: Ventilated warm roof design



Fully supported lead roof

Fully supported lead roofing should be:

- laid loose on building paper to BS 1521 Class A for plywood deck or smooth concrete/screed deck, or polyester geotextile felt for timber boards (fitted with penny width air gaps)
- installed as a ventilated cold or ventilated warm roof system
- installed in accordance with BS 6915, The ultimate guide to best practice as published by the Lead Contractors Association or other manufacturers recommendations
- installed to include allowance for thermal movement and uplift
- treated with patination oil directly after installation where rainwater run-off may cause staining to adjoining surfaces.

Table 14: Lead materials for roofing

Metal type	British Standard	Code of practice
Lead (rolled)	BS EN 12588	BS 6915
Lead (machine cast)	BS EN 14783	

Integrity testing of waterproofing layer

The waterproofing layer should be inspected for defects after installation. Any defects are to be repaired and retested and left in a satisfactory condition.

Waterproofing layers on flat roofs, terraces and balconies greater than 50m², or roofs which are difficult to access (such as on buildings over three storeys), should be subject to visual inspection and an appropriate integrity test, undertaken by a suitably qualified surveyor.

Waterproofing layers under 50m² or those unsuitable for electronic testing, eg EPDM or foil-faced bitumen membranes, may be checked by visual inspection which should include inspection of any seams with suitable probes.

Guidance on electronic test methods and their application can be found on the Roofing And Waterproofing Test Association website.

A test report containing the test results and photographic record of the roof should be made available to NHBC.

7.1.11.3 Surface treatments

Surface treatments should be in accordance with Table 15.

Table 15: Surface treatments for flat roofs

Material	Access for maintenance only	Access roof, walkway or terrace
Reinforced bitumen membranes	<ul style="list-style-type: none"> mineral surfaced cap sheets (eg type S5P5) reflective stone chippings⁽¹⁾, bedded in a bitumen-based compound a minimum thickness of 50mm washed, rounded 20-40mm shingle ballast laid loose 	<ul style="list-style-type: none"> precast semi-porous concrete tiles bedded in bitumen or approved adhesive precast concrete proprietary paving slabs on supports, or sand/cement blinding⁽²⁾ proprietary decking systems⁽³⁾
Single-ply membranes	<ul style="list-style-type: none"> supplementary solar reflective coatings or other finishes not required where laid loose, membranes can be ballasted with a 50mm minimum thickness of washed, rounded 20-40mm shingle ballast installed on a non-woven polymeric protection layer 	<ul style="list-style-type: none"> proprietary flexible, non-slip walkway sheets or tiles, compatible with the membrane product precast concrete proprietary paving slabs on adjustable supports or suitable non-woven polymeric protection layer proprietary decking systems⁽³⁾ with bearers set on an additional membrane or suitable non-woven polymeric protection layer⁽³⁾
Cold applied liquid roofing membranes	<ul style="list-style-type: none"> products generally do not require supplementary solar reflective coatings or other finishes 	<ul style="list-style-type: none"> proprietary surface treatments compatible with the membrane product proprietary non-slip walkway tiles compatible with the membrane product precast concrete proprietary paving slabs on supports on a suitable non-woven polymeric protection layer proprietary decking systems⁽³⁾ with bearers set on additional pads on suitable non-woven polymeric protection layer/filter layer⁽³⁾
Hot melt rubberised bitumen systems	<ul style="list-style-type: none"> use in inverted/buried membrane applications or in roof garden/Green Roofs must be protected with a substantial reinforced bitumen membrane protection sheet or protection board all upstands/details where the membrane becomes exposed need a protective membrane to be applied to prevent UV degradation 	
Mastic asphalt	<ul style="list-style-type: none"> reflective stone chippings⁽¹⁾, bedded in a bitumen-based compound solar reflective paint in accordance with BS 8218 	<ul style="list-style-type: none"> precast semi-porous concrete tiles bedded in bitumen or approved adhesive precast concrete proprietary paving slabs on supports or sand/cement blinding⁽²⁾

Notes

- Loose surface finishes should be prevented from being removed by weather and discharged into gutters and drainpipes. Chippings should be a minimum of 12.5mm limestone or white spar, not pea gravel.
- Cement/sand blinding should be installed on two layers of 1000 gauge polyethylene separating membrane.
- Decking systems must meet the fire protection requirements for the overall roof construction and should be securely fastened to a loadbearing support structure.

7.1.11.4 Fire protection

The surface protection provided to the waterproofing layer must satisfy the fire protection requirements as set out in the Building Regulations.

Account must be taken of the waterproofing detail at abutments with a building and the extent that the waterproofing can be dressed up the wall of the building, and the jointing detail between the roof waterproofing and the cavity trays/DPC. This may include the use of non-combustible trays in the external wall of the building.

Extensive Green Roof systems should include non-combustible perimeter abutment strips to buildings, roof lights, etc and at regular intervals across the roof. Sustainable roof types, including Green Roofs and Brown Roofs, should be designed for resistance to fire spread in accordance with guidance in The Green Roof Organisation — GRO fire risk guidance document and in full compliance with Building Regulations.

7.1.12 Green and biodiverse roofs – including roof gardens

Green and biodiverse roofs shall be suitable for their intended use.

Green and biodiverse roofs should:

- be designed with a finished fall at the waterproofing layer of 1:60 (1°) minimum
- be designed in accordance with the GRO Green Roof Code of Best Practice 2021 and CIRIA C753 SuDS Manual 2015
- have a certified waterproofing system that is endorsed by the manufacturer as fully suitable to be specified for a green sustainable roof design
- be designed to take account of wind uplift and flotation
- have supporting data to demonstrate compliance with relevant material standards and codes of practice
- include a waterproofing layer suitable for use in the specified roof system
- have rainwater outlets that are accessible and have a visible inspection hatch.

Green and biodiverse roof systems that do not comply with the principles of this chapter should be assessed in accordance with Technical Requirement R3.

Both the green/biodiverse roof system and the waterproofing layer should be installed by a contractor trained and approved by the system supplier.

The waterproofing layer should be either:

- reinforced bitumen membrane
- mastic asphalt
- single-ply membrane, or
- a liquid applied system (cold or hot melt).

The system should be installed in accordance with the design and the waterproofing layer manufacturer's recommendations and integrity tested prior to covering (see Clause 7.1.11, integrity testing of the waterproofing layer).

Other issues that should be considered when installing Green Roofs include the:

- provision of a root barrier or use of a waterproofing layer that is resistant to root penetration in accordance with BS EN 13948
- height of upstands in relation to soil height and flashings
- protection, reservoir and filter layers
- moisture control of the soil.

Figure 26: Intensive Green Roof on warm roof deck

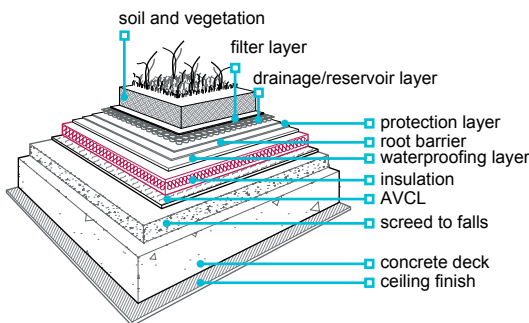

Figure 27: Extensive Green Roof on warm roof deck

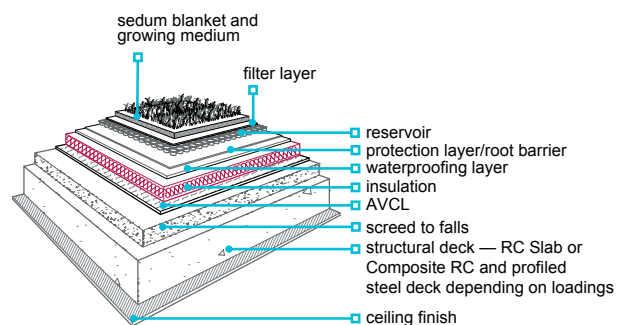

Figure 28: Intensive Green Roof on inverted warm roof deck

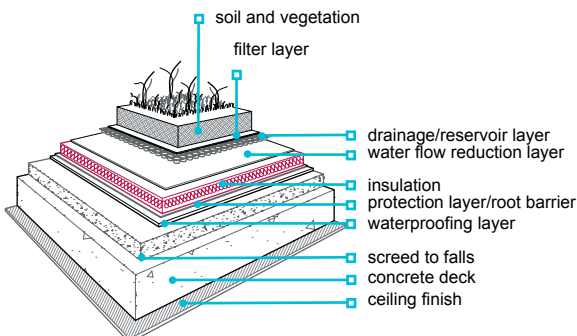

Figure 29: Extensive Green Roof on inverted warm roof deck

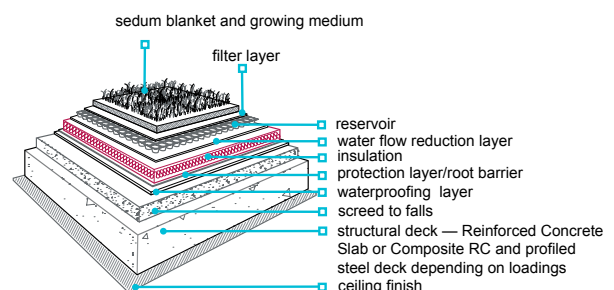

Table 16: Principles for Green Roofs

	Intensive	Extensive
Features	<ul style="list-style-type: none"> provides a normal garden environment uses natural topsoil at least 150mm deep and 'normal' plants such as grass, bushes, shrubs and trees requires regular 'intensive' maintenance ie, like a normal garden requires protection of the waterproofing membrane from possible damage during maintenance of the garden, eg from weeding/planting 	<ul style="list-style-type: none"> requires minimal maintenance, ie, annual attention types of planting includes sedum in a blanket or modular trays, wildflower blanket, non-blanket solutions using plug plants or hydroseeding
Structure	<ul style="list-style-type: none"> 10° maximum roof pitch unless anti-shear measures are taken, accounting for full weight of wet soil (generally supported by a concrete deck) 	<ul style="list-style-type: none"> 45° maximum roof pitch deck (profiled metal deck or concrete deck depending on load)
Drainage falls	<ul style="list-style-type: none"> finished fall of 1:60 at drainage level 	
Moisture control	<ul style="list-style-type: none"> irrigation system may be required can be designed to retain some water in order to maintain the vegetation and to reduce run-off 	
AVCL	<ul style="list-style-type: none"> fully bonded polyester — reinforced RBM (S2P3), a suitable self-adhesive membrane or a torch-on membrane 	
Insulation	<ul style="list-style-type: none"> insulation material should have adequate compressive strength to withstand likely applied loads 	
Roots	<ul style="list-style-type: none"> a root-resistant element is required above the waterproofing layer; alternatively, an approved root-resistant waterproofing layer can be used (consideration should be given to the potential for large roots to enter and disrupt inverted warm roof insulation; the system provider should be consulted for advice) 	
Protection and filter layers	<ul style="list-style-type: none"> a protection layer (or board) should be placed above the waterproofing layer a filter layer should be placed above the reservoir layer 	<ul style="list-style-type: none"> in accordance with the manufacturer's recommendations

7.1.13 Blue Roofs

Blue Roofs shall be suitable for their intended use.

Blue Roofs should:

- be designed in accordance with relevant parts of BS 6229 and the NFRC Technical Guidance Note for the construction and design of Blue Roofs. Roofs and podiums with controlled temporary water attenuation
- have a certified waterproofing system that is endorsed by the manufacturer as fully suitable to be specified for a Blue sustainable roof design
- have supporting data to demonstrate compliance with relevant material standards and codes of practice
- include waterproofing layer suitable for use in the Blue Roof system and subject to independent third-party assessment
- have specific flow restrictor outlets to meet the required water discharge rate and which are accessible for inspection and maintenance
- fully drain over the designed retention period (permanent retention of water is not accepted on the roof waterproofing layer)
- include overflows independent of the rainwater drainage system, to avoid water ingress into the building should the water attenuation level be exceeded (operation of an overflow should be visible to warn of a potential blockage in the drainage system)
- have minimal penetrations of the waterproofing layer other than rainwater outlets and overflows
- be designed as a warm roof or inverted warm roof.

If designed as an inverted warm roof, the design should take into account the additional thickness of insulation, over and above the dry state 'U' value calculation, that is required to compensate for the cooling effect of water penetrating the insulation and reaching the waterproofing layer, in accordance with the guidance in BS 6229.

The design should also include sufficient topping of ballast, paving or Green Roof to avoid flotation of the insulation, flotation forces can be quite significant and occur before the attenuation system reaches full capacity.

Care should also be taken in the design and installation of the WFRL so that it performs as the principal drainage layer and reduces water penetration to the insulation layer below.

The WFRL should be:

- lapped and sealed to avoid/minimise rainwater getting below the insulation layer
- lapped and taped onto the lip of the water attenuation chamber
- finished a minimum of 50mm above the top of the Blue Roof attenuation level at parapets/upstands
- taken up all protrusions/penetrations and sealed (this includes between the top of the insulation layer and the bottom of the recessed lip of the water attenuation chamber, and behind parapet chambers).

7.1.14 Raised and buried podiums

Podiums shall be protected by adequate weatherproofing and drainage.

Podium roofs

Podiums shall be protected by a fully co-ordinated waterproofing and drainage system as part of the design. Products used for waterproofing and damp proof courses should have accredited third-party certification, with proof of performance from relevant testing. For particular specified conditions of use in construction, wherever applicable, this testing should include membrane resistance to root penetration and durability performance for waterproofing of concrete surfaces trafficable by vehicles. Also, where relevant for compliance, refer to Chapter 5.4 Waterproofing of basements and other below ground structures, BS EN 13967:2012 and Property Care Association guidance document — Podium Decks and Buried Roofs.

A raised podium is a deck or terrace, usually situated over a non-habitable space where thermal insulation is generally not required.

Waterproofing system combinations should be designed and installed to fully protect the envelope and provide continuity of a water-resistant barrier, along all interfaces between the raised podium ie, bridging across to the superstructure and/or the basement substructure. Chapter 5.4 Waterproofing of basements and other below ground structures provides further details of the design and construction of podium at or below ground level (buried podiums).

The make-up of the waterproofing layer and topping should follow the guidance given for the individual waterproofing layers and toppings quoted within this chapter and to suit the type of deck that has been used to form the podium.

Consideration must be given to emergency vehicular traffic at the planning stage and, where necessary, waterproofing and structural designs must be capable of accommodating foreseeable loading. Also see Chapter 5.4 with reference to the figures below.

Figure 30: Raised podium

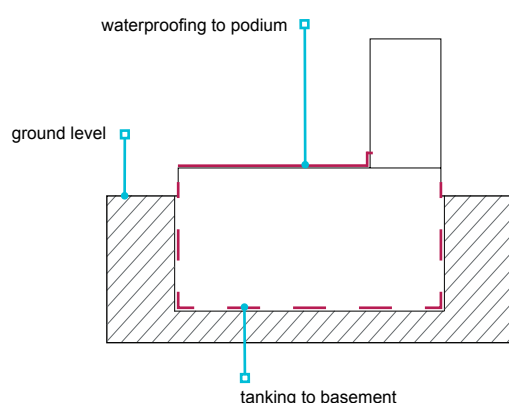
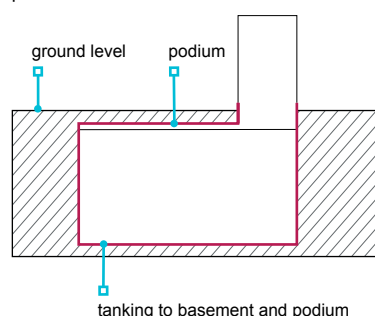

Figure 31: Buried podium



7.1.15 Detailing of flat roofs

Flat roofs shall be detailed to ensure satisfactory performance.

Table 17: Materials for flashings

Flashing material	Guidance
Rolled lead sheet	Minimum Code 4. BS EN 12588
Aluminium and aluminium alloys	BS EN 485 and BS EN 573, 0.6-0.9mm thick and protected from contact with mortar by a coating of bituminous paint
Zinc alloys	BS EN 988 and 0.7mm thick
Copper	BS EN 1172, 0.6mm thick and fully annealed
Stainless steel	BS EN ISO 9445 Parts 1 and 2
Galvanised steel	BS EN 10142/3
Proprietary flashing, including plastic and composite	Assessed in accordance with Technical Requirement R3

Note
Where two metals are to be joined, they should be compatible and not cause bimetallic corrosion in that environment. Alternatively, they should be isolated from each other.

The following figures are intended as a guide to demonstrate the general principles of the flat roof, detailing commonly used on flat roofs, terraces and balconies. Where indicated, the principles are applicable to other types of roof construction. Further information on specific waterproofing systems may be obtained from BS 6229 and BS 8217.

Concrete decks

Upstands may be fixed to the wall and should be a minimum of 150mm high. Similar details apply to inverted roofs with concrete decks.

Figure 32: Upstands

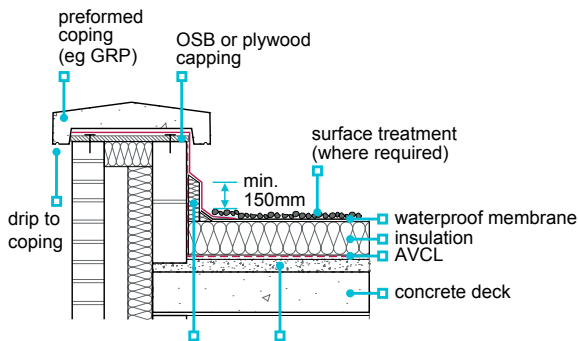

Similar details apply to inverted roofs. Allow for thickness of ballast to achieve a minimum 150mm upstand.

Figure 33: Skirting to rooflights or ventilator kerb

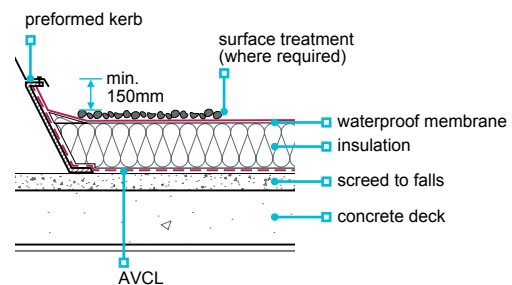

Similar details apply to inverted roofs.

Figure 34: Twin-kerb expansion joint

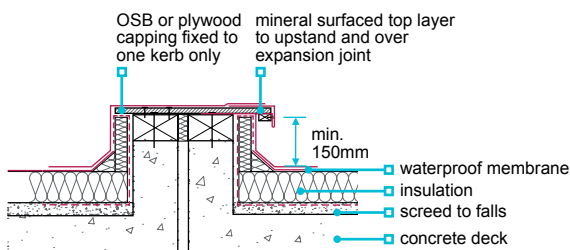

Timber decks

Elements should be firmly fixed to prevent peelback in high winds.

Figure 35: Mansard edge

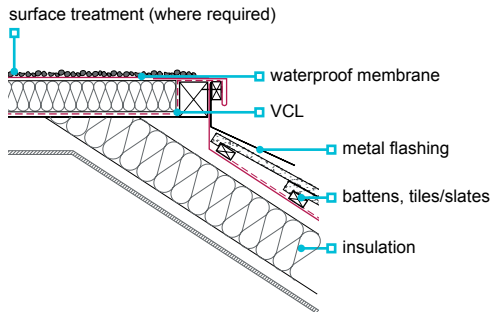

The upstand should be a minimum of 150mm high above surface finish. Upstands should be kept separate from wall, and allow for movement. Similar details apply to cold deck timber roofs.

Figure 37: Independent skirting detail

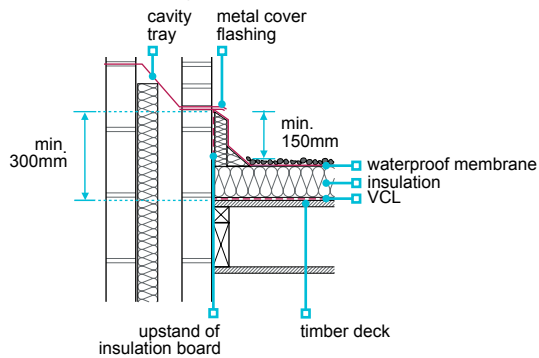

Inverted timber decks should be detailed to avoid insulation being lifted by wind suction, and an alternative detail used.

Figure 39: Weltd drip to external gutter

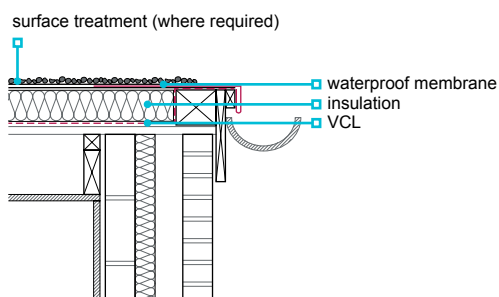
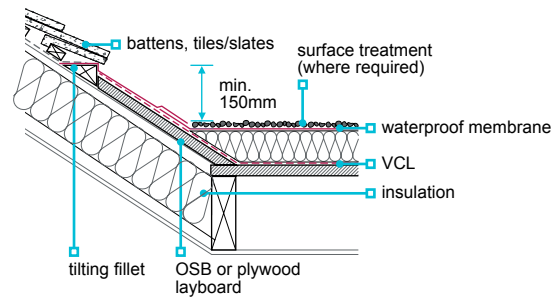
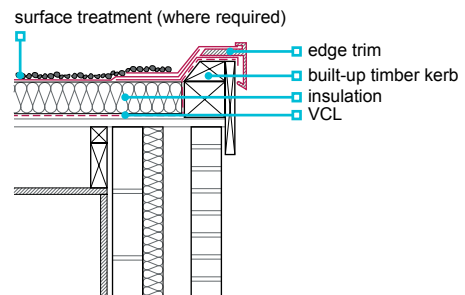

Figure 36: Pitched roof abutment



Similar details apply to inverted decks.

Figure 38: Verge detail



A VCL should be bonded to the waterproofing. Detailing of upstand and flashing is similar for all roofs.

Figure 40: Pipe passing through roof

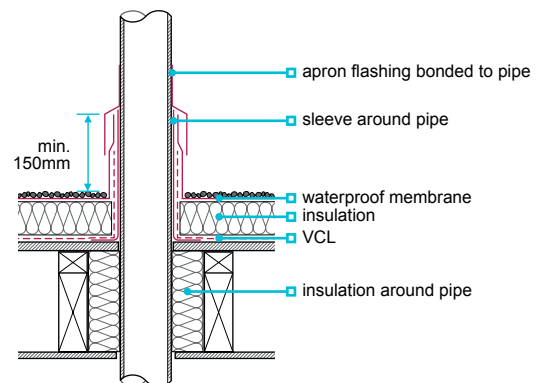

Similar details apply to cold and inverted roofs. Allow for the thickness of ballast in inverted roofs, to achieve upstand dimensions.

Figure 41: Upstand to ventilator or rooflight kerb

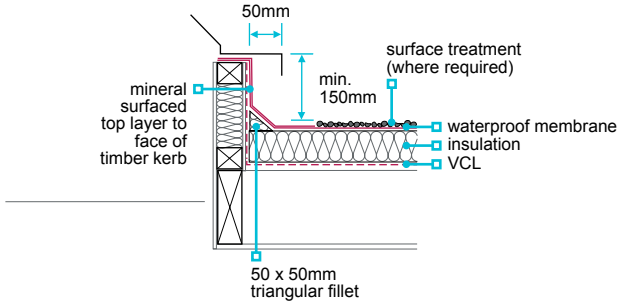

Outlet should be at the lowest point in the roof. The opening should be properly trimmed. Ensure that the outlet is fixed securely to decking to prevent displacement by thermal expansion of the rainwater pipe. Similar details apply to concrete roofs.

Figure 42: Rainwater outlet

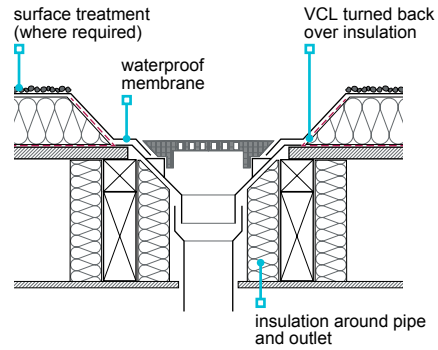
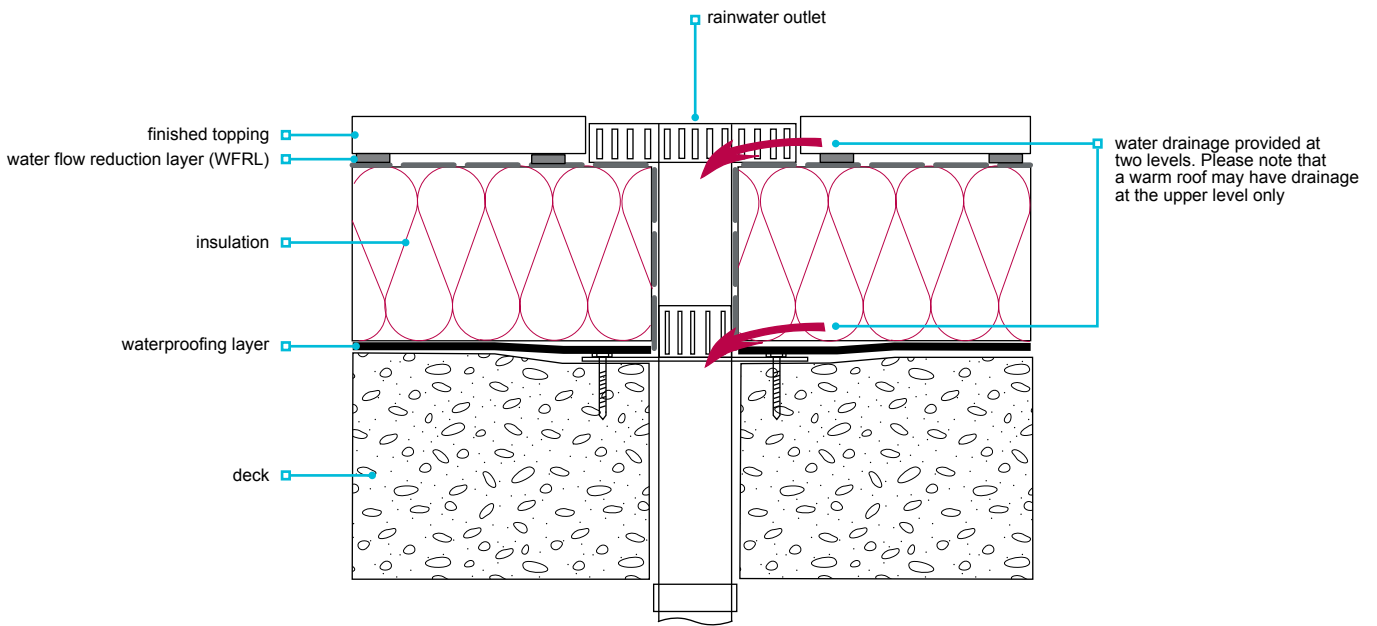

Figure 43: Inverted warm roof drainage outlet



7.1.16 Accessible thresholds and upstands

Accessible thresholds shall be protected by adequate weatherproofing and drainage.

Generally, where a flat roof or terrace abuts a wall, the waterproofing layer should extend up the wall to form a minimum 150mm upstand measured from the balcony/terrace drainage layer of the roof/terrace. The waterproofing material forming an upstand should link directly under a cavity tray to ensure the cavity fully drains outwards. Weepholes should be provided in masonry walls at 1m maximum spacings to assist drainage.

Where any door threshold or window sill is located less than 150mm above the balcony/terrace drainage layer the upstand and accessible threshold design requirements, as shown in the figures below, should apply. This should include doors with level access and fenestration designs involving windows adjacent to the internal floor level and the external paving/decking level.

Designs which continue the waterproofing layer horizontally through/under the outer leaf of a cavity wall and form an upstand against the inner leaf within the cavity are not acceptable because:

- materials used for the waterproofing layer are generally unsuitable to perform as a DPC supporting masonry loads
- the cavity must fully drain to avoid water retention problems arising from prolonged saturation of the wall material with risks from frost action damage and stagnant retained water
- water draining from the waterproofing layer must not be directed into a cavity wall
- future inspection, repair and maintenance of hidden upstands cannot be carried out without significant disruption to the construction.

Accessible thresholds should:

- be in accordance with the design — specific fire, thermal, waterproofing and acoustic precautions may be required
- have a maximum 15mm upstand at the threshold (measured at the door position); additional sloping transition elements, such as a small internal ramp and external sill, may be provided either side of the upstand; the maximum slope on the ramps and sills should be 15 degrees
- have a minimum 45mm projecting sill to shed rainwater away from the interface with the waterproofing layer, with a drip feature a minimum 30mm away from the face of the upstand
- have a 75mm minimum balcony upstand below the underside of the projecting sill, measured from the balcony/terrace drainage layer.

Figure 44: Uninsulated balcony deck

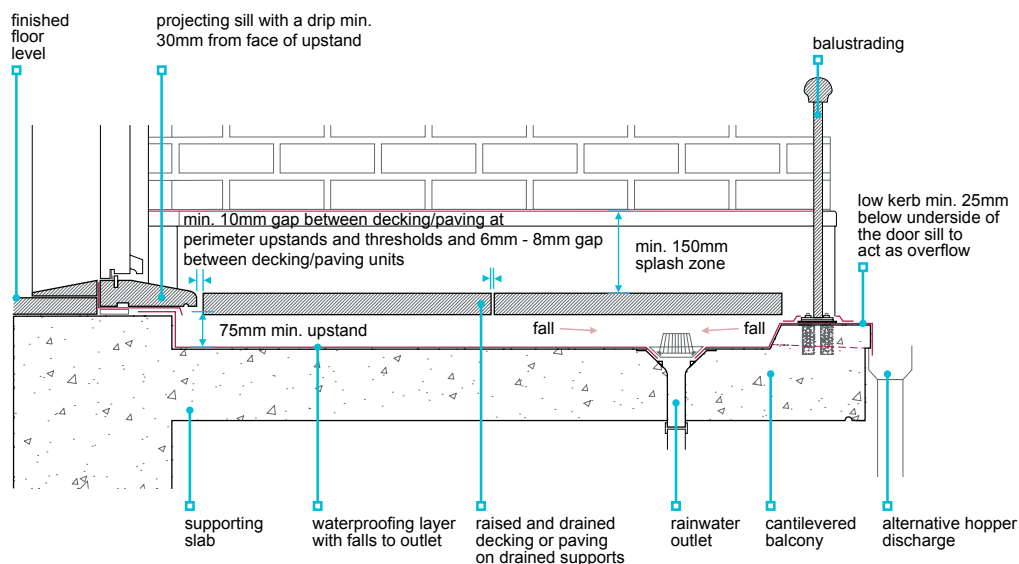

Figure 45: Insulated terrace deck

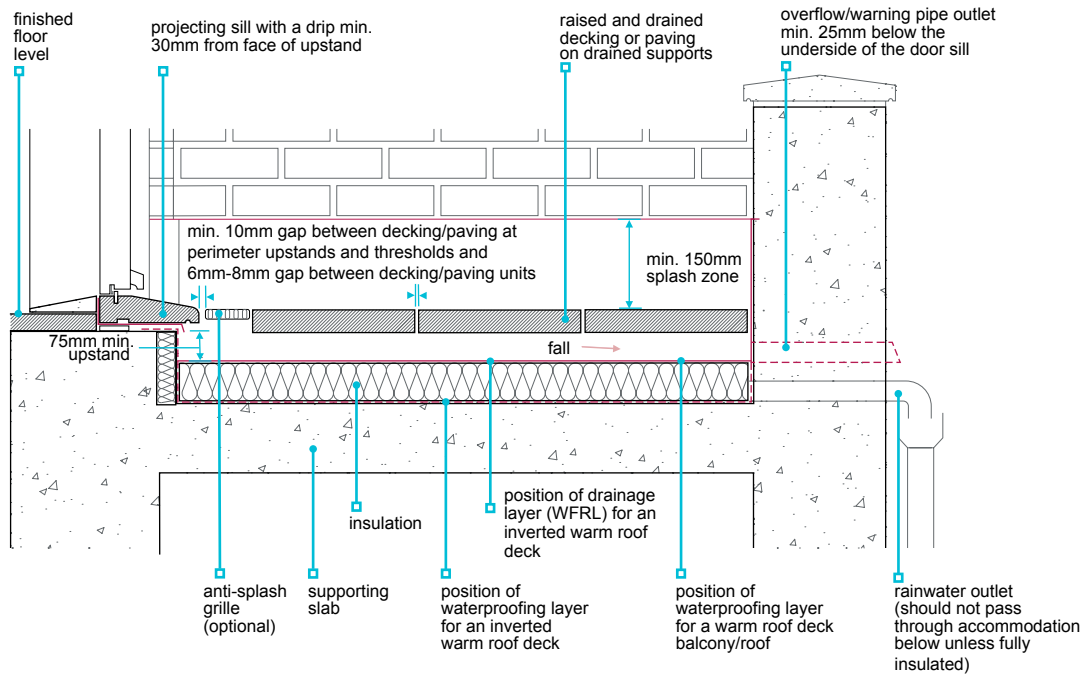
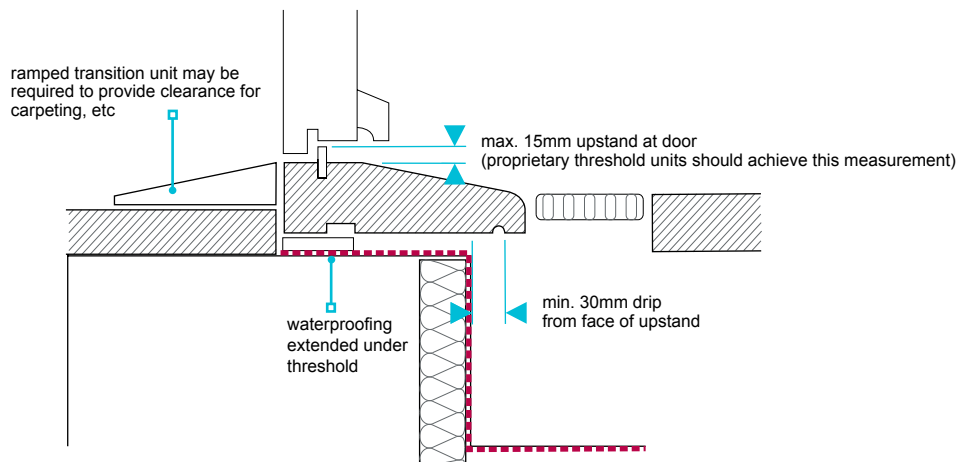

Figure 46: Accessible threshold



Waterproofing layers should:

- be laid without forming ponding and associated stagnant water
- have a finished fall of a minimum of 1:80 to rainwater outlet(s)
- be subject to specific third-party assessment where falls are zero degrees with no back falls or ponding
- be designed to ensure that where falls are towards or parallel to the building, blockage of the outlet(s) cannot cause flooding to the building
- be fully protected from direct trafficking
- be capable of withstanding point loads from supports to decking or paving
- be UV resistant or fully protected from daylight.

Drainage arrangements should be effective and have a suitable overflow. The building should not flood where an outlet or downpipe is blocked. This can be achieved by using:

- at least one outlet and an overflow with at least the capacity of the outlet
- at least one outlet chute and hopper (chute should be sized to serve at least twice the discharge capacities to allow for partial blockage without causing flooding into the building)
- two outlets connected to independent downpipes such that if one downpipe becomes blocked, the other outlet(s) can still cope with the discharge, or
- setting the balcony kerb a minimum 25mm below the door threshold to discharge safely without causing any adverse effect to the construction below.

Outlets beneath decking or paving should be clearly identified and accessible for maintenance.

To ensure adequate drainage:

- As-built gaps of 10mm-12mm should be provided between decking/paving units along perimeter upstands/thresholds
- As-built gaps of 6mm-8mm should be provided between individual units of decking or paving
- spacers and supports which raise the decking or paving should not obstruct the flow of rainwater to outlet(s).

A splash barrier around the perimeters should be provided:

- to ensure water does not reach any part of the wall that could be adversely affected by the presence of moisture
- to a minimum of 150mm above the decking or paving
- using an impervious wall finish or cladding or by extending the waterproofing layer to form an upstand with cover flashing and cavity tray (impervious masonry units with porous bed joints are unsuitable within this zone).

7.1.17 Metal balcony decking systems

Metal balcony framework structures and metal balcony decking systems should be designed and constructed as recommended in BS 8579 guidance for the design of balconies and terraces and their component parts.

7.1.18 Parapets and guarding to terraces and balconies

Terraces and balconies to which persons have regular access, other than for maintenance, shall be adequately guarded to minimise the risk of falling. Issues to be considered include:

- 1) guarding
- 2) stability of guarding
- 3) strength, movement and weatherproofing of masonry balcony walls
- 4) durability and fixing of balustrading and guard rails
- 5) access for maintenance.

7.1.18.1 Guarding

Guarding should:

- not be easily climbed by young children
- be to an adequate height
- be toughened glass, laminated glass (subject to meeting fire regulations) or glass blocks (suitably reinforced) where glazed balustrading is used
- not inhibit the flow of drainage on the waterproofing layers or overflows in the event of a blocked outlet.

7.1.18.2 Stability of guarding

Guarding, including parapet walls and balustrading used as guarding, should be designed in accordance with BS EN 1991-1-1 to resist horizontal loading and as required by Building Regulations. Care is needed when the design incorporates balustrading fixed to parapet walls to ensure stability and prevent overturning. End fixings into walls or returns may be needed to ensure stability.

The structural stability should be checked for balcony walls, especially long balconies. Cavity walls and DPCs in the wall can create a slip plane that can seriously limit the ability of the wall to resist horizontal forces. In such cases, it may be necessary to incorporate a ring beam or other support to ensure stability.

7.1.18.3 Strength, movement and weatherproofing of masonry balcony walls

Masonry balcony walls should be built in accordance with Chapter 6.1 External masonry walls. In particular:

- walls should incorporate strengthening as required by the design
- movement joints should be provided in accordance with the design
- tops of walls should be weatherproofed with a coping, or by the deck waterproofing layer taken up and over the masonry wall
- copings should be firmly fixed
- copings should project a minimum 45mm beyond the faces of the wall below and incorporate a drip feature that discharges water at least 30mm away from the face of the wall and stops water running back under the coping
- preformed edge trims that are sealed to and form a finished edge to the waterproofing layer and which extend down over the wall/fascia, may have a lesser drip projection provided the waterproofing layer drains away from the trim
- copings should incorporate DPCs and cavity trays linked to the waterproofing layer upstands
- cavity trays should be installed to discharge towards the external face of the wall and incorporate weepholes at maximum 1000mm centres.

Figure 47: Parapet wall waterproofing details at roof upstand and head coping

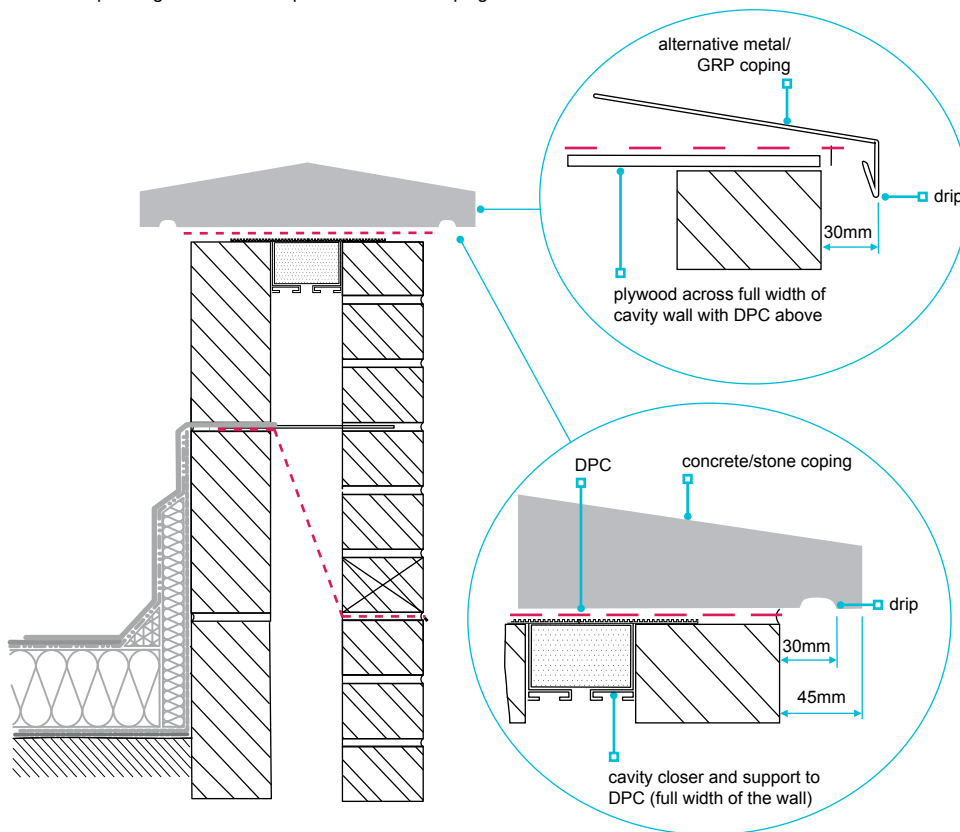
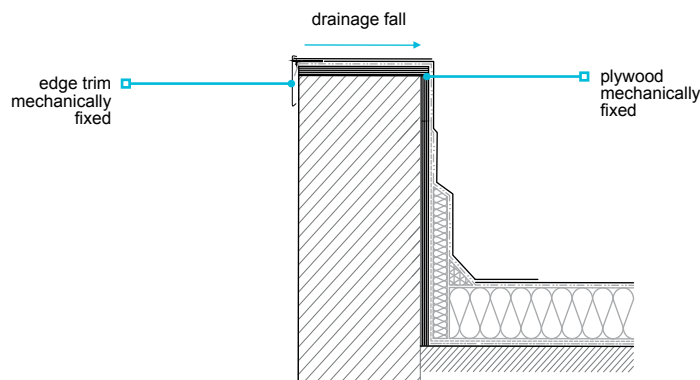

Figure 48: Parapet detail with waterproofing taken over top of wall and finished with edge trim



7.1.18.4 Durability and fixing of balustrading and guard rails

Balustrading and guard rails should be of adequate durability and fixed securely. The structure to which the balustrading and guard rails are fixed should be adequate to safely resist the potential forces acting on the guarding.

Balustrading should not be:

- fixed through a coping or capping due to the difficulties in achieving a waterproof junction with the coping or capping and maintaining an impermeate DPC beneath the coping or capping
- fixed through the waterproofing layer unless suitable precautions are taken to provide a waterproof junction, eg locating baseplates on a raised waterproofed kerb or surrounding the baseplates in a pitch pocket detail.

These issues should be avoided by fixing the balustrading to the face of the wall below the coping or capping.

Figure 49: Pitch pocket sealing detail around post fixed to deck

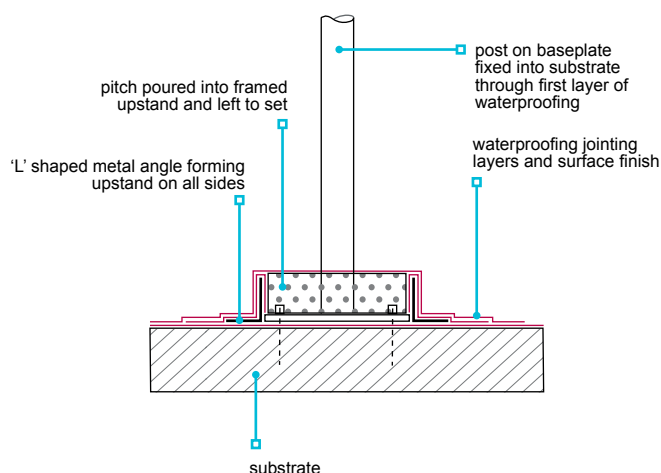

Figure 50: Handrail fixing on upstand formed in concrete roofs

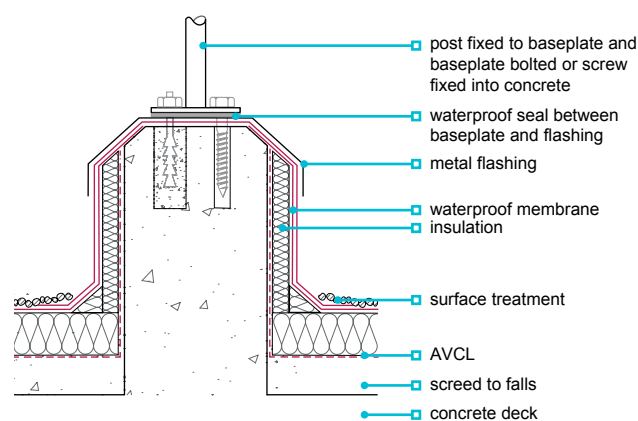

Figure 51: Base of balustrade post raised above drainage level

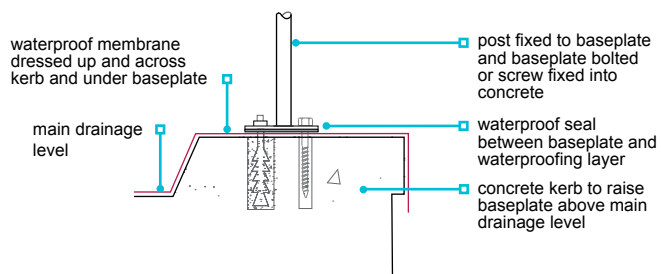
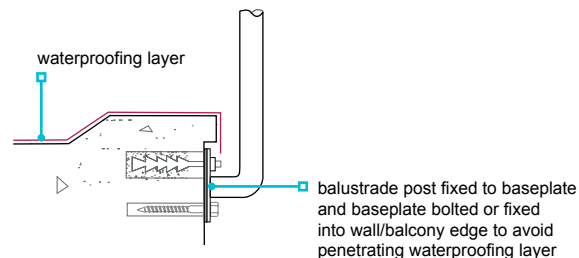

Figure 52: Balustrade post fixed to wall below coping/kerb



Particular attention should be given to use of materials or finishes that resist corrosion or unsightly surface staining in aggressive environments such as coastal zones.

Note

Ferritic stainless steel can suffer surface rusting/staining in coastal zones.

7.1.18.5 Access for maintenance

Provision should be made for safe future access to flat roofs for the purposes of maintenance.

7.1.19 Further information

- *BS EN 13162 Thermal insulation products for buildings — Factory made Mineral Wool (MW) products. Specification*
- *BS EN 13163 Thermal insulation products for buildings — Factory made expanded polystyrene (EPS) products. Specification*
- *BS EN 13164 Thermal insulation products for buildings — Factory made Extruded Polystyrene foam (XPS) products Specification*
- *BS EN 13165 Thermal insulation products for buildings — Factory made rigid Polyurethane foam (PU) products. Specification*
- *BS EN 13166 Thermal insulation products for buildings — Factory made Phenolic Foam (PF) products — Specification*
- *BS EN 13167 Thermal insulation products for buildings — Factory made Cellular Glass (CG) products — Specification*
- *BS EN 13168 Thermal insulation products for buildings — Factory made wood wool (WW) products. Specification*
- *BS EN 13169 Thermal insulation products for buildings — Factory made expanded perlite board (EPB) products. Specification*
- *BS EN 13170 Thermal insulation products for buildings — Factory made products of expanded cork (ICB) — Specification*
- *BS EN 14783 Fully Supported Metal Sheet and Strip for Roofing External Cladding & internal lining — product specification & requirements*

Chapter

7.2



Pitched roofs

This chapter gives guidance on meeting the Technical Requirements for pitched roofs, including:

- coverings
- vertical tiling
- fixings
- ventilation
- weatherproofing.

7.2.1	Compliance	03
7.2.2	Provision of information	04
7.2.3	Design of pitched roofs	04
7.2.4	Protection of trusses	07
7.2.5	Durability	07
7.2.6	Wall plates	08
7.2.7	Joints and connections	09
7.2.8	Restraint	10
7.2.9	Bracing for trussed rafter roofs	11
7.2.10	Strutting for site formed attic trusses and cut roofs that form a floor	17
7.2.11	Support for equipment	17
7.2.12	Access	17
7.2.13	Dormer construction	18
7.2.14	Underlay, sarking boards and sheets	20
7.2.15	Ventilation, vapour control and insulation	21
7.2.16	Fire-stopping and cavity barriers	31
7.2.17	Battens	31
7.2.18	Roof coverings	33
7.2.19	Fixing tiles and slates	34
7.2.20	Weathering details	37
7.2.21	Valleys and hidden gutters	41
7.2.22	Drainage	42
7.2.23	Fascias and trim	42
7.2.24	Spandrel panels in cold roofs	43
7.2.25	Roof cassette systems	43
7.2.26	Solar roof panels	44
7.2.27	Further information	45

Figure reference table

Figure Reference Table 7.2

Fig No	Title/Description	Clause	Page
Figure 1	Trussed trimmed rafters	7.2.3.1	5
Figure 2	Traditional roof members	7.2.3.1	6
Figure 3	Pole plate	7.2.3.2	6
Figure 4	Types of rafter	7.2.3.2	6
Figure 5	Permissible truss projection	7.2.6	8
Figure 6	Rafter to ceiling joist connection	7.2.7	9
Figure 7	Rafter to purlin connection	7.2.7	9
Figure 8	Purlin connection	7.2.7	9
Figure 9	Scarf joint	7.2.7	9
Figure 10	Angle tie	7.2.7	9
Figure 11	Dragon tie	7.2.7	9
Figure 12	Dragon tie (alternative)	7.2.7	9
Figure 13	Diminishing truss supported by continuous binders	7.2.7	10
Figure 14	Diminishing truss supported on long battens	7.2.7	10
Figure 15	Lateral restraint strap secured to timber blocking	7.2.8	10
Figure 16	Lateral restraint strap secured to longitudinal bracing	7.2.8	10
Figure 17	Restraint by gable ladder — masonry	7.2.8	11
Figure 18	Roof bracing — lap joint	7.2.9.1	12
Figure 19	Roof bracing — wall plate connection	7.2.9.1	13
Figure 20	Diagonal rafter bracing — square roofs	7.2.9.2	13
Figure 21	Diagonal rafter bracing — larger roofs	7.2.9.2	13
Figure 22	Diagonal rafter bracing — narrow fronted roofs	7.2.9.2	13
Figure 23	Intersection detail	7.2.9.2	14
Figure 24	Longitudinal bracing — ridge node	7.2.9.2	14
Figure 25	Longitudinal bracing — rafter node	7.2.9.2	14
Figure 26	Longitudinal binders — ceiling node	7.2.9.2	14
Figure 27	Chevron bracing — duo pitched roof	7.2.9.2	14
Figure 28	Mono pitch truss — diagonal rafter bracing	7.2.9.3	15
Figure 29	Mono pitch truss — diagonal bracing to end vertical member	7.2.9.3	15
Figure 30	Mono pitch truss — longitudinal bracing	7.2.9.3	15
Figure 31	Mono pitch truss — chevron bracing	7.2.9.3	15
Figure 32	Attic truss — diagonal bracing	7.2.9.4	16
Figure 33	Attic truss — diaphragm bracing	7.2.9.4	16
Figure 34	Attic truss — diaphragm bracing	7.2.9.4	16
Figure 35	Attic truss — diaphragm bracing	7.2.9.4	16
Figure 36	Attic truss — longitudinal bracing	7.2.9.4	16
Figure 37	Dormer — rafter supported	7.2.13.1	18
Figure 38	Dormer — floor supported	7.2.13.1	18
Figure 39	Ventilation to dormer pitched roofs	7.2.13.2	19
Figure 40	Room-in-roof (flat cold roof dormer)	7.2.13.2	19
Figure 41	Underlay detailing	7.2.14	21
Figure 42	Typical eaves ventilation	7.2.15.1	22
Figure 43	Roof pitch 10° to 15°	7.2.15.1	24
Figure 44	Roof pitch >15° and <75°	7.2.15.1	24
Figure 45	Mono pitched roof	7.2.15.1	24
Figure 46	Hybrid roof — Room-in-roof	7.2.15.1	25
Figure 47	Hybrid roof — Room-in-roof (flat roof dormer)	7.2.15.1	25

Figure 48	Warm roof	7.2.15.1	25
Figure 49	Cold roof — Type LR underlay with air permeable covering	7.2.15.1	26
Figure 50	Warm roof — Type LR underlay with air permeable covering	7.2.15.1	27
Figure 51	Hybrid roof — Type LR underlay with air permeable covering	7.2.15.1	27
Figure 52	Cold pitched roof with flat roof apex	7.2.15.1	27
Figure 53	Cold roof — Type LR underlay with air impermeable covering	7.2.15.1	28
Figure 54	Warm roof — Type LR underlay with air impermeable covering	7.2.15.1	29
Figure 55	Hybrid roof — Type LR underlay with air impermeable covering	7.2.15.1	29
Figure 56	Ceiling penetrations	7.2.15.2	30
Figure 57	Storage tank insulation	7.2.15.4	30
Figure 58	Fire precautions	7.2.16	31
Figure 59	Incorrect batten jointing	7.2.17	32
Figure 60	Correct batten jointing — batten gauge >200mm	7.2.17	32
Figure 61	Correct batten jointing — batten gauge ≤200mm	7.2.17	32
Figure 62	Eaves detailing	7.2.19.1	35
Figure 63	Mechanically fixed ridge	7.2.19.1	35
Figure 64	Wet bedded ridge with dentil tiles	7.2.19.1	35
Figure 65	Wet verge	7.2.19.2	36
Figure 66	Verge — plain tiles	7.2.19.2	36
Figure 67	Wall abutment	7.2.20.1	38
Figure 68	Side abutment (double-lap clay or concrete plain tile and slate)	7.2.20.1	38
Figure 69	Side abutment gutter	7.2.20.1	38
Figure 70	Dry valley — lead saddle	7.2.20.2	39
Figure 71	Flat roof adjoining a pitched roof	7.2.20.2	39
Figure 72	Chimney — back gutter	7.2.20.3	39
Figure 73	Chimney penetration	7.2.20.3	39
Figure 74	Raking coping — masonry	7.2.20.4	40
Figure 75	Raking coping — framed structure	7.2.20.4	40

Definitions for this chapter

Air impermeable weatherproof covering	A roof covering where the airflow through it is not greater than $17.4 A_f$ (in m^3/h).
Air permeable weatherproof covering	A roof covering where the airflow through it is greater than $17.4 A_f$ (in m^3/h).
Air and vapour control layer (AVCL)	A continuous layer to restrict the movement of air and water vapour.
Cavity barrier	A construction within a cavity, other than a smoke curtain, to either close a cavity to stop smoke or flame entering, or restrict the movement of smoke or flame within a cavity.
Coastal locations	A site within a distance of 500m from the general coastline of the United Kingdom.
Cold pitched roof	A roof where the insulation is laid horizontally at ceiling level and the space above is unconditioned.
Complex roof	Large span roofs of over 12m, or roofs with complex geometry and/or features.
Conditioned space	Occupied space in which the temperature and humidity are controlled.
Fire-stopping	Fire-stopping is a seal provided to close an imperfection of fit or design tolerance between elements or components, to restrict the spread of fire and smoke.
Hybrid roof	A roof where the insulation is positioned partly on a horizontal ceiling, vertical members and partly at the rafter line.
Normal ceiling	A ceiling with a typical air permeability of $300mm^2/m^2$ (0.3%).
Perimeter roofing element	The single roofing element (eg tile, slate, shingle) at any discontinuity in the plane of the roof, including roof windows, dormers, valleys, roof edges, etc.
Pitched roof	Part of the external envelope of a building that is at an angle between 10° and 70° .
Sarking board	Softwood timber boards, fixed over the rafters of a pitched roof, used for the purposes of roof bracing (boards may be tongue and grooved or open jointed).
Sarking sheet	Tightly jointed sheet boards, fixed over the rafters of a pitched roof, used for the purposes of roof bracing (eg OSB, exterior grade plywood, etc).
Solar roof panel	Either solar photovoltaic (PV) or thermal roof panels, and either 'on-roof' type or integrated into the roof covering.
Type HR underlay	A membrane with a high water vapour resistance, s_d , greater than 0.05m (0.25 MN·s/g).
Type LR underlay	A membrane with a low water vapour resistance, s_d , not exceeding 0.05m (0.25 MN·s/g).
Unconditioned space	Unoccupied space in which the temperature and humidity are not controlled.
Warm pitched roof	A roof where the insulation follows the rafter line.
Well-sealed ceiling	A ceiling with a typical air permeability of not more than $30mm^2/m^2$ ($\leq 0.03\%$).

7.2.1 Compliance

Also see: Chapter 2.1

Pitched roof structures and coverings shall comply with the Technical Requirements.

Pitched roofs that comply with the guidance in this chapter will generally be acceptable.

Roofs with a tile or slate covering should be in accordance with BS 5534.

7.2.2 Provision of information

Designs and specifications shall be produced in a clearly understandable format, include all relevant information and be distributed to the appropriate personnel.

Design and specification information for traditional cut roofs and roof trusses should be issued to site supervisors, relevant specialist subcontractors and suppliers, and include the following information:

- the layout of cut roofs, trusses and associated items
- details of mono pitched, lean-to roofs and roof intersections (ie, hips and valleys)
- details of girder trusses, multiple trusses and diminishing trusses, including how they are to be fixed together and supported on truss shoes, layboards or similar
- details of bracing requirements
- details of supports for equipment in the roof space
- the type and position of AVCLs
- details of restraint/holding-down strapping, including coatings and fixings
- the types, position and thickness of insulation
- the means of providing ventilation
- details of fire-stopping at separating wall and boxed eaves
- details of coverings and fixings, including number and type
- details of flashing details at abutments, chimneys, etc
- details of trimming around chimneys, access hatches, etc
- details of loose rafter and floor joist trimming arrangements around staircases, dormer roofs, etc where attic trusses are used.

For trusses, the design should be provided to the manufacturer in accordance with PD 6693-1, which includes:

- usage, height and location of building, referencing any unusual wind conditions
- rafter profile, referencing camber where required
- spacing, span and pitches
- method of support and position of supports
- type and weight of coverings, including sarking, insulation and ceiling materials
- eaves overhang and other eaves details
- size and approximate position of water tanks or other equipment to be supported
- positions and dimensions of hatches, chimneys and other openings
- type of preservative treatment, where required
- special timber sizes, where required to match existing construction.

7.2.3 Design of pitched roofs

Also see: BM TRADA Eurocode 5 span tables (4th Edition) and BS 8103-3

The sizing and spacing of members shall ensure structural stability and provide restraint to the structure without undue movement or distortion. Issues to be taken into account include:

1) trussed rafter roofs

The design of pitched roofs should:

- have dead, imposed and wind loads calculated in accordance with BS EN 1991-1-1, BS EN 1991-1-3 and BS EN 1991-1-4
- be in accordance with PD 6693-1, and Technical Requirement R5, where appropriate
- be appropriate for the location, accounting for exposure and wind uplift
- ensure that the structure is coherent and that all forces are resolved
- ensure the deflection of floors formed by the bottom chords of attic trusses are in accordance with the requirements of Clause 6.4.9

Roofs should be designed by an engineer in accordance with Technical Requirement R5 where:

- the roof is not a basic pitched roof
- hips, valleys or other special features are included in a trussed rafter roof
- the spans, sizes, spacing or strength classes of the timber are outside the scope of authoritative tables
- ensure that where raised collar trusses are used, as part of the room-in-roof construction, the horizontal deflection of the trusses at the supports should be no more than +/- 6mm
- ensure stability with the complete structure, including the connections and compatibility with the supporting structure and adjacent elements
- ensure that the full extent of detailing and connections are included where trussed rafters and a cut roof are combined.
- trussed rafters support traditional cut roof members, or
- it is a proprietary system (designs supplied by manufacturers will generally be acceptable).

Structural timber components should be of a suitable strength class as specified by the designer to BS EN 338. Solid structural timber should be:

- machine graded to BS EN 14081, or visually graded to BS 4978 for softwoods or BS 5756 for hardwoods
- assigned a strength class based on BS EN 1912 when visually graded
- dry graded
- marked in accordance with BS EN 14081.

Further guidance on strength classes for certain timber species can be found in PD 6693-1.

Engineered wood products such as I-section or metal-web studs, joists and rafters should be assessed in accordance with Technical Requirement R3.

7.2.3.1 Trussed rafter roofs

Trussed rafters should be:

- installed in accordance with the design, and the structure or spacing should not be altered without prior consent from the designer
- fixed to the wall in accordance with the design (eg using double skew nailing or truss clips)
- vertical and suitably located (where necessary, temporary bracing should be used to maintain spacing and to keep trusses vertical)
- evenly spaced at maximum 600mm centres.

Where the maximum 600mm spacing cannot be achieved, eg to accommodate hatch openings or chimneys, spacing may be increased to a maximum of twice the nominal spacing, provided that the spacing X is less than, or equal to, $2A-B$ where:

- X = distance between centres of trussed trimmed rafters and the adjacent trussed rafter
- A = design spacing of trussed rafters
- B = nominal width of opening.

Where multiple and reinforcing timbers to simple or multiple trussed rafters are used, they should be:

- designed to be permanently fastened together
- either fixed together during manufacture, or fully detailed drawings and specifications showing the fixing method should be supplied.

Hipped roofs constructed with trussed rafters typically require a series of diminishing mono pitched trusses supported by a girder truss.

The bearing of mono pitched trusses into shoes should be in accordance with Table 1, unless designed by an engineer in accordance with Technical Requirement R5.

Figure 1: Trussed trimmed rafters

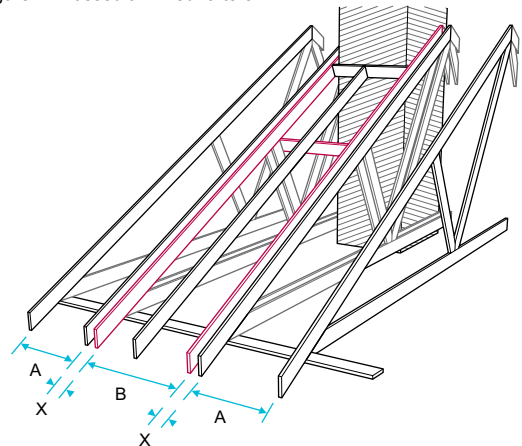

Table 1: Bearing length of mono pitched trusses into shoes

Span	Minimum bearing length	Minimum thickness of trussed rafter
Less than 4m	50mm	35mm
4m or more	75mm	35mm

Ceiling finishes should be fixed according to the spacing of the support members and the thickness of the sheet. Plasterboard should be fixed as follows:

- 9.5mm plasterboard should be fixed at a maximum support spacing of 450mm
- 12.5-15mm plasterboard should be fixed at a maximum support spacing of 600mm
- additional members will generally be required to support coverings and finishes where trusses are spaced further apart.

Where the width of a gable ladder exceeds that of the trussed rafter centres, noggings should be used to reduce the span of the roofing tile battens.

7.2.3.2 Traditional cut roofs

For traditional cut roofs:

- the design should specify the details of each structural member and the method of fixing or jointing
- the roof should be in accordance with the design, and members accurately located
- members should be fully supported and tied together where necessary, particularly where the roof is not a simple triangle
- temporary support to long span members should be used until framing is complete
- purlins and binders should be built in where necessary
- framing should be completed before coverings are installed.

Table 2: Basic timber members

Member	Notes
Valley rafter	Provides support for loads from both sections of the roof and should: <ul style="list-style-type: none"> • be larger than ordinary rafters to take the additional load • provide full bearing for the splay cut of jack rafters • be provided with intermediate support where required
Hip rafter	Provides spacing and fixing for jack rafters and should have a deeper section than the other rafters to take the top cut of the jack rafters. Purlins should be mitred at hips and lip cut to accept the bottom of the hip rafter
Ceiling joist or ties	Provides support for the rafters and should: <ul style="list-style-type: none"> • stop the walls and roof spreading outwards • provide support to the ceiling finish and walkways, etc
Ridge	Provides fixings and spacing for the tops of the rafters
Purlin	Provides support to long span rafters to prevent deflection and increase stiffness
Struts	Provides support to purlins to prevent deflection and to transfer roof loads to the load-bearing structure below
Collar	Ties the roof together at purlin level
Ceiling binders and hangers	Provides support to long span ceiling joists
Pole plates	Similar to purlins, but used where ceiling joists are above wall plate level

Figure 2: Traditional roof members

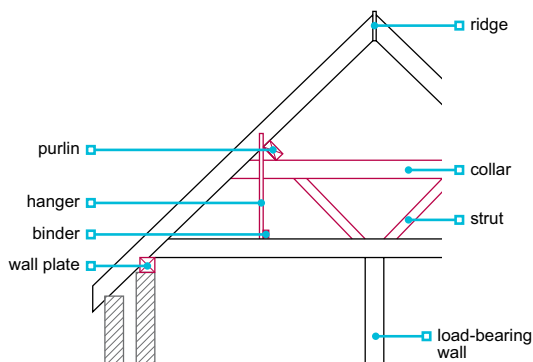
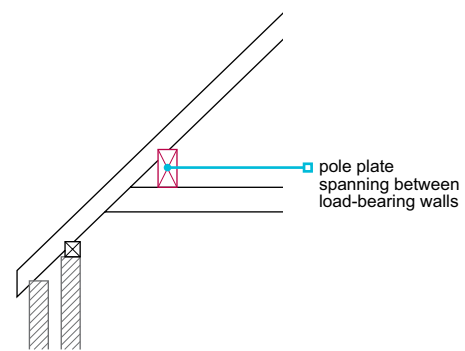

Figure 3: Pole plate



Generally, sizes should be as shown in Table 3, unless designed by an engineer in accordance with Technical Requirement R5.

Table 3: Typical sizes for timber members

Member	Minimum size
Struts	100mm x 50mm
Valley rafter	32mm thick
Ridges and hips	Rafter cut + 25mm

Figure 4: Types of rafter

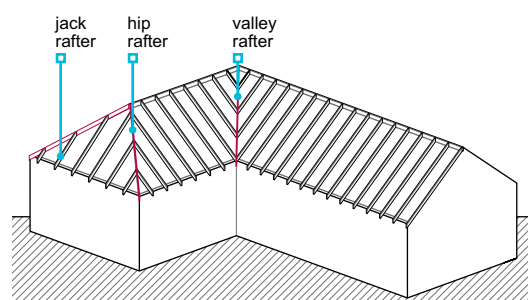

7.2.4 Protection of trusses

Also see: *Trussed Rafter Association Technical Handbook*

Trusses shall be protected from damage.

To avoid distortion and to prevent damage, trusses should be:

- protected against weather to prevent the corrosion of truss plates and the deterioration of the timber
- adequately ventilated during storage
- stored clear of the ground
- stored vertically and propped
- stored with level bearers under the joints
- carried upright (fasteners can loosen when carried flat).

Trussed rafters should not be cut, modified or repaired, except in accordance with written or drawn instructions issued and approved by the trussed rafter designer.

7.2.5 Durability

Also see: *Chapter 3.3*

Timber shall be of suitable durability.

The following timber members should be preservative treated or have adequate natural durability in accordance with Chapter 3.3 Timber preservation (natural solid timber):

Table 4: Durability options for the following components

	Preservative treatment			Naturally durable species
	Treatment required	Use Class	Desired service life (years)	Select timber from a minimum natural durability class ⁽¹⁾ (heartwood only)
Porch posts	✓	3.1/3.2	30	3/2
Tiling battens	✓	2	60	2
Soffits	✓	3.1/3.2	30	3/2
Barge boards	✓	3.1/3.2	30	3/2
Fascias	✓	3.1/3.2	30	3/2

Note

1. Where natural durability is used in lieu of preservative treatment, timber must be specified and selected as heartwood only. Natural durability classes for the heartwood of commonly used timbers are available in BS EN 350 and Table 2 in Chapter 3.3.

Where the pitched roof is to include a fully supported weatherproofing membrane (ie, impervious coverings such as single ply membranes, bituminous membranes, etc) or continuous metal coverings, the risk of condensation is increased. The timber components listed in Table 5 should be preservative treated or have adequate natural durability.

Table 5: Durability options where fully supported weatherproofing membranes and continuous metal coverings are used

	Preservative treatment			Naturally durable species
	Treatment required	Use Class	Desired service life (years)	Select timber from a minimum natural durability class ⁽¹⁾ (heartwood only)
Rafters/ trussed rafters	✓	2	60	2
Purlins	✓	2	60	
Ceiling joists	✓	2	60	
Bracings	✓	2	60	
Wall plates	✓	2	60	
Battens	✓	2	60	

Note

1. Where natural durability is used in lieu of preservative treatment, timber must be specified and selected as heartwood only. Natural durability classes for the heartwood of commonly used timbers are available in BS EN 350 and Table 2 in Chapter 3.3.

7.2.6 Wall plates

Wall plates and the roof structure shall be bedded and fixed to distribute and transmit loads, and to prevent uplift.

Trussed rafter roofs and traditional cut roofs should be supported on timber wall plates. Trussed rafters should only be supported at the junction between the ceiling tie and rafter, unless specifically designed otherwise, eg as a cantilever.

Wall plates should be:

- bedded to line and level
- fixed using nails or straps
- a minimum of 3m or extend over at least three joists, rafters or trusses
- joined using half-lapped joints, including at corners
- 38 x 100mm or in accordance with local practice.

Fixings used to connect the roof structure to the wall plate should be specified according to the roof construction and exposure of the site.

Where trussed rafter roofs are not subject to uplift, a minimum of two 4.5mm x 100mm galvanised round wire nails, skew nailed, one on each side of the trussed rafter, or truss clips (fixed in accordance with the manufacturer's instructions) are acceptable.

Where the roof is required to resist uplift, skew nailing is unlikely to provide sufficient strength, and appropriate metal straps should be used. Holding-down straps should be:

- provided according to the geographical location and construction type
- provided where the self-weight of the roof is insufficient against uplift
- provided in accordance with the design
- a minimum of 1m long with a cross section of 30mm x 2.5mm and spaced at a maximum of 2m centres (galvanised steel straps are generally acceptable), or proprietary straps and fixings
- fixed to the wall, or turned into a bed joint.

Fixings for straps should be:

- in accordance with the design
- of a material or finish which is compatible with the straps
- where into masonry, a minimum of four, 50mm long No.12 wood screws (into suitable plugs)
- provided so that the lowest fixing is within 150mm from the bottom of the strap.

Proprietary straps should be:

- in accordance with Technical Requirement R3
- installed in accordance with the manufacturer's recommendations.

Figure 5: Permissible truss projection

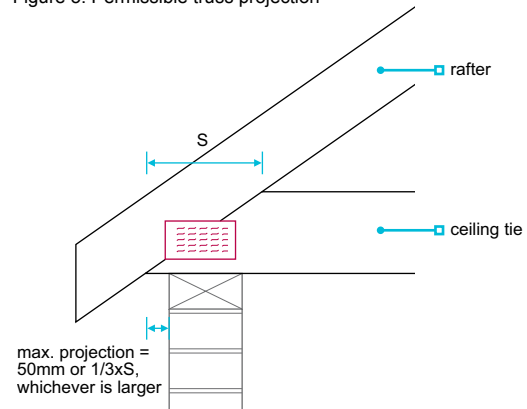

7.2.7 Joints and connections

Joints and connections shall be designed to ensure structural stability without undue movement or distortion.

Members should:

- be accurately cut to fit tightly
- not be damaged or split.

The following joints should be used at the main connections of traditional cut roof members:

Rafters to ceiling joists using a nailed lapped joint

The rafter should be birdsmouthed and skew nailed to the wall plate.

Figure 6: Rafter to ceiling joist connection

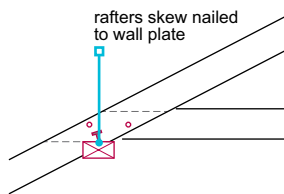

Rafter to purlin

A birdsmouth joint should be used; generally, the purlin is fixed vertically.

Figure 7: Rafter to purlin connection

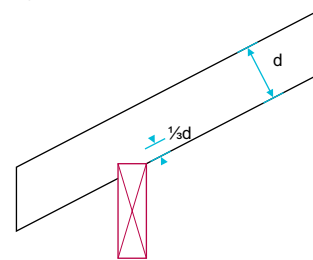

Purlin connections

Support should be provided directly under the joint or a scarf joint used. Scarf joints should be made near to a strut so that the joint supports the longer span.

Figure 8: Purlin connection

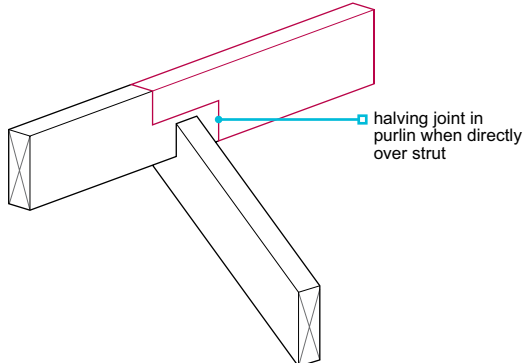

Scarf joint

Used to support the long span of the purlin.

Figure 9: Scarf joint

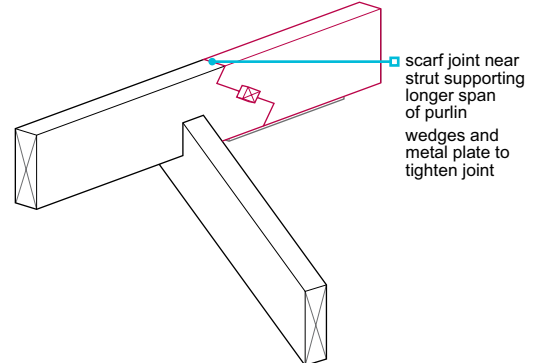

Hipped roof joints

Angle ties should be used at the corners of hipped roofs to prevent the wall plates from spreading.

Where hip rafters are heavily loaded, eg carrying purlins, they should be jointed using dragon ties, or similar, to prevent the hip rafter spreading.

Figure 11: Dragon tie

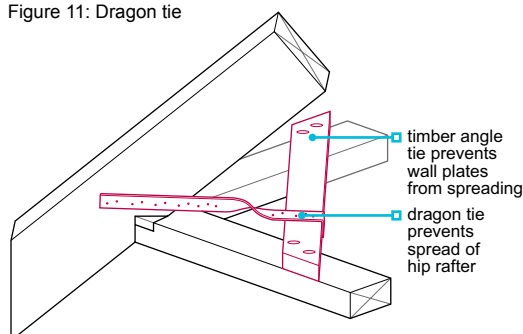

Figure 10: Angle tie

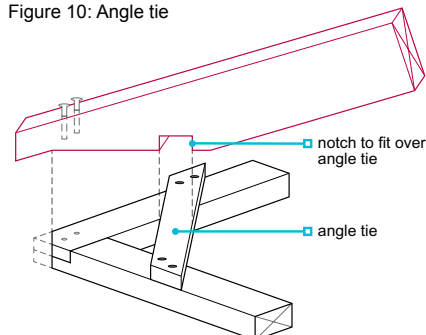
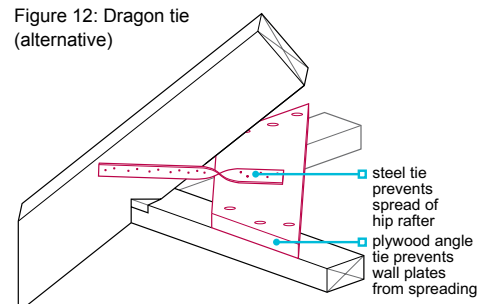

Figure 12: Dragon tie (alternative)



Diminishing truss support

Diminishing trusses should be adequately supported by one of the following:

- a splayed bottom chord to ensure correct seating on the rafter, or
- by sitting on a continuous binder which is splayed to receive the diminishing truss (Figure 13), or
- by sitting on 25mm x 38mm x 300mm long battens which are splayed to receive the diminishing truss (Figure 14), or
- proprietary diminishing support brackets assessed in accordance with Technical Requirement R3.

Figure 13: Diminishing truss supported by continuous binders

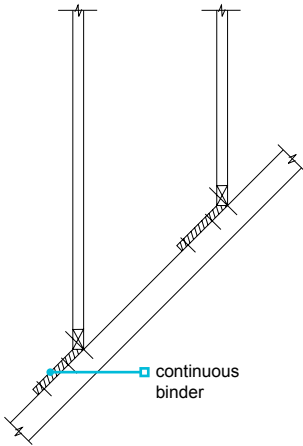
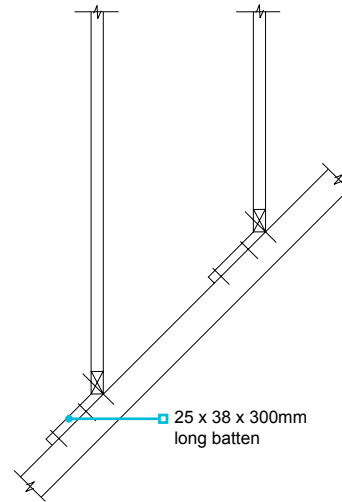

Figure 14: Diminishing truss supported on long battens



7.2.8 Restraint

Also see: Chapter 6.1

Adequate restraint shall be provided to support the structure, distribute roof loads and prevent wind uplift. Strapping shall be of adequate strength and durability, and fixed using appropriate fixings.

Restraint straps, or a restraining form of gable ladder, should be used where required to provide stability to walls, and be installed in accordance with the design.

Lateral restraint straps should be located:

- for homes up to and including three storeys (two storeys in Scotland), at a maximum spacing of 2m
- for homes four storeys (three storeys in Scotland) or over, fixed at a maximum spacing of 1.25m.

Lateral restraint straps should be fixed to the roof structure by either:

- fixing to solid noggings using a minimum of four 50mm x 4mm steel screws or four 75mm x 4mm (8SWG) round nails, with one fixing in the third rafter (Figure 15), or
- fixing to longitudinal bracing members using eight 25mm x 4mm steel screws evenly distributed along the length of the strap (Figure 16) — alternatively, 100mm x 25mm timber members, fixed over four trusses and nailed in accordance with Clause 7.2.9, can be used where the position of the strap does not coincide with a longitudinal binder.

Figure 15: Lateral restraint strap secured to timber blocking

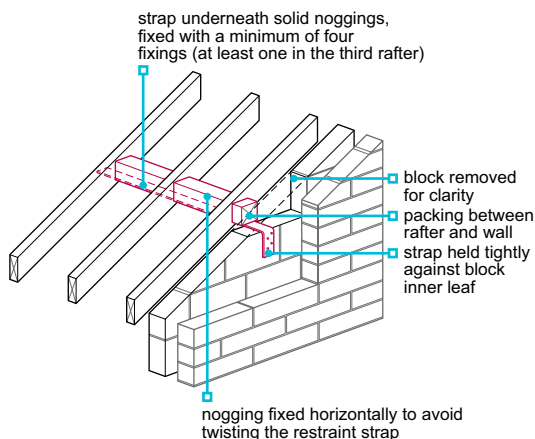
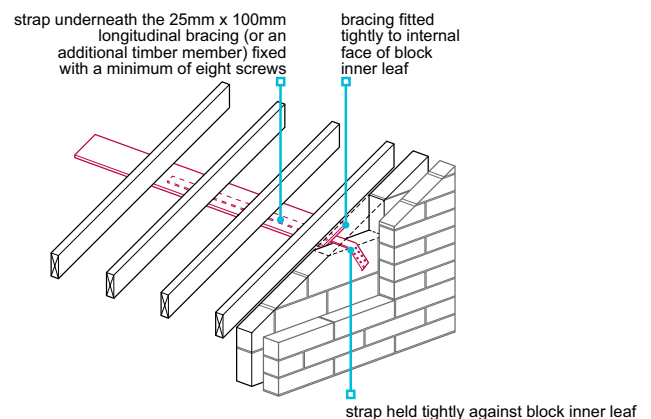

Figure 16: Lateral restraint strap secured to longitudinal bracing



Lateral restraint straps should be:

- ordered and supplied according to the design ie, the correct length and number of bends and twists
- provided at rafter level on gable walls, where the home is of masonry construction (larger or separating walls may require restraint at ceiling level)
- protected against corrosion in accordance with BS EN 845-1 Clause 6.1.11 Table 4 (sherardised straps or fixings are not acceptable in Northern Ireland and the Isle of Man)
- of sufficient length to be fixed to a minimum of three trusses
- a minimum size of 30mm x 5mm and have a minimum anchorage downturn to 100mm (or proprietary straps)
- fixed with the downturn on a substantial piece of blockwork, preferably fitted over the centre of an uncut block
- in accordance with BS EN 1995-1-1, where the home is of timber frame construction.

In framed roofs, as an alternative, purlins and pole plates can be used to provide restraint where the timber abuts a gable construction. Where purlins are used to provide restraint, the maximum permissible spacing is 2m, unless the design shows otherwise.

Gable ladders can also be used to provide restraint to the external wall where:

- forming part of the structural design
- there is blocking between the last trussed rafter and the inner leaf (maximum 2m spacing) or the longitudinal bracing is in contact with the inner leaf (maximum 2m spacing) — additional intermediate boards may need to be provided, where bracings are more than 2m apart and where homes are four storeys (three storeys in Scotland) or over
- the soffit board is cut carefully and then fixed securely to restrain the outer leaf.

Proprietary straps should be:

- in accordance with Technical Requirement R3
- installed in accordance with the manufacturer's recommendations.

Figure 17: Restraint by gable ladder — masonry

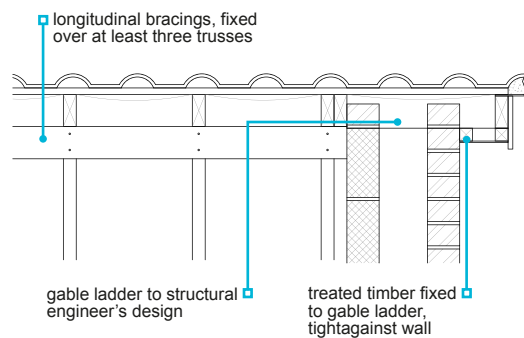

7.2.9 Bracing for trussed rafter roofs

Also see: BS EN 1995-1-1 and PD 6693-1

Trussed rafters shall be suitably braced to support applied loads and self-weight without undue movement. Issues to be taken into account include:

- 1) general bracing requirements
- 2) duo pitched roofs
- 3) mono pitched roofs
- 4) attic roofs.

For the purposes of this chapter, the guidance and use of standard trussed rafter bracing applies to all homes designed within the parameters set out below. For large houses with truss spans of over 12m, homes with complex roofs or roofs near exposed sites, the bracing should be designed by an engineer in accordance with Technical Requirement R5.

Standard trussed rafter bracing, in accordance with Table 6, is generally acceptable, where the home:

- has a rectangular roof (including hip ends) and is either a duo pitched or a mono pitched structure
- is not taller than 8.4m (to the underside of the ceiling tie)
- is braced in accordance with this chapter
- is braced according to the conditions of the site and in accordance with the design
- does not have trusses which span more than 12m
- has trusses which are only supported at each end
- does not have unsupported masonry spanning more than 9m (between buttressing walls, piers or chimneys)
- has a ceiling of plasterboard directly under each truss (where there is no plasterboard ie, garages, additional diagonal ceiling bracing and longitudinal binder bracing at each ceiling node point is required).

Table 6: Location, height and span for standard bracing conditions for buildings at site altitudes ≤150m

	Roof type		Duo pitch						Mono pitch								
	Max pitch		35°			30°			35°			30°			25°		
	Storeys		1	2	3	1	2	3	1	2	3	1	2	3	1	2	3
Maximum span (m)	England ⁽¹⁾ and Wales ⁽¹⁾	Wind zone A ⁽²⁾	11.3	9.3	8.9	12	11.6	10.5	5.7	3.0	4.5	6.9	5.9	5.3	8.5	7.2	6.6
	Scotland ⁽¹⁾ up to Glasgow and Aberdeen	Wind zone B ⁽²⁾	9.4	8.1	7.6	11.6	10.2	9.1	5.0	4.0	3.8	5.9	5.2	4.5	7.2	6.4	5.7
	Scotland ⁽¹⁾ up to Oban and Inverness	Wind zone C ⁽²⁾	8.7	6.9	6.4	10.3	8.9	7.8	4.4	3.7	3.2	5.2	4.5	3.9	6.5	5.7	5.0
	Scotland ⁽¹⁾ areas north of Isle of Mull and Broro	Wind zone D ⁽²⁾	7.7	6.4	5.4	9.1	7.8	6.7	3.8	3.2	2.7	4.5	3.9	3.3	5.8	5.0	4.0
	Northern Ireland ⁽¹⁾ and the Isle of Man	Wind zone B ⁽²⁾	9.4	8.1	7.6	11.6	10.2	9.1	5.0	4.0	3.8	5.9	5.2	4.5	7.2	6.4	5.7
	Northern Ireland ⁽¹⁾ areas north west of Ballymena	Wind zone C ⁽²⁾	8.7	6.9	6.4	10.3	8.9	7.8	4.4	3.7	3.2	5.2	4.5	3.9	6.5	5.7	5.0

Notes

1. For details of area specific wind zoning, please refer to PD6693-1.
2. Wind zones in accordance with PD6693-1.

Where trussed rafter designs are outside the parameters above, the guidance in PD6693-1 should be followed.

7.2.9.1 General bracing requirements

Roof bracing should be:

- in accordance with this chapter or PD6693-1
- in accordance with the design and not altered without prior approval from the designer
- appropriate for the site (for large houses with truss spans of over 12m, homes with complex roofs or roofs near exposed sites, the bracing should be designed by an engineer in accordance with Technical Requirement R5)
- completed before the roof covering is laid
- provided using a minimum timber size of 100mm x 25mm (3mm tolerance)
- nailed twice to each rafter it crosses; fixings should be 3.35mm x 65mm (10 gauge) galvanised round wire nails or minimum 3.1mm x 75mm mechanically driven gun nails
- where braces and binders are not continuous, they should be lap jointed and nailed to a minimum of two trusses.

Figure 18: Roof bracing — lap joint

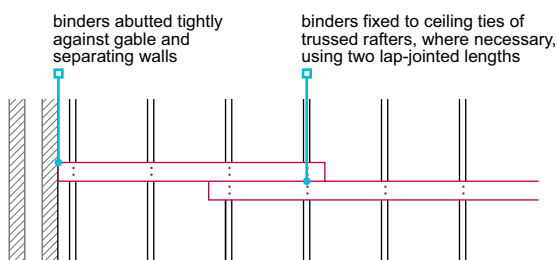

When bracing pitched roofs:

- diagonal and longitudinal bracing should be provided at rafter level (this may be omitted where sarking sheets or boards are used, eg chipboard, plywood or OSB, which are fixed to each trussed rafter with 3mm x 50mm galvanised round wire nails at 200mm spacing)
- diagonal and chevron bracing should pass across each rafter in the roof; however, small gaps, such as two trussed rafters between sets of bracing, or one trussed rafter adjacent to gable or separating walls, is permitted in the middle of an otherwise fully braced roof
- longitudinal bracing members should extend the full length of the roof, tightly abut gable and party walls, and permit diagonal bracing to pass (they may be lap jointed, providing the overlap is nailed to a minimum of two trussed rafters)
- there should be a minimum of four diagonal rafter braces in each roof; in narrow fronted roofs (Figure 22) and mono pitched roofs, where the braces cross, the intersection detail (Figure 23) should be used
- the diagonal bracing should extend over and be directly fixed to the wall plate, fixings should be 3.35mm x 65mm (10 gauge) galvanised round wire nails or minimum 3.1mm x 75mm mechanically driven gun nails (see Figure 19) — where the bracing cannot be directly fixed to the wall plate the bracing should be terminated as detailed in PD6693-1:2019, Figure E.9.

Figure 19: Roof bracing — wall plate connection

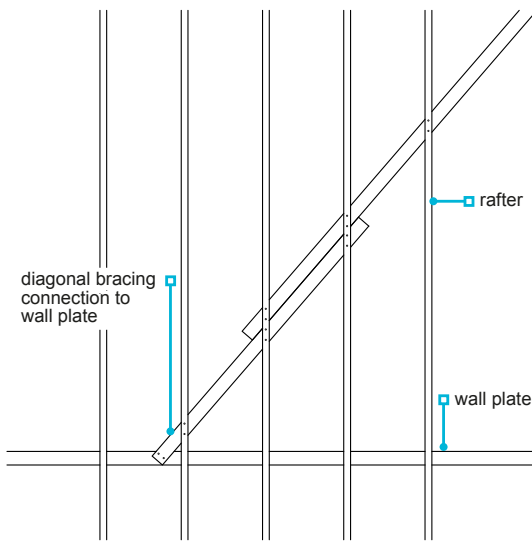

7.2.9.2 Duo pitched roofs

Diagonal bracing for duo pitch trusses

Applicable to all trussed rafter roofs, unless sarking sheets or boards are used.

Diagonal bracing should also be provided in-between hipped ends, where the length of roof between the hip ends exceeds 1.8m.

Diagonal rafter bracing should be approximately 45° to the rafters on plan.

Figure 20: Diagonal rafter bracing — square roofs

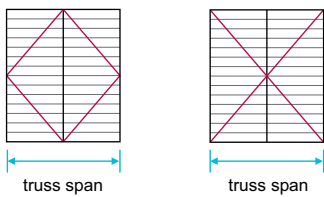

Figure 21: Diagonal rafter bracing — larger roofs

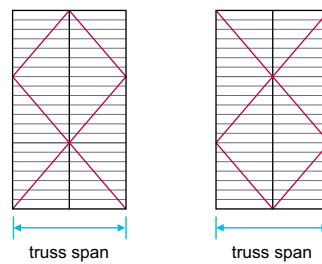
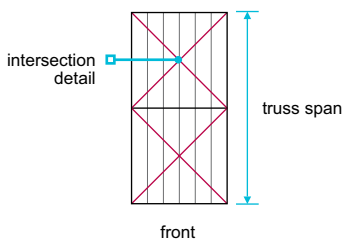

Figure 22: Diagonal rafter bracing — narrow fronted roofs



Intersection details should be formed by:

- 22mm x 97mm x 600mm timber splice plate
- nailing, using a minimum of four 3.35mm x 65mm galvanised round wire nails or minimum 3.1mm x 75mm mechanically driven gun nails to each side of the intersection, with nails driven through bracing and clenched over.

Figure 23: Intersection detail

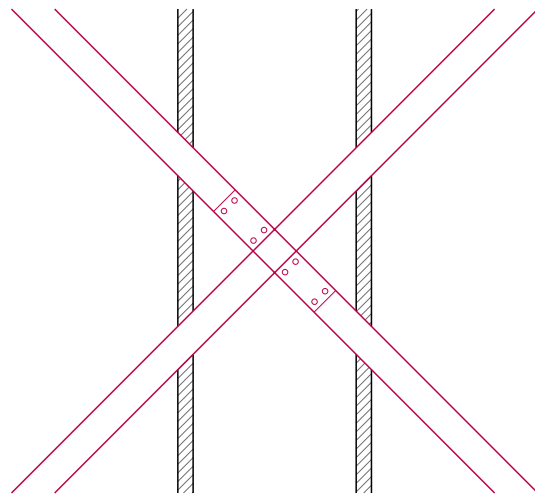

Longitudinal bracing member at ridge node point

Applicable to all trussed rafter roofs. Not necessary where sarking sheets or boards are used.

Figure 24: Longitudinal bracing — ridge node

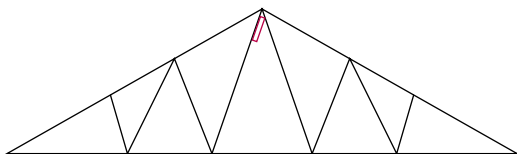

Longitudinal bracing member at rafter node point

Applicable to all rafter node points. Not necessary where:

- spacing between braced nodes is less than 4.2m, or
- sarking sheets or boards are used.

Figure 25: Longitudinal bracing — rafter node

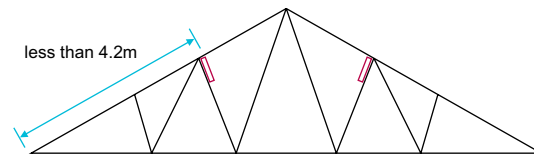

Longitudinal binders at ceiling node points

Applicable to all ceiling node points. Not necessary where the spacing between braced nodes is less than 3.7m.

Figure 26: Longitudinal binders — ceiling node

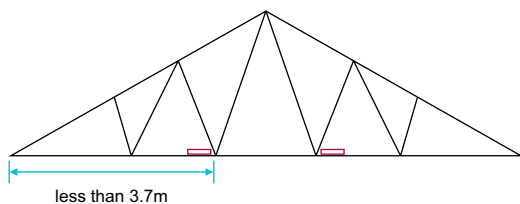

Chevron bracing between webs

Chevron bracing should be:

- provided where the span exceeds 8m
- at approximately 45°
- nailed to at least three trusses.

Figure 27: Chevron bracing — duo-pitched roof

KEY:

- chevron bracing position where span exceeds 8m
- additional chevron bracing position where span exceeds 11m

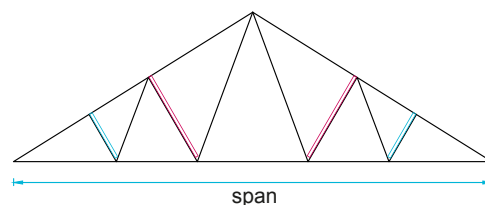

For duo pitched roofs over 11m span, chevron bracing should be designed by an engineer in accordance with Technical Requirement R5.

7.2.9.3 Mono pitched roofs

Diagonal bracing for mono pitch trusses

Applicable to all mono pitched trussed rafter roofs, unless sarking sheets or boards are used.

Diagonal rafter bracing should be approximately 45° to the rafters on plan.

Figure 28: Mono pitch truss — diagonal rafter bracing

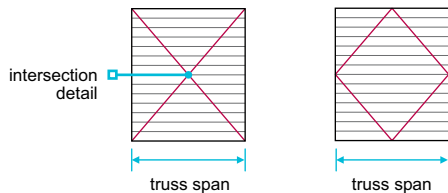

Longitudinal bracing to mono pitch trusses

Longitudinal bracings should be located at the apex and either:

- all other node points (excluding support points), or
- where intermediate longitudinal bracing members are omitted, the resultant spacing between longitudinal braced node points does not exceed 4.2m measured along each rafter and 3.7m measured along each ceiling tie.

Figure 30: Mono pitch truss — longitudinal bracing

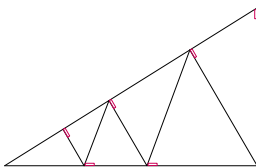

Diagonal bracing to end vertical member of mono pitch trusses

Applicable where the truss is not restrained by:

- a masonry wall, or
- cladding ie, plywood.

Figure 29: Mono pitch truss — diagonal bracing to end vertical member

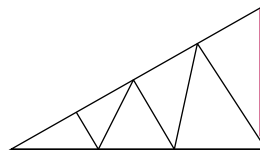

Chevron bracing between webs

Chevron bracing should be:

- provided where the span exceeds 5m
- at approximately 45°
- nailed to at least three trusses.

Figure 31: Mono pitch truss — chevron bracing

KEY:

- chevron bracing position where span exceeds 5m
- additional chevron bracing position where span exceeds 8m

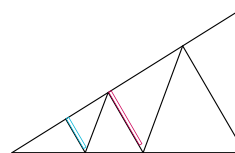

For mono pitched roofs over 8m span, chevron bracing should be designed by an engineer in accordance with Technical Requirement R5.

7.2.9.4 Attic roofs

Attic trusses should be braced in accordance with the design.

Diagonal bracing

Applicable to all attic trussed rafter roofs, unless sarking sheets or boards are used.

Diagonal bracing is required:

- at each gable end at approximately 45° on plan
- at intervals along the roof to ensure each truss is braced
- to be fixed to the underside of the rafters (where diagonal bracing passes through the room space, ceiling boards can be fixed over the diagonal bracing onto battens fixed to the rafters on each side of the bracing).

Diaphragm bracing

Where the diagonal bracing passes through the room space and needs to be interrupted to allow boarding to be fixed without battening out the rafters, the following options may be used:

- continuous internal 9mm plywood or OSB sheathing (see Table 9) minimum 900mm width, as shown in Figure 33, face fixed to the underside of the rafters for the full length of the roof, or
- diaphragm bracing closely fitted between the rafters as shown in Figure 34 and Figure 35 (the bracing should be 9mm plywood or OSB sheathing (see Table 9), at least 1200mm long fixed to a 50mm x 50mm timber framework).

Figure 34: Attic truss — diaphragm bracing

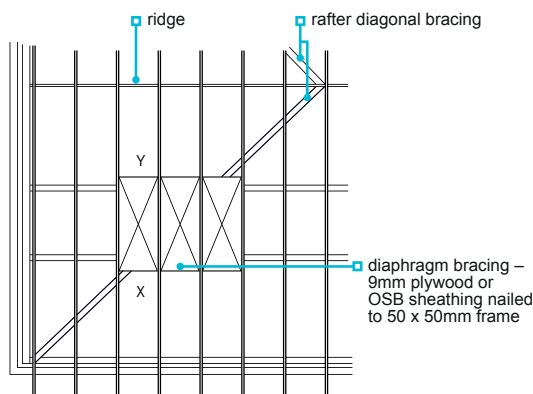

Longitudinal bracing

Longitudinal bracing is required at node points (excluding support points).

Figure 32: Attic truss — diagonal bracing

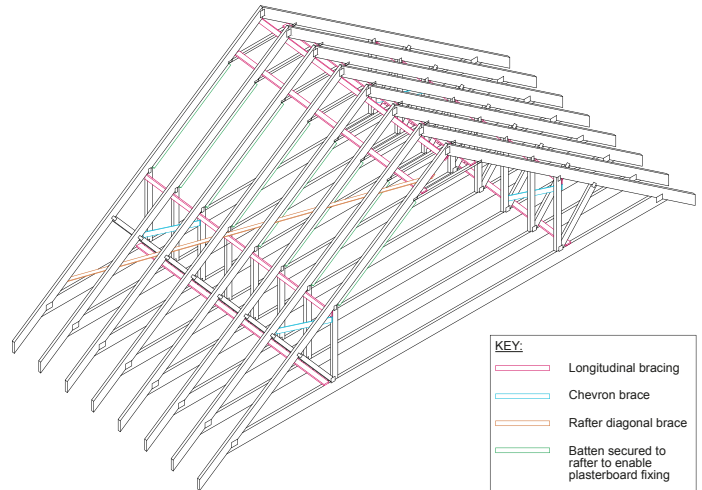

Figure 33: Attic truss — diaphragm bracing

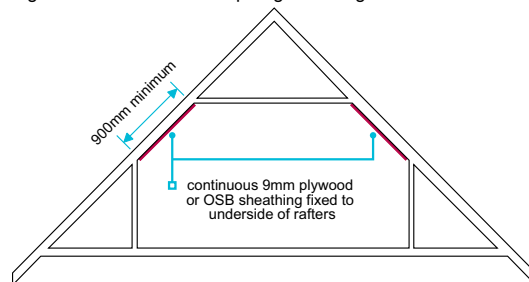

Figure 35: Attic truss — diaphragm bracing

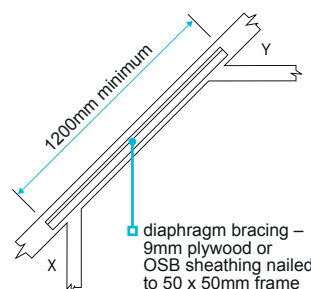
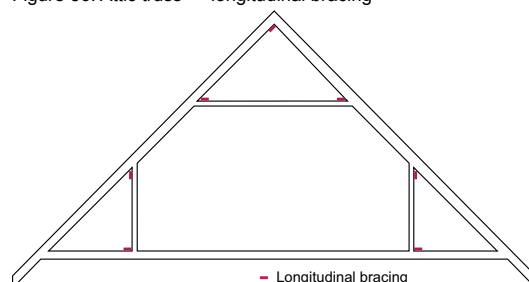

Figure 36: Attic truss — longitudinal bracing



Also see: Chapter 6.4

7.2.10 Strutting for site formed attic trusses and cut roofs that form a floor

Strutting to site formed attic trusses shall be provided to support the applied loads and self-weight without undue movement or distortion.

Strutting should be provided:

- in accordance with the design
- where the span between the node points which form the width of the floor of the attic truss exceeds 2.5m
- where the span between the supports to a floor within a cut roof exceeds 2.5m
- using herringbone (38mm x 38mm timber) or solid strutting (a minimum of 0.75x the depth of the floor and a minimum of 38mm thick).

Table 7: Provision of strutting

Span of floor	Rows of strutting
Under 2.5m	None required
2.5m – 4.5m	One (at centre of span)
Over 4.5m	Two (at equal spacing)

7.2.11 Support for equipment

Permanent equipment in roof voids shall be adequately supported.

Where equipment (eg water tanks and Mechanical Ventilation Heat Recovery (MVHR) fan units) is located in the roof void, the structure should be designed in accordance with PD 6693-1 and the truss manufacturer's recommendations, to support the additional load. Platforms supporting permanent equipment should be positioned with a minimum clearance of 50mm between the top of the insulation and the underside of the platform, to ensure a clear ventilation space.

7.2.12 Access

Also see: Clause 7.2.15

Roof voids shall be provided with suitable access.

Access to roof voids should be provided to allow for periodic inspection, maintenance and removal of permanent equipment.

Access should:

- be designed in accordance with PD 6693-1 and the truss manufacturer's recommendations to support the additional load
- be provided to the main roof space and to voids which contain permanent equipment (eg heating, water storage, energy producing and ventilation equipment, etc), service connection boxes or connection points for TV aerials, etc
- permit the removal of permanent equipment located in the roof space
- have a minimum opening width of 520mm in each direction
- not be located directly over stairs or in other hazardous locations
- include boarded walkways between the opening and the maintenance platform (a minimum 1m² platform should be provided at the location of any permanent equipment to facilitate maintenance)
- be securely fixed with a minimum clearance of 50mm between the top of the insulation and the underside of the walkway or platform to ensure a clear ventilation space.

Access may not be required where a void does not contain any permanent equipment, service connection boxes or connection points for TV aerials, etc where:

- the main roof consists of only a small void below the ridge where the raised collar is less than 2m in length
- roof cassette systems are used in forming room-in-roof and the length of the raised collar is over 2m and the floor to ceiling dimension below the ceiling is over 2.4m
- small voids are present in the eaves (including those which contain water pipes only).

Access hatches should be in accordance with Clause 7.2.15. Where an access hatch is required to provide fire resistance, the fire-resistance period should be supported by test evidence.

7.2.13 Dormer construction

Also see: Chapter 3.3

Dormers shall be adequately constructed. Issues to be taken into account include:

- 1) structure
- 2) ventilation
- 3) insulation
- 4) control of condensation
- 5) proprietary dormers.

7.2.13.1 Structure

Figure 37: Dormer — rafter supported

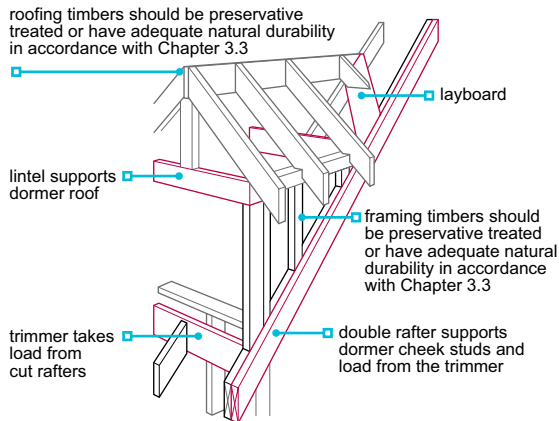
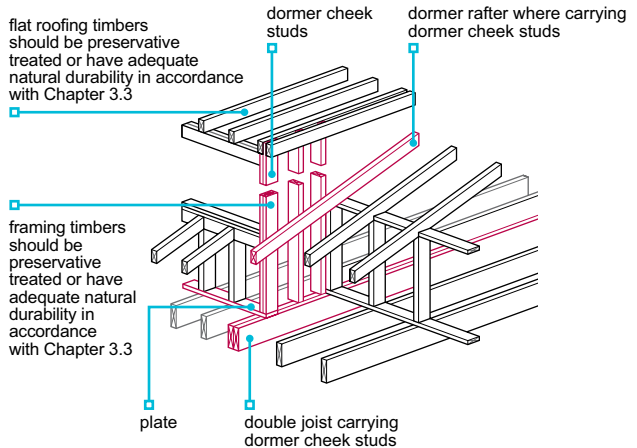

Figure 38: Dormer — floor supported



When constructing site formed dormer roofs:

- they should be constructed in accordance with the design
- cheek studs should be supported by either a double rafter or a double floor joist
- trimming members should be large enough to support additional loads from the main roof members, dormer framing and cladding
- a suitable lintel should be provided over the opening
- lintels should be structurally independent from the window frame
- trusses, where used, should be braced in accordance with this chapter
- timbers should be treated with preservative or have adequate natural durability in accordance with Table 1 of Chapter 3.3 Timber preservation (natural solid timber)
- the roof covering should comply with the requirements of this chapter or Chapter 7.1 Flat roofs, terraces and balconies
- unusually large or bespoke designs should have appropriate structural support designed by a suitably qualified person in accordance with Technical Requirement R5.

The external walls of a site formed dormer should:

- be sheathed and protected by a suitable breather membrane
- have a drained and ventilated cavity behind claddings, in accordance with Clause 6.2.10.

Lead, used to clad dormer cheeks, should be detailed in accordance with the Lead Sheet Training Academy 'Rolled Lead Sheet — The Complete Manual' and be:

- a minimum thickness of 1.80mm code blue (Code 4) or 2.24mm code red (Code 5) lead in a sheltered to moderate exposure zone or
- 2.24mm thickness code red (Code 5) or 2.65mm thickness code black (Code 6) lead in a severe exposure zone.

7.2.13.2 Ventilation

Pitched roofs shall be adequately ventilated to limit the risk of interstitial condensation. For cold roofs, ventilation should be provided from eaves to eaves or at ridge level, in accordance with Table 8.

Figure 39: Ventilation to dormer pitched roofs

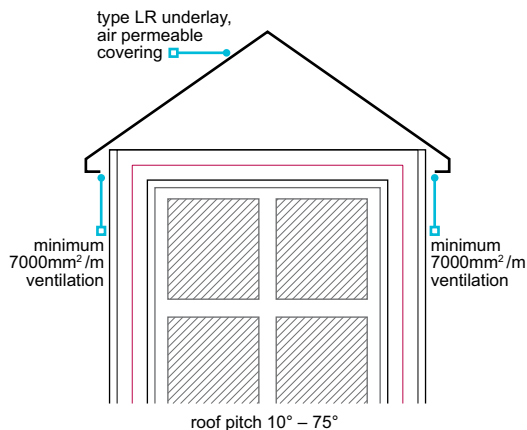

Figure 40: Room-in-roof (flat cold roof dormer)

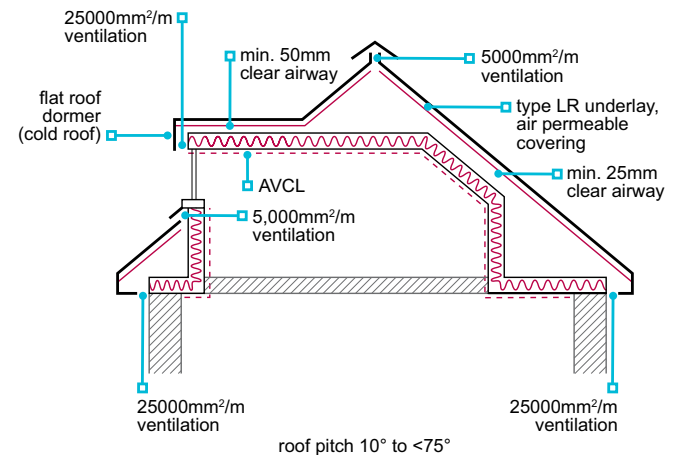

Table 8: Dormer pitched roof ventilation requirements

Cold roof with air permeable outer weatherproof covering			
Roof pitch	Underlay type	Ceiling type	Minimum eaves ventilation
10° to 15°	Type HR	Any	25,000mm ² /m
>15° and <75°	Type HR ⁽¹⁾	Any	10,000mm ² /m
10° to 75°	Type LR	Normal ⁽²⁾	7000mm ² /m
		Well-sealed ⁽²⁾	3000mm ² /m ⁽³⁾

Notes

1. High-level vent (5000mm²/m, based on the longest horizontal dimension) should be provided where the roof pitch exceeds 35°.
2. A normal ceiling typically has an air permeability of 300mm²/m² (0.3%). A well-sealed ceiling conforms to Clause 12.4.2 of BS 5250 and BS 9250, and typically has an air permeability of not more than 30mm²/m² (<0.03%).
3. Alternatively, a high-level vent 5000mm²/m based on the longest horizontal dimension of roof can be provided.

Where air impermeable outer weatherproof coverings are used, please refer to Clause 7.2.15 for guidance on roof ventilation strategies.

Flat roof dormers should:

- have falls to the front or sides
- be either of warm deck or cold deck construction (in accordance with BS 5250)
- be ventilated where of cold deck construction in accordance with Clause 7.1.11
- be constructed in accordance with Chapter 7.1 Flat roofs, terraces and balconies.

7.2.13.3 Insulation

Dormer roofs and cheeks should be insulated to meet the requirements of the Building Regulations.

7.2.13.4 Control of condensation

To limit interstitial condensation, site formed dormers should incorporate an AVCL to the walls.

AVCLs should also be provided to flat roofs, in accordance with Chapter 7.1, and are recommended to be applied to the warm side of the insulation within pitched roofs.

Further guidance on AVCLs can be found in Clause 7.2.15.

7.2.13.5 Proprietary dormers

Propriety dormers, eg glass reinforced plastic (GRP), should hold a satisfactory assessment by an appropriate independent technical approvals authority acceptable to NHBC.

Proprietary dormers should meet the Technical Requirements and:

- be suitably durable
- limit the risk of interstitial condensation occurring to the walls and roof
- be installed in accordance with certification requirements.

Walls and roofs of proprietary dormers should typically incorporate an AVCL. The AVCL specification should be in accordance with manufacturers' requirements.

7.2.14 Underlay, sarking boards and sheets

Underlay and sarking shall be provided to resist the passage of moisture.

Underlay and sarking should:

- be in accordance with the manufacturer's recommendations
- take account of the type and fixing of the roof covering
- be used in accordance with relevant assessments.

In areas of severe exposure, a rigid sarking sheet or board with underlay is recommended.

Table 9: Acceptable materials for use as underlay and sarking

Material	Standard/requirement	Minimum material specification (where applicable)	Minimum material thickness (where applicable)
Solid timber tongue and grooved or square edged board	BS 1297		16mm
Plywood	BS EN 636	BS EN 636 - 2S ⁽²⁾	9mm ⁽¹⁾
Chipboard	BS EN 312	Type P5	12mm ⁽¹⁾
OSB	BS EN 300	OSB/3	9mm ⁽¹⁾
Type HR (>0.25MN/g) and Type LR (<0.25MN/g) underlay	BS EN 13859-1	Class W1	
	BS 8747	1F/5U	
Type LR — low water vapour resistance (<0.25MN/g) and air permeable underlay (min. air permeability of 34m ³ /m ² .h at 50 Pa)	Technical Requirements R3 ⁽³⁾	Class W1	
Proprietary products	Technical Requirements R3 ⁽³⁾		

Notes

1. Minimum thickness suitable only where roof coverings (eg slates and tiles) are independently supported on battens, secured to counter battens. Minimum thicknesses quoted, actual design requirements may differ.
2. S = Structural.
3. Propriety products should hold a satisfactory assessment by an appropriate independent technical approvals authority acceptable to NHBC.

Underlay should:

- be provided to all tiled and slated roofs
- not be left exposed to sunlight for longer than recommended by the manufacturer
- where fully supported on a sarking sheet which offers a high resistance to the passage of air or water vapour, such as plywood, OSB, chipboard, or tongue and grooved sarking boards, be treated as a Type HR underlay for roof ventilation purposes
- be supported by a continuous fillet or proprietary eaves support tray, laid to inclined falls (see Figure 41), to prevent sagging (which can form a water trap)
- be securely fixed in accordance with manufacturers' requirements
- at vertical laps, be fixed only over rafters, and at horizontal laps be held in place by battens (where no batten is provided over a horizontal lap, the underlay manufacturers' guidance should be sought)
- be dressed into the gutter where exposed at eaves level, be UV resistant or of type 5U felt or a proprietary eaves guard used
- where traditional mortar pointing is used to bed ridge tiles, extend over the ridge, in accordance with Clause 7.2.19
- be detailed in accordance with manufacturers' requirements where proprietary ventilating ridge tiles or dry ridge systems are used
- continue over hips to form a 150mm minimum lap parallel with the hip rafter
- at abutments, be supported and turned up by a minimum of 100mm.

Underlays which are unsupported ie, not supported by sarking boards/sheets, should be laid with a drape between rafters or supports:

- to allow water to drain freely beneath tiling battens
- to ensure that water is deflected away from batten fixings.

Excessive drapes should be avoided to prevent transfer of loads to the outer roof covering and excessive noise nuisance under wind action.

Where no underlay drape is provided, counterbattens or proprietary spacers between the tiling battens and underlay should be installed, to ensure that there is a clear drainage path beneath the tiling battens, and a suitable sealing tape should be used to prevent water ingress via fixings.

Penetrations through the underlay should:

- be cut neatly to fit around service penetrations and not be torn ie, where pipes pass through the underlay
- follow manufacturers' fitting instructions where proprietary ventilation units and similar products are specified
- where no guidance is provided, be protected from water ingress using tapes or proprietary seals used in accordance with the manufacturer's instructions.

Table 10: Horizontal laps for unsupported and supported underlays

Pitch	Minimum horizontal laps	
	Unsupported underlay	Supported underlay
Less than 15°	225mm	150mm
15° and above	150mm	100mm

At valleys:

- the main roof underlay should be cut to the valley batten line
- a strip of underlay should be laid under the main roof underlay and held down by the valley battens (where used).

Figure 41: Underlay detailing

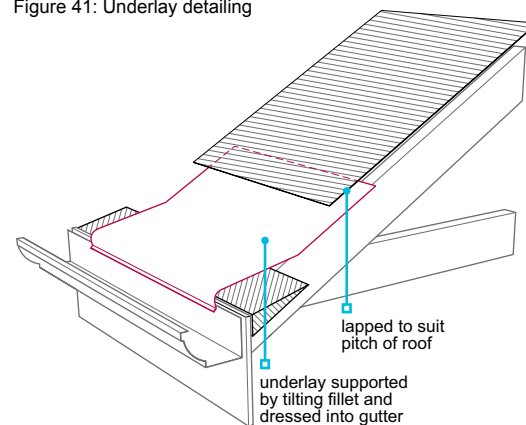

7.2.15 Ventilation, vapour control and insulation

Also see: BS 5250

Roofs shall have adequate precautions against condensation and cold. Issues to be taken into account include:

- 1) ventilation
- 2) vapour control
- 3) insulation
- 4) pipework.

7.2.15.1 Ventilation

This guidance on ventilation should be read in conjunction with the definitions table at the beginning of this chapter.

Pitched roofs should be adequately ventilated to limit the risk of interstitial condensation. Roof ventilation should be in accordance with BS 5250:2021 Management of moisture in Buildings — Code of practice.

The roof ventilation guidance in this clause is taken from BS 5250:2021 'Management of moisture in Buildings — Code of practice' for simple roof designs, where vents on opposite sides of the roof are likely to provide adequate ventilation. Where it is not possible to implement a ventilation strategy in accordance with BS 5250 due to the complexity of the roof design, specialist advice should be sought.

New-build homes can be at risk of a significant additional moisture load from the construction process and therefore roof-space condensation may occur during the first heating season. The builder may consider additional precautions than those stated below, to help reduce the potential for condensation during this period eg by providing 5,000mm²/m high-level ventilation in cold roof construction, where high-level ventilation is not required in the British Standard.

The roof ventilation strategy should be selected dependent upon:

- the roof covering ie, air permeable or air impermeable
- the underlay type ie, Type LR or Type HR
- the roof type ie, cold or warm roof
- the pitch of the roof
- the ceiling type ie, normal or well-sealed (where applicable).

Roofing underlay

Roofing underlays, Type HR or Type LR, should be selected with consideration for the roof type, the outer weatherproof covering and the design of the property, in order to ensure that the required ventilation provision can be met.

Where a Type LR underlay is fully supported on sarking sheets or boards which offer a high resistance to the passage of air or water vapour, such as plywood, OSB, chipboard, or tongue and grooved sarking boards, the Type LR underlay and sarking should be treated as a Type HR underlay, for roof ventilation purposes.

Where Type LR underlays are laid on open-jointed square edged sarking boards, typically 150mm wide with a minimum 2mm gap between each board, these may be treated as Type LR underlays, for roof ventilation purposes.

Air permeability of roof coverings

The manufacturer's information should be checked to confirm the air permeability of the roof covering. BS 5534 Slating and tiling for pitched roofs and vertical cladding. Code of practice (Annex L) provides information on testing the air permeability of tiles or slates.

Where the permeability of the roof covering is unknown, the roof covering should be treated as air impermeable.

Where arrays of integrated solar roof panels are installed forming the roof covering, the whole roof covering should be treated as air impermeable, unless the panel manufacturer is able to demonstrate that their system is air permeable. Integrated solar roof panel manufacturers may also require a larger air space beneath the panel than stated in this clause, to increase ventilation and cooling of the panel.

Roof ventilation strategies

Roof ventilation should:

- prevent the entry of birds, etc (fabrications with 3mm-10mm openings are acceptable)
- ensure that ventilation pathways remain clear ie, not blocked by insulation or the structure
- have a spacer in the eaves to allow insulation to be installed over and beyond the wall plate to minimise the thermal bridge without blocking the ventilation path (the spacer should be of sufficient length to maintain ventilation throughout the thickness of the insulation)
- incorporate correctly sized, proprietary eaves ventilators, which are fixed in accordance with the manufacturer's instructions.

Figure 42: Typical eaves ventilation

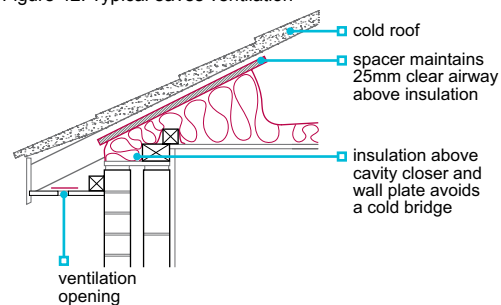

For the purposes of health and safety, it may not be necessary to provide ventilation to small roof areas (3m² or less) over porches or bay windows. Where no roof ventilation is proposed, a condensation risk analysis should be undertaken to ensure the risk of interstitial condensation is mitigated. Alternative designs for small roofs maybe more appropriate, for example:

- warm roof designs, or
- the use of air and vapour permeable underlays.

To avoid condensation in larger roofs, pitched roofs which incorporate insulation should be designed to limit the risk of interstitial condensation. Guidance on roof ventilation strategies can be found using the flow chart below:

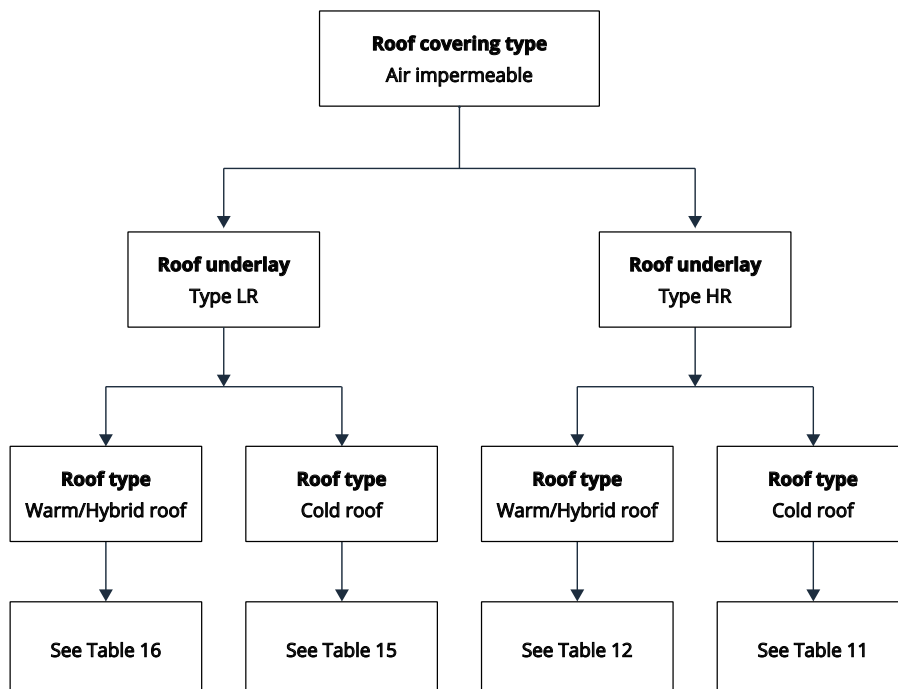
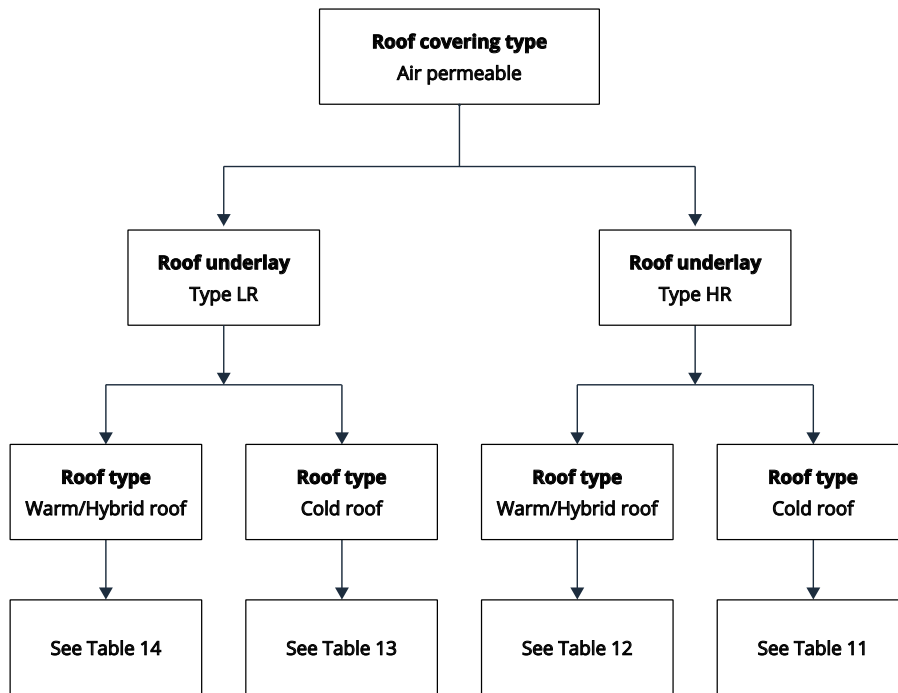

Air permeable outer weatherproof coverings

This section provides guidance on the roof ventilation strategy where an air permeable outer weatherproof covering is used.

Outer weatherproof coverings of concrete and clay tiles are typically classed as air permeable; manufacturers' information should be consulted.

Table 11: Cold roof ventilation (Type HR underlay⁽¹⁾ and air permeable⁽²⁾ outer roof covering)

Roof pitch	Minimum eaves/low-level ventilation (underneath underlay)	Additional requirements
10° to 15°	25,000mm ² /m ⁽³⁾	Additional 5,000mm ² /m ⁽³⁾ ridge or high-level ventilation (underneath underlay) should be provided where the roof pitch exceeds 35° or the roof span exceeds 10m, or the roof is a lean-to or mono pitched
>15° and <75°	10,000mm ² /m ⁽³⁾	

Notes

1. Where referred from Table 15, the ventilation strategy in Table 11 may also be applicable where no batten space ventilation is provided in a cold roof with an air impermeable outer roof covering. In this scenario a Type HR or Type LR underlay may be used.
2. The ventilation strategy in Table 11 is also applicable where an air impermeable outer roof covering is used.
3. Based on the longest horizontal dimension of the roof.

Figure 43: Roof pitch 10° to 15°

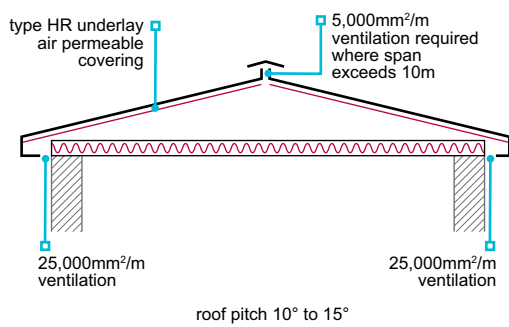

Figure 44: Roof pitch >15° and <75°

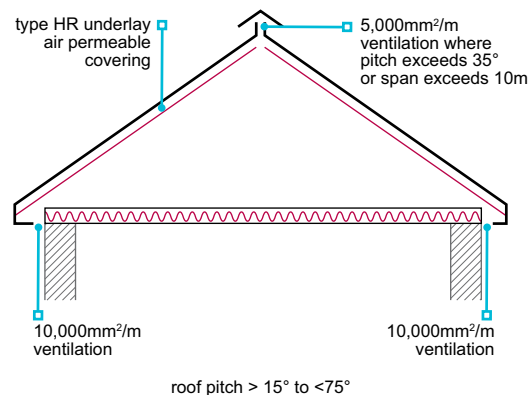

Figure 45: Mono pitched roof

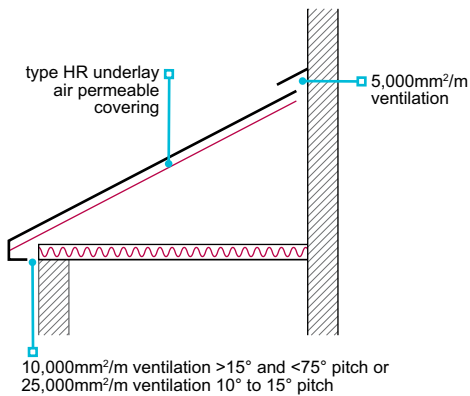

Table 12: Warm or hybrid roof ventilation (Type HR underlay⁽¹⁾ and air permeable⁽²⁾ outer roof covering)

Roof pitch	Minimum eaves/ low-level ventilation (underneath underlay)	Minimum ridge/ high-level ventilation (underneath underlay)	Additional requirements
10° to <75°	25,000mm ² /m	5,000mm ² /m	AVCL required Minimum 25mm clear ventilation pathway required ⁽³⁾

Notes

1. Where referred from Table 16, the ventilation strategy in Table 12 may also be applicable where no batten space ventilation is provided in a warm roof with an air impermeable outer roof covering. In this scenario Type HR or Type LR underlay may be used.
2. The ventilation strategy in Table 12 is also applicable where an air impermeable outer roof covering is used.
3. Minimum 25mm clear ventilation pathway is measured from the lowest point of the underlay drape or underside of sarking.

Figure 46: Hybrid roof — Room-in-roof

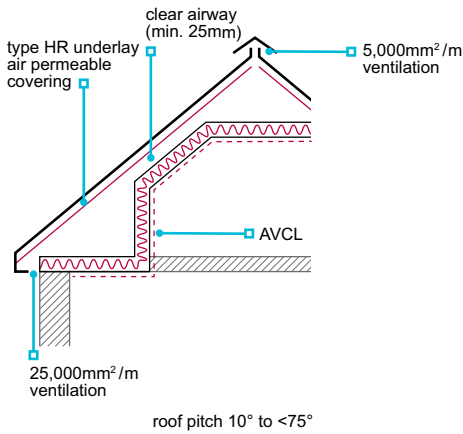

Figure 47: Hybrid roof — Room-in-roof (flat roof dormer)

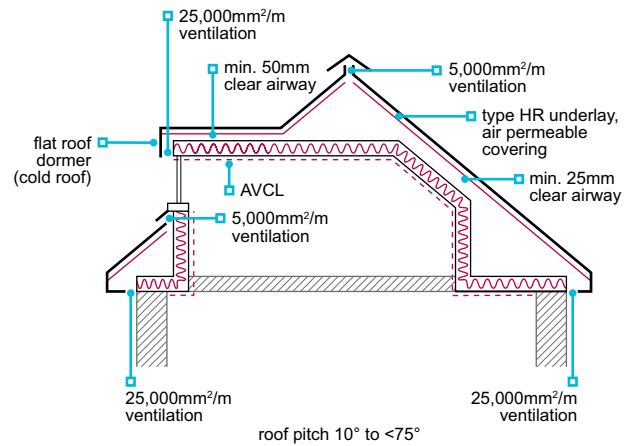

Figure 48: Warm roof

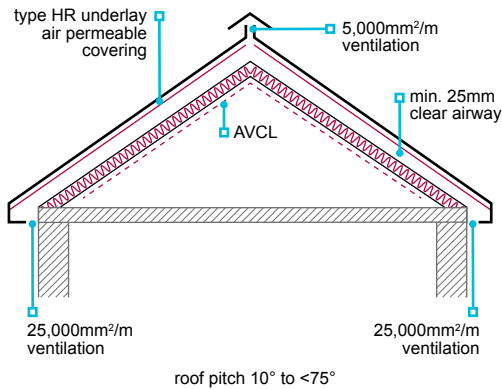

Table 13: Cold roof ventilation (Type LR underlay and air permeable outer roof covering)

Roof pitch	Ceiling type	Minimum eaves/low-level ventilation (underneath underlay)
10° to <75°	Normal ⁽¹⁾	7,000mm ² /m ⁽²⁾
10° to <75°	Well-sealed ⁽¹⁾	3,000mm ² /m ⁽²⁾⁽³⁾

Notes

1. A normal ceiling typically has an air permeability of 300mm²/m² (0.3%).
A well-sealed ceiling conforms to BS 9250 and typically has an air permeability of not more than 30mm²/m²(≤0.03%).
2. Based on the longest horizontal dimension of the roof.
3. Alternatively, a high-level vent 5,000mm²/m based on the longest horizontal dimension of roof can be provided.

Figure 49: Cold roof — Type LR underlay with air permeable covering

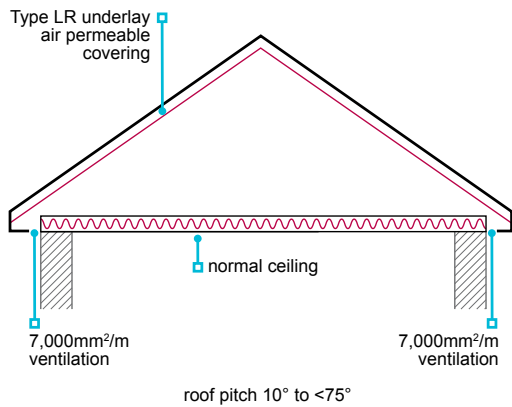

Where no ventilation is proposed to the cold roof void with air permeable outer roof coverings, the roofing underlay (Type LR) must be a low water vapour resistance and air permeable underlay and hold current certification for use in a non-ventilated application, from an appropriate independent technical approvals body acceptable to NHBC. Such membranes should have a water vapour resistance (s_p) not exceeding 0.05m (0.25 MN·s/g) and a minimum air permeability of 34m³/m².h at 50 Pa, or more.

Table 14: Warm or hybrid roof ventilation (Type LR underlay and air permeable outer roof covering)

Roof pitch	Roof type	Minimum eaves/ low-level ventilation (underneath underlay)	Minimum ridge/ high-level ventilation (underneath underlay)	Additional requirements
10° to <75°	Warm roof	None	None	AVCL required ⁽¹⁾ Underlay drape should be maintained
10° to <75°	Hybrid roof	7,000mm ² /m	5,000mm ² /m	AVCL required A minimum 25mm clear ventilation pathway is required ⁽²⁾

Notes

- Where a continuous AVCL is impractical to install, an additional 25,000mm²/m eaves or low-level ventilation and 5,000mm²/m ridge or high-level ventilation should be provided below the underlay. A minimum 25mm clear ventilation pathway is required below the underlay.
- Minimum 25mm clear ventilation pathway is measured from the lowest point of the underlay drape or underside of sarking.

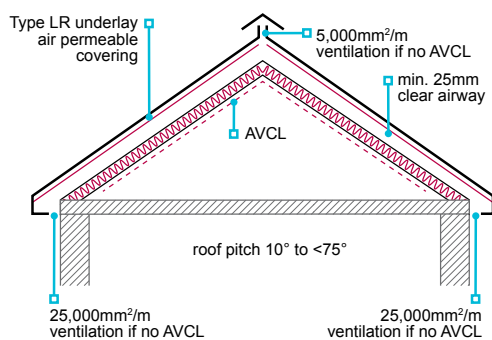
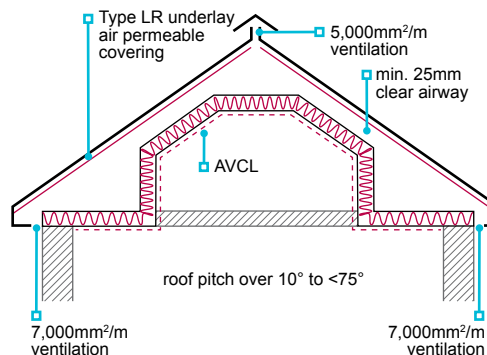
Figure 50: Warm roof — Type LR underlay with air permeable covering

Figure 51: Hybrid roof — Type LR underlay with air permeable covering

Cold roof with flat roof apex

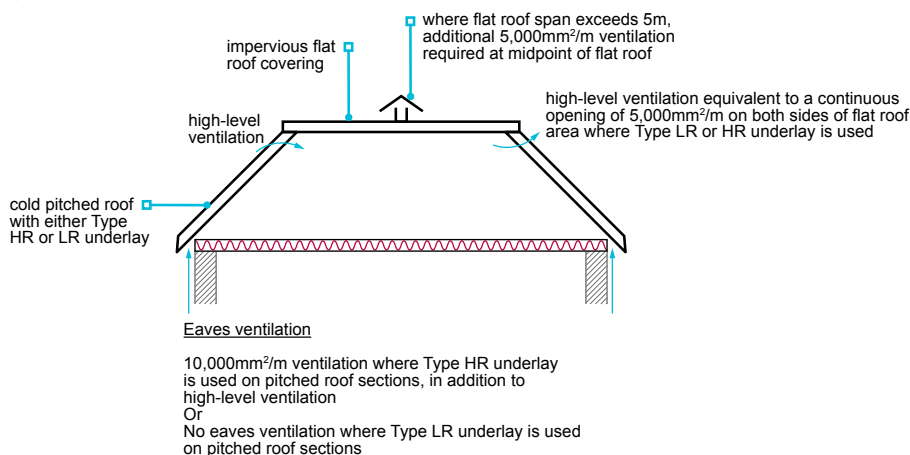
Where a cold pitched roof meets a cold flat roof, there is a risk of condensation occurring on the underside of the flat roof deck. Ventilation beneath the underlay should therefore be provided in accordance with Figure 52.

Figure 52: Cold pitched roof with flat roof apex

Air impermeable outer weatherproof covering

This section provides guidance on the roof ventilation strategy where an air impermeable outer weatherproof covering is used.

Outer weatherproof coverings of fibre cement slates, sheet metal, continuous bitumen or plastic membranes are typically considered to be air impermeable; manufacturers' information should be consulted.

Roofs with a Type HR underlay and air impermeable outer roof covering should be ventilated in accordance with the following guidance:

- cold roof — Table 11
- warm or hybrid roof — Table 12.

Roofs with a Type LR underlay and air impermeable outer roof covering should be ventilated in accordance with:

- cold roof — Table 15
- warm or hybrid roof — Table 16.

Table 15: Cold roof ventilation (Type LR underlay and air impermeable outer roof covering)

Roof pitch	Ceiling type	Minimum eaves/low-level ventilation (underneath underlay)	Minimum batten space ventilation using minimum 25mm deep counterbattens (above underlay) ⁽¹⁾
10° to <75°	Normal ⁽²⁾	7,000mm ² /m ⁽³⁾	25,000mm ² /m at eaves/low level and 5,000mm ² /m at ridge/high level
10° to <75°	Well-sealed ⁽²⁾	3,000mm ² /m (or 5,000mm ² /m ridge or high-level ventilation) ⁽³⁾	25,000mm ² /m at eaves/low level and 5,000mm ² /m at ridge/high level

Notes

1. If no batten space ventilation is provided, the Type LR underlay should be treated as a Type HR underlay and ventilation provided in accordance with Table 11 above.
2. A normal ceiling typically has an air permeability of 300mm²/m² (0.3%). A well-sealed ceiling conforms to BS 9250 and typically has an air permeability of not more than 30mm²/m² (≤0.03%).
3. Based on the longest horizontal dimension of the roof.

Figure 53: Cold roof — Type LR underlay with air impermeable covering

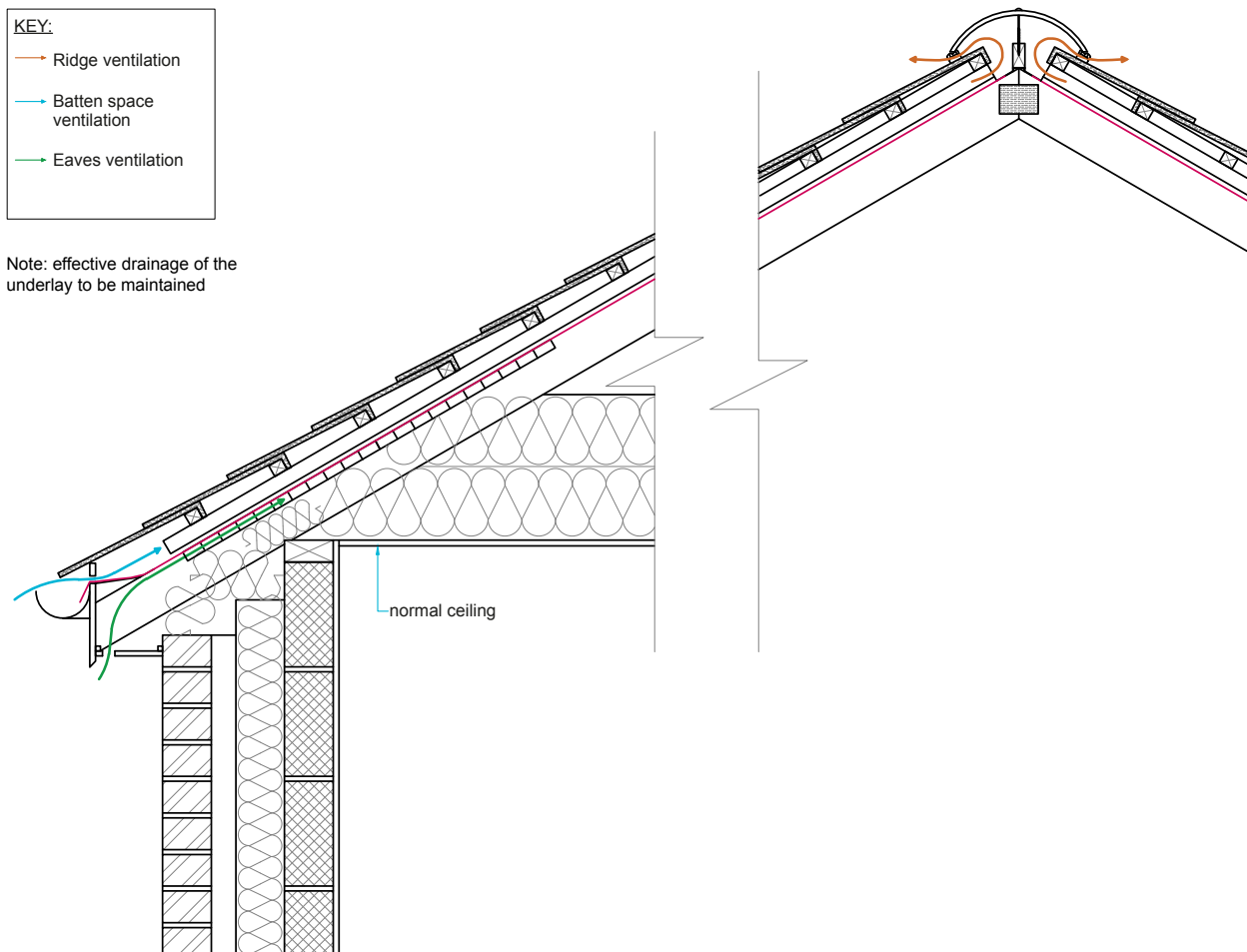
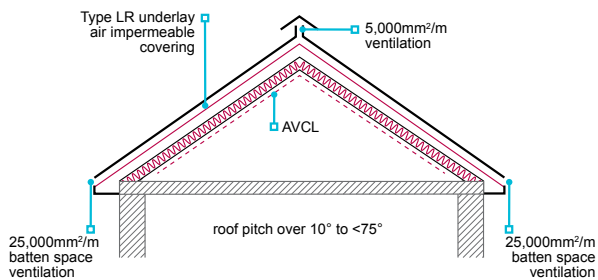
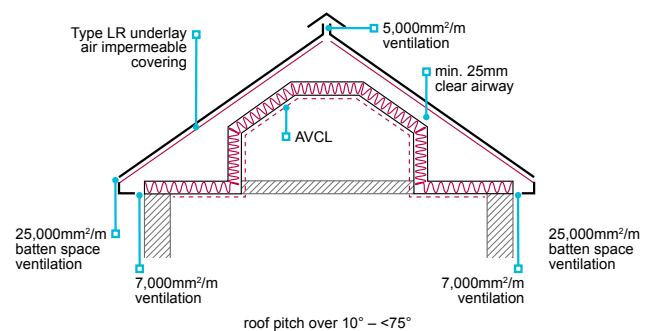

Table 16: Warm or hybrid roof ventilation (Type LR underlay and air impermeable outer roof covering)

Roof pitch and type	Minimum eaves/low-level ventilation (underneath underlay)	Minimum ridge/high-level ventilation (underneath underlay)	Minimum batten space ventilation using minimum 25mm deep counterbattens (above underlay)	Minimum ridge/high-level ventilation (above underlay)	Additional requirements
10° to <75° Warm roof	None	None	25,000mm ² /m at eaves or low level ⁽¹⁾	5,000mm ² /m	AVCL required Underlay drape should be maintained
10° to <75° Hybrid roof	7,000mm ² /m	5,000mm ² /m	25,000mm ² /m at eaves or low level	5,000mm ² /m	AVCL required A minimum 25mm clear ventilation pathway ⁽²⁾

Notes

1. If no batten space ventilation is provided then the Type LR underlay should be treated as a Type HR underlay and ventilation provided in accordance with Table 12 above.
2. Minimum 25mm clear ventilation pathway is measured from the lowest point of the underlay drape or underside of sarking.

Figure 54: Warm roof — Type LR underlay with air impermeable covering

Figure 55: Hybrid roof — Type LR underlay with air impermeable covering

Pitched roofs with no ventilation provision and air impermeable outer weatherproof covering

Pitched roofs with no ventilation provision and air impermeable outer weatherproof covering will not be acceptable to NHBC.

7.2.15.2 Vapour control

AVCLs should be provided in accordance with the design and be:

- placed on the warm side of insulation
- used in warm and hybrid roof construction.

AVCLs should be:

- installed once framing timbers have a moisture content of less than 20%
- installed once the building is weathertight
- selected in accordance with the design, eg a minimum 500 gauge (125 micron) polyethylene sheet, vapour control plasterboard or a product assessed in accordance with Technical Requirement R3
- fixed at 250mm centres to framing members, including laps and around openings; boards should be fitted in accordance with Chapter 9.2 Wall and ceiling finishes
- lapped into openings ie, roof windows, dormers, etc
- sealed around service penetrations, where used, downlighters should be specified and sealed to limit air leakage
- made good where damage has occurred.

Joints in the AVCLs:

- should have 100mm minimum laps
- should be located on rafters
- may be sealed with adhesive tape for enhanced airtightness (but joints should still occur over rafters).

Where vapour control plasterboard is used, joints should be:

- positioned on rafters
- cut with care to avoid displacing the vapour control material
- filled, taped and finished, in accordance with the design and manufacturers' recommendations.

Where the ceiling below a cold pitched roof includes an AVCL, the design should ensure adequate ventilation is provided to the habitable areas to prevent condensation problems in the home.

Access hatches to cold roof voids should have:

- an air leakage rate not more than 1m³/h at a pressure of 2 Pa when tested to BS EN 13141-1, or
- a push-up cover with a minimum weight of 5.5kg and compress a closed cell seal or 'O-ring' between the cover and frame (clamps may also be required to ensure that the cover compresses the seal).

Figure 56: Ceiling penetrations

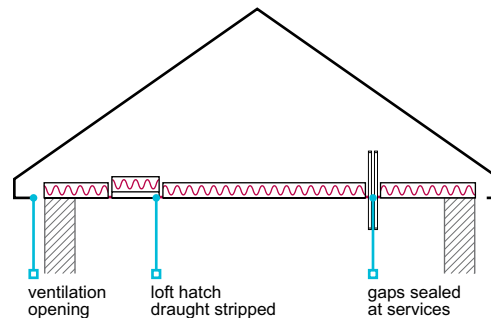

Proprietary hatches should be fitted and sealed to the surrounding construction in accordance with the manufacturer's instructions.

7.2.15.3 Insulation

Insulation should be of sufficient thickness to meet the requirements of Building Regulations and laid over the whole loft and wall plate.

The thermal performance of any access hatch should contribute to the overall thermal performance of the ceiling or wall in which the hatch is located and avoid cold bridging.

Table 17: Suitable materials for roof insulation

Material	Standard
Mineral wool	BS EN 13162
Blown mineral fibre	BS 5803-2
Blown cellulose fibre	BS 5803-3
Rigid polyurethane foam	BS EN 13165
Proprietary products	Technical Requirement R3 ⁽¹⁾

Note

1. Proprietary products should hold a satisfactory assessment by an appropriate independent technical approvals authority acceptable to NHBC.

7.2.15.4 Pipework

To reduce the risk of freezing or condensation forming on pipework in roof voids, the following precautions should be taken:

- where possible, water pipes should be below the main roof insulation
- water pipes should be insulated in accordance with Clause 8.6.3
- roof insulation should be placed above and around water tanks, but not below them
- 'cold rising' pipework above ceiling level should be insulated, even where it is below the main roof insulation.

Figure 57: Storage tank insulation

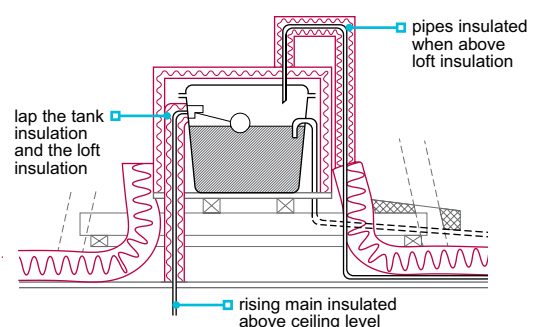

7.2.16 Fire-stopping and cavity barriers

Also see: Chapter 6.8

Pitched roofs shall be constructed to provide adequate fire resistance and separation.

Fire-stopping should be provided in accordance with the Building Regulations, including at the junction between a compartment wall and roof, and be extended into any eaves.

When providing fire-stopping:

- gaps between compartments should be fire-stopped, using materials which achieve the same level of fire resistance as the compartment wall
- compartment walls should stop approximately 25mm below the top of adjacent roof framing, and a soft fire-stopping material should be used to allow for movement in roof timbers and prevent 'hogging' of the tiles.

Cavity barriers should be provided in accordance with the Building Regulations, including at the edges and junctions of cavities.

When providing cavity barriers, they should be:

- sized appropriately for the cavity
- tightly fitted to a rigid construction
- mechanically fixed in position.

Combustible material, such as roof timbers and sarking felt, should be kept away from heat sources.

Figure 58: Fire precautions

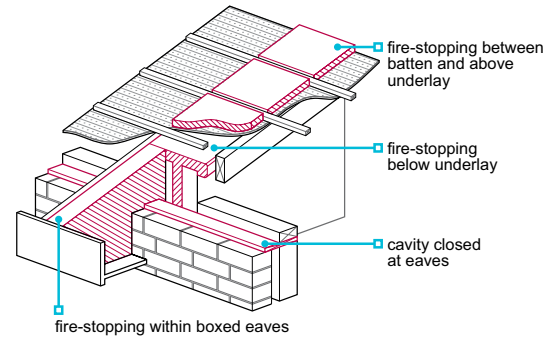

7.2.17 Battens

Also see: Chapter 3.3 and Part 8.0

Battens and counter battens shall be adequately sized, spaced and fixed to support the roof covering.

Battens and counter battens should be:

- in accordance with BS 5534, accompanied by a delivery note and indelibly marked with the supplier, origin, grade and size
- preservative treated and not re-sawn, ripped or planed after treatment (battens can be cut to length)
- where cut ends are located in wet or dry verges, treated with preservative
- cut square, butt jointed over rafters and nailed to each rafter they span
- fixed by skew driven nails on each side of a joint.

Counter battens should be fixed to the rafters and not only to sarking sheets or boards. The dimensions of counter battens should be sufficient to provide a ventilation gap (where required) and permit a drainage pathway beneath the battens.

Battens should be:

- a minimum of 1.2m long and span a minimum of three rafters
- set out in straight lines parallel to the ridge and to the gauge required for the tile or slate (the lap should not be decreased as this would reduce weathertightness)
- set out so that the tiles project a minimum of 50mm over the gutter
- fixed through counter battens to rafters
- where on sarking sheets or boards, be supported on counter battens
- installed to finish 25mm-50mm from the outer edge of the verge undercloak, or in accordance with the manufacturer's instructions where proprietary dry verge systems are used
- sized in accordance with the roof covering/solar roof panel manufacturer's recommendations, but not less than shown in Table 18.

Table 18: Minimum batten sizes

		450mm span		600mm span	
		Depth	Width	Depth	Width
Double-lap slates	Natural: sized or random	25mm	50mm	25mm	50mm
	Fibre cement or concrete	25mm	38mm	25mm	50mm
Clay/concrete tiles	Double-lap	25mm	38mm	25mm	38mm
	Single-lap	25mm	38mm	25mm	50mm

Notes

1. Tolerances on the basic sizes of timber battens should be: width ± 3 mm, depth $-0 + 3$ mm.
2. Batten sizes may need to be increased, where solar roof panels are installed, to ensure full fixing depth penetration is achieved.

Battens should be set out to avoid joints occurring over the same rafter. Where batten spacing is:

- more than 200mm, no more than one batten in any group of four should be joined over any one truss or rafter, see Figure 60
- 200mm or less, no more than three joints should be made over any 12 consecutive battens, see Figure 61.

Figure 60: Correct batten jointing — batten gauge >200mm

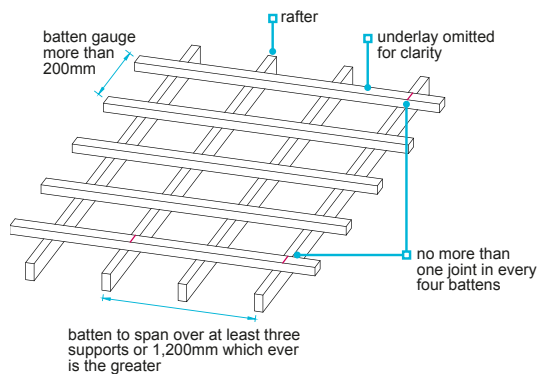

Figure 59: Incorrect batten jointing

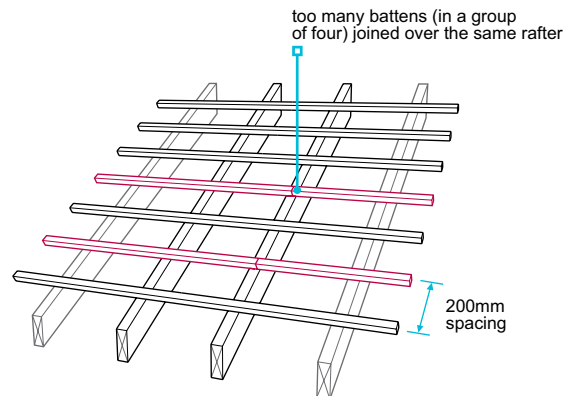
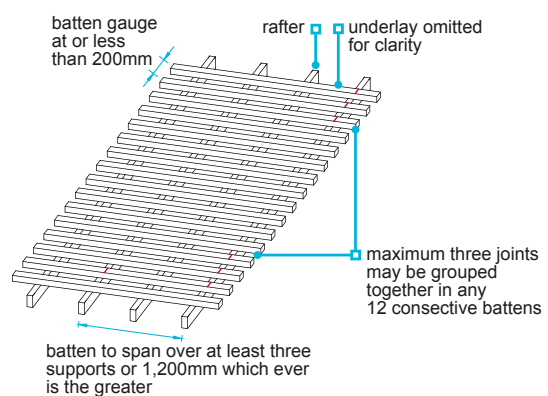

Figure 61: Correct batten jointing — batten gauge ≤200mm



Batten fixings should be capable of resisting wind forces in accordance with BS 5534 (Annex H.7 Batten fixing penetration). The length, type and material specification of the fixing to be used should be determined according to the site exposure and location.

Nails for fixing battens and counterbattens should meet the following minimum requirements:

- a driven nail of a minimum of 3.35mm diameter with 40mm minimum penetration into the supporting structure
- a mechanical gun nail with a shank diameter not less than 3.1mm
- round plain shank, indented, spiral roll or annular ring shank nails may be selected (ring shank nails are recommended in Scotland and Northern Ireland)
- zinc-coated in accordance with BS EN 10230-1
- hot dip galvanised steel or aluminium when situated in a coastal location.

Nails should not be driven below the top of the batten, as this reduces the thickness of timber between the nail head and the underside of the batten, which reduces the pull-off resistance and may damage the batten.

7.2.18 Roof coverings

Also see: Part 8.0

Roof coverings shall be of a suitable quality and durability to protect the building from weather.

When covering a pitched roof:

- coverings should be in accordance with the design and established building practices
- recovered materials may be used where prior approval by NHBC has been granted (independent certification of suitability may be required).

Table 19: Standards relevant to roof coverings

Material	Standard	Code of practice	Other guidance
Clay tiles and fittings	BS EN 1304		
Concrete tiles and fittings	BS EN 490 and BS EN 491		
Dry fixed systems	BS 8612		
Natural slates	BS EN 12326		
Fibre cement slates and fittings	BS EN 492		
Fully supported lead sheet roofing		BS 6915	Technical Requirement R3
Rolled lead sheet for building purposes	BS EN 12588		
Zinc and zinc alloys	BS EN 988	CP 143-5	Technical Requirement R3
Copper	BS EN 1172	CP 143-12	Technical Requirement R3
Stainless steel	BS EN 508-3		Technical Requirement R3
Aluminium	BS EN 508-2	CP 143-15	Technical Requirement R3
Roof windows	BS EN 14351-1		Technical Requirement R3
Natural stone slates			Established practices
Thatch			Standards set by the Thatching Advisory Services or other appropriate authority, in accordance with Technical Requirement R3
Shingles should be of Western red cedar			Grade 1 to the Canadian Standards Association
Proprietary roof coverings and products ie, Pre-formed chimneys, GRP and composite products (dormers, copings, cappings, bay window canopies, etc)			Proprietary products should hold a satisfactory assessment by an appropriate independent technical approvals authority acceptable to NHBC

Natural slates used for roofing should meet the requirements of Table 20.

Table 20: Acceptable characteristics for natural slates

Characteristics	Grade to BS EN 12326:2014 ⁽¹⁾
Water absorption less than 0.6%	W1
Thermal cycle	T1
Carbonate content less than 20%	S1

Note

- A copy of the slate manufacturers' Accompanying Commercial Document (ACD), in accordance with BS EN 12326:2014, should be provided to NHBC when requested.

7.2.19 Fixing tiles and slates

Also see: BS 5534

Coverings shall be suitably fixed to protect the building from weather. Issues to be taken into account include:

- | | |
|-------------------------------|-------------------------------|
| 1) eaves, ridge and hip tiles | 3) mortar |
| 2) verges | 4) mansard roofs and dormers. |

Careful setting out will improve the finished appearance of the roof, help avoid problems such as unequal overhangs, and reduce excessive tile cutting at abutments, chimneys and similar obstructions.

When installing coverings:

- clay tiles that do not meet the dimensional and geometric requirements given in BS EN 1304 should not be laid at pitches less than 40°
- joints between tiles and slates should be slightly open, which provides some flexibility in setting out and should help to avoid tile cutting (single-lap interlocking tiles have a tolerance of approximately 3mm at the joint)
- tile-and-a-half or double tiles should be used, where available from the manufacturer, to avoid the use of small sections of cut tile which are difficult to fix
- small sections of cut tile (where unavoidable) should be bonded to the adjacent full tile in accordance with the manufacturer's instructions
- the bottom edges of double-lap slate and plain tile roofs should be finished with an under-eaves course.

Table 21: Pitch, gauge and lap

Type or tile	Gauge	Minimum head-lap	Minimum permissible pitch (°)
Plain (double-lap)	Maximum 1/3 length lap	65mm generally for clay tiles 75mm in severe exposure conditions	35 (clay) 35 (plain concrete)
Concrete (single-lap interlocking)	Comply with the manufacturer's recommendations	75mm or to the manufacturer's recommendations	30 ⁽²⁾
Slates (double-lap)	Maximum 1/3 length lap	54mm ⁽¹⁾ minimum, increased with lower pitch and severe exposure conditions	20 subject to head-lap

Notes

1. For pitches greater than 45° and less than 75° in sheltered and moderate exposure zones only.
2. For pitches below 30°, evidence shall be provided as to suitable performance.

When fixing coverings to a pitched roof:

- the fixing schedule should be produced by the tile manufacturer; fixings for single and double-lap tiles should be in accordance with BS 5534 and BS EN 1994-1-4 (evidence of calculations in compliance with Technical Requirements R3 and R5 may be required)
- coverings should be fixed in accordance with the design and manufacturers' recommendations
- perimeter (see definitions) roof tiles or slates should be mechanically fixed using a minimum of two fixings (subject to meeting the wind loading recommendations), one of which can be a tile clip, adhesive (following manufacturers' recommendations) or dry verge capping system where designed to resist uplift
- slates and tiles should generally be fixed using clout or slate nails (these should be either silicon bronze, phosphor bronze, aluminium to BS 1202-3 or copper to BS 1202-2) additionally, tiles can be fixed using stainless steel clout nails
- galvanised steel nails should not be used for slates and tiles
- fixings should be a minimum of 38mm long, and penetrate a minimum of 15mm into battens
- tile clips should be made of aluminium alloy or other alloy types, stainless steel, non-ferrous metals or polymer-based materials, and be of adequate durability and strength in accordance with BS 5534
- slates should be fixed in accordance with BS 5534, fully nailed over the whole roof, and nailed twice where centre nailed; alternatively, slate hooks maybe used where they can be shown to resist wind uplift.

Where slate hooks are used, they should:

- meet the requirements of BS 5534
- have a minimum shank diameter of 2.7mm
- be stainless steel grade 316 to BS EN 10088-3
- be 'nail-in' type slate hooks and not 'hook-over' batten type
- have a crimped shank when used on roof pitches less than 30 degrees (slate hooks should not be used on roof pitches below 25 degrees).

Where the hooked fixing method is used, slates at the perimeters of a roof, eg eaves, valleys, verges, ridges, hips, abutments and penetrations, should be nailed (or nailed and hooked) to resist uplift and lateral drift.

7.2.19.1 Eaves, ridge and hip tiles

At eaves:

- tiles should project a minimum of 50mm across the gutter
- when using natural or fibre cement slates or plain tiles, an under-eaves course should be used
- the height of the fascia should maintain the tile pitch, in accordance with the tile manufacturer's recommendations.

Where ridge tiles are mortar bedded:

- on duo pitched roofs, the underlay should be lapped over the ridge in accordance with Table 10
- on mono pitched roofs, the underlay should extend over the mono ridge by a minimum 100mm
- small openings above the top batten are permitted at ridges where required for ventilation of the roof void.

At hips:

- underlay should continue to form a 150mm minimum lap parallel with the hip rafter
- where wet bedded tiles are used, they should be supported at the base by a galvanised hip iron and project to the centre line of the gutter.

Ridge and hip tiles should be mechanically fixed with self-sealing non-ferrous fixings into timber battens, and have a nominal joint thickness of 10mm where wet bedded.

Wet bedded 'baby' hip/ridge tiles to low-level roofs, such as those over porches and ground floor bay windows, may be bedded using mortar only, subject to self-weight being sufficient to resist the wind loads, in accordance with BS 5534 (Annex H). Where no wind uplift calculation is provided, baby hip/ridge tiles should be mechanically fixed, in accordance with manufacturers' recommendations.

Where proprietary dry fixed ridge and hip systems are used, they should conform to BS 8612 and be installed in accordance with manufacturers' requirements.

Figure 62: Eaves detailing

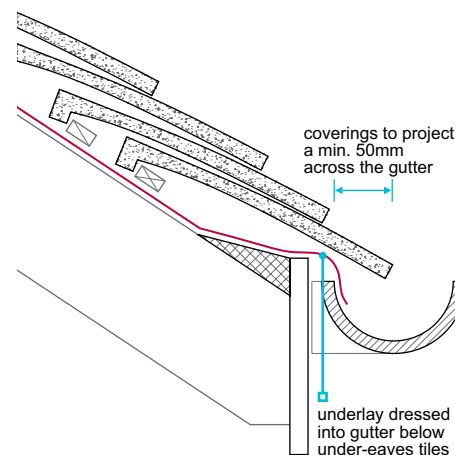

Figure 63: Mechanically fixed ridge

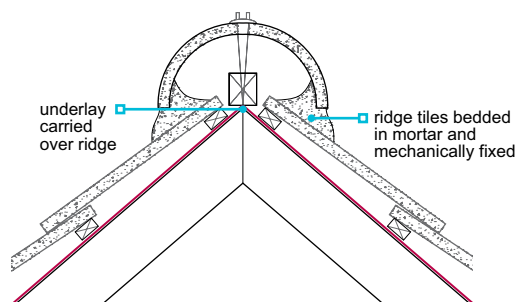
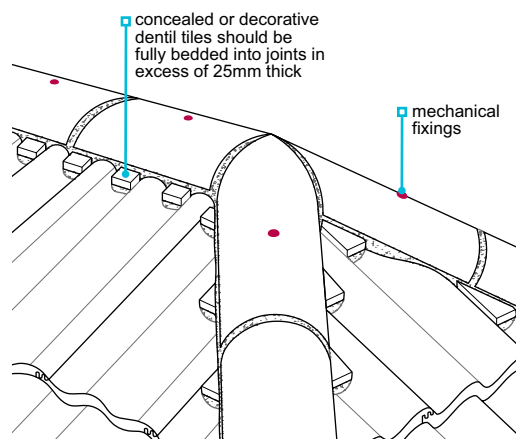

Figure 64: Wet bedded ridge with dentil tiles



7.2.19.2 Verges

Where proprietary dry verge systems are used, they should conform to BS 8612 and be installed in accordance with manufacturers' requirements.

Unless a proprietary dry verge system or cloaked verge is used, tiles should be bedded into a 100mm-wide bed of mortar on an undercloak of fibre cement board, plain tile or slate. Undercloaks should be a minimum of 150mm wide and laid face down. Plain tiles should not be used as an undercloak below 30° pitch or on a bargeboard.

Undercloaks should be:

- fixed in accordance with manufacturers' recommendations
- installed to a true line
- installed at the correct level to ensure that the line of the tiling is maintained where it passes over the wall, and not tilted inwards
- bedded on roofing mortar and struck off flush with the external surface of the wall (alternatively, a suitable exterior grade bedding sealant should be used in accordance with manufacturers' recommendations)
- securely nailed to a true line where a bargeboard is used.

Figure 65: Wet verge

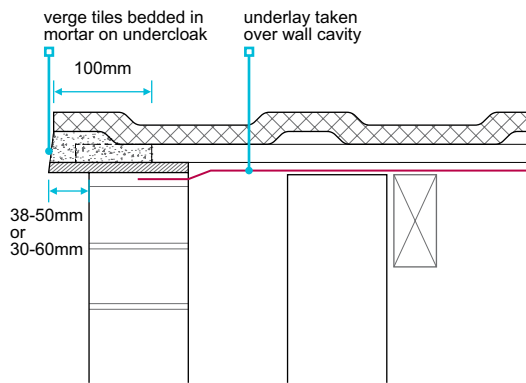
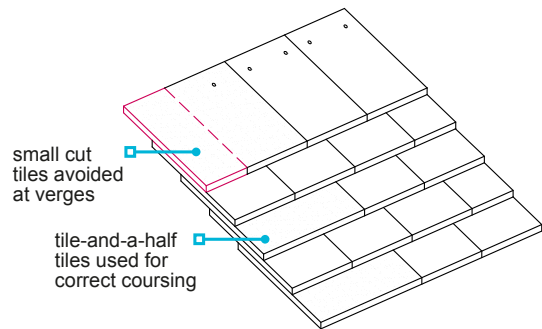

Figure 66: Verge — plain tiles



Where verge tiles and slates are wet bedded, pointing should be completed as soon as possible using the same mix.

Verge clips should be in full contact with the tile to resist uplift, nailed twice to battens and sized to ensure that they are in direct contact with the top surface of the verge tile.

Where plain tiles and slates are used at the verge:

- they should project 38-50mm beyond the gable wall or bargeboard
- cut plain tiles are not acceptable, and purpose-made plain tile-and-a-half tiles should be used, see Figure 66

- natural slate verges should be formed with full slates and either slate-and-a-half or half slates that are a minimum of 150mm wide.

Where interlocking tiles are used at the verge:

- they should project 30-60mm beyond the gable wall or bargeboard

- small sections (less than a half tile width) of cut interlocking tiles should be avoided; where cut tiles (less than half a tile width) are used, these should be bonded to the adjacent tile in accordance with manufacturers' recommendations.

7.2.19.3 Mortar

When bedding tiles or slates in mortar:

- the mortar should be 1:3 cement:sand with plasticiser
- the mortar should be a mix based on sharp sand with soft sand added to achieve workability; the proportion of sharp sand should not be less than one third of the total sand content (proprietary mixes may be accepted by NHBC where they are shown to have similar strength, durability and workability)

- pointing should be completed as soon as possible using the same mix
- tiles should be wetted on their contact surface, and surface water allowed to drain away before fixing
- concealed or decorative dentil tiles should be fully bedded into joints in excess of 25mm thick.

7.2.19.4 Mansard roofs and dormers

When fixing tiling and slating to mansard roofs (75° or steeper) and dormers:

- all tiles and slates should be fixed in accordance with the manufacturer's requirements and BS 5534
- tiles and slates should be fully nailed; single-lap tiles require additional tail clips, double-lap tiles (nibbed) require two nails, fibre cement slates require additional disc rivets and slates should be centre nailed
- all tiling and slating should be laid over battens and counter battens, secured to the sheathing board in line with vertical supports
- batten and counter batten sizes should be in accordance with this chapter
- a suitable breather membrane/underlay should be provided in accordance with BS 5534
- the length of the top course should ensure that the minimum head-lap is maintained

- the eaves course should be supported by a tilting fillet or other proprietary product which substantially maintains the same plane as the main cladding
- at internal or external angles, purpose-made corner tiles or soakers should be used to form weathertight joints
- where pitched roofs abut a dormer, abutments should be formed in accordance with Clause 7.2.20 and BS 5534
- at dormer cheeks, the tiles or slates should be specified to be cut close to the slope of the roof
- where air impermeable outer weatherproof coverings, eg fibre cement slates, are used, ventilation behind the weatherproof covering should be in accordance with the manufacturer's requirements.

Vertical tiling and slating to walls should conform to Chapter 6.9 Curtain walling and cladding.

7.2.20 Weathering details

Also see: Chapter 6.8

Weatherproofing shall be provided at abutments, flat roof intersections, changes in slopes and projections to resist the passage of moisture to the inside of the building. Issues to be taken into account include:

- | | |
|---|---------------------------------|
| 1) abutments | 3) projections through the roof |
| 2) flat roof intersection or changes in slope | 4) raking copings. |

Flashing details should be appropriate for the roof and the type of roof covering used, in accordance with BS 5534. Where flashings come into contact with metal, they should be formed using non-ferrous material.

Table 22: Suitable materials for weathering details

Material	Standard	Additional information
Rolled lead sheet ⁽²⁾	BS EN 12588	<ul style="list-style-type: none"> Aprons, cover flashings⁽¹⁾ and saddles⁽¹⁾ should be minimum thickness 1.80mm code blue (Code 4) lead Soakers should be minimum thickness 1.32mm code green (Code 3) lead
Aluminium and aluminium alloys	BS EN 485 and BS EN 573	0.7 - 0.9 mm thick and protected on both sides by a coating of bituminous paint where built into brick, stone or concrete
Zinc alloys	BS EN 988	Minimum of 0.8 mm thick
Copper	BS EN 1172	Flashings, soakers and saddles should be: <ul style="list-style-type: none"> fully annealed 0.55mm thick (0.7 mm thick for inclined valleys)
Proprietary products eg lead replacement products, GRP flashings, etc	Technical Requirement R3	Propriety products should hold a satisfactory assessment by an appropriate independent technical approvals authority acceptable to NHBC

Notes

- Lead thickness may need to increase in line with the severity of exposure. Thicknesses quoted are for sheltered to moderate exposure zones.
- Where lead flashings are turned into joints by more than 50mm, they will require bitumen paint protection on both sides.

7.2.20.1 Abutments

Where a flat or pitched roof over an enclosed area abuts a wall, or a balcony abuts a wall, cavity trays should be linked to the flashing to prevent water penetrating into an enclosed area. Horizontal flashings should provide weathering to a minimum of 75mm above the intersection with the roof.

At abutments:

- flashings, soakers and gutters should be provided as necessary
- lead flashings should have a minimum upstand of 75mm and minimum lap of 100mm
- flashings should be tucked 25mm into a bed joint and wedged in place at not more than 450mm centres, or a minimum of one per step for stepped flashings
- joints between the masonry and flashing should be pointed with cement mortar or suitable exterior grade sealant in accordance with the manufacturer's recommendations.

Where a pitched roof abuts the wall at an angle:

- a preformed stepped cavity tray linked to a stepped flashing should be used
- stepped flashings should be cut from a strip a minimum of 150mm wide
- stepped flashings should be a minimum of 65mm wide.

Figure 67: Wall abutment

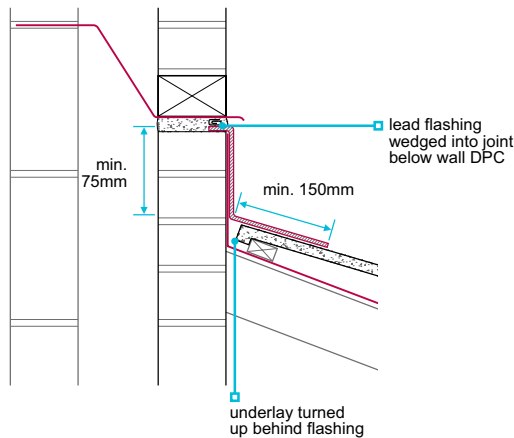
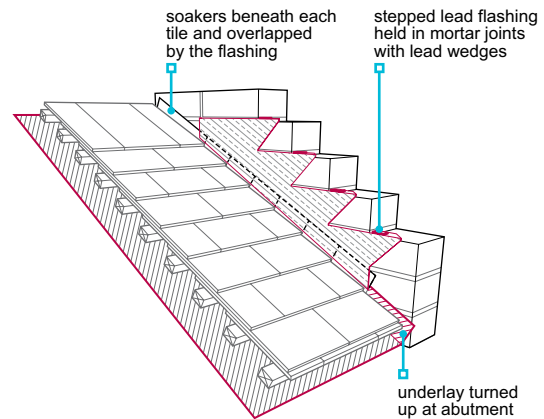

Figure 68: Side abutment (double-lap clay or concrete plain tile and slate)



Roof side abutment details should be correctly formed, dependent upon the chosen tile or slate.

When using double lap clay and concrete plain tiles, side abutments should be formed:

- using soakers and step flashings, or
- an abutment gutter, including a single step flashing, detailed in accordance with the manufacturer's recommendations (where there is a risk of blockage by debris, a step and cover flashing should be provided).

When using single lap clay and concrete interlocking tiles, side abutments should be formed:

- for profiled tiles, a flashing detail conforming to the tile manufacturer's recommendations or an abutment gutter including a single step flashing, detailed in accordance with the manufacturer's recommendations (where there is a risk of blockage by debris, a step and cover flashing should be provided)
- for flat or substantially flat tiles, an abutment gutter including a single step flashing, detailed in accordance with the manufacturer's recommendations (where there is a risk of blockage by debris, a step and cover flashing should be provided).

When using natural or artificial slates, side abutments should be formed:

- using soakers and step flashings, or
- an abutment gutter including single step flashing, detailed in accordance with the manufacturer's recommendations (where there is a risk of blockage by debris, a step and cover flashing should be provided).

Figure 69: Side abutment gutter

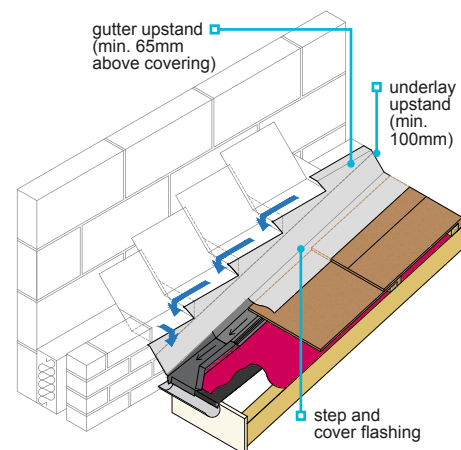

Where abutment gutters are constructed using sheet metal, they should be detailed in accordance with the relevant sheet metal technical recommendations.

7.2.20.2 Flat roof intersection or changes in slope

Where there is a change in the slope, or an intersection with a flat roof and:

- the change is 5° or more (eg at mansards and sprockets), flashings or soakers should be used
- a ridge meets the main roof, a saddle flashing should be used.

Where a flat roof adjoins a pitched roof:

- the waterproof membrane should be carried up under the tiling to a height of 150mm above the flat roof, and lapped by the roofing underlay
- the lowest course of tiles or slates should not touch the roof membrane.

Figure 70: Dry valley — lead saddle

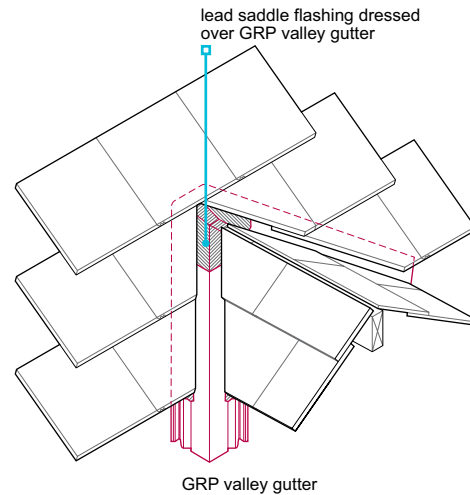
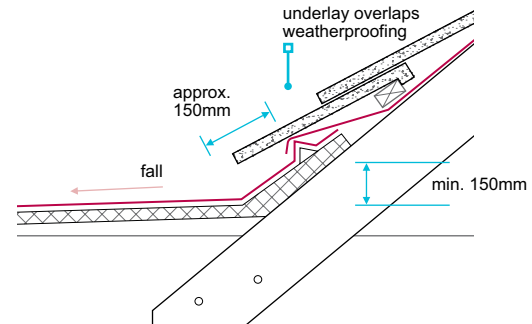

Figure 71: Flat roof adjoining a pitched roof



7.2.20.3 Projections through the roof

Where there is a projection through the roof:

- components should be installed according to the manufacturer's recommendations
- flashings should be provided (eg at chimneys)

- where pipes penetrate tiling, a weathertight joint should be formed using a lead slate flashing and upstand or a purpose-made one-piece accessory; where lead slates are used they should be supported (eg using exterior grade plywood) to prevent sagging.

Figure 72: Chimney — back gutter

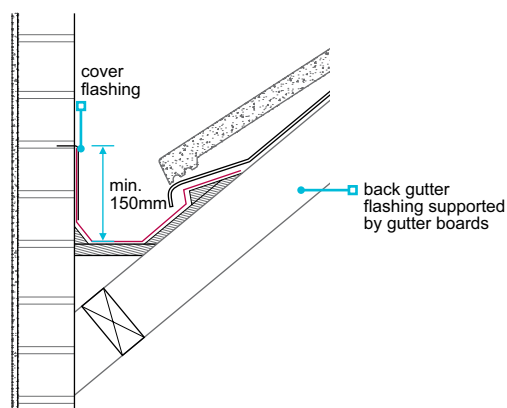
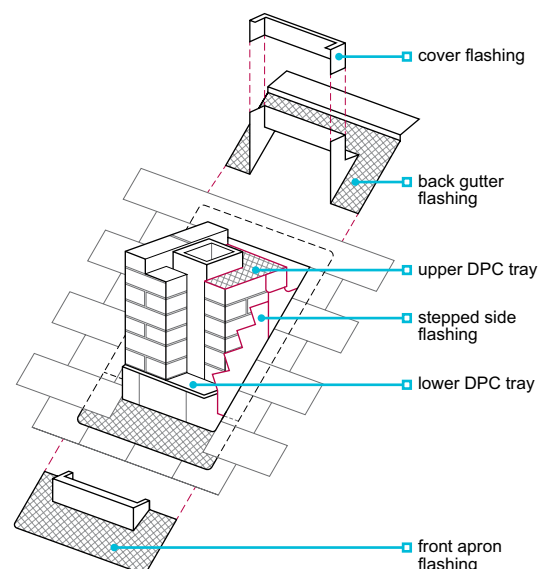

Figure 73: Chimney penetration



7.2.20.4 Raking copings

Copings, including those manufactured from natural stone, reconstituted stone and GRP, should be securely fixed to gable walls using suitably durable fixings, and be weathertight.

To resist wind uplift and gravitational forces, L-shaped brackets should be used to secure each stone coping to the head of the wall.

The brackets should:

- have dowel bars that fit into restraint holes in the copings
- be adequately durable and manufactured from stainless steel (such as grade 304/316 to BS EN 10088-2)
- be fixed to a solid piece of masonry, with fixings of a suitable length, gauge and durability.

DPCs should prevent the downward passage of moisture and be installed under the coping to ensure that the wall is weathertight. The DPC should:

- be bitumen-based material to BS 6398, BS EN 14967 or other material assessed in accordance with Technical Requirement R3
- extend the full width of the wall
- be fully bedded in mortar
- be supported over the cavity.

Fixing methods that penetrate the DPC should be designed to ensure weathertightness. This can be achieved by extending the lower DPC under the bracket and installing the next section of the DPC over it to create a lap that covers the fixing point.

Copings should have an overhang with throatings a minimum of 30mm clear of the wall, 40mm where the wall is rendered.

Figure 74: Raking coping — masonry

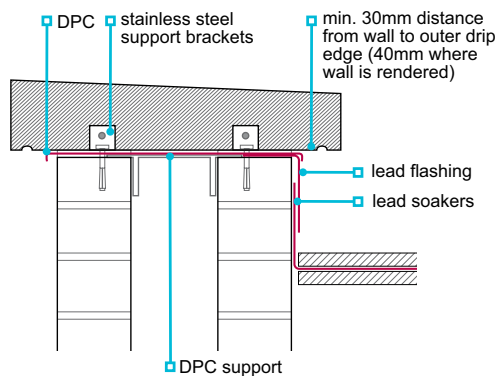
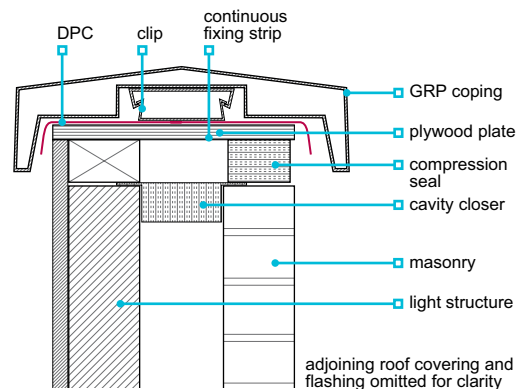

Figure 75: Raking coping — framed structure



Where GRP copings are used, they should:

- be fixed in accordance with the manufacturer's instructions
- include a DPC beneath
- be sealed using an appropriate sealant
- allow for normal differential movement in the timber or LSF structure
- hold a satisfactory assessment from an appropriate independent technical approvals authority acceptable to NHBC.

Further guidance can be found in Chapter 6.2 External timber framed walls and Chapter 6.10 Light steel framing.

7.2.21 Valleys and hidden gutters

Valleys shall have suitable weathering details, including flashings, to resist the passage of moisture to the inside of the building.

Valleys, and the components used, should:

- be in accordance with the design and BS 5534
- have a finished pitch which complies with the minimum recommended for the roof
- be fixed in accordance with the manufacturer's recommendations
- have a suitable saddle flashing (see Figure 70) or appropriately detailed lead flashing (minimum thickness 1.80mm code blue) at the head of each valley
- be formed using valley coursing tiles (plain tiles), valley trough tiles (interlocking tiles), non-ferrous metal or proprietary products which hold a satisfactory assessment from an appropriate independent technical approvals authority acceptable to NHBC.

Tiles either side of a valley should:

- be cut from double tiles, tile-and-a-half or half tiles where available from the manufacturer
- where small pieces (less than half tile width) of cut single-lap tiles are used, these should be bonded to the adjoining full width tile, in accordance with the manufacturer's recommendations.

Where the roof covering is slate or plain tiles, the following may be used:

- a laced valley
- a swept valley
- a mitred valley with soakers.

Horizontal valley gutters, where positioned over a compartment wall, should achieve the roof classification as required by the Building Regulations ie, B_{ROOF}(t4) and be appropriately fire-stopped.

Valleys using valley tiles

Where valleys are formed using valley tiles:

- purpose-made valley coursing tiles should be used where the roof uses plain tiles
- purpose-made valley trough tiles should be supported by gutter boards where the roof uses single-lap interlocking tiles
- they should be mechanically cut to the correct rake
- adjacent coverings should be neatly cut to form a smooth junction, and preferably be cut from tile-and-a-half tiles
- they should have a minimum 100mm wide channel (minimum 125mm for pitches below 30°)
- they should be fixed in accordance with the manufacturer's recommendations.

Lead-lined valleys

For lead-lined valleys, the tiles should be cut and bedded on mortar over an undercloak (to prevent direct contact between the lead and the mortar). Mortar should not bridge the welt detail.

Lead should be:

- either minimum thickness 1.80mm code blue (Code 4) or 2.24mm code red (Code 5)
- supported on gutter boards of a minimum 19mm exterior grade plywood to BS EN 636-3, or as specified in the design
- laid in strips no longer than 1.5m
- lapped by a minimum of 150mm, where pitches are above 30°
- used in accordance with the Lead Sheet Training Academy The Complete Manual.

Proprietary valley or gutter systems

Proprietary valley systems should:

- be used in accordance with the manufacturer's recommendations and securely fixed to suitable supports (exterior grade materials should be used)
- be assessed in accordance with Technical Requirement R3.

Proprietary gutter systems should:

- be used in accordance with the manufacturer's recommendations and securely fixed to suitable supports (exterior grade materials should be used)
- be assessed in accordance with Technical Requirement R3.

7.2.22 Drainage

Roof drainage shall adequately carry rainwater to a suitable outlet.

Drainage should be:

- provided where roofs are greater than 6m²; however, consideration should be given to providing drainage to smaller roofs such as dormer, porch roofs and balconies (see Clause 7.1.4)
- of a sufficient size to accommodate normal rainfall, and sized to cope with concentrated flows ie, where there are dormer roofs
- designed and fitted to prevent erosion of the lower surface, where water from a large roof surface discharges onto another surface
- fixed in accordance with the design, using the correct type of fittings for internal and external angles, outlets, etc to ensure efficient drainage of the roof
- supported and jointed in accordance with the manufacturer's recommendations
- insulated when passing through a home, in accordance with Part 8.0 Internal services and low or zero carbon technologies
- installed ensuring gutters are provided with stop ends, and are laid with a sufficient fall towards the outlet, unless designed to be flat.

The discharge of rainwater in gutters and pipes from one roof to another should be avoided, where practicable. Small quantities of rainwater discharge, from one roof to another, are acceptable, if the total quantity discharged does not exceed the normal drainage characteristics of the roof below.

Where gutters are behind parapet walls, an overflow should be provided and be:

- sized for effective flow rate and positioned to prevent water from entering the building
- of higher capacity than the combined capacity of the other outlets
- positioned to discharge safely away from the building
- visible when in operation.

Where a downpipe discharges above ground level, or above a drainage gully, the downpipe should be fitted with shoes.

7.2.23 Fascias and trim

Also see: Chapter 3.3

Fascias, bargeboards and soffits shall be appropriately fixed and treated against decay.

Table 23: Materials acceptable for fascia boards

Material	Standard	Minimum material specification	Additional information
Marine grade plywood	BS 1088	Standard grade	Coated
Exterior grade plywood	BS EN 636	Bond class 3	Preservative treated and coated
Natural solid timber boards	N/A	Timber should be preservative treated or naturally durable	See Table 1 in Chapter 3.3 Timber preservation (natural solid timber)
High-density fibre reinforced calcium silicate board	BS EN 12467	Category A	
Glass fibre reinforced cement (GRC) board			
Proprietary products	Technical Requirement R3		

When installing fascia boards and soffits:

- timber for external feature work should be free from waney edges, large knots, resinous pockets, splits and other unsightly defects
- where preservative treated timber is cut, preservative should be applied to the cut end
- where timber is to be painted, it should be knotted and primed on all surfaces before fixing
- where timber requires a stained finish, one coat of stain should be applied before fixing
- each joint should be cut and fixed neatly.

Fascia boards should be fixed:

- twice to each rafter
- with splayed butt joints.

7.2.24 Spandrel panels in cold roofs

Spandrel panels shall provide satisfactory performance.

Spandrel panels used in cold roof voids to create separation between dwellings or to form the inner leaf of gable walls should be designed, manufactured and installed to provide satisfactory performance. Issues to be taken into account include:

- fire resistance
- acoustic transfer
- structural stability.

Spandrel panels that comply with guidance from the Structural Timber Association or the Trussed Rafter Association will generally be acceptable to NHBC.

7.2.25 Roof cassette systems

Also see: Chapter 3.3

Roof cassette systems shall form the roof structure and habitable space beneath and safely transmit loads to the supporting structure without undue movement or deformation. Issues to be taken into account include:

- | | |
|-------------------------------------|---------------------------------|
| 1) provision of information | 5) condensation and ventilation |
| 2) structural performance | 6) moisture protection |
| 3) thermal and acoustic performance | 7) durability |
| 4) fire | 8) installation. |

Roof cassette systems are building systems consisting of prefabricated roof panels which may also be supplied with prefabricated wall panels, beams and other supporting structure. Systems can be open or closed panel.

7.2.25.1 Provision of information

Clear and fully detailed drawings should be available on site to enable work to be carried out in accordance with the design. Design and specification information should be issued to site supervisors, relevant specialist subcontractors and other appropriate personnel, and include the following information:

- a full set of drawings
- material specifications
- fixing schedules
- junction details, eg steps and staggers in both the horizontal and vertical plane
- the position and material specification for cavity barriers and fire-stopping
- manufacturers' requirements relating to ancillary items, eg chimneys, dormers, etc
- site installation manual.

7.2.25.2 Structural performance

The structure of the roof cassette system should be adequately designed to support dead, imposed and wind loads in accordance with the requirements of Clause 7.2.3.

Compound deflection of the roof cassette system should be designed to acceptable limits, particularly where they are supported by roof purlins.

7.2.25.3 Thermal and acoustic performance

The roof and walls of roof cassette systems shall be insulated in accordance with the Building Regulations and shall be constructed to ensure that sound transmission is adequately limited between homes, in accordance with the Building Regulations.

7.2.25.4 Fire

The roof cassette system should meet the fire performance requirements of the Building Regulations, including all critical junctions, eg where walls and roof cassettes intersect.

The roof cassette system should:

- have adequate structural fire protection
- provide adequate compartmentation between dwellings
- have cavity barriers and fire-stopping in accordance with the Building Regulations.

7.2.25.5 Condensation and ventilation

The elements of the roof cassette system shall adequately limit the risk of interstitial condensation and be constructed in accordance with BS 5250. AVCLs should be provided in accordance with the manufacturer's recommendations.

Rooms formed by the roof cassette system shall be adequately ventilated in accordance with the Building Regulations.

7.2.25.6 Moisture protection

Walls and roofs should be adequately protected from moisture, using appropriate breather membranes and roofing underlays.

Wall and roof membranes shall form a continuous barrier to moisture and be adequately lapped.

Roof coverings should be in accordance with this chapter.

Wall cladding should be in accordance with the relevant NHBC chapter(s).

7.2.25.7 Durability

The structure of the system shall have a life expectancy of at least 60 years. Timber members should be preservative treated or have adequate natural durability in accordance with Chapter 3.3 Timber preservation (natural solid timber).

7.2.25.8 Installation

The system shall be erected in accordance with the manufacturer's recommendations and provide satisfactory performance. Issues to be taken into account include:

- competence of installers
- preparation
- design tolerances
- structural connections
- sealing of joints.

The manufacturer should provide and make available on site a set of clear instructions in the form of a site installation manual and relevant accompanying drawings, detailing the assembly and installation for the system as appropriate.

Systems should be installed by operatives who:

- are competent
- are familiar with the system being installed
- hold a certificate (or similar confirmation) confirming that they have been trained by the system manufacturer.

Ancillary components

Ancillary components ie, dormers, chimneys and roof windows, should be capable of integrating with the roof cassette system to ensure structural integrity and weathertightness is maintained.

7.2.26 Solar roof panels

Also see: Part 8.0

Solar roof panels should be securely fixed and not adversely affect the weather resistance of the building. Where the solar roof panels form the roof covering, they should be of suitable quality and durability to protect the building from weather. Issues to be taken into account include:

- 1) weathertightness
- 2) fixing
- 3) ventilation and vapour control
- 4) durability.

7.2.26.1 Weathertightness

Integrated solar roof panels should meet the weathertightness criteria in Part 8.0 Internal services and low or zero carbon technologies.

The installer should consult the tile or slate manufacturer prior to installing solar roof panels, to ensure compatibility with the tile or slate and weathertightness.

Connections may need to penetrate through the outer weatherproofing layer, which may potentially affect the roof covering, underlay and insulation of a roof. All penetrations should be carefully detailed, and appropriate flashings, etc used in accordance with the manufacturers' recommendations, to ensure the weathertightness of the penetration.

Mounting brackets which pass through the tiling or slating should not affect:

- the weathertightness of the tiles or slates
- the stability of the tiles or slates.

Proprietary flashing kits should be used around integrated solar roof panels. Flashing kits should ensure the weathertightness of the array and be installed to avoid excess gapping, sagging or kicking of the tiles or slates, and be fixed in accordance with the manufacturer's recommendations.

7.2.26.2 Fixing

Where solar roof panels are installed to the roof, these may be either:

- 'on-roof' type and sit above the roof covering, or
- integrated into the tile or slate array, to also form the roof covering.

Solar roof panels may be secured:

- to the roof framing
- to both the roof framing and roofing battens.
- to roofing battens, or

Solar roof panels should be secured in accordance with manufacturers' requirements and be capable of resisting wind uplift and snow loads for the building and its specific location (see also Part 8 Services).

Roofing battens should be adequately fixed where used to secure solar roof panels. Batten fixings should be capable of resisting wind forces in accordance with BS 5534 (Annex H.7 Batten fixing penetration), see also Clause 7.2.17.

7.2.26.3 Ventilation and vapour control

Where arrays of integrated solar panels are installed, the outer roof covering should be treated as air impermeable and the whole roof ventilated accordingly unless the panel manufacturer is able to demonstrate their system is air permeable. Guidance on roof ventilation strategies can be found in Clause 7.2.15.

Solar roof panel manufacturers may also require a ventilated air space beneath the panel, to increase ventilation and cooling of the panel.

7.2.26.4 Durability

Solar roof panels and associated brackets, fixings, flashings and trims should be adequately durable and suitable for their location.

Appropriate materials should be selected for flashings. Guidance can be found in Clause 7.2.20.

In aggressive environments such as coastal locations, grade 316 stainless steel fixings are recommended.

7.2.27 Further information

- *BM TRADA Eurocode 5 Span Tables 4th Edition for solid timber members in floors, ceilings and roofs for dwellings*
- *BS 8103-3 Structural design of low-rise buildings — Code of practice for timber floors and roofs for housing*
- *Trussed Rafter Association Technical Handbook*
- *BS EN 1995-1-1 Eurocode 5: Design of timber structures — General. Common rules and rules for buildings*
- *PD 6693-1 Recommendations for the design of timber structures to Eurocode 5: Design of timber structures — General. Common rules and rules for buildings*
- *BS 5250 Management of moisture in buildings. Code of practice*
- *BS 5534 Slating and tiling for pitched roofs and vertical cladding. Code of practice*



Part 8

Internal services and low or
zero carbon technologies

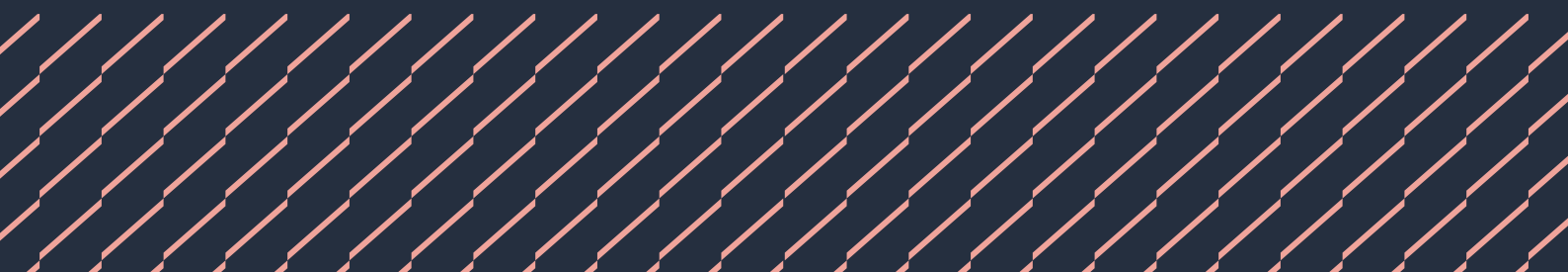

Internal services

This chapter gives guidance on meeting the Technical Requirements for internal services, including:

- the supply of hot and cold water services
- vented and unvented hot water storage systems
- plumbing
- gas services
- electrical installations.

8.1.1	Compliance	02
8.1.2	Provision of information	02
8.1.3	Water services and supply	02
8.1.4	Cold water storage	05
8.1.5	Gas services	06
8.1.6	Electrical services	07
8.1.7	Meter boxes	12
8.1.8	Hot water services	12
8.1.9	Unvented storage systems	14
8.1.10	Internal soil and waste systems	16
8.1.11	Further information	18



Figure reference table

Figure Reference Table 8.1

Fig No	Title/Description	Clause	Page
Figure 1	Protection from the cold — loft space	8.1.3.4	4
Figure 2	Protection from the cold — header tanks	8.1.3.4	4
Figure 3	Pipe insulation thickness	8.1.3.4	4
Figure 4	Underfloor water supply pipe insulation	8.1.3.4	4
Figure 5	Masonry brick and block plastered	8.1.5.1	6
Figure 6	Dry lined walls on batons	8.1.5.1	6
Figure 7	Dry lined walls on dabs	8.1.5.1	6
Figure 8	Timber frame or light steel construction wall	8.1.5.1	6
Figure 9	Installed in a timber frame or light steel construction wall	8.1.5.1	6
Figure 10	Safe location of cables	8.1.6.3	8
Figure 11	Notice examples	8.1.6.4	9
Figure 12	Horizontal distance of electrical items to sinks	8.1.6.4	10
Figure 13	Horizontal distance of electrical items to hobs	8.1.6.7	10
Figure 14	Cavity tray with inset meter box	8.1.7.2	12
Figure 15	Weephole position with inset meter box	8.1.7.2	12
Figure 16	Low level unvented discharge — trapped gully	8.1.9.3	15
Figure 17	Low level unvented discharge — path or garden area	8.1.9.3	15
Figure 18	Unvented discharge — soil stack	8.1.9.5	16
Figure 19	Air admittance valves	8.1.10.2	17
Figure 20	Sound insulation to soil and vent pipe	8.1.10.3	17

Definitions for this chapter

Mixing (Table 8)	Relates to the cooling effect when incoming cold water mixes with the hot water storage volume, cooling the tank contents, reducing performance and wasting energy.
Stratification (Table 8)	Relates to the tank volume not being cooled by the introduction of cold water when running the hot volume off.
Thermostatic mixing valve (TMV)	A valve that allows the 60°C water leaving the storage cylinder to be blended with cold mains water to achieve the designed temperature.
Wholesome water	Fit to use for drinking, cooking, food preparation or washing without any potential danger to human health.

8.1.1 Compliance

Also see: Chapter 2.1

Incoming utilities shall comply with the Technical Requirements and take account of service entries, ground hazards and chemical attack.

Internal services which comply with the guidance in this chapter will generally be acceptable.

Adequate precautions against ground hazards and the entry of gas ie, radon or gas, from landfill sites should be provided as necessary. Further guidance can be found in BRE Report 211 Radon: Guidance on protective measures for new dwellings (including supplementary advice for extensions, conversions and refurbishment projects) and BRE Report 212 Construction of new buildings on gas-contaminated land. Also see Chapter 4.1 Land quality — managing ground conditions.

8.1.2 Provision of information

Designs and specifications shall be produced in a clearly understandable format, include all relevant information and be distributed to the appropriate personnel.

Provision of information is important as it allows for energy-efficient use of the building and common methods adopted to prevent overheating.

Clear and fully detailed drawings should be available on site to enable work to be carried out in accordance with the design. Design and specification information should be issued to site supervisors, relevant specialist subcontractors and suppliers, and where used include the following information:

Common information required for all of Part 8:

- fixing schedule
- a full set of current drawings
- indication of which manufacturer and/or installer is responsible for each system and interface
- commissioning schedule
- manufacturers' specifications
- interface details
- on-site testing requirements
- type and spacing of clips and fixings
- type and location of ancillary components, including those used for fire safety and acoustic purposes
- commissioning certificates
- cold water pipe runs
- water efficiency calculations.

8.1.3 Water services and supply

Water services shall be based on the pressures and flow rates supplied from the incoming main. Components shall be selected and installed to ensure satisfactory service for the life of the system, with suitable precautions taken against corrosion and damage. Issues to be taken into account include:

- 1) suitability of materials and components
- 2) adequate supply
- 3) durability
- 4) protection from the cold
- 5) wholesome water
- 6) water efficiency.

8.1.3.1 Suitability of materials and components

Relevant standards for materials and components used in domestic water systems include:

BS EN 806	Specifications for installations inside buildings conveying water for human consumption
BS EN 12897	Water supply. Specification for indirectly heated unvented (closed) storage water heaters
BS EN 1057	Copper and copper alloys. Seamless, round copper tubes for water and gas in sanitary and heating applications
BS 1566	Copper indirect cylinders for domestic purposes
BS 3198	Specification for copper hot water storage combination units for domestic purposes
BS 7291	Thermoplastics pipe and fitting systems for hot and cold water for domestic purposes and heating installations in buildings
BS 8558	Guide to the design, installation, testing and maintenance of services supplying water for domestic use within buildings and their curtilages. Complementary guidance to BS EN 806

8.1.3.2 Adequate supply

The design and installation of the water services supply should:

- be in accordance with Building Regulations, statutory requirements and the recommendations of the water supplier
- ensure drinking water is provided at the kitchen sink direct from the supply pipe or, where this is impracticable, from a storage cistern containing an adequate supply of drinking water
- be based on a minimum 1.5 bar dynamic pressure at the stop valve inside the home
- ensure a minimum of 20L/min flow rate is available at the stop valve inside the home
- account for pressure and flow rate reductions (a wider supply pipe may be required inside the home)
- account for pressure fluctuations and surges, which may occur within the system and potentially damage fittings (surge arresters may be required)
- ensure that stop valves within the curtilage and outside the home are protected by a shaft or box
- ensure that service pipes are a minimum of 750mm below the ground surface — where this is not possible, adequate precautions should be taken against frost and mechanical damage
- ensure that underground ducts are sealed at both ends to prevent the entry of fluids, vermin and insects
- be of materials which are safe and minimise the risk of corrosion
- be in accordance with the recommendations of the water supplier, including compatibility of the supply with the materials and fittings
- ensure that the water system is capable of being drained (hot and cold services separately).

8.1.3.3 Durability

The hot and cold water service should be installed using corrosion-resistant pipes and fittings.

In areas where pitting corrosion of copper cylinders occurs, it may be necessary to fit aluminium protector rods. These should be fitted during manufacture in accordance with the relevant British Standard. Sacrificial anodes should be installed where required by the water supplier.

8.1.3.4 Protection from the cold

Also see: Clause 7.2.15

To reduce the risk of freezing, or condensation forming on the pipework, water services should be located in the warm envelope of the home. Where possible, water pipes should be below the main roof insulation.

Particular care is needed with cisterns, vent pipes, bends and junctions, especially near openings to the outside air, such as eaves.

Where they are located in unheated spaces, they should be insulated and not affected by cold. Insulation should be provided:

- around water services, including pipework (in accordance with Tables 1 and 2)
- as specified in the design (but not beneath a cold water tank)
- on each side of raised tanks in unheated roof spaces
- even where it is below the main roof insulation (see Figure 1, 2 and 3)
- in accordance with BS EN 806 and BS 8558.

Figure 1: Protection from the cold — loft space

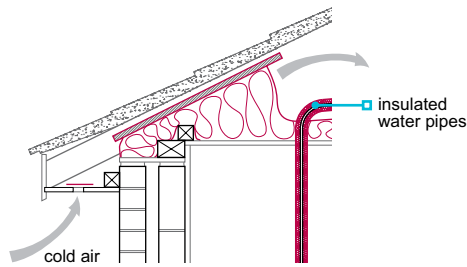

Figure 2: Protection from the cold — header tanks

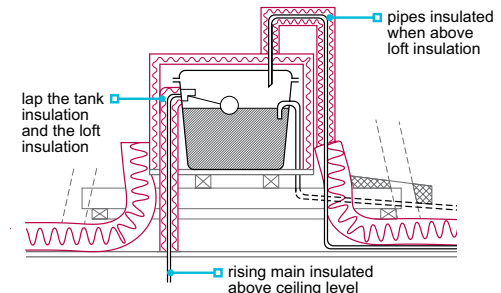

Figure 3: Pipe insulation thickness

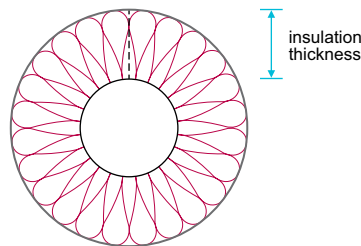

Table 1: Minimum insulation thickness to delay freezing inside domestic premises for cold water systems taken from BS 5422:2009 Table 30 (see Figure 3).

Outside diameter (mm)	Thermal conductivity at 0°C W/(m.K)			
	0.025	0.035	0.045	0.055
	Thickness of thermal insulation (mm)			
15	30	62	124	241
22	12	20	30	43
28	8	12	17	23

The conditions assumed for the table are:

- air temperature -6°C
- water temperature +7°C
- permitted ice formation 50%
- evaluation period 12 hours
- installation inside the building
- for practical reasons, if the pipe and insulation diameter are too large to be applied in practice, insulation with a lower thermal conductivity should be used.

Table 2: Examples of insulating materials:

Thermal conductivity W/(m.K)	Material
Less than 0.020	Rigid phenolic foam
0.021 to 0.035	Polyurethane foam
0.040 to 0.055	Corkboard
0.055 to 0.07	Exfoliated vermiculite (loose fill)

Where the floor is of suspended construction, the underfloor water service should be insulated as it passes through the ground and the ventilated space (see Figure 4).

Figure 4: Underfloor water supply pipe insulation

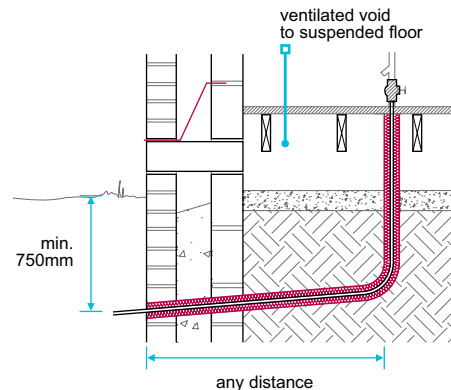

8.1.3.5 Wholesome water

There must be suitable installation for the provision of wholesome water to any place where drinking water is drawn off.

8.1.3.6 Water efficiency

Water efficiency should be accounted for in any design to prevent waste and undue consumption.

This can either be by a fittings approach or a water efficiency calculator or other approved method acceptable to NHBC.

8.1.4 Cold water storage

Cold water storage shall be provided in accordance with statutory requirements and be adequate. Issues to be taken into account include:

- | | |
|-----------------------|-------------------------------|
| 1) cold water storage | 4) warning and overflow pipes |
| 2) cisterns | 5) access. |
| 3) cistern support | |

8.1.4.1 Cold water storage

Cold water storage should be provided with suitable capacity and include primary feed cisterns where indirect water heating systems are installed. Cold water storage should be provided:

- to supply an open vented hot water storage system (where required by the water supplier)
- to supply cold water outlets (where not connected to the mains supply)
- to prevent undue consumption, contamination and water wastage.

8.1.4.2 Cisterns

Cisterns should:

- be accessible for inspection and maintenance
- be protected by a rigid close-fitting cover (non-airtight) that also excludes light and insects
- have holes neatly formed with a cutter in the positions shown in the design
- be suitably supported.

8.1.4.3 Cistern support

The cistern bottom should be continuously supported by materials such as:

- softwood boarding
- plywood to BS EN 636-2s
- chipboard type P5 to BS EN 312
- oriented strand board type OSB3 to BS EN 300, laid with the stronger axis (as marked on board) at right angles to the bearers.

8.1.4.4 Warning and overflow pipes

Warning and overflow pipes should:

- be provided at each cold water cistern, to a suitable external discharge, unless permitted by water regulations where it may be internal if it is conspicuous
- be adequately sized (19mm internal diameter (ID) minimum)
- be situated 25mm above the shut-off water level in the cistern
- be in accordance with water regulations, terminate vertically downwards or be fitted with a horizontal tee where it discharges (and may dip below the water level where permitted by the water regulations).

8.1.4.5 Access

Also see 7.2.12

Access for cold water storage should:

- be provided to the main roof space and voids that contain cisterns and tanks, etc (not required to roof spaces containing only water pipes)
- be via an opening (access hatch), with a minimum width of 520mm in each direction
- not be located directly over stairs or in other hazardous locations
- include a minimum 1m² platform located for maintenance purposes
- be located for maintenance purposes.

Boarded walkways and working platforms should be securely fixed with a minimum clearance of 50mm between the top of the insulation and the underside of the walkway to ensure a clear ventilation space.

8.1.5 Gas services

Also see: Chapters 6.2, 6.8, 8.6 and BS 6400 and BS 6891

Gas service installations shall be adequate and comply with the gas safety regulations and be in accordance with relevant standards and codes to ensure safe and satisfactory operation. Gas service installations should take into account:

- 1) gas service installation
- 2) corrugated stainless steel tube (CSST).

8.1.5.1 Gas service installations

Gas service installations should ensure:

- service pipework up to and including the emergency control valve and meter is in accordance with the requirements of the gas transporter, gas supplier and primary meter owner
- installation of pipework and appliances complies with relevant standards and codes, including those published by the Institution of Gas Engineers and Managers (IGEM), British Standards Institution (BSI) or Gas Safe Register (GSR)
- where there is a gas supply to the home, a gas point at the cooker space is provided (this is not required where an electric hob is provided)
- where gas pipework is to be installed in timber frame, allowance is made for differential movement
- installation of gas pipes will not impair the structural stability, fire/smoke resistance, damp proof course, radon barrier, hazardous ground membrane, thermal or sound insulation of the building
- gas installation pipes are not over bent, stressed or installed where subject to mechanical damage (see Figures 5-9).

Figure 5: Masonry brick and block plastered

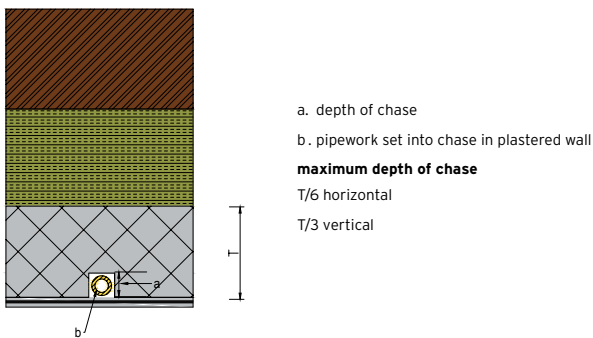

Figure 6: Dry lined walls on batons

CSST pipes installed behind dry lining shall be encased by building material

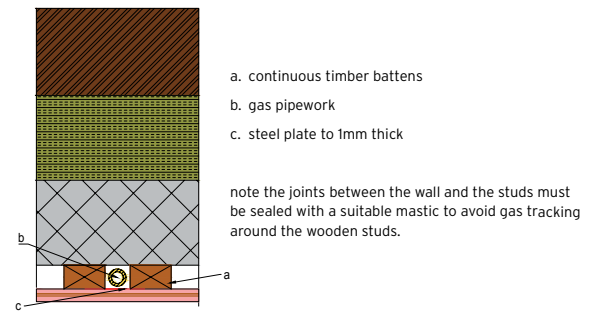

Figure 7: Dry lined walls on dabs

CSST pipes installed behind dry lining shall be encased by building material

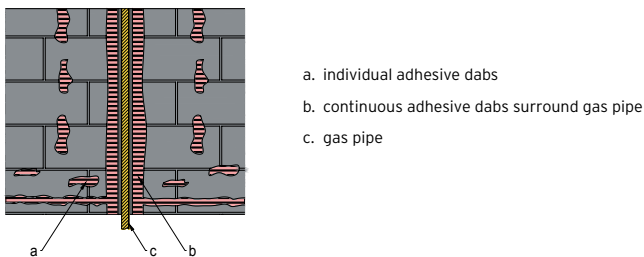

Figure 8: Timber frame or light steel construction wall

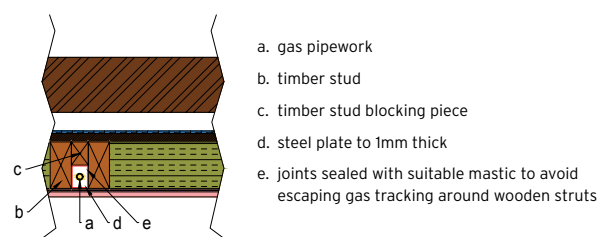
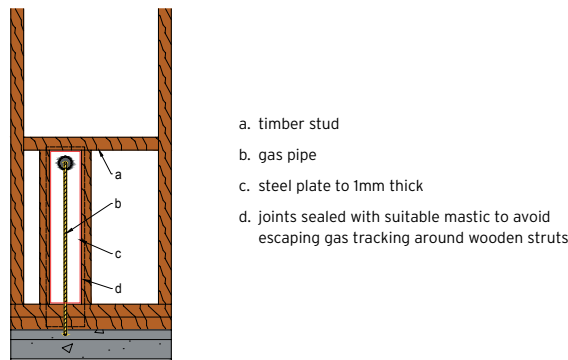

Figure 9: Installed in a timber frame or light steel construction wall



8.1.5.2 Corrugated Stainless Steel Tube (CSST)

Gas pipe installations Incorporating CSST should:

- conform to the CSST benchmark scheme with secondary cover for use as a secondary containment or BSI PP1644 flexible ventilated ducting for corrugated stainless steel tubing
- be certified by a UKAS accredited test body and tested in accordance with BS EN ISO 13823 and BS EN ISO 11925-2 and classified in accordance with BS EN 13501-1 and achieve B-s1, d0 or better
- be adequately supported in line with manufacturers' recommendations
- not be mixed with other proprietary brands of CSST or fittings
- not be buried in concrete floors, unless it is appropriate for the application, and the manufacturer confirms it is suitable for this purpose.

CSST without ducting shall meet the "tightness in case of fire requirements" of BS EN 15266, test method BS EN 1775 Annex A procedure A.

Where any pipe ducting is used that is intended to be fire resistant, it should be at least the same level of fire resistance as the protected area it is installed in. The fire resistance of the ducting shall be tested, evaluated and fire rated to the relevant parts of BS 476-24.

8.1.6 Electrical services

Also see: Chapter 8.6

Electrical installations shall be provided in accordance with relevant regulations, codes and standards. The installation shall ensure safe and satisfactory operation, and be protected from chemical attack.

Items to be taken into account include:

- | | |
|--------------------------|---|
| 1) installation | 9) metal splashbacks |
| 2) provision of sockets | 10) electrical supply to gas appliances |
| 3) cable positions | 11) TV |
| 4) consumer units | 12) smoke and heat alarms |
| 5) fire rated partitions | 13) electric vehicle charging points |
| 6) lighting outlets | 14) electronic communications |
| 7) cooking spaces | 15) lightning protection. |
| 8) built-in appliances | |

8.1.6.1 Installation

Electrical services and installations should:

- comply with BS 7671 Requirements for electrical installations
- comply with BS 6004 Electric cables. PVC insulated and PVC sheathed cables for voltages up to and including 300/500 V, for electric power and lighting
- have fittings and components located in accordance with relevant Building Regulations
- be installed in accordance with the manufacturer's recommendations
- ensure cables are not placed under, against or within thermal insulation, unless they have been appropriately sized and derated
- ensure PVC covered cables are not in contact with polystyrene insulation
- be provided with a completion certificate by the electrical contractor to the builder (covering all aspects of the installation, including earth bonding)
- incorporate appropriate automatic devices for protection against overcurrent or leakage. Where electrical items contain electronic components or create a Direct Current (DC) waveform in an Alternating Current (AC) supply, the Residual Current Device (RCD) should be a suitable type to prevent nuisance tripping, eg heat pumps, solar photovoltaic, micro wind, electric vehicle charging points, circulating pumps or induction hobs, USB charging sockets
- be supported such that they will not be liable to premature collapse in the event of a fire where hanging across access or egress routes. This can be achieved by using steel containment systems (either in or on) and precludes the use of non-metallic cable clips or ties as the sole means of support where cables are clipped direct to exposed surfaces. Suitably placed steel or copper clips, or saddles would be acceptable. (Plastic wall plugs with a steel clip will be acceptable if suitably sized for the screw and load)

- be earthed, where electrical sockets, fused spurs or light switches use metal back boxes that are fully recessed and covered by the faceplate. The earth terminal on the sockets should be used to connect the earth wire to. If no earth terminal is provided, as in the case of a light switch, the metal back box requires earthing
- not leave exposed wiring for homeowners to connect their own electrical fittings after occupation. All cables should terminate in a suitable proprietary electrical enclosure complying with the appropriate British Standard such as a recessed back box with cover or a temporary light fitting, for example a batten lamp holder
- be sited to provide reasonable access to homeowners as shown in Table 5.

Table 3: Minimum height of switches/sockets and controls

Region	Height of switches/sockets and controls above floor level
England Approved Document M1	450mm - 1,200mm
Wales Approved Document M1	450mm - 1,200mm
Scottish Technical Handbook 4.8.5	400mm - 1,100mm
Northern Ireland Technical Booklet R	400mm - 1,200mm

8.1.6.2 Provision of sockets

Rooms should be provided with the minimum number of 13A outlets listed in Table 4 (dual outlets count as two).

Table 4: Minimum number of outlets

Room	Outlets	Notes
Kitchen/utility	8	Where homes have separate areas, the kitchen should have a minimum of four outlets and the utility room four. Where appliances are provided, a minimum of three outlets should be free for general use
Living or family room	8	A minimum of two outlets near the TV aerial outlet
Bedrooms	6 (4)	A minimum of six outlets for the main bedroom and a minimum of four outlets for other bedrooms
Dining room	4	
Landing	2	
Hall	2	

8.1.6.3 Cable positions

Cables without special protection, such as an earthed metal conduit, should be positioned:

- vertically or horizontally from the outlet or switch being served
- within the shaded zone in the diagram (see Figure 10), or
- a minimum of 50mm from the surface of a wall, or a minimum of 50mm from the top or bottom of a timber joist or batten in a floor or ceiling.

Where the position of switches or sockets can be determined from the reverse side of the wall or partition, the zone on one side of the wall or partition applies to the reverse side.

Figure 10: Safe location of cables

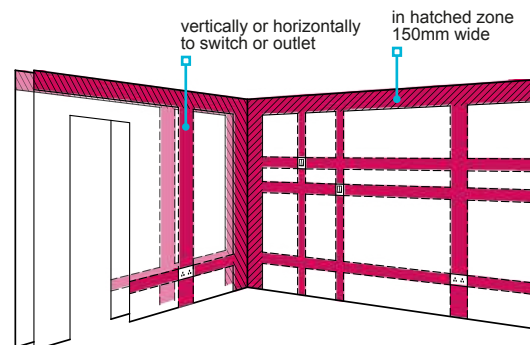

8.1.6.4 Consumer units

Consumer units should:

- have their enclosure manufactured from non-combustible material or be enclosed in a cabinet or enclosure constructed of non-combustible material (ferrous metal, eg steel, is deemed to be an example of non-combustible material)
- be compliant with BS EN IEC 61439-3 and, where installed for use by ordinary persons have an IP2XC rating
- not have any gaps between blanking pieces and circuit breakers larger than IP2XC requirement (hazardous parts within the enclosure cannot be contacted by a wire probe 2.5mm diameter and 100mm long)
- provide space for the installation and subsequent repair or replacement in line with manufacturers' recommendations
- be sited to provide reasonable access to homeowners.

Table 5: Minimum height of consumer units

Region ⁽¹⁾	Minimum height of consumer unit switches above floor level
England Approved Document M4(2)	1,350mm - 1,450mm
Wales Approved Document M1	1,200mm - 1,400mm

Note

1. Where no standards are provided by Building Regulations then follow guidance of BEAMA.

- where multiple rows of consumer units are utilised BEAMA recommends the bottom row of switches are located at a height of between 1,350mm - 1,450mm
- be labelled such that each circuit protected by a fuse or circuit breaker can easily be identified
- where labels/notices are not provided, the Electrical Installation Certificate, complete with guidance for recipients as detailed in Appendix 6 of the IET Wiring Regulations should be made available for inspection on site
- where labels/notices are fitted, they should be fixed in a permanent position at or near the origin of every installation. The most convenient location for these notices is usually on the consumer unit. Any notice should be of a durable material and indelibly marked (see Figure 11).

Figure 11: Notice examples

For periodic inspection and testing the label shall read as follows:

Important
This installation should be periodically inspected and tested and a report on its condition obtained, as prescribed in BS 7671 Requirements for Electrical Installations
Date of last inspection.....
Recommended date of next inspection.....

Where RCDs are provided, a label shall read as follows:

Important
This installation, or part of it, is protected by a device which automatically switches off the supply if a fault develops. Test six-monthly by pressing the relevant test button(s) which should operate the device. Afterwards, manually switch on the device. If the device does not operate, or indicates a fault, seek expert advice.

- Have a minimum of 300mm measured horizontally to the edge of any bowl of a sink or wash basin opening to avoid splashing from the sink or basin. General guidance is to avoid positioning a consumer unit immediately above or alongside a sink and, where space exists, an accessory should be located beyond the drainer (see Figure 12).

Figure 12: Horizontal distance of electrical items to sinks

Diagram 1 - wash basin

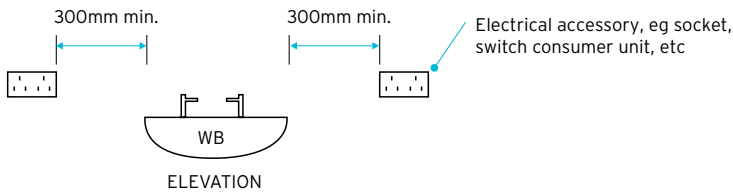
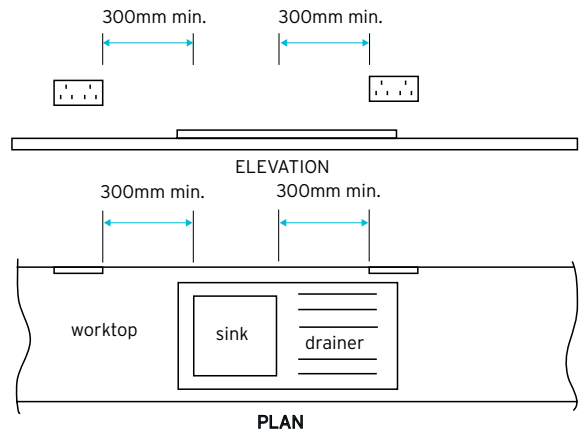

Diagram 2 - sink



8.1.6.5 Fire rated partitions

Electrical installations installed in fire rated partitions should:

- comply with the requirements for cable, conduits, sockets and provision as specified in BS 7671
- not impair the fire resistance of the structure to any means of escape. The provision of any electrical item must maintain the integrity of the compartmentation of the original building design
- where intumescent pads (putty pads) or lined backing boxes are used, they should hold satisfactory assessment, in accordance with R3a ii, have an appropriate period of fire resistance, be suitable for the intended application and be used in accordance with the manufacturer's recommendations.

8.1.6.6 Lighting outlets

Lighting outlets should be provided:

- in each room, hall, landing and staircase
- with two-way switching at each floor level in a staircase
- in the common areas of homes and controlled by either manual switching or automatic light-sensitive controls.

8.1.6.7 Cooking spaces

Cooking spaces should:

- have a minimum 30A supply which is suitably switched and terminated
- have a 13A socket outlet where there is a gas supply
- where provided, have cooker panels located to the side of the cooker space
- have a minimum of 100mm measured horizontally from an electrical accessory to the edge of a freestanding cooker or individual hob (see Figure 13).

Figure 13: Horizontal distance of electrical items to hobs

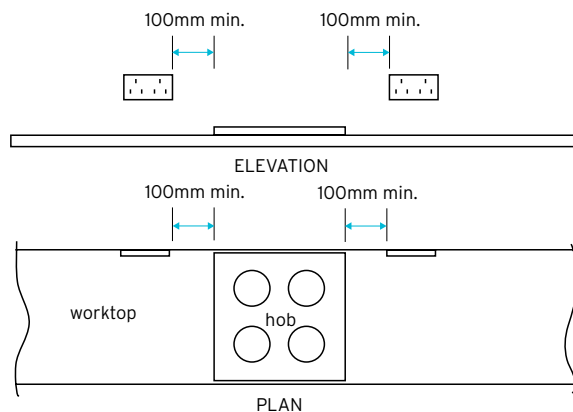

8.1.6.8 Built-in appliances

Where appliances are built in:

- isolation should be reasonably accessible and in compliance with the manufacturer's recommendations
- disconnection points should always be local to the appliance to enable isolation without affecting the use of other electrical appliances or equipment in the same circuit
- disconnection should not require the removal of the appliance from its housing to access and operate.

8.1.6.9 Metal splashbacks

The Institute of Electrical Engineers has confirmed that earth bonding is not required to metal splashbacks in kitchens, including those splashbacks containing electrical accessories such as socket outlets.

8.1.6.10 Electrical supply to gas appliances

Also see: Clause: 8.3.2.7

Where a gas appliance requires an electrical supply, a suitable fixed spur or socket outlet should be provided.

8.1.6.11 TV

Aerials are not required; however, one of the following should be provided:

- a concealed, coaxial cable from the roof void to a terminal outlet in the main living room
- a conduit and draw wire or suitable alternative.

8.1.6.12 Smoke and heat alarms

Smoke and heat alarms should be provided in accordance with relevant Building Regulations.

Where additional measures are required by the design the following consideration should be taken into account and have a mains power supply from either:

- an independent circuit with no other electrical equipment connected other than a dedicated social alarm control unit or a mains-powered carbon monoxide (CO) alarm interlinked, if the manufacturer's instructions allow this
- a separately electrically protected regularly used lighting circuit, in which case, there should be a means of isolating the smoke alarm from the lighting circuit for maintenance.

If more than one smoke alarm is interconnected, they should all be isolated by one single circuit (unless the interconnection is via remote communication).

Where used, smoke alarms should be labelled appropriately to prevent the device being inadvertently disconnected. Labels should be:

- provided to any isolator stating, "smoke alarm is fitted, do not switch off"
- provided to any lighting circuit isolator stating, "caution, smoke alarms connected to this circuit, do not switch off".

8.1.6.13 Electric vehicle charging points

Where electric vehicle charging points are installed, consideration should be given to:

- Technical Requirements
- product certification
- operative competency
- manufacturers' instructions
- location to not cause hazard or nuisance
- serviceability.

8.1.6.14 Electronic communications

Where electronic communications are installed, consideration should be given to:

- Technical Requirements
- distribution point
- common access point
- public electronic communications networks.

8.1.6.15 Lightning protection

Lightning protection, where used, should comply with the relevant standards and be appropriate for the location installed:

BS EN 62305-1-5	Protection against lightning
PD 62305-2:2014	Flash density map 2014. Supplement to BS EN 62305-2:2012. Protection against lightning. Risk management
BS EN IEC 62561-1	Lightning protection system components
BS EN IEC 62561-2	Lightning protection system components
IEC 60068-2-52	Environmental testing: salt mist, cyclic (sodium chloride solution)
IEC ISO 6957	Copper alloys: ammonia tests for stress corrosion resistance
ISO 22479	Corrosion of metals and alloys — sulfur dioxide test in a humid atmosphere

8.1.7 Meter boxes

Also see: Clause: 6.1.17

Openings in walls for meter cabinets shall be structurally adequate and prevent dampness entering the home.

Meter boxes and associated equipment should be located to be reasonably accessible and not subject to damage; guidance should be sought from the appropriate Gas Distribution Network Operator (GDNO) and/or Distribution Network Operator (DNO) for electrical installations. Issues to take into account include:

- 1) domestic meter boxes
- 2) openings.

8.1.7.1 Domestic meter boxes

Domestic meter boxes may be of the following type:

- built-in (to the outer leaf of the wall)
- surface-mounted (on an external wall).

Incoming supply to the meter box should be in accordance with the service provider's requirements.

8.1.7.2 Openings

Openings set into external walls should be:

- provided with DPCs and cavity trays (see Clause 6.1.17 for further guidance and Figure 14)
- provided with lintels (except for purpose-designed built-in meter boxes)
- provided with insulation carried past meter box to avoid cold bridging (any reduction in thickness to be accounted for in the thermal assessment of dwelling)
- have weephole positions/openings located in a perp joint (see Figure 15)
- installed in accordance with DNO and/or GDNO with relation to ventilation openings.

Figure 14: Cavity tray with inset meter box

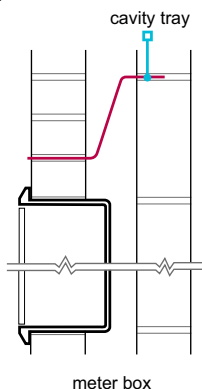
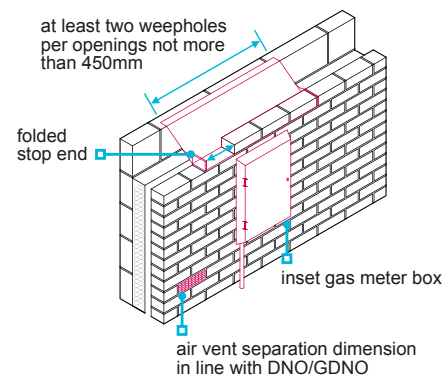

Figure 15: Weephole position with inset meter box



8.1.8 Hot water services

Also see: Chapter 8.6 and BS 8558

Hot water services shall be provided in accordance with statutory requirements and be adequate for the demand and consumption. Issues to be taken into account include:

- 1) design
- 2) location
- 3) immersion heaters
- 4) vented storage cylinders.

8.1.8.1 Design

Hot water services should be designed in accordance with Tables 6, 7 and 8, and:

- the minimum flow rate should be in accordance with the statutory requirements and generally be available; it may be less where the pressure and flow rate of the incoming supply falls below 1.5 bar
- have the design flow rate available at each outlet when the total demand does not exceed 0.3L/sec (where simultaneous discharge occurs, the flow rate at individual outlets should not be less than the minimum rate).

Table 6: Flow rate and temperature requirements

Outlet	Design flow rate ⁽¹⁾		Minimum flow rate ⁽²⁾		Supply temperature °C ⁽³⁾
	L/sec	(L/min)	L/sec	(L/min)	
Bath (from storage)	0.30	(18)	0.15	(9)	48
Bath (from combi)	0.20	(12)	0.15	(9)	40
Shower (non-electric)	0.20	(12)	0.10	(6)	40
Wash basin	0.15	(9)	0.10	(6)	40
Sink	0.20	(12)	0.10	(6)	50

Notes

1. The design flow rate should be used to establish the hot and cold pipe sizes to provide the flow rate quoted at each outlet when that outlet is used on its own.
2. The minimum flow rate should be available at each fitting when that fitting is used simultaneously with one or more other fitting(s) as shown in Table 4.
3. The supply temperature is the temperature at the outlet. In accordance with BS 8558, the water temperature at an outlet or thermostatic mixing valve should be at least 50°C within one minute of running the water.

Table 7: Hot water demand and simultaneous use

Bathroom		Shower room		Hot water demand ⁽⁵⁾	
Bath only	Bath + shower ⁽¹⁾	1st shower room	2nd shower room	L/sec	(L/min)
✓ ⁽²⁾				0.20	12
		✓ ⁽³⁾		0.15	9
✓		✓		0.25	15
✓		✓	✓	0.35	21
	✓ ⁽²⁾			0.20	12
	✓ ⁽⁴⁾	✓		0.20	12
	✓ ⁽⁴⁾	✓	✓	0.30	18
		✓	✓	0.20	12

Notes

1. Shower may be over the bath or in a separate enclosure within the bathroom.
2. Demand based on 'design' flow rate of bath.
3. Demand based on minimum acceptable boiler output.
4. Demand based on use of the shower in preference to the bath.
5. The hot water system should supply at least the hot water demand stated and take account of distribution heat losses through the pipework. The suitability of instantaneous systems (combination boilers) will be limited by their performance as quoted by the boiler manufacturer.

Hot water storage should comply with the minimum capacity in Table 8 (based on a draw-off temperature of 60°C), and where appliances require greater volumes, the capacity should be increased accordingly.

The volumes shown in Table 8 are calculated using Annex B BS 8558. Volumes have been rounded to common cylinder volumes available.

Table 8: Minimum storage requirements

Usage example	Heat input to water at 60°C					Cylinder type
	3kW	6kW	10kW	15kW	20kW	
One shower (smaller dwelling)	60L	60L	60L	60L	60L	With stratification
One shower (smaller dwelling)	90L	90L	90L	90L	90L	With mixing
One bath (small dwelling)	120L	100L	90L	90L	90L	With stratification
One bath (small dwelling)	150L	100L	90L	90L	90L	With mixing
One bath + separate shower (larger dwelling)	165L	140L	130L	120L	120L	With stratification
One bath + separate shower (larger dwelling)	260L	210L	130L	130L	130L	With mixing
Two baths (larger dwelling)	165L	140L	130L	120L	120L	With stratification
Two baths (larger dwelling)	260L	210L	130L	130L	130L	With mixing

Where systems are heated by off-peak electricity, the storage capacity should be in accordance with the recommendations of the electricity supplier.

Where homes have one bathroom or shower room, the system should be able to provide adequate hot water:

- immediately after the bath has been filled, for tasks such as washing
- for a second bath after 30 minutes.

Where homes have two or more bathrooms, the system should be able to provide adequate hot water immediately after each of the baths have been filled, for tasks such as washing.

Where a shower is installed, adequate provision should be made to ensure that the outlet temperature of the water is not significantly affected by the use of other hot or cold outlets in the home. This may be achieved by the provision of a thermostatic shower mixing valve, the appropriate design of pipe sizes or dedicated supplies.

Instantaneous systems (using combination boilers) produce hot water on demand (generally at lower flow rates than storage systems) and should only be used where:

- simultaneous demand for hot water is limited. Where there are three or more outlets, the design for simultaneous discharge can omit the outlet at the kitchen sink
- storage combination boilers have the capacity as required in Table 8. Where boilers can control and prioritise hot water outputs the storage capacities can be less than the figures in Table 8 subject to manufacturers' recommendations on meeting the demand.

8.1.8.2 Location

Storage systems weight will vary by size of storage demand designed; the installation should be:

- a suitable space for the siting of the storage vessel to allow for installation
- supported in accordance with manufacturer's recommendations
- installed vertically, unless designed otherwise
- accessible for maintenance, service, repair and replacement
- insulated as specified in the design.

8.1.8.3 Immersion heaters

Where an immersion heater is fitted, it should be:

- appropriate for the type of water supplied to the home
- controlled by a thermostat
- located to facilitate replacement
- supplied with an energy cut-out device to prevent overheating
- suitable for the water quality on-site
- fitted with an on/off switch.

8.1.8.4 Vented storage systems

Vented storage systems should be provided with a correctly sized expansion pipe that terminates into a correctly designed, supported and insulated supply tank.

8.1.9 Unvented storage systems

Unvented storage systems and discharge pipework shall be in accordance with relevant regulations. Be securely fixed and any discharge pipes terminate in a safe visible position. Issues to be taken into account include:

- 1) product certification
- 2) discharge pipework
- 3) low level discharge
- 4) high level discharge
- 5) discharge pipework material.

8.1.9.1 Product certification

Unvented hot water storage systems should be:

- assessed in accordance with Technical Requirement R3, or meet the requirements of BS EN 12897 and be the subject of third-party certification (applies to both the assembled system and components)
- installed by competent installers.

8.1.9.2 Unvented storage system discharge pipework

Discharge pipework should:

- terminate in a safe and visible position
- have the tundish as close to the storage system as possible in a visible position
- not be connected to other waste connections
- not terminate inside garages
- be sized appropriately in line with national standards
- be adequately supported
- be installed with a fall to outside in line with the manufacturer's recommendations.

8.1.9.3 Low-level discharge

Low-level discharge should be:

- into a gully below the grating but above the water level (see Figure 16).

Onto the ground (drive, path or garden area) the pipe should discharge downwards and be no more than 100mm above ground level. The discharge should be protected against the discharge being touched with fingers or hand before it has hit the ground. This is normally achieved by installing a cage over the discharge pipe (see Figure 17).

Figure 16: Low-level unvented discharge — trapped gully

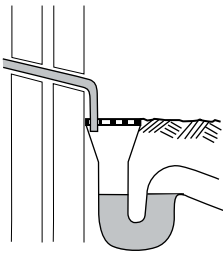
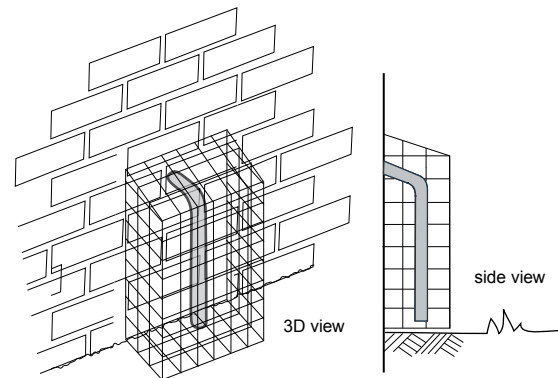

Figure 17: Low-level unvented discharge — path or garden area



8.1.9.4 High-level discharge

High-level discharge is only acceptable when:

- it terminates onto a flat or pitched roof capable of withstanding water at high temperature
- the termination is 3m away from plastic guttering
- terminating into a metal hopper head and downpipe which in turn terminates safely and discharge at low level.

8.1.9.5 Discharge pipework material

The normal material for discharge pipework is metal.

When thermoplastic pipes or fittings or similar equipment is used, compliance with R3 is required. They should have a satisfactory assessment by an appropriate independent technical approvals' authority accepted by NHBC.

Waterless traps and waste pipes should comply with the marking requirements of BS 7291-1 Thermoplastic pipes and fittings for hot and cold water for domestic purposes (see Figure 18).

Figure 18: Unvented discharge — soil stack

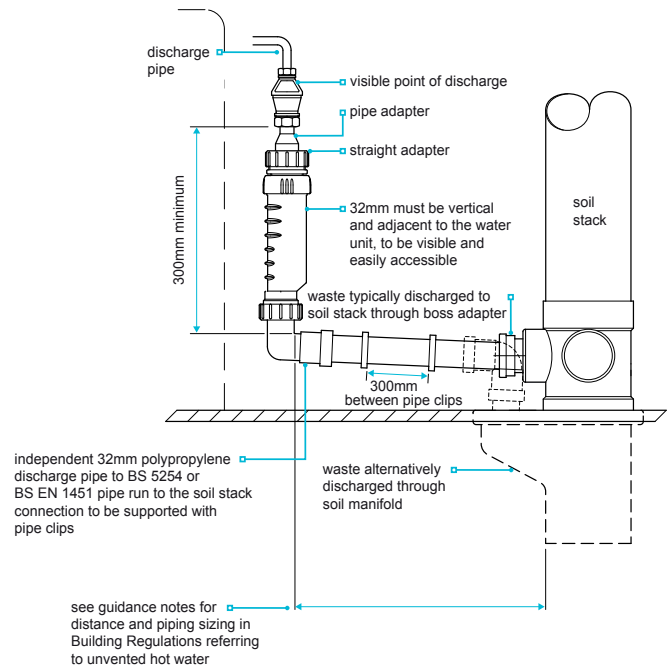

8.1.10 Internal soil and waste systems

Also see: Clause 6.3.7

Soil and waste systems shall be in accordance with relevant Building Regulations and installed to ensure that effluent is removed without affecting health or creating unnecessary noise and smell. Items to be taken into account include:

- | | |
|---|----------------------|
| 1) relevant standards | 4) sanitary fittings |
| 2) air admittance valves | 5) waste disposal |
| 3) sound insulation to soil and vent pipe | 6) junctions. |

Soil and waste systems should be:

- in accordance with the requirements of the water supplier
- adequately ventilated at the head of underground drains (this may be by a soil pipe or separate ventilation pipe)
- adequately ventilated at each branch
- arranged to ensure foul air from the drainage system cannot enter homes (eg ventilated to 900mm above openings when within 3m)
- fixed neatly and securely to provide the correct falls
- fitted to prevent the entry of vermin.

8.1.10.1 Relevant standards

Relevant standards for domestic soil and waste systems include:

BS EN 752	Drain and sewer systems outside buildings
BS EN 12056-1	Gravity drainage systems inside buildings — General and performance requirements
BS EN 12056-2	Gravity drainage systems inside buildings — Sanitary pipework, layout and calculation
BS EN 12056-3	Gravity drainage systems inside buildings — Roof drainage, layout and calculation
BS EN 12056-4	Gravity drainage systems inside buildings — Wastewater lifting plants. Layout and calculation
BS EN 12056-5	Gravity drainage systems inside buildings — Installation and testing, instructions for operation, maintenance and use

8.1.10.2 Air admittance valves

Air admittance valves should:

- be used to allow air to enter the drainage system (but do not avoid the need to ventilate it adequately)
- comply with BS EN 12380 or be assessed in accordance with Technical Requirement R3 (see Figure 19)
- not be positioned in areas which are liable to freezing
- have free movement of air around them which can be achieved by ventilation grilles, discreet gaps around the boxing or ventilation of the boxing into a ventilated roof void (the ventilation area should be 2,500mm² minimum unless otherwise specified by the manufacturer — see Figure 19)
- where positioned within the home, be accessible for maintenance.

Figure 19: Air admittance valves

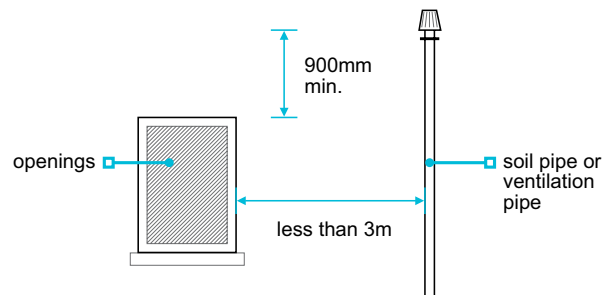

8.1.10.3 Sound insulation to soil and vent pipes

All sections of soil and vent pipe, including those in bathrooms or ground floor stub stacks, should be soundproofed to limit the transmission of noise (see Figure 20).

Where soil and vent pipes run horizontally through a floor void above or below a habitable room, they should be:

- wrapped in at least 25mm of mineral wool (10kg/m³ min)
- adequately supported to avoid contact with the floor decking or ceiling.

Sound insulation should be provided to soil pipes passing through homes by:

- an encased boxing, using material (15kg/m²) and
- wrapping the pipe with a minimum 25mm of unfaced mineral wool (10kg/m³ minimum — the insulation should be continued through the thickness of each sound-insulating floor).

Soil and vent pipes which hold a satisfactory assessment by an appropriate independent technical approvals' authority acceptable to NHBC may be acceptable where the requirements of the Building Regulations are achieved.

Figure 20: Sound insulation to soil and vent pipes

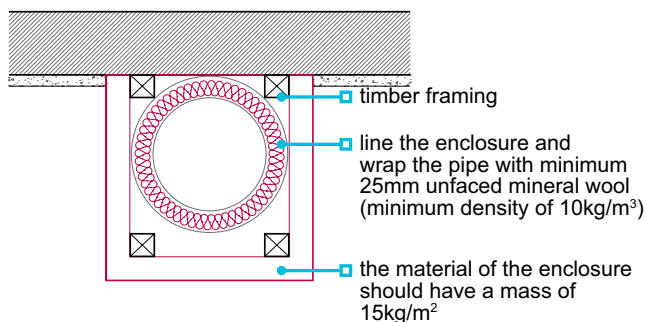

8.1.10.4 Sanitary fittings

Sanitary fittings should be:

- installed with accessories, such as chains and plugs
- secured using non-ferrous or stainless steel screws or fixings appropriate to the weight of item being secured
- fitted without using excessive packing
- fitted to ensure WC lids and seats are stable when open.

8.1.10.5 Waste disposal

Waste disposal units should be:

- provided with adequate support
- fitted with a tubular trap (not bottle or resealing)
- connected to the drainage system in accordance with the manufacturer's recommendations.

8.1.10.6 Junctions

The junctions of wall tiling with baths and showers should be made watertight using a flexible sealant to accommodate movement. The manufacturer's instructions should be followed.

8.1.11 Further information

- *BS 6400 Specification for installation, exchange, relocation, maintenance and removal of gas meters*
- *BS 6891 Specification for the installation and maintenance of low pressure gas installation pipework of up to 35mm*



Chapter 8.2



Electrical generating technologies

This chapter provides guidance for outgoing utilities that generate electricity from low or zero carbon sources (LZC) for home use, storage or export. Other LZC systems that follow the general principles of this chapter may also be acceptable, subject to specific agreement with NHBC.

This chapter contains the following sections:

- 8.2.1 Solar photovoltaics (PV)**
- 8.2.2 Wind turbines**

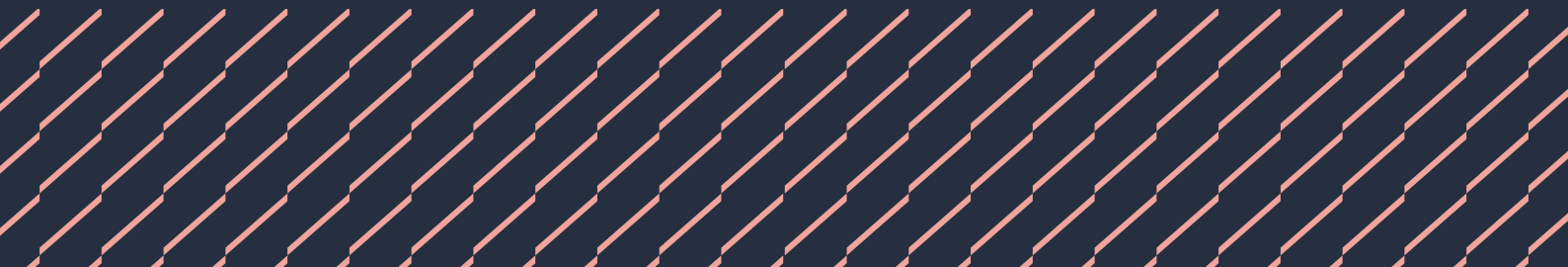



Chapter

8.2.1



Solar photovoltaics (PV)

Systems which convert solar radiation into electricity.

8.2.1.1	Compliance	02
8.2.1.2	Provision of information	03
8.2.1.3	System design	03
8.2.1.4	Building integration	05
8.2.1.5	Fixing	06
8.2.1.6	Access	06
8.2.1.7	Electrical installation requirements	06
8.2.1.8	Handling and storage	07
8.2.1.9	Sequence of work	07

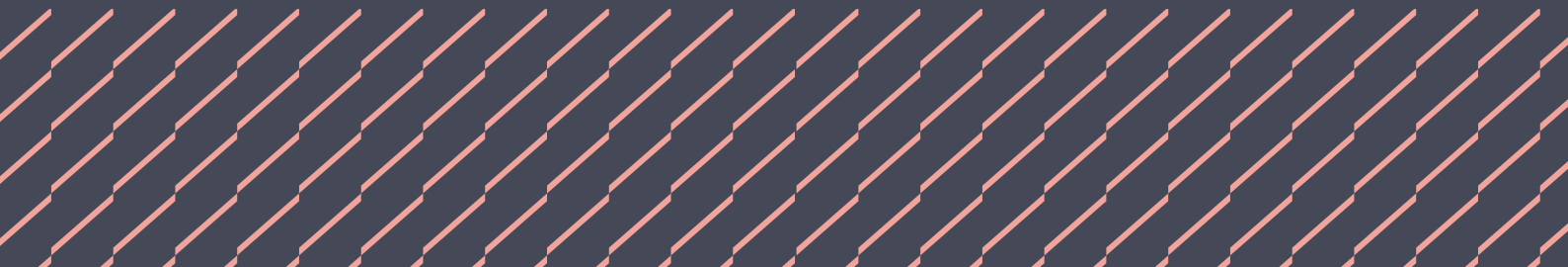

Figure reference table

Figure Reference Table 8.2.1

Fig No	Title/Description	Chapter/Clause	Page
Figure 1	Solar PV schematic	8.2.1	2
Figure 2	Solar PV schematic with battery	8.2.1	2
Figure 3	Solar PV types	8.2.1.4	5

Figure 1: Solar PV schematic

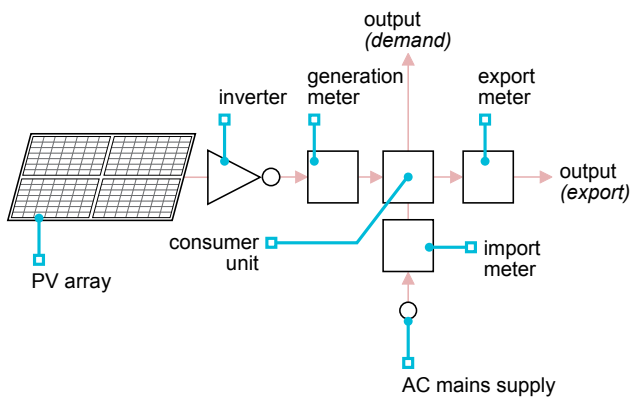
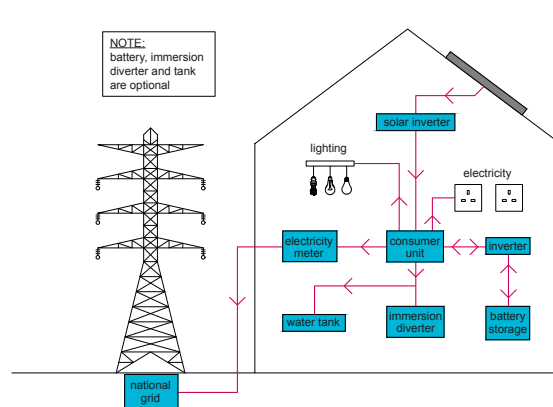

Figure 2: Solar PV schematic with battery



Definitions for solar PV

Coastal locations	A site within a distance of 500m from the general coastline of the United Kingdom.
Controls	Used to operate and/or regulate the system, and may be electrical or mechanical.
Exclusion zone	An area where entry is restricted during periods when maintenance is in progress, to prevent risk of injury or loss of life.
Inverter	A device that converts direct current into alternating current.
Islanding (island mode operation)	Where an LZC technology feeds the network or local distribution system during a planned or unscheduled loss of mains supply.
Low or zero carbon (LZC) technologies	A term applied to renewable sources of energy, and also to technologies which are significantly more efficient than traditional solutions, or which emit less carbon in providing heating, cooling or power
Parallel electrical generation	A system in which building loads can be fed simultaneously from the national grid or electricity supply grid and on-site sources such as wind turbines and PV panels.
Performance	The manner or quality of functioning for a material, product or system.
Renewable energy	Energy from naturally available sources that can be replenished, including energy from the sun, wind and tides, and from replaceable matter such as wood or other plant material.
Switchgear	The combination of electrical switches, fuses and/or circuit breakers used to isolate electrical equipment.

8.2.1.1 Compliance

Also see: Chapter 2.1

Solar PV and ancillary equipment shall comply with the Technical Requirements. Issues to be taken into account include:

- 1) relevant standards
- 2) product certification
- 3) operative competency.

8.2.1.1.1 Relevant standards

Solar PV and/or batteries should comply with relevant standards including where applicable:

BS EN 61215-1	Terrestrial photovoltaic (PV) modules. Design qualification and type approval
BS EN 61215-2	Terrestrial photovoltaic (PV) modules. Design qualification and type approval — Test procedures
BS EN 60068	Environmental testing
BS EN IEC 61730	Photovoltaic (PV) module safety qualification
BS EN IEC 62108	Concentrator photovoltaic (CPV) modules and assemblies. Design qualification and type approval
MCS 005	Product Certification Scheme Requirements: Solar Photovoltaic Modules
MCS 012	The Roof Fixing Standard (Product)
MCS 3002	The Solar PV Standard (Installation)
MIS 3012	The MCS Battery Standard (Installation)
PAS 63100	Electrical installations — Protection against fire of battery energy storage systems for use in dwellings

8.2.1.1.2 Product certification

Solar PV and/or battery technologies should have current certification confirming satisfactory assessment by an appropriate independent authority acceptable to NHBC.

Solar PV products that are certified through the Microgeneration Certification Scheme (MCS) will generally be acceptable to NHBC. Certification and test documentation should be made available to NHBC upon request.

Other certification bodies or test documentation may be acceptable where they are considered by NHBC to be a suitable alternative.

8.2.1.1.3 Operative competency

Solar PV systems should be installed by companies, organisations or operatives who are:

- competent and familiar with the system being installed, and
- certified to a standard acceptable to NHBC.
- MCS Certified, or

8.2.1.2 Provision of information

Designs and specifications shall be produced in a clearly understandable format, include all relevant information and be distributed to the appropriate personnel.

Provision of information is important as it allows for energy-efficient use of the building and common methods adopted to prevent overheating.

Clear and fully detailed drawings should be available on site to enable work to be carried out in accordance with the design. Design and specification information should be issued to site supervisors, relevant specialist subcontractors and suppliers, and where used include the following information:

- fixing schedule
- a full set of current drawings
- indication of which manufacturer and/or installer is responsible for each system and interface
- commissioning schedule
- manufacturers' specifications
- interface details
- on-site testing requirements
- type and spacing of clips and fixings
- type and location of ancillary components, including those used for fire safety and acoustic purposes
- commissioning certificates
- wind load calculations
- snow load calculations.

8.2.1.3 System design

Solar PV technologies shall be designed to ensure satisfactory performance. Issues to be taken into account include:

- | | |
|------------------|-------------------------|
| 1) location | 4) performance |
| 2) system | 5) diverters |
| 3) compatibility | 6) battery and storage. |

8.2.1.3.1 Location

Solar PV systems should be correctly located, including ancillary components, and should be installed and identified in accordance with the manufacturer's recommendations.

The design and location of solar PV technologies should take account of factors such as:

- orientation
- roof pitch
- coastal location
- snow loading
- shading.

When installed in a coastal location, fixings and bracketry should be appropriate for the area, and stainless steel grade 316 should be used where appropriate.

8.2.1.3.2 System

Solar PV technologies should be designed in accordance with the manufacturer's recommendations, certification scheme requirements and appropriate standards.

Each system should generally be supplied from one manufacturer as a package, not as individual components or materials. However, where components from more than one manufacturer are used, they should be compatible to ensure satisfactory performance.

Mixing of electrical MC4 type connections (male and female) is not acceptable unless specifically allowed by the manufacturer.

8.2.1.3.3 Compatibility

Solar PV technologies should be installed so as not to adversely affect the performance of the building to which they are fixed, and in accordance with the manufacturer's recommendations.

Multiple systems should be compatible with each other.

The temperature rating of any roof underlay should be suitable for use with a solar PV system and accessories used.

When using roof integrated solar panels, ventilation must be maintained in accordance with BS 5250. Also see Clause 7.2.15.

8.2.1.3.4 Performance

Solar PV systems designed to contribute towards space and water heating should be designed in accordance with the performance requirements in Clauses 8.1.8 and 8.3.2.

8.2.1.3.5 Diverters

The provision of immersion diverters is discretionary. Where used, they should be designed by a competent person to prevent any adverse operation to the installed electrical installation either upstream or downstream, including RCD and islanding protection.

8.2.1.3.6 Batteries and storage

Also see: Clause: 8.1.6

The provision of battery storage is discretionary. Where used, it should be designed by a competent person and in conjunction with the IET Code of Practice for Electrical Energy Storage Systems and BS 7671 18th Edition wiring regulations and:

- the installation should be in line with MIS 3012 and manufacturer's installation instructions
- the inverters must be fully type tested to the standards required by the Energy Networks Association recommendations
- the batteries and storage equipment should not be located where they are at risk of accidental damage or where their enclosures are not designed for
- batteries intended for use in dwellings should be housed in a suitable enclosure meeting the relevant IPX rating
- batteries/storage should not be placed so that escape routes are impeded, and that any fire in the battery does not compromise protected escape routes
- where batteries are located they should have sufficient ventilation to prevent overheating and prevent explosive conditions of evolved gasses
- should not be designed and installed where foreseeable flood or water inundation conditions may occur.

Further guidance relating to battery installation can be found in PAS 63100 Electrical installations — Protection against fire of battery energy storage systems for use in dwellings.

8.2.1.4 Building integration*Also see: Clauses: 7.2.15, 7.2.17 and Chapter 8.6*

Solar PV technologies shall be securely fixed and not adversely affect the weather resistance of the building.

Foundations and anchor points for stand-alone LZC technologies should be designed by an engineer in accordance with Technical Requirement R5 to withstand the structural forces acting upon them.

The structure to which the LZC technology is attached should be assessed according to its ability to accept the loadings and prevent detrimental effects arising from movement or vibration.

The design of the structure should take account of:

- the self-weight of the LZC components
- imposed loads
- wind loads
- snow loads
- dynamic loading (where relevant)
- the atmospheric conditions ie, coastal locations.

Notching, drilling or chasing of structural components to accommodate service pipes or cables should either comply with Chapter 8.6 Installation and commissioning or be designed by an engineer in accordance with Technical Requirement R5.

Fixings, supports, bracketry and mounting frames should:

- accommodate all static and dynamic loads in accordance with the manufacturer's recommendations
- have adequate protection against corrosion (grade 316 stainless steel is recommended for coastal locations)
- be compatible or isolated where two metals are to be joined to prevent bimetallic corrosion.

All interfaces between the LZC technology and the building should ensure adequate weather resistance, and be sealed to limit air leakage and prevent moisture from reaching the interior or any part of the structure that could be adversely affected by its presence. The envelope should be weatherproofed using appropriate flashings and fixings. Weatherproofing details that rely solely on sealant are not acceptable. Flashings should be formed from the materials listed in Table 1.

Table 1: Materials for flashings

Flashing material	Guidance
Rolled lead sheet	Minimum thickness 1.8mm, code blue (Code 4), to BS EN 12588
Aluminium and aluminium alloys	BS EN 485 and BS EN 573, 0.6-0.9mm thick and protected from contact with mortar by a coating of bituminous paint
Zinc alloys	BS EN 988 and 0.6mm thick
Copper	BS EN 1172 0.55mm thick and fully annealed. Where two metals are to be joined, they should be compatible and not cause bimetallic corrosion in that environment. Alternatively, they should be isolated from each other
Proprietary flashing, including plastic and composite	Assessed in accordance with Technical Requirement R3

To avoid potential surface or interstitial condensation, the design should take account of thermal bridging, particularly where any part of the system, including fixings, penetrates the thermal envelope.

All installations should take into consideration rodent/bird damage, connector corrosion and potential damage caused by follow-on trades.

Figure 3: Solar PV types

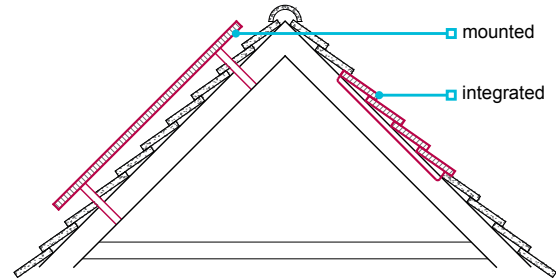

8.2.1.5 Fixing

Also see: Chapter 2.1

Solar PV technologies shall be fixed using durable materials.

Fixings should comply with the types listed in Table 2.

Table 2: Materials suitable for fixings

Fixing material	Guidance
Phosphor bronze	NA
Silicon bronze	NA
Stainless steel	BS EN ISO 3506
Mild steel	Coatings to BS EN ISO 2081, BS EN ISO 2082, BS EN 1461 or other appropriate treatment in accordance with BS EN ISO 12944 or BS EN ISO 14713
Aluminium alloy	BS EN 573 and BS EN 755
Stainless steel	BS EN 10088
Mild steel	BS EN 10346
Other materials	Assessed in accordance with Technical Requirement R3

Materials that comply with recognised standards, which provide equal performance to (or better than) those above, are also acceptable.

The type, size, number, position and fitting tolerance of fixings should be in accordance with the manufacturer's recommendations.

Issues that should be taken into account include:

- the provision of suitable locking nuts and washers
- the isolation of aluminium from cementitious material.
- the isolation of dissimilar metals

All components, including integrated roof trays, panels, flashings, electrical connectors and wiring, that penetrate the roof structure to the space below should be appropriately flashed and comply with the requirements of R3.

8.2.1.6 Access

Appropriate arrangements shall be provided for the purposes of cleaning, inspection, maintenance and repair or replacement of solar PV technologies.

Safe access should be provided to solar PV technologies, including switchgear, inverters, meters and controls. This is to enable the cleaning, inspection, maintenance and repair of systems. Access should be provided in accordance with the manufacturer's recommendations.

Where plant is to be installed in a loft or roof void, guidance is provided in Clause 7.2.12.

8.2.1.7 Electrical installation requirements

Also see: Clause 8.1.6

The electrical installation shall be in accordance with relevant regulations.

Electrical installations should comply with BS 7671 18th Edition wiring regulations.

Where parallel electrical generation occurs, inverters should have a relevant Engineering Recommendation G83/2 type test certificate and comply with all other parts of ER G83/2 for standard installations. Larger installations should comply with ER G59/3-2.

The electrical installation should be capable of being isolated from all other electrical sources when required, for maintenance or testing.

LZC technologies which generate electricity and are connected to the mains should automatically disconnect when there is a mains power failure. This is to prevent them from feeding the network or local distribution system during a planned or unscheduled loss of mains supply. This is known as 'islanding'.

Where lightning protection is included it should be installed in line with the standards listed in Table 3.

Table 3: Lightning protection standards

BS EN 62305-1-5	Protection against lightning
PD 62305-2:2014	Flash density map 2014. Supplement to BS EN 62305-2. Protection against lightning. Risk management
BS EN IEC 62561-1	Lightning protection system components
BS EN IEC 62561-2	Lightning protection system components
IEC 60068-2-52	Environmental testing: Salt mist, cyclic (sodium chloride solution)
IECISO 6957	Copper alloys: ammonia tests for stress corrosion resistance
ISO 22479	Corrosion of metals and alloys — sulfur dioxide test in a humid atmosphere

8.2.1.8 Handling and storage

Materials, products and systems shall be handled, stored and protected in a satisfactory manner to prevent damage, distortion, weathering and degradation.

Solar PV systems should be:

- transported, lifted, handled and stored in accordance with the manufacturer's recommendations
- delivered in sequence to avoid storage
- protected to avoid the risk of damage.

8.2.1.9 Sequence of work

Solar PV systems shall be installed in accordance with a suitable schedule.

To ensure performance, solar PV systems and ancillary components should be installed in a logical and timely sequence in accordance with the manufacturer's recommendations.



Chapter

8.2.2



Wind turbines

Systems which convert wind into electricity.

8.2.2.1	Compliance	10
8.2.2.2	Provision of information	11
8.2.2.3	System design	11
8.2.2.4	Building integration	13
8.2.2.5	Fixing	13
8.2.2.6	Access	14
8.2.2.7	Electrical installation requirements	14
8.2.2.8	Handling and storage	14
8.2.2.9	Sequence of work	14

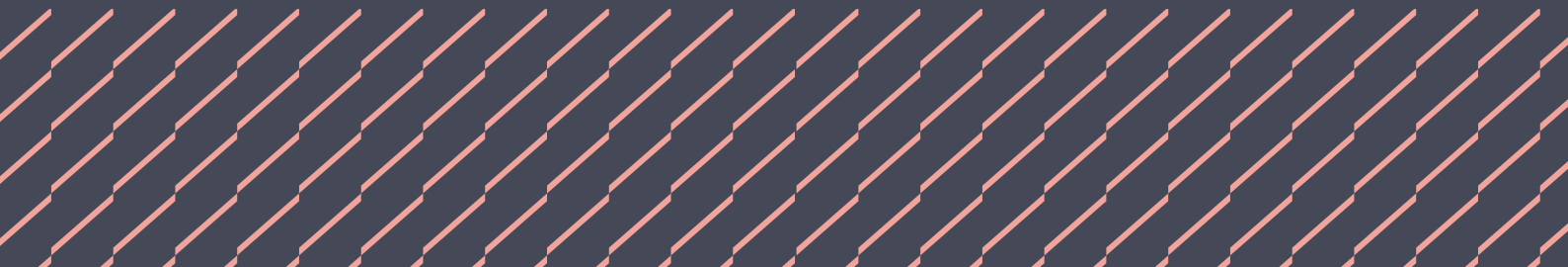

Figure reference table

Figure Reference Table 8.2.2

Fig No	Title/Description	Chapter	Page
Figure 1	Wind turbine schematic	8.2.2	10
Figure 2	Wind turbine schematic with battery	8.2.2	10

Figure 1: Wind turbine schematic

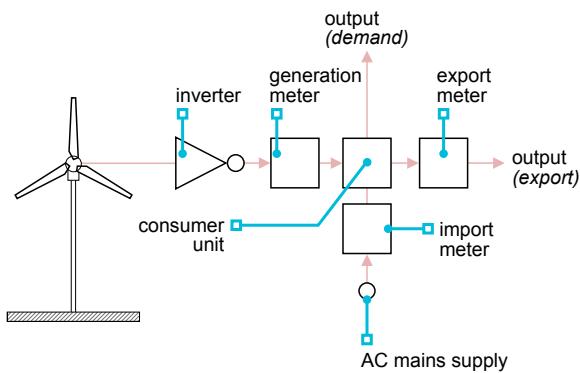
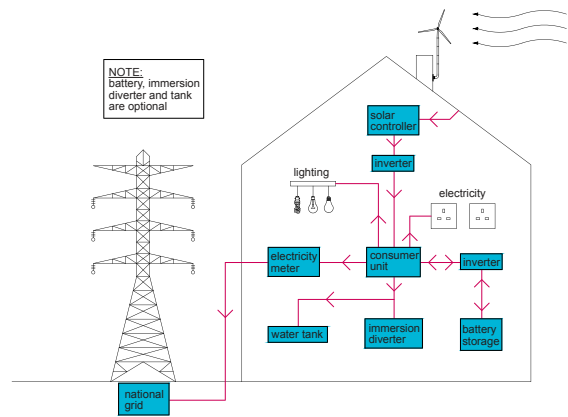

Figure 2: Wind turbine schematic with battery



Definitions for wind turbines

Coastal locations	A site within a distance of 500m from the general coastline of the United Kingdom.
Controls	Used to operate and/or regulate the system, and may be electrical or mechanical.
Exclusion zone	An area where entry is restricted during periods when maintenance is in progress, to prevent risk of injury or loss of life.
Inverter	A device that converts direct current into alternating current.
Islanding (island mode operation)	Where an LZC technology feeds the network or local distribution system during a planned or unscheduled loss of mains supply.
Low or zero carbon (LZC) technologies	A term applied to renewable sources of energy, and also to technologies which are significantly more efficient than traditional solutions, or which emit less carbon in providing heating, cooling or power.
Parallel electrical generation	A system in which building loads can be fed simultaneously from the national grid or electricity supply grid and on-site sources such as wind turbines and PV panels.
Performance	The manner or quality of functioning for a material, product or system.
Renewable energy	Energy from naturally available sources that can be replenished, including energy from the sun, wind and tides, and from replaceable matter such as wood or other plant material.
Switchgear	The combination of electrical switches, fuses and/or circuit breakers used to isolate electrical equipment.

8.2.2.1 Compliance

Also see: Chapter 2.1

Wind turbines shall comply with the Technical Requirements, and shall be securely fixed and not adversely affect the weather resistance of the building. Issues to be taken into account include:

- 1) relevant standards
- 2) product certification
- 3) operative competency.

8.2.2.1.1 Relevant standards

Wind turbines should comply with relevant standards, including, where applicable:

BS EN 61400-1	Wind turbines — Design requirements
BS EN 61400-2	Wind turbines — Small wind turbines
BS EN 61400-11	Wind turbines — Acoustic noise measurement techniques
BS EN 61400-12	Power performance measurements of electricity producing wind turbines
BS EN 60068	Environmental testing
BS EN IEC 62108	Requirements for assessing the products capacity for long term operation in general open-air climates
MIS 3003	Requirements for MCS Contractors Undertaking the Supply, Design, Installation, Set to Work, Commissioning and Handover of Micro and Small Wind Turbine Systems
MCS 006	Micro and small wind turbines

8.2.2.1.2 Product certification

Wind turbine technologies should have current certification confirming satisfactory assessment by an appropriate independent authority acceptable to NHBC.

Systems, products and installations that are assessed through the Microgeneration Certification Scheme (MCS) will generally be acceptable to NHBC. Certification and test documentation should be made available to NHBC upon request.

Other certification bodies or test documentation may be acceptable where they are considered by NHBC to be a suitable alternative.

8.2.2.1.3 Operative competency

Wind turbine systems should be installed by companies, organisations or operatives who are:

- competent and familiar with the system being installed, and
- certified to a standard acceptable to NHBC.
- MCS Certified, or

8.2.2.2 Provision of information

Designs and specifications shall be produced in a clearly understandable format, include all relevant information and be distributed to the appropriate personnel.

Provision of information is important as it allows for energy-efficient use of the building and common methods adopted to prevent overheating.

Clear and fully detailed drawings should be available on site to enable work to be carried out in accordance with the design. Designs and specifications should be issued to site supervisors, relevant specialist subcontractors and suppliers, and include the following information:

- fixing schedule
- a full set of current drawings
- indication of which manufacturer and/or installer is responsible for each system and interface
- commissioning schedule
- manufacturers' specifications
- interface details
- on-site testing requirements
- type and spacing of clips and fixings
- type and location of ancillary components, including those used for fire safety and acoustic purposes
- commissioning certificates
- wind load calculations
- snow load calculations.

8.2.2.3 System design

Wind turbine systems shall be designed to ensure satisfactory performance. Issues to be taken into account include:

- 1) location
- 2) system
- 3) compatibility
- 4) performance
- 5) diverters
- 6) battery and storage
- 7) acoustics.

8.2.2.3.1 Location

Wind turbine systems, including ancillary equipment, should be correctly located and:

- installed in accordance with the manufacturer's instructions and MIS 3003
- not be obstructed to prevent incorrect and efficient operation
- for stand-alone wind turbine systems, suitable exclusion zones provided in accordance with the manufacturer's recommendations and geographical location.

The design and location of wind turbine technologies should take account of factors such as coastal location.

When installed in a coastal location, fixings and bracketry should be appropriate for the area, and stainless steel grade 316 should be used where appropriate.

8.2.2.3.2 System

Wind turbine systems should be designed in accordance with the manufacturer's recommendations, certification scheme requirements and appropriate standards.

Each system should generally be supplied from one manufacturer as a package, not as individual components or materials. However, where components from more than one manufacturer are used, they should be compatible to ensure satisfactory performance.

8.2.2.3.3 Compatibility

Wind turbine systems should be installed so as not to adversely affect the performance of the building to which they are fixed, and in accordance with the manufacturer's recommendations.

Multiple systems should be compatible with each other.

8.2.2.3.4 Performance

Wind turbine systems designed to contribute towards water heating should be designed in accordance with the performance requirements in Clause 8.1.8.

8.2.2.3.5 Diverters

The provision of immersion diverters is discretionary. Where used, they should be designed by a competent person to prevent any adverse operation to the installed electrical installation, either upstream or downstream, including RCD and islanding protection.

8.2.2.3.6 Batteries and storage

Also see: Clause: 8.1.6

The provision of battery storage is discretionary. Where used, they should be designed by a competent person and in conjunction with the IET Code of Practice for Electrical Energy Storage Systems and BS 7671 18th Edition wiring regulations, and:

- the installation should be in line with MIS 3012 and manufacturer's installation instructions
- the inverters must be fully type tested to the standards required by the Energy Networks Association recommendations
- the batteries and storage equipment should not be located where they are at risk of accidental damage or where their enclosures are not designed for
- batteries intended for use in dwellings should be housed in a suitable enclosure meeting the relevant IPX rating
- batteries/storage should not be placed so that escape routes are impeded, and that any fire in the battery does not compromise protected escape routes
- where batteries are located, have sufficient ventilation to prevent overheating and prevent explosive conditions of evolved gasses
- should not be designed and installed where foreseeable flood or water inundation conditions may occur.

Further guidance relating to battery installation can be found in PAS 63100 Electrical installations — Protection against fire of battery energy storage systems for use in dwellings.

8.2.2.3.7 Acoustics

Design and location should take account of:

- internal and external noise
- vibration
- the effect on neighbouring properties, particularly the positioning of the wind turbine system in relation to openings.

8.2.2.4 Building integration*Also see: Chapter 8.6*

Wind turbine systems shall be securely fixed and not adversely affect the weather resistance of the building.

Foundations and anchor points for stand-alone LZC technologies should be designed by an engineer in accordance with Technical Requirement R5 to withstand the structural forces acting upon them.

The structure to which the LZC technology is attached should be assessed according to its ability to accept the loadings and prevent detrimental effects arising from movement or vibration.

The design of the structure should take account of:

- the self-weight of the LZC components
- imposed loads
- wind loads
- snow loads
- dynamic loading (where relevant).

Notching, drilling or chasing of structural components to accommodate service pipes or cables should either comply with Chapter 8.6 Installation and commissioning or be designed by an engineer in accordance with Technical Requirement R5.

Fixings, supports, bracketry and mounting frames should:

- accommodate all static and dynamic loads in accordance with the manufacturer's recommendations
- have adequate protection against corrosion (grade 316 stainless steel is recommended for coastal locations)
- be compatible or isolated where two metals are to be joined to prevent bimetallic corrosion.

Aluminium and aluminium alloys should not come into contact with cementitious material.

All interfaces between the LZC technology and the building should ensure adequate weather resistance, and be sealed to limit air leakage and prevent moisture from reaching the interior or any part of the structure that could be adversely affected by its presence. The envelope should be weatherproofed using appropriate flashings and fixings. Weatherproofing details that rely solely on sealant are not acceptable.

8.2.2.5 Fixing*Also see: Chapter 2.1*

Wind turbine systems shall be fixed using durable materials.

Fixings should comply with the types listed in Table 1.

Table 1: Materials suitable for fixings

Fixing material	Guidance
Phosphor bronze	NA
Silicon bronze	NA
Stainless steel	BS EN ISO 3506
Mild steel	Coatings to BS EN ISO 2081, BS EN ISO 2082, BS EN 1461 or other appropriate treatment in accordance with BS EN ISO 12944 or BS EN ISO 14713
Aluminum alloy	BS EN 573 and BS EN 755
Stainless steel	BS EN 10088
Mild steel	BS EN 10346
Other materials	Assessed in accordance with Technical Requirement R3

Materials that comply with recognised standards, which provide equal performance to (or better than) those above, are also acceptable.

The type, size, number, position and fitting tolerance of fixings should be in accordance with the manufacturer's recommendations.

Issues that should be taken into account include:

- the provision of suitable locking nuts and washers
- the isolation of aluminium from cementitious material.
- the isolation of dissimilar metals

8.2.2.6 Access

Appropriate arrangements shall be provided for the purposes of cleaning, inspection, maintenance and repair or replacement of wind turbine systems.

Safe access should be provided to the wind turbine systems, including switchgear, inverters, meters and controls. This is to enable the cleaning, inspection, maintenance and repair of systems. Access should be provided in accordance with the manufacturer's recommendations.

8.2.2.7 Electrical installation requirements

Also see: Clause: 8.1.6

The electrical installation shall be in accordance with relevant regulations.

Electrical installations should comply with BS 7671 Requirements for Electrical Installations.

Where parallel electrical generation occurs, inverters should have a relevant Engineering Recommendation G83/2 type test certificate and comply with all other parts of ER G83/2 for standard installations. Larger installations should comply with ER G59/3-2.

The electrical installation should be capable of being isolated from all other electrical sources when required, for maintenance or testing.

Wind turbine systems which generate electricity and are connected to the mains should automatically disconnect when there is a mains power failure. This is to prevent them from feeding the network or local distribution system during a planned or unscheduled loss of mains supply. This is known as 'islanding'.

Lightning protection must be installed as directed by the equipment manufacturer.

8.2.2.8 Handling and storage

Materials, products and systems shall be handled, stored and protected in a satisfactory manner to prevent damage, distortion, weathering and degradation.

Wind turbine systems should be:

- transported, lifted, handled and stored in accordance with the manufacturer's recommendations
- delivered in sequence to avoid storage
- protected to avoid the risk of damage.

8.2.2.9 Sequence of work

Wind turbine systems shall be installed in accordance with a suitable schedule.

To ensure performance, wind turbine systems and ancillary components should be installed in a logical and timely sequence in accordance with the manufacturer's recommendations.



Chapter 8.3



Space heating systems

This chapter provides guidance for space heating design and equipment that provide heating solutions, including low or zero carbon sources (LZC). Other LZC systems that follow the general principles of this chapter may also be acceptable, subject to specific agreement with NHBC.

This chapter contains the following sections:

- 8.3.1 Space heating
 - 8.3.2 Gas heating appliances
 - 8.3.3 Heat pumps
 - 8.3.4 Biomass
- 



Chapter

8.3.1



NHBC

Space heating

Space heating relates to the design of home heating to achieve comfort conditions.

8.3.1.1 Requirements

01



8.3.1.1 Requirements

Also see: Chapter 2.1

When space heating is provided, it shall comply with the Technical Requirements and ensure safe operation. Issues to be taken into account include:

- 1) relevant standards
- 2) space heating provision.

8.3.1.1.1 Relevant standards

Relevant standards for space heating design used in domestic hydronic systems include:

BS 5410	Code of practice for oil firing
BS EN 14336	Heating systems in buildings. Installation and commissioning of water based heating systems
BS 8303	Installation of domestic heating and cooking appliances burning solid mineral fuels
BS EN 12828	Heating systems in buildings. Design for water-based heating systems
BSRIA guide BG 4/2011	Underfloor Heating and cooling
CIBSE guide A	Environmental design
CIBSE	HVDH Domestic heating design guide

Space heating and cooling appliances, including all components and controls, should be of a type approved by the relevant authority, including:

- gas appliances — assessment by an appropriate independent technical approvals authority accepted by NHBC confirming compliance with UK CA, UK NI or CE marking
- solid fuel — Solid Fuel Association, Heating Equipment Testing and Approval Scheme
- electricity — British Electrotechnical Approvals Board
- oil — OFTEC
- LZC technologies — should have a current certificate confirming satisfactory assessment by an appropriate independent authority acceptable to NHBC (systems, products and installations assessed through Microgeneration Certification Scheme (MCS) will generally be acceptable to NHBC)
- certification and test documentation should be made available to NHBC upon request
- other certification bodies or test documentation may be acceptable where they are considered by NHBC to be a suitable alternative.

8.3.1.1.2 Space heating provision

The provision of whole home or central heating is discretionary. Where provided by infrared radiant panels, the system should be designed by a specialist and recognised standards. Where provided by hydronic systems or convector panel heaters, it should be designed in accordance with Tables 1, 2 and 3, recognised standards and:

- the number of air changes per hour from kitchens and bathrooms should account for any mechanical ventilation
- where rooms contain open flued appliances, the rate of air change used for the design should be increased in accordance with BS EN 12831
- room ventilation rates should be in accordance with recognised standards and guidance eg CIBSE HVDH Domestic heating design guide or other approved by NHBC (see Table 1)
- design temperatures should be verified by calculations and not by performance tests
- the main living room should have a heating appliance or a heat output as part of a whole home heating system
- heat loss calculations should be based on external temperature in line with Tables 2 and 3
- the heating designs must include allowances, where applicable, for thermal bridging
- the design may need to use elevated temperatures to take into account the frail, elderly or infirm.

Table 1: Air change rates per hour (CIBSE HVDH Domestic heating design guide)

Room	ACH	Room	ACH	Room	ACH
Lounge/sitting room	0.5	Cloakroom/WC	1.5*	Internal room/corridor	0.0
Living room	0.5	Toilet	1.5*	Bedroom/study	0.5
Breakfast room	0.5	Utility room	0.5*	Landing	0.5
Dining room	0.5	Study	0.5	Bathroom	0.5*
Kitchen	0.5*	Games room	0.5	Shower room	0.5*
Family/breakfast room	0.5*	Bedroom	0.5	Dressing room	0.5
Hall	0.5	Bedroom with ensuite	1.0	Storeroom	0.5

* Where mechanical extract ventilation is to be installed, and the value exceeds the natural infiltration, due allowance must be made for the air extracted from any connecting room or corridor as detailed in Approved Document F.

Table 2: Room temperatures, new build insulated to current standards

Room	Temp °C	Room	Temp °C	Room	Temp °C
Lounge/sitting room	21	Cloakroom/WC	21	Internal room or corridor	21
Living room	21	Toilet	21	Bedroom/study	21
Breakfast room	21	Utility room	21	Landing	21
Dining room	21	Study	21	Bathroom	22
Kitchen	21	Games room	21	Shower room	22
Family/breakfast room	21	Bedroom	21	Dressing room	21
Hall	21	Bedroom with en suite	21	Storeroom	21

Table 3: Outdoor design temperatures

Region	Latitude	Outdoor design temperature °C	Ground reference temperature (winter mean °C)
Scotland and Isles	56-60°N	-5	+5.5
Northern England and Northern Ireland	54-56°N	-4	+6.0
Midlands, Wales and ROI	52-54°N	-3	+6.5
London, SW England	51-52°N	-2	+7.0
Southern England	50-51°N	-1	+7.5



Chapter

8.3.2



Gas heating appliances

Appliances using natural gas or LPG to provide space heating and water to a dwelling.

8.3.2.1	Compliance	05
8.3.2.2	Provision of information	05
8.3.2.3	System design	06
8.3.2.4	Building integration	06
8.3.2.5	Fixing	07
8.3.2.6	Access	07
8.3.2.7	Electrical installation requirements	07
8.3.2.8	Handling and storage	07
8.3.2.9	Sequence of work	07

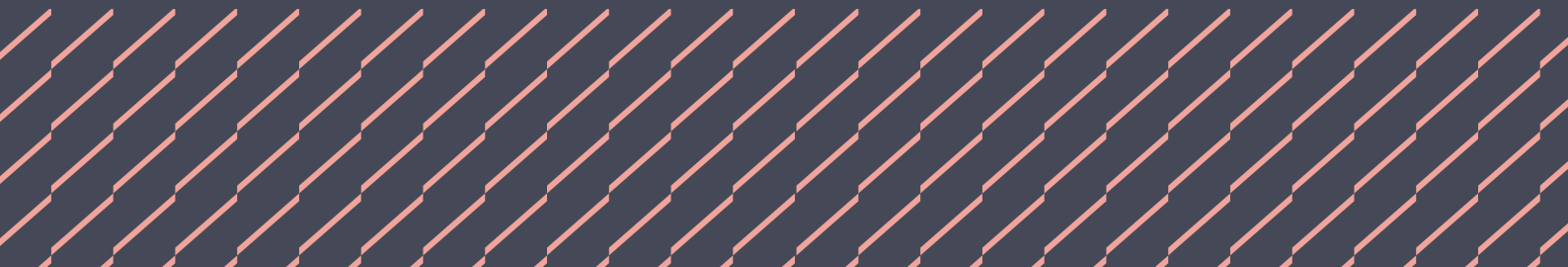

8.3.2.1 Compliance

Also see: Chapter 2.1

Gas heating appliances shall comply with the Technical Requirements. Issues to be taken into account include:

- 1) relevant standards
- 2) product certification
- 3) operative competency.

8.3.2.1.1 Relevant standards

Gas heating appliances should comply with relevant standards including where applicable:

BS 6798	Specification for selection, installation, inspection, commissioning, servicing and maintenance of gas-fired boilers of rated input not exceeding 70kW net
BS 5440-1	Flueing and ventilation for gas appliances of rated input not exceeding 70kW — flueing
BS 5440-2	Flueing and ventilation for gas appliances of rated input not exceeding 70kW — ventilation

8.3.2.1.2 Product certification

Gas heating appliances should hold a current assessment by an appropriate independent technical approvals authority accepted by NHBC confirming compliance with UK CA, UK NI or CE marking. A Declaration of Conformity detailing the standards the product complies with and documents should be available on request.

8.3.2.1.3 Operative competency

Gas heating appliances and associated equipment shall be installed by competent operatives who are:

- familiar with the system being installed, and
- members of a class of persons approved by the HSE (Gas Safe registered).

8.3.2.2 Provision of information

Designs and specifications shall be produced in a clearly understandable format, include all relevant information and be distributed to the appropriate personnel.

Provision of information is important as it allows for energy-efficient use of the building and common methods adopted to prevent overheating.

Clear and fully detailed drawings should be available on site to enable work to be carried out in accordance with the design. Design and specification information should be issued to site supervisors, relevant specialist subcontractors and suppliers, and include the following information:

- fixing schedule
- a full set of current drawings
- indication of which manufacturer and/or installer is responsible for each system and interface
- commissioning schedule
- manufacturers' specifications
- interface details
- on-site testing requirements
- type and spacing of clips and fixings
- type and location of ancillary components, including those used for fire safety and acoustic purposes
- commissioning certificates
- central heating pipe runs
- underfloor heating pipe runs
- specification for controls.

8.3.2.3 System design

Gas heating systems shall be designed to ensure satisfactory performance. Issues to be taken into account include:

- | | |
|------------------|----------------|
| 1) location | 4) performance |
| 2) system | 5) acoustics. |
| 3) compatibility | |

8.3.2.3.1 Location

Gas heating appliances, including ancillary components, should be located and identified in accordance with the manufacturer's recommendations. Consideration should be given to:

- coastal locations see Clause 8.2.1 definitions
- height of building and flue materials.

8.3.2.3.2 System

Gas heating systems should be designed in accordance with the manufacturer's recommendations and appropriate standards.

Each system incorporating a flue should generally be supplied from one manufacturer as a package, not as individual components or materials. However, where components from more than one manufacturer are used, they should be compatible to ensure satisfactory performance.

8.3.2.3.3 Compatibility

Gas heating systems should be installed so as not to adversely affect the performance of the building to which they are fixed, and in accordance with the manufacturer's recommendations.

8.3.2.3.4 Performance

Gas heating systems designed to contribute towards space and water heating should be designed in accordance with the performance requirements in Chapters 8.4 Ventilation and 8.6 Installation and commissioning.

8.3.2.3.5 Acoustics

Design and location should take account of:

- internal and external noise
- vibration.

8.3.2.4 Building integration

Also see: Chapter 8.6

Gas heating appliance systems installation shall be securely fixed and not adversely affect the weather resistance of the building.

Notching, drilling or chasing of structural components to accommodate service pipes or cables should either comply with Clause 8.6.2 or be designed by an engineer in accordance with Technical Requirement R5.

Fixings, supports, bracketry and mounting frames should:

- accommodate all static and dynamic loads in accordance with the manufacturer's recommendations
- be compatible or isolated where two metals are to be joined to prevent bimetallic corrosion.
- have adequate protection against corrosion (grade 316 stainless steel is recommended for coastal locations)

Aluminium and aluminium alloys should not come into contact with cementitious material.

All interfaces between the building and equipment should ensure adequate weather resistance, and be sealed to limit air leakage and prevent moisture from reaching the interior or any part of the structure that could be adversely affected by its presence. The envelope should be weatherproofed using appropriate flashings and fixings. Weatherproofing details that rely solely on sealant are not acceptable.

8.3.2.5 Fixing

Also see: Chapter 2.1

Gas heating systems shall be securely fixed using durable materials.

Fixings should comply with the types listed in Table 1.

Table 1: Materials suitable for fixings

Fixing material	Guidance
Phosphor bronze	NA
Silicon bronze	NA
Stainless steel	BS EN ISO 3506
Mild steel	Coatings to BS EN ISO 2081, BS EN ISO 2082, BS EN 1461 or other appropriate treatment in accordance with BS EN ISO 12944 or BS EN ISO 14713
Aluminum alloy	BS EN 573 and BS EN 755
Stainless steel	BS EN 10088
Mild steel	BS EN 10346
Other materials	Assessed in accordance with Technical Requirement R3

Materials that comply with recognised standards, which provide equal performance to (or better than) those above, are also acceptable.

The type, size, number, position and fitting tolerance of fixings should be in accordance with the manufacturer's recommendations.

Issues that should be taken into account include:

- the provision of suitable locking nuts and washers
- the isolation of aluminium from cementitious material.
- the isolation of dissimilar metals

8.3.2.6 Access

Appropriate arrangements shall be provided for the purposes of cleaning, inspection, maintenance and repair or replacement of gas heating systems.

Safe access should be provided to systems to enable the cleaning, inspection, maintenance and repair or replacement. Access should be provided in accordance with the manufacturer's recommendations.

For installation in a loft or roof void, guidance is provided in Clause 7.2.12.

8.3.2.7 Electrical installation requirements

Also see: Clause: 8.1.6

The electrical installation shall be in accordance with relevant regulations.

Electrical installations should comply with BS 7671 Requirements for Electrical Installations.

The electrical installation should be capable of being isolated from all other electrical sources when required, for maintenance or testing. An unswitched shuttered socket or double pole fused spur with 3.5mm separation will generally be acceptable.

8.3.2.8 Handling and storage

Materials, products and systems shall be handled, stored and protected in a satisfactory manner to prevent damage, distortion, weathering and degradation.

Gas heating systems should be:

- transported, lifted, handled and stored in accordance with the manufacturer's recommendations
- delivered in sequence to avoid storage
- protected to avoid the risk of damage.

8.3.2.9 Sequence of work

Gas heating systems shall be installed in accordance with a suitable schedule.

To ensure performance, gas heating systems and ancillary components should be installed in a logical and timely sequence in accordance with the manufacturer's recommendations.



Chapter

8.3.3



Heat pumps

Systems which transfer heat from low energy sources.

8.3.3.1	Compliance	11
8.3.3.2	Provision of information	12
8.3.3.3	System design	12
8.3.3.4	Pipes, insulation and protection from cold	13
8.3.3.5	Ground collectors	14
8.3.3.6	Building integration	14
8.3.3.7	Fixing	14
8.3.3.8	Access	15
8.3.3.9	Electrical installation requirements	15
8.3.3.10	Handling and storage	15
8.3.3.11	Sequence of work	15

Figure reference table

Figure Reference Table 8.3.3

Fig No	Title/Description	Chapter	Page
Figure 1	Heat pump schematic	8.3.3	10
Figure 2	Air source heat pump	8.3.3	10
Figure 3	Ground source heat pump	8.3.3	10
Figure 4	Alternative heat sources (boreholes and ground collectors)	8.3.3	10

The most common sources are ground, outdoor air and exhaust air (see Figures 1 to 4).

Figure 1: Heat pump schematic

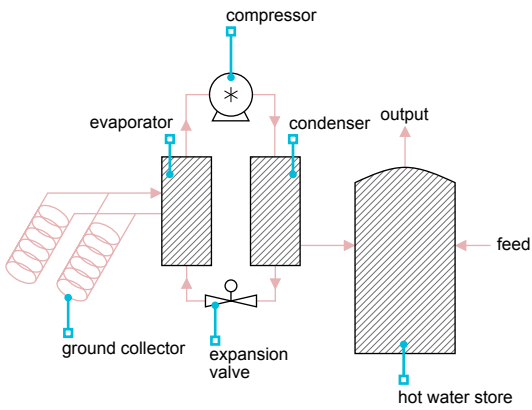

Figure 2: Air source heat pump

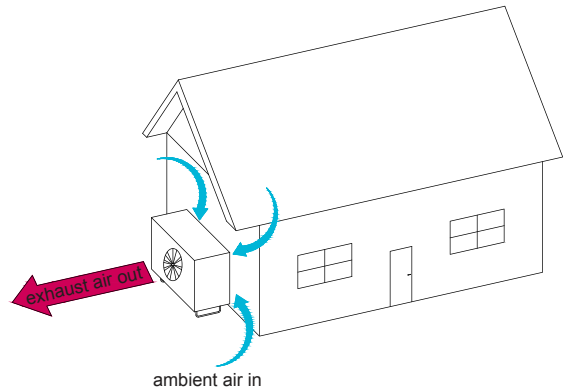

Figure 3: Ground source heat pump

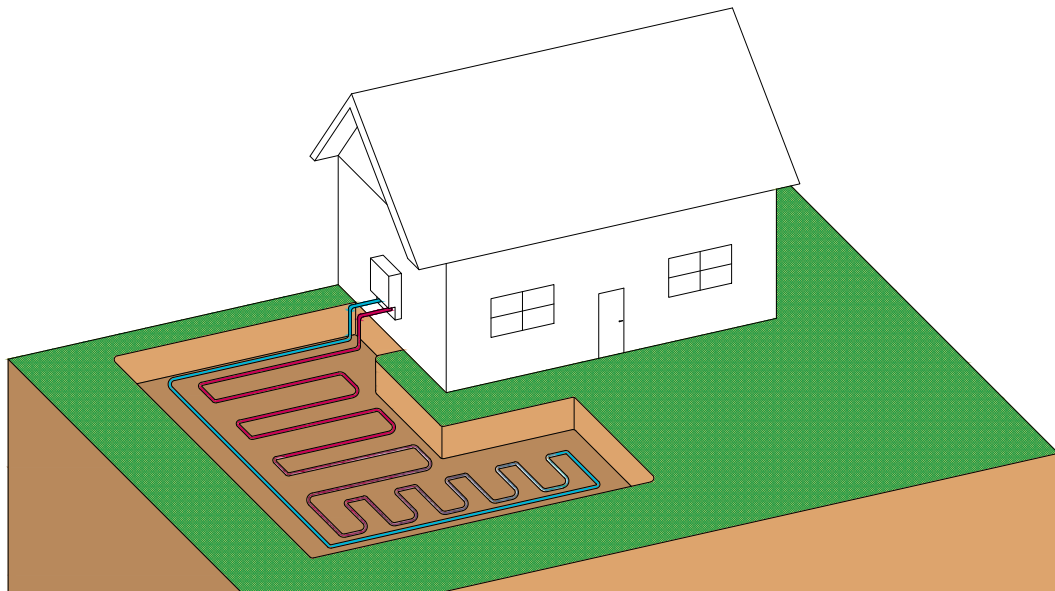
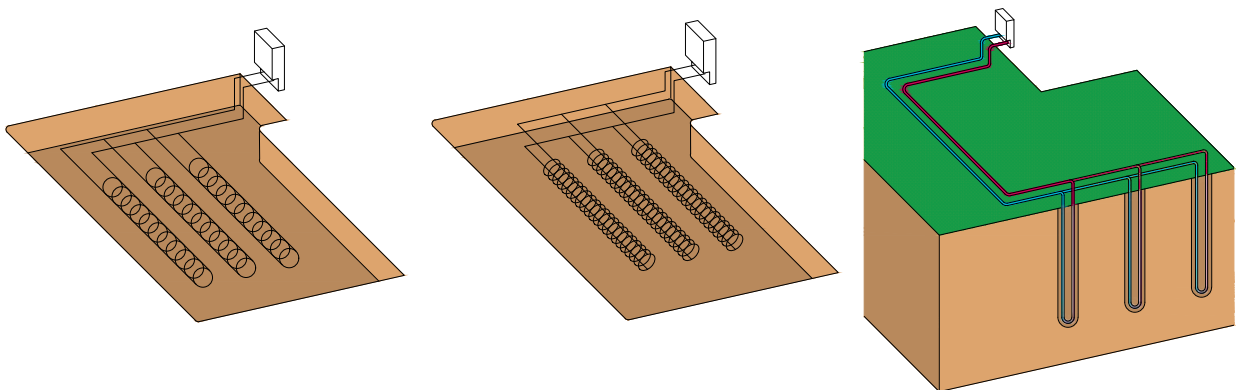

Figure 4: Alternative heat sources (boreholes and ground collectors)



Definitions for heat pumps

Coastal locations	A site within a distance of 500m from the general coastline of the United Kingdom.
Controls	Used to operate and/or regulate the system, and may be electrical or mechanical.
Exclusion zone	An area where entry is restricted during periods when maintenance is in progress, to prevent risk of injury or loss of life.
Exhaust air heat pump	A subset of air-source heat pumps, typically combined with mechanical ventilation to extract and reuse heat from the exhaust air.
Ground collectors	The component of a ground source heat pump system which absorbs heat from the ground. Collectors can be installed either horizontally or vertically in the ground. They may also be incorporated into proprietary foundation systems.
Low or zero carbon (LZC) technologies	A term applied to renewable sources of energy, and also to technologies which are significantly more efficient than traditional solutions, or which emit less carbon in providing heating, cooling or power.
Monobloc heat pump	A type of heat pump in which all of its components are in one unit; in the case of air-source heat pumps, this will usually be located outside the dwelling.
Open loop system	A heat pump system that extracts water from an underground source, pumps it through a heat exchanger and returns it underground.
Performance	The manner or quality of functioning for a material, product or system.
Refrigerant pipework	Carries refrigerant between the indoor and outdoor unit of a split system; normally made of copper and must be insulated and protected from damage.
Renewable energy	Energy from naturally available sources that can be replenished, including energy from the sun, wind and tides, and from replaceable matter such as wood or other plant material.
Split system heat pump	A type of heat pump in which the condenser is located indoors, the evaporator is located outdoors, and the two are linked by refrigerant pipework.
Switchgear	The combination of electrical switches, fuses and/or circuit breakers used to isolate electrical equipment.

8.3.3.1 Compliance

Also see: Chapter 2.1

Heat pumps shall comply with the Technical Requirements. Issues to be taken into account include:

- 1) relevant standards
- 2) product certification
- 3) operative competency.

8.3.3.1.1 Relevant standards

Heat pumps should comply with relevant standards, including, where applicable:

BS EN 14511-1	Air conditioners, liquid chilling packages and heat pumps for space heating and cooling with electrically driven compressors for space heating and cooling. Terms and definitions
BS EN 14511-2	Air conditioners, liquid chilling packages and heat pumps for space heating and cooling with electrically driven compressors for space heating and cooling. Test conditions
BS EN 14511-3	Air conditioners, liquid chilling packages and heat pumps for space heating and cooling with electrically driven compressors for space heating and cooling. Test methods
BS EN 14511-4	Air conditioners, liquid chilling packages and heat pumps for space heating and cooling with electrically driven compressors for space heating and cooling. Requirements
BS EN 16147	Heat pumps with electrically driven compressors requirements for domestic hot water
BS EN 12102-1	Determining the sound power level of compressors
BS EN 14825	Calculation of seasonal performance
BS EN IEC 62108	Requirements for assessing the products capacity for long term operation in general open-air climates
MIS 3005-D	Microgeneration Certification Scheme requirements for the supply, design of heat pump systems
MIS 3005-I	Microgeneration Installation Standard for heat pumps installation
Fluorinated gas (F gas)	Guidance for users, producers and traders
MCS CC 002	Micro generation heat pump compliance certificate commissioning standard
MCS 007	Heat pump standard

8.3.3.1.2 Product certification

Heat pump technologies should have current certification confirming satisfactory assessment by an appropriate independent authority acceptable to NHBC.

Products that are certified through the Microgeneration Certification Scheme (MCS) will generally be acceptable to NHBC. Certification and test documentation should be made available to NHBC upon request.

Other certification bodies or test documentation may be acceptable where they are considered by NHBC to be a suitable alternative.

8.3.3.1.3 Operative competency

Heat pump systems should be installed by companies, organisations or operatives who are:

- competent and familiar with the system being installed, and
- certified to a standard acceptable to NHBC.
- MCS Certified, or

Where installers are not certified by MCS the operative should still hold the relevant qualifications such as:

- completed an approved British Plumbing Employers Council (BPEC) training course for heat pump systems and low temperature hot water heating systems
- electrically qualified
- F gas registered where required
- registered to install unvented cylinders.

8.3.3.2 Provision of information

Designs and specifications shall be produced in a clearly understandable format, include all relevant information and be distributed to the appropriate personnel.

Provision of information is important as it allows for energy-efficient use of the building and common methods adopted to prevent overheating.

Clear and fully detailed drawings should be available on site to enable work to be carried out in accordance with the design. Design and specification information should be issued to site supervisors, relevant specialist subcontractors and suppliers, and include the following information:

- fixing schedule
- a full set of current drawings
- indication of which manufacturer and/or installer is responsible for each system and interface
- commissioning schedule
- manufacturers' specifications
- interface details
- on-site testing requirements
- type and spacing of clips and fixings
- type and location of ancillary components, including those used for fire safety and acoustic purposes
- commissioning certificates
- central heating pipe runs
- underfloor heating pipe runs
- specification for controls.

8.3.3.3 System design

Also see: Chapter 8.3.1

Heat pumps systems shall be designed to ensure satisfactory performance. Issues to be taken into account include:

- 1) location
- 2) system design
- 3) compatibility
- 4) performance
- 5) acoustics.

8.3.3.3.1 Location

Heat pumps, including ancillary components, should be located and identified in accordance with the manufacturer's recommendations.

Heat pumps, when sited in coastal locations, should be suitable for the environment. Manufacturers' recommendations should be followed detailing maintenance requirements, or any ancillary coatings that are acceptable if not factory treated, to prolong the life of the heat pump.

8.3.3.3.2 System design

Heat pump systems should be designed in accordance with the manufacturer's recommendations, certification scheme requirements and appropriate standards.

Each system should generally be supplied from one manufacturer as a package, not as individual components or materials. However, where components from more than one manufacturer are used, they should be compatible to ensure satisfactory performance.

The heat pump selected should provide not less than 100% of the calculated design space heating power requirement at the winter design condition and include any energy required for defrost cycles. Any supplementary electric heating shall only operate when the conditions are outside of the standards.

- all heat loss calculations should be in accordance with recognised standards and guidance, eg CIBSE HVDH Domestic heating design guide or other approved by NHBC
- fabric heat loss calculations should be based on the building design and thermal conductivity of the materials from which the element is constructed
- the heating designs must include allowances where applicable for thermal bridging
- design mean water temperature (MWT) of 42.5°C, the design can use an MWT lower than this
- the number and sizing of heat emitters eg radiators or size of underfloor system, must be sized to the design MWT
- the system pipework or underfloor heating must be sized to the design MWT
- the heat pump must have a minimum coefficient of performance of 3.0 for space heating
- the heat pump must have a minimum seasonal coefficient of performance of 2.7
- the heat pump must control the pump operation
- the heat pump must control any outdoor fan operation
- the heat pump must control the defrost cycle for the external air side
- weather compensation or internal temperature control must be adopted with all heat pumps
- where the dwelling contains other heat sources, they should all be controlled from a singular control unit.

8.3.3.3.3 Compatibility

Heat pump systems should be installed so as not to adversely affect the performance of the building to which they are fixed, and in accordance with the manufacturer's recommendations.

Multiple systems should be compatible with each other.

8.3.3.3.4 Performance

Heat pump systems designed to contribute towards space and water heating should be designed in accordance with the performance requirements in Chapters 8.1 Internal services and 8.3 Space heating systems.

8.3.3.3.5 Acoustics

The design and location should take account of:

- internal and external noise
- vibration
- the effect on neighbouring properties, particularly the positioning of the heat pump in relation to openings.

8.3.3.4 Pipes, insulation and protection from cold

Also see: Chapter 8.6

All pipework and insulation, including refrigerant pipework, shall ensure adequate performance and be designed to prevent freezing.

Materials used for pipes and insulation should be suitable for the intended purpose and provide satisfactory performance for the life of the system. Pipes should comply with relevant codes and standards or be independently assessed for their intended use in accordance with Technical Requirement R3. Insulation materials should be inert, and durable, and should not be adversely affected by moisture or vapour. They should also comply with relevant codes and standards or be independently assessed for their intended use in accordance with Technical Requirement R3.

Where there is a risk of pipes freezing, they should be insulated, particularly when at, or close to, ground level.

Refrigerant pipework connecting split systems should be of refrigerant quality copper pipe or other material as recommended by the manufacturer. The pipe should be insulated, and the insulation should incorporate a vapour control layer to prevent ice build-up.

Air source systems should incorporate an automatic defrost cycle and suitable condensate drainage.

8.3.3.5 Ground collectors

The installation of ground collectors shall take structural and environmental factors into account.

The depth and layout of ground collectors should be specified to avoid freezing of adjacent ground. Where open loop systems are proposed, consultation with the appropriate environment agency should be made and may require one or more of the following:

- a licence to investigate groundwater
- an abstraction licence
- a discharge consent.

Excavations for the installation of ground collectors should not adversely affect aquifers, foundations, drainage, water supply pipes and other services. Design should take account of local planning authority guidance, including excavations that are close to trees and hedgerows.

Ground collectors should be protected and tested prior to backfilling.

8.3.3.6 Building integration

Also see: Chapter 8.6

Heat pump system installation shall be securely fixed and not adversely affect the weather resistance of the building.

Foundations and anchor points for stand-alone heat pump technologies should be designed by an engineer in accordance with Technical Requirement R5 to withstand the structural forces acting upon them.

The structure to which the heat pump technology is attached should be assessed according to its ability to accept the loadings and prevent detrimental effects arising from movement or vibration.

The design of the structure should take account of:

- the self-weight of the heat pump components
- imposed loads
- wind loads
- dynamic loading (where relevant).

Notching, drilling or chasing of structural components to accommodate service pipes or cables should either comply with Clause 8.6.2.7 or be designed by an engineer in accordance with Technical Requirement R5.

Fixings, supports, bracketry and mounting frames should:

- accommodate all static and dynamic loads in accordance with the manufacturer's recommendations
- have adequate protection against corrosion (grade 316 stainless steel is recommended for coastal locations)
- be compatible or isolated where two metals are to be joined to prevent bimetallic corrosion.

Aluminium and aluminium alloys should not come into contact with cementitious material.

All interfaces between the heat pump and the building should ensure adequate weather resistance, and be sealed to limit air leakage and prevent moisture from reaching the interior or any part of the structure that could be adversely affected by its presence. The envelope should be weatherproofed using appropriate flashings and fixings. Weatherproofing details that rely solely on sealant are not acceptable.

8.3.3.7 Fixing

Heat pump systems shall be securely fixed using durable materials.

Fixings should comply with the types listed in Table 1.

Table 1: Materials suitable for fixings

Fixing material	Guidance
Phosphor bronze	NA
Silicon bronze	NA
Stainless steel	BS EN ISO 3506
Mild steel	Coatings to BS EN ISO 2081, BS EN ISO 2082, BS EN 1461 or other appropriate treatment in accordance with BS EN ISO 12944 or BS EN ISO 14713
Aluminum alloy	BS EN 573 and BS EN 755
Stainless steel	BS EN 10088
Mild steel	BS EN 10346
Other materials	Assessed in accordance with Technical Requirement R3

Materials that comply with recognised standards, which provide equal performance to (or better than) those in Table 14, are also acceptable.

The type, size, number, position and fitting tolerance of fixings should be in accordance with the manufacturer's recommendations.

Issues that should be taken into account include:

- the provision of suitable locking nuts and washers
- the isolation of aluminium from cementitious material.
- the isolation of dissimilar metals

8.3.3.8 Access

Appropriate arrangements shall be provided for the purposes of cleaning, inspection, maintenance and repair or replacement of heat pump systems.

Safe access should be provided to the heat pump systems, including switchgear and controls. This is to enable the cleaning, inspection, maintenance and repair of systems. Access should be provided in accordance with the manufacturer's recommendations.

8.3.3.9 Electrical installation requirements

Also see: Clause: 8.1.6

The electrical installation shall be in accordance with relevant regulations.

Electrical installations should comply with BS 7671 Requirements for Electrical Installations.

The electrical installation should be capable of being isolated from all other electrical sources when required, for maintenance or testing.

Lightning protection must be installed as directed by the equipment manufacturer. Also see Clause 8.1.6.15.

8.3.3.10 Handling and storage

Materials, products and systems shall be handled, stored and protected in a satisfactory manner to prevent damage, distortion, weathering and degradation.

Heat pump systems should be:

- transported, lifted, handled and stored in accordance with the manufacturer's recommendations
- delivered in sequence to avoid storage
- protected to avoid the risk of damage.

8.3.3.11 Sequence of work

Heat pump systems shall be installed in accordance with a suitable schedule.

To ensure performance, heat pump systems and ancillary components should be installed in a logical and timely sequence in accordance with the manufacturer's recommendations.



Chapter

8.3.4



NHBC

Biomass

Systems which burn wood pellets or chips for space and/or water heating.

8.3.4.1	Compliance	18
8.3.4.2	Clean air act	19
8.3.4.3	Fuel storage	19

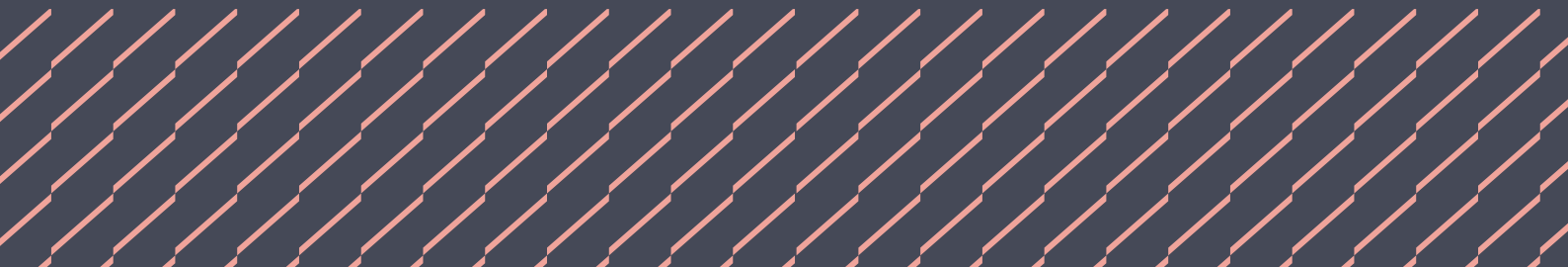
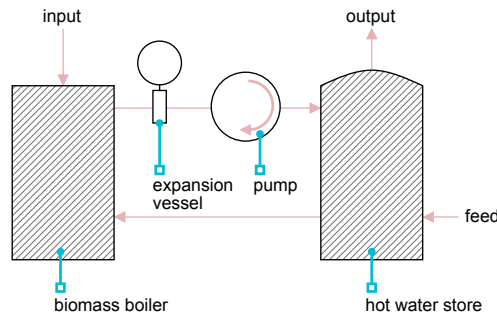

Figure reference table

Figure Reference Table 8.3.4

Fig No	Title/Description	Chapter	Page
Figure 1	Biomass schematic	8.3.4	18

Figure 1: Biomass schematic



8.3.4.1 Compliance

Also see: Chapter 2.1

Biomass systems shall comply with the Technical Requirements. Issues to be taken into account include:

- 1) relevant standards
- 2) product certification
- 3) operative competency.

8.3.4.1.1 Relevant standards

Biomass systems should comply with relevant standards, including, where applicable:

BS EN 303-5	Heating boilers — Heating boilers for solid fuels, manually and automatically stoked, nominal heat output of up to 500kW. Terminology, requirements, testing and marking
BS EN 12809	Residential independent boilers fired by solid fuel. Nominal heat output up to 50kW. Requirements and test methods
BS EN 13240	Roomheaters fired by solid fuel. Requirements and test methods
BS EN 14785	Residential space heating appliances fired by wood pellets. Requirements and test methods
MCS 008	Product Certification Scheme Requirements: Biomass
MGD 006	Percussive Events Guidance
MIS 3004	Requirements for MCS contractors undertaking the supply, design, installation commissioning and handover of solid biofuel heating systems
MCS CC 001	Biomass Compliance Certificate Template

8.3.4.1.2 Product certification

Biomass technologies should have current certification confirming satisfactory assessment by an appropriate independent authority acceptable to NHBC.

Systems, products and installations that are assessed through the Microgeneration Certification Scheme (MCS) will generally be acceptable to NHBC. Certification and test documentation should be made available to NHBC upon request.

Other certification bodies or test documentation may be acceptable where they are considered by NHBC to be a suitable alternative.

8.3.4.1.3 Operative competency

Biomass systems should be installed by operatives who are:

- competent and familiar with the system being installed, and
- certified to a standard acceptable to NHBC.
- MCS Certified, or

Where installers are not MCS accredited, they should still hold the relevant qualifications:

- HETAS qualified
- electrically qualified.

8.3.4.2 Clean air act

Biomass boilers installed in smoke controlled areas shall comply with relevant legislation.

Biomass boilers to be installed within a smoke controlled area should comply with the Clean Air Act 1993 or Clean Air (Northern Ireland) Order 1981. Installations also need to consider any local air quality management plans that are in effect and comply with the requirements.

8.3.4.3 Fuel storage

Also see: HVCA Guide to good practice: Installation of biofuel heating (TR/38)

Fuel storage for biomass boilers shall be suitable for the installation.

Fuel stores should have appropriate access for delivery.

- fire detection and extinguishing equipment where elevated dust levels are expected
- fire resistance and separation to prevent fire and gases entering other parts of the building.
- volume to take account of peak load and period of demand



Chapter

8.4



Ventilation

This chapter provides guidance for ventilation equipment, including low or zero carbon sources (LZC). Other LZC systems that follow the general principles of this chapter may also be acceptable, subject to specific agreement with NHBC.

This chapter contains the following sections:

- 8.4.1 Mechanical ventilation and heat recovery (MVHR) systems
- 8.4.2 Mechanical extract ventilation (MEV) systems

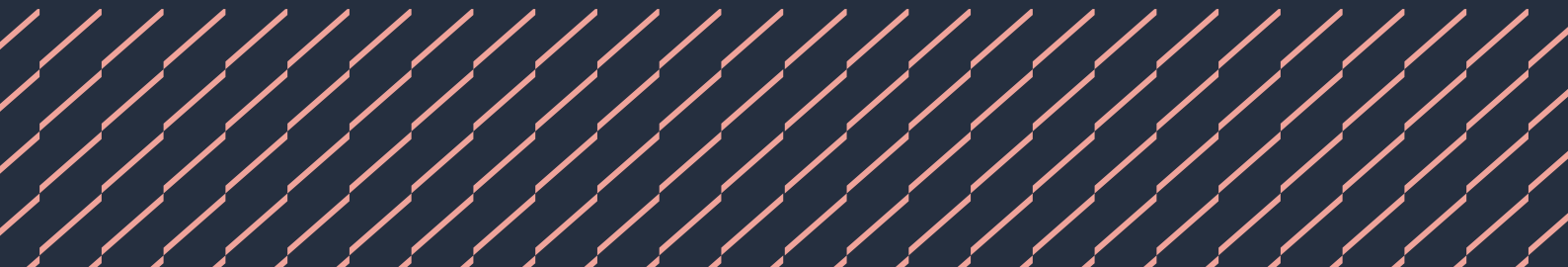

Mechanical ventilation and heat recovery (MVHR) systems

MVHR systems provide fresh filtered air into a building whilst retaining most of the energy that has already been used in heating the air within the building (see Figure 1 and 2).

8.4.1.1	Compliance	02
8.4.1.2	Provision of information	03
8.4.1.3	System design	03
8.4.1.4	Acoustics	05
8.4.1.5	Building integration	05
8.4.1.6	Ductwork	06
8.4.1.7	Fixing and jointing of ductwork	06
8.4.1.8	Access and operation	07
8.4.1.9	Electrical installation requirements	07
8.4.1.10	Handling and storage	07
8.4.1.11	Commissioning and balancing	08
8.4.1.12	Sequence of work	08



Figure reference table**Figure Reference Table 8.4.1**

Fig No	Title/Description	Chapter/Clause	Page
Figure 1	MVHR schematic	8.4.1	2
Figure 2	MVHR schematic layout	8.4.1	2
Figure 3	Protection from the cold	8.4.1.3.7	5
Figure 4	Air valve and ductwork	8.4.1.6	6

Figure 1: MVHR schematic

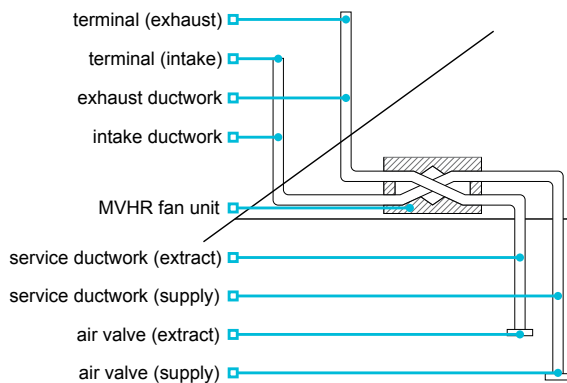
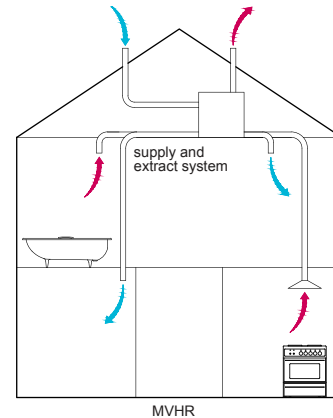

Figure 2: MVHR schematic layout



Definitions for MVHR

Air valve (extract and supply)	Wall or ceiling mounted fittings used to balance the flow rate of air between rooms; may be referred to as grilles or diffusers.
Exhaust ductwork	Carries air from the fan unit and exhausts it to the external atmosphere.
Intake ductwork	Carries air from the external atmosphere to the MVHR fan unit.
MVHR fan unit	Unit that contains the fan(s), heat exchanger and filter(s).
Service ductwork extract and supply	Carries air between the air valves and the MVHR fan unit.
Terminal fittings	Located on the outside of the building to finish the intake and exhaust ductwork.

8.4.1.1 Compliance

Also see: Chapter 2.1

MVHR systems shall comply with the Technical Requirements. Issues to be taken into account include:

- 1) relevant standards
- 2) product certification
- 3) operative competency.

8.4.1.1.1 Relevant standards

Relevant standards include:

BS 476	Fire tests on building materials and structures
BS EN 1365-2	Fire resistance tests for loadbearing elements. Floors and roofs
BS EN 1366-3	Fire resistance tests for service installations. Penetration seals
BS EN ISO 12001	Noise emitted by machinery and equipment
Approved Document F England	Ventilation
Scottish Technical Handbook	Section 3 Ventilation
Technical Booklet NI	Part K Ventilation

8.4.1.1.2 Product certification

MVHR appliances should hold a current assessment by an appropriate independent technical approvals authority accepted by NHBC confirming compliance with UKCA, UKNI or CE marking. A Declaration of Conformity detailing the standards the product complies with and documents should be available on request.

8.4.1.1.3 Operative competency

MVHR systems should be installed by competent operatives who are:

- familiar with the system being installed; installers who have been trained in accordance with the BPEC Ventilation Systems would generally be acceptable to NHBC, or
- certified to a standard acceptable to NHBC.

8.4.1.2 Provision of information

Designs and specifications shall be produced in a clearly understandable format, include all relevant information and be distributed to the appropriate personnel.

Provision of information is important as it allows for energy-efficient use of the building and common methods adopted to prevent overheating.

Clear and fully detailed drawings should be available on site to enable work to be carried out in accordance with the design. Design and specification information should be issued to site supervisors, relevant specialist subcontractors and suppliers, and include the following information:

- fixing schedule
- a full set of current drawings
- indication of which manufacturer and/or installer is responsible for each system and interface
- commissioning schedule
- manufacturers' specifications
- interface details
- on-site testing requirements
- type and spacing of clips and fixings
- type and location of ancillary components, including those used for fire safety and acoustic purposes
- commissioning certificates
- location of all ductwork runs, the fan unit and controls
- type, size and position of ducts and terminals
- direction of fall for horizontal ductwork
- designed airflow-balancing figures for the system
- thermal modelling.

8.4.1.3 System design

MVHR systems shall be in accordance with relevant Building Regulations and designed to minimise disturbance caused by noise. Issues to be taken into account include:

- 1) location
- 2) system
- 3) compatibility
- 4) performance
- 5) air valves and terminals
- 6) control of condensation
- 7) protection from the cold.

8.4.1.3.1 Location

MVHR systems should be correctly located, including ancillary components, and should be identified in accordance with the manufacturer's recommendations.

8.4.1.3.2 System

MVHR systems should be in accordance with relevant Building Regulations and installed to ensure that effective ventilation is provided without affecting health or creating unnecessary noise.

8.4.1.3.3 Compatibility

MVHR systems should be designed as a complete package, taking into account the performance of all components and materials, to ensure compatibility, and in accordance with the performance requirements of the system.

Particular consideration should be given where components from different manufacturers are specified on the same system.

8.4.1.3.4 Performance

MVHR systems should be designed to provide satisfactory performance and be installed according to the design and manufacturer's recommendations. Variations from the design should maintain the satisfactory performance of the system and be approved by the designer.

Issues that should be taken into account include:

- ventilation rates as set out in appropriate Building Regulations and standards
- fan capacity, accounting for airflow resistance of the system
- ensuring the even distribution of air flow, regulations, standards and airflow resistance, including from bends and fittings.

Airflow resistance should be calculated using figures for air valves and terminals determined in accordance with BS EN 13141-2 and data supplied by the duct manufacturer. Ductwork should be as direct as possible to reduce the number of bends.

Allowance should be made for air transfer within the home. Where gaps between the underside of internal doors and the floor finish are used for air transfer, the guidance in Chapter 9.1 A consistent approach to finishes should be considered.

8.4.1.3.5 Air valves and terminals

Air valves should be selected according to location and function, ensuring appropriate specification for:

- wall or ceiling location
- supply or extract function
- the velocity of the system.

To create cross ventilation within a room and to ensure satisfactory operation, air valves on low velocity systems should be:

- positioned on the opposite side of the room from internal door openings
- a minimum of 200mm from walls, where located on a ceiling
- a maximum of 400mm from the ceiling, located on a wall
- a minimum of 600mm (on plan) from hobs in kitchens
- positioned to account for the likely location of tall furniture and to avoid draughts over beds and seating areas
- lockable, where adjustable.

To prevent cross contamination, intake terminals should generally be separated from exhaust terminals and other potential sources of pollution by a minimum of 1m measured on plan. Increased separation distances may be required between the intake and any:

- soil and vent pipe terminal
- boiler flue outlet
- biomass or solid fuel chimney terminal.

Terminals should prevent the entry of birds and animals.

8.4.1.3.6 Control of condensation

Ductwork should be insulated to prevent condensation formation where:

- it passes through spaces outside the insulated parts of the home, such as a roof void
- it carries cold air through spaces that are within the insulated parts of the home.

This can be achieved by using suitable pre-insulated ductwork or a proprietary insulation system with a thermal resistance equivalent to a minimum of 25mm of insulating material, with a thermal conductivity of 0.04W/Mk.

Ductwork insulation, including that used for proprietary duct insulation systems and pre-insulated ducts, should be:

- inert, durable and suitable for use with the ductwork system
- continuous and vapour resistant
- not adversely affected by moisture vapour
- installed in a neat and workmanlike manner to ensure that there are no gaps
- installed in accordance with the manufacturer's recommendations.

Where a vapour control layer is incorporated, the joints should be sealed using appropriate tapes or sealants as recommended by the manufacturer.

Table 1: Ductwork insulation

Type of duct	Ductwork continuously insulated	
	Ductwork located inside the insulated part of the home	Ductwork located outside the insulated part of the home
Intake	Yes	Yes
Exhaust	Yes	Yes
Service (supply and extract)	No	Yes ⁽¹⁾

Note

1. Additional insulation should be provided to protect the system from the cold.

Any condensate that forms within the fan unit or ductwork should be able to drain to a suitable outfall. Fan units should be located to enable connection of the condensate drain to the soil and waste system via a dry trap.

8.4.1.3.7 Protection from the cold

MVHR systems should be protected from the effects of cold. Issues to be taken into account include:

- performance in relation to indoor air quality
- the manufacturer's recommendations where any parts are located outside the insulated part of the home
- insulation of ductwork and other system components.

Figure 3: Protection from the cold

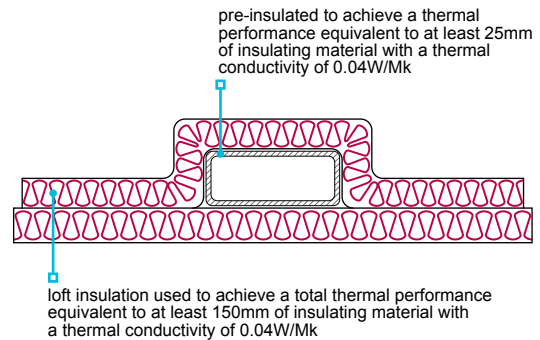

To prevent damage to the components and ensure satisfactory operation, MVHR systems should be fitted with automatic frost protection.

Horizontal sections of service ductwork, outside the insulated parts of the home, should be insulated to achieve a thermal resistance equivalent to at least 150mm of insulating material with a thermal conductivity of 0.04W/Mk. This may be achieved by installing the ductwork between the layers of horizontal insulation (see Figure 3).

Condensate drains located outside the insulated part of the home should be insulated to prevent freezing.

8.4.1.4 Acoustics

MVHR systems shall be designed to minimise disturbance caused by noise.

MVHR fan units should be sized to run at their optimum speed and to provide suitable performance whilst taking the resulting noise and vibration into account. Specifying MVHR fan units that can provide the required airflow rates when running at less than full speed can reduce unnecessary noise.

Ductwork should be sized to allow air to pass freely without causing excessive noise disturbance. To reduce noise transfer along ductwork, a short length of flexible duct can be installed adjacent to air valves and fan units. Other issues to be taken into account include:

- noise between habitable rooms
- external noise
- location of the MVHR fan unit
- the type of mountings used to secure the MVHR fan unit.

8.4.1.5 Building integration

Also see: Chapters 7.1, 7.2 and 8.6

MVHR systems shall be securely fixed and not adversely affect the weather resistance of the building.

Issues to be taken into account include:

- 1) weathertightness
- 2) fixing of fan units
- 3) fire-stopping.

8.4.1.5.1 Weathertightness

Proprietary roof terminals should be used to ensure the weathertightness of the roof covering.

8.4.1.5.2 Fixing of fan units

MVHR fan units should only be fixed to parts of the building capable of taking the load. Where MVHR fan units are supported by framed structures, additional components such as noggings may be required to provide a secure fixing point.

Fan units should be located, orientated and fixed in accordance with the design, using the clips, brackets and fixings recommended by the manufacturer.

8.4.1.5.3 Fire-stopping

MVHR systems should not adversely affect the fire performance of the building. Issues to be taken into account include:

- ensuring that the fire requirements of the building are in accordance with relevant Building Regulations
- suitable detailing of components passing through other elements of the building
- location and type of firestops to be used
- integrity of protected stairs and halls
- integrity of walls and floors.

Proprietary passive fire protection components should be suitably tested and specified to take account of the test conditions.

8.4.1.6 Ductwork

Also see: Clause 8.4.2.7

Ductwork design and the materials used should be suitable for the intended purpose and not adversely affect the performance of the building. MVHR ductwork and insulation should be installed to a satisfactory standard.

Where ductwork routes require alterations to structural elements, these should be in accordance with the manufacturer's recommendations or Technical Requirement R5.

Ductwork should:

- provide satisfactory performance for the life of the system
- be routed as directly as practicable
- be of a rigid or semi-rigid material suitable for use in MVHR systems (see Figure 4)
- be fixed in accordance with the manufacturer's recommendations.

Figure 4: Air valve and ductwork

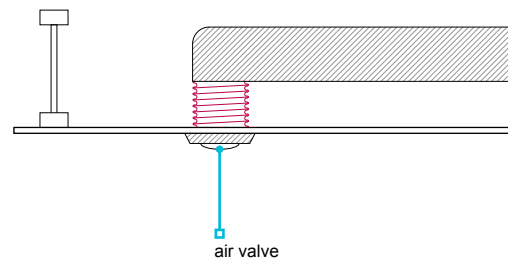

Bends, connections and junctions should be formed using proprietary components that are part of the ductwork system.

Flexible ducting should:

- only be located adjacent to fan units or air valves
- not be more than 300mm in length
- not be used to form bends.

8.4.1.7 Fixing and jointing of ductwork

MVHR ductwork and insulation shall be installed to a satisfactory standard. Issues to be taken into account include:

- 1) fixing
- 2) jointing.

Ductwork should be installed in a neat and workmanlike manner.

8.4.1.7.1 Fixing

To prevent condensate collecting, horizontal ductwork should be to a suitable outfall in accordance with the design and installed to a true line to avoid localised dips. Where parallel ductwork is run, it should be positioned to maintain an even gap.

Where ductwork passes through an external wall, it should be positioned to slope slightly downwards to prevent water entering the building.

Ductwork should be securely held in position by evenly spaced clips no more than 750mm apart, or in accordance with the ductwork manufacturer's recommendations.

Ductwork should not be in direct contact with other surfaces, such as plasterboard ceilings, that may transfer noise to the home.

8.4.1.7.2 Jointing of ductwork

The method and materials used for jointing ductwork should be specified by the duct manufacturer, and be:

- durable and airtight
- securely fixed
- sealed with purpose-designed connections in accordance with the manufacturer's recommendations.

Where tapes and sealants are used, they should be suitable for the intended purpose and be recommended by the ductwork manufacturer. Issues to be taken into account in relation to the durability of the joining method include:

- thermal movement
- moisture
- temperature
- compatibility with the duct material.

Tape should be installed in a neat and workmanlike manner, and surfaces should be dry and free from grease and dust before applying. Excess sealant should not extrude to the inside of the duct.

8.4.1.8 Access and operation

MVHR systems shall be designed and installed to ensure that the fan unit and associated controls are easily accessible for the purposes of cleaning, inspection, maintenance and repair or replacement.

Access should be provided to MVHR systems, including switchgear and controls. To enable the cleaning, inspection, maintenance and repair of systems. In accordance with the manufacturer's recommendations.

Where plant is to be installed in a loft or roof void, guidance is provided in Clause 7.2.12.

Table 2: Guidance for the suitable functioning of, and access to, the MVHR system

	Fan unit located inside the insulated part of the home	Fan unit located outside the insulated part of the home
Access	Access should not be obstructed and should be located to enable routine servicing to be carried out	A safe means of access, including a suitable walkway and a working platform 1m ² immediately adjacent to the MVHR fan unit, should be provided. The walkway and platform should be designed to ensure the continuity of any insulation, and the supporting structure should be designed to take account of the additional load
Control and functionality	Where a 'boost' function is provided, it should switch off automatically and be located in, or adjacent to, the room it serves. Where a 'summer bypass' function is provided, it should operate automatically and divert the airflow around the heat exchanger. The MVHR system should be capable of being isolated by a switched fused spur	
Indication and controls	MVHR systems should include visual indicators showing maintenance and servicing requirements, and mode of operation. These should be visible from within the insulated envelope, not obscured from view, and be simple to use	
Cleaning	To maintain operating performance, extract service ductwork and air valves should either be fitted with filters, or ductwork should be accessible for cleaning	

8.4.1.9 Electrical installation requirements

Also see: Clause: 8.1.6

The electrical installation shall be in accordance with relevant regulations.

Electrical installations should comply with BS 7671 Requirements for Electrical Installations.

The electrical installation should be capable of being isolated from all other electrical sources when required, for maintenance or testing.

8.4.1.10 Handling and storage

Materials, products, and systems shall be handled, stored and protected in a satisfactory manner to prevent damage, distortion, weathering and degradation.

MVHR systems should be:

- transported, lifted, handled and stored in accordance with the manufacturer's recommendations
- delivered in sequence to avoid storage
- protected to avoid the risk of damage.

To ensure performance, MVHR systems and ancillary components should be installed in a logical and timely sequence in accordance with the manufacturer's recommendations.

8.4.1.11 Commissioning and balancing

MVHR design, materials and sitework shall be tested and commissioned in accordance with the commissioning schedule.

Upon completion of the installation, MVHR systems should be protected from dust during the construction of the home. Where possible, the system should be switched off and dust covers applied to air valves.

Prior to completion of the home, the system:

- including ductwork and filters, should be checked to ensure it is clear from dirt and dust that may have accumulated during construction
- should be commissioned to confirm performance
- should be adjusted by using the air valves and controls to achieve the correct balancing and airflow rates
- should have air valves locked in position after correct commissioning and balancing.

Where the system cannot be balanced using the air valves and system controls, the complete system should be checked to ensure that it complies with the design.

Any changes from the design should be referred to the designer. Adjusting the fan speed above the designed output may result in noise disturbance and should be avoided.

A copy of the commissioning certificate should be made available to NHBC upon request.

8.4.1.12 Sequence of work

MVHR systems shall be installed in accordance with a suitable schedule.

To ensure performance, MVHR systems and ancillary components should be installed in a logical and timely sequence in accordance with the manufacturer's recommendations.

Mechanical extract ventilation systems (MEV)

Bathroom and kitchen extract fans providing decentralised extract ventilation (dMEV) or central mechanical extract ventilation (cMEV) and may be continuous or intermittent, depending on design and location.

8.4.2.1	Compliance	12
8.4.2.2	Provision of information	13
8.4.2.3	System design	13
8.4.2.4	Acoustics	15
8.4.2.5	Building integration	15
8.4.2.6	Ductwork	15
8.4.2.7	Fixing and jointing of ductwork	16
8.4.2.8	Access and operation	16
8.4.2.9	Electrical installation requirements	17
8.4.2.10	Handling and storage	17
8.4.2.11	Commissioning and balancing	17
8.4.2.12	Sequence of work	17



Figure reference table**Figure Reference Table 8.4.2**

Fig No	Title/Description	Chapter/Clause	Page
Figure 1	dMEV layout	8.4.2	12
Figure 2	cMEV layout	8.4.2	12
Figure 3	Ventilation control condensation — insulation	8.4.2.3.5	14
Figure 4	Ventilation control condensation — condensate trap	8.4.2.3.5	14
Figure 5	Termination to ventilation systems	8.4.2.3.6	14

Figure 1: dMEV layout

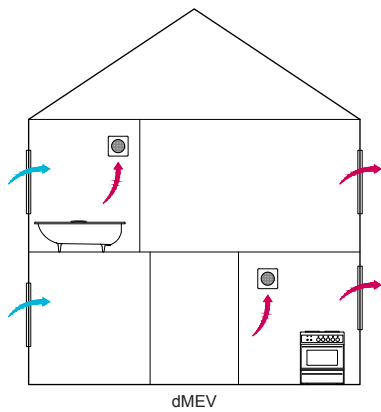
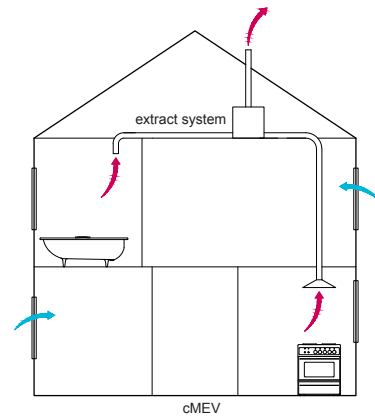

Figure 2: cMEV layout



Definitions for MEV

Air valve (extract)	Wall or ceiling mounted fittings used to balance the flow rate of air between rooms; may be referred to as grilles.
cMEV	Central mechanical extract ventilation system providing simultaneous ventilation to reduce excess moisture using multiple extraction points.
dMEV	Decentralised mechanical extract ventilation system providing ventilation to reduce excess moisture using single extraction point.
Exhaust ductwork	Carries air from the fan unit and exhausts it to the external atmosphere.
MEV	A generic term relating to both cMEV and dMEV.
Service ductwork extract	Carries air between the air valves and the MVHR fan unit.
Terminal fittings	Located on the outside of the building to finish the intake and exhaust ductwork.

8.4.2.1 Compliance

Also see: Chapter 2.1

MEV design, materials and sitework shall comply with the Technical Requirements. Issues to be taken into account include:

- 1) relevant standards
- 2) product certification
- 3) operative competency.

8.4.2.1.1 Relevant standards

Relevant standards include:

BS 476	Fire tests on building materials and structures
BS EN 1365-2	Fire resistance tests for loadbearing elements. Floors and roofs
BS EN 1366-3	Fire resistance tests for service installations. Penetration seals
BS EN ISO 12001	Noise emitted by machinery and equipment
Approved Document F England	Ventilation
Technical handbook Scotland	Section 3 Ventilation
Technical Booklet NI	Part K Ventillation

8.4.2.1.2 Product certification

MEV appliances should hold a current assessment by an appropriate independent technical approvals authority accepted by NHBC confirming compliance with UKCA, UKNI or CE marking. A Declaration of Conformity detailing the standards the product complies with and documents should be available on request.

8.4.2.1.3 Operative competency

MEV systems should be installed by competent operatives who are:

- familiar with the system being installed, or
- certified to a standard acceptable to NHBC.

8.4.2.2 Provision of information

Designs and specifications shall be produced in a clearly understandable format, include all relevant information and be distributed to the appropriate personnel.

Provision of information is important as it allows for energy-efficient use of the building and common methods adopted to prevent overheating.

Clear and fully detailed drawings should be available on site to enable work to be carried out in accordance with the design. Design and specification information should be issued to site supervisors, relevant specialist subcontractors and suppliers, and include the following information:

- fixing schedule
- a full set of current drawings
- indication of which manufacturer and/or installer is responsible for each system and interface
- commissioning schedule
- manufacturers' specifications
- interface details
- on-site testing requirements
- type and spacing of clips and fixings
- type and location of ancillary components, including those used for fire safety and acoustic purposes
- commissioning certificates
- location of all ductwork runs, the fan unit and controls
- type, size and position of ducts and terminals
- direction of fall for horizontal ductwork
- designed airflow-balancing figures for the system
- thermal modelling.

8.4.2.3 System design

MEV systems shall be designed to minimise disturbance caused by noise. Issues to be taken into account include:

- 1) location
- 2) system
- 3) compatibility
- 4) performance
- 5) control of condensation
- 6) terminals.

8.4.2.3.1 Location

MEV systems should be correctly located, including ancillary components, in accordance with the manufacturer's recommendations. The route of ductwork should take account of other building elements. Ductwork passing through structural elements should not adversely affect the structural or fire performance of the building. Where alterations to structural elements, such as I-joists, are required, this should only be carried out in accordance with the manufacturer's recommendations or be designed by an engineer in accordance with Technical Requirement R5.

The fire requirements of the building should be in accordance with relevant Building Regulations and standards. Issues that should be taken into account include:

- suitable detailing of components passing through other elements of the building
- the location and type of dampers and firestops to be used
- the integrity of protected stairs and halls
- the integrity of walls and floors.

8.4.2.3.2 System

MEV systems should be in accordance with relevant Building Regulations and installed to ensure that effective ventilation is provided without affecting health or creating unnecessary noise.

8.4.2.3.3 Compatibility

MEV systems should ensure compatibility with other building elements and not adversely affect the performance of the building.

MEV systems should be designed as a complete package, taking into account the performance of all components and materials, to ensure compatibility, and in accordance with the performance requirements of the system.

Particular consideration should be given where components from different manufacturers are specified on the same system.

8.4.2.3.4 Performance

The MEV system should be designed to provide satisfactory performance and be installed according to the design and manufacturer's recommendations. Variations from the design should maintain the satisfactory performance of the system and be approved by the designer.

Issues that should be taken into account include:

- ventilation rates as set out in appropriate Building Regulations and standards
- fan capacity, accounting for airflow resistance of the system
- ensuring the even distribution of air flow, regulations, standards and airflow resistance, including from bends and fittings.

Airflow resistance should be calculated using figures for air valves and terminals determined in accordance with BS EN 13141-2 and data supplied by the duct manufacturer. Ductwork should be as direct as possible to reduce the number of bends.

Allowance should be made for air transfer within the home. Where gaps between the underside of internal doors and the floor finish are used for air transfer, the guidance in Chapter 9.1 A consistent approach to finishes should be considered.

8.4.2.3.5 Control of condensation

Where extract ductwork passes through unheated spaces, it should be continuously insulated to achieve a thermal resistance equivalent to a minimum of 25mm of insulating material with a thermal conductivity of 0.04W/(mK). This can be achieved by using:

- suitable pre-insulated ductwork, or
- a proprietary insulation system (see Figure 3).

Alternatively, the ductwork can be fitted with a condensate trap that discharges to the outside or the duct can be installed to slope to the outside (see Figure 4).

Figure 3: Ventilation control condensation — insulation

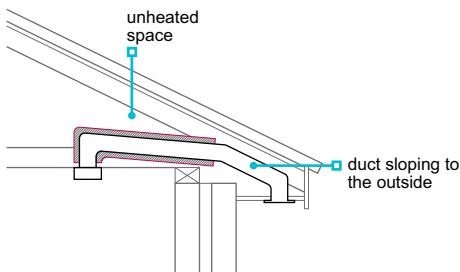
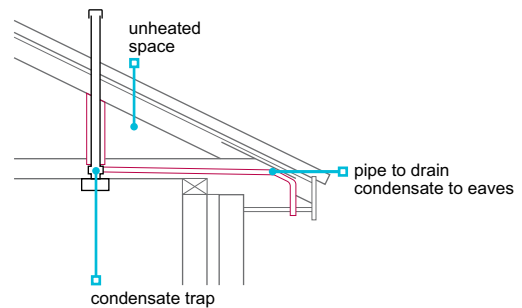

Figure 4: Ventilation control condensation — condensate trap



8.4.2.3.6 Terminals

Ventilation systems should terminate freely to open air.

The airflow resistance of terminals should not adversely affect the performance of the ventilation system. Airflow resistance of terminals can be obtained through testing in accordance with BS EN 13141-2 (see Figure 5).

Figure 5: Termination to ventilation systems

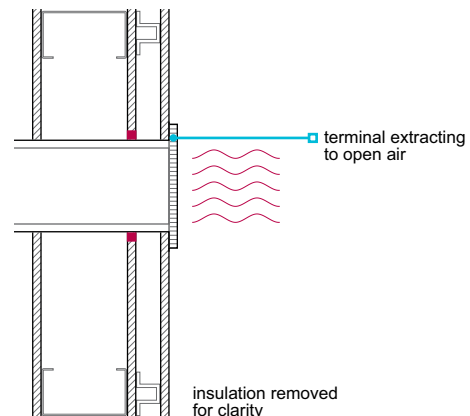

8.4.2.4 Acoustics

MEV systems shall be designed to minimise disturbance caused by noise.

MEV fan units should be sized to run at their optimum speed and to provide suitable performance whilst taking the resulting noise and vibration into account. Specifying MEV fan units that can provide the required airflow rates when running at less than full speed can reduce unnecessary noise.

Ductwork should be sized to allow air to pass freely without causing excessive noise disturbance. To reduce noise transfer along ductwork, a short length of flexible duct can be installed adjacent to air valves and fan units. Other issues to be taken into account include:

- noise between habitable rooms
- external noise
- location of the MEV fan unit
- the type of mountings used to secure the MEV fan unit.

8.4.2.5 Building integration

Also see: Chapters 7.1, 7.2 and 8.6

MEV design, materials and sitework shall comply with the Technical Requirements. Issues to be taken into account include:

- 1) weathertightness
- 2) fixing of fan units
- 3) fire-stopping.

8.4.2.5.1 Weathertightness

Proprietary roof terminals should be used to ensure the weathertightness of the roof covering.

8.4.2.5.2 Fixing of fan units

MEV fan units should only be fixed to parts of the building capable of taking the load. Where MEV fan units are supported by framed structures, additional components such as noggings may be required to provide a secure fixing point.

Fan units should be located, orientated and fixed in accordance with the design, using the clips, brackets and fixings recommended by the manufacturer.

The type, size, number, position and fitting tolerance of fixings should be in accordance with the manufacturer's recommendations.

8.4.2.5.3 Fire-stopping

The MEV system should not adversely affect the fire performance of the building. Issues to be taken into account include:

- ensuring that the fire requirements of the building are in accordance with relevant Building Regulations
- suitable detailing of components passing through other elements of the building
- location and type of firestops to be used
- integrity of protected stairs and halls
- integrity of walls and floors.

Proprietary fire components should be suitably tested and specified to take account of the test conditions.

8.4.2.6 Ductwork

Also see: Clause 8.4.1.6

Ductwork to intermittent and continuously running MEV systems shall ensure satisfactory performance and durability. Issues to be taken into account include:

- 1) resistance to airflow
- 2) installation of ductwork.

8.4.2.6.1 Resistance to airflow

Ductwork systems should be designed to minimise the resistance to airflow and be formed from compatible components.

Rigid duct is preferable to flexible, but where flexible duct is used, it should be restricted in length to ensure that the airflow resistance does not prevent the designed ventilation rate from being achieved. Flexible duct should be installed:

- straight
- in accordance with the manufacturer's recommendations.

Bends should generally be formed with proprietary rigid components. Where flexible duct is used to form bends on an intermittent extract system, they should be restricted to a maximum of:

- two for systems up to 30 L/s
- one for extract rates higher than 30 L/s.

8.4.2.6.2 Installation of ductwork

Ductwork should be installed in a neat and workmanlike manner, be securely fixed and have:

- adequate support throughout its length
- sealed mechanically fixed joints and connections.

Where ductwork passes through an external wall, it should be positioned to slope slightly outwards to prevent water entering the building. Clips and supports for ductwork should be spaced at equal distances and in accordance with the ductwork manufacturer's recommendations. For rigid ductwork, they should not generally be more than 750mm apart.

Ductwork should not be in direct contact with other surfaces, such as plasterboard ceilings, that may transfer noise to the home.

It is not necessary to provide non-return shutters on extract fans or cooker hoods or their ducting unless specifically required by the manufacturer's installation instructions.

8.4.2.7 Fixing and jointing of ductwork

MEV ductwork and insulation shall be installed to a satisfactory standard. Issues to be taken into account include:

- 1) fixing
- 2) jointing of ductwork.

Ductwork should be installed in a neat and workmanlike manner.

8.4.2.7.1 Fixing

To prevent condensate collecting, horizontal ductwork should be to a suitable outfall in accordance with the design and installed to a true line to avoid localised dips. Where parallel ductwork is run, it should be positioned to maintain an even gap.

Where ductwork passes through an external wall, it should be positioned to slope slightly downwards to prevent water entering the building.

Ductwork should be securely held in position by evenly spaced clips no more than 750mm apart, or in accordance with the ductwork manufacturer's recommendations.

Ductwork should not be in direct contact with other surfaces, such as plasterboard ceilings, that may transfer noise to the home.

8.4.2.7.2 Jointing of ductwork

The method and materials used for jointing ductwork should be specified by the duct manufacturer, and be:

- durable and airtight
- sealed with purpose-designed connections in accordance with the manufacturer's recommendations.
- securely fixed

Where tapes and sealants are used, they should be suitable for the intended purpose and be recommended by the ductwork manufacturer. Issues to be taken into account in relation to the durability of the jointing method include:

- thermal movement
- temperature
- moisture
- compatibility with the duct material.

Tape should be installed in a neat and workmanlike manner, and surfaces should be dry and free from grease and dust before applying. Excess sealant should not extrude to the inside of the duct.

8.4.2.8 Access and operation

MEV systems shall be designed and installed to ensure that the fan unit and associated controls are easily accessible for the purposes of cleaning, inspection, maintenance and repair or replacement.

Access should be provided to MEV systems, including switchgear and controls. To enable the cleaning, inspection, maintenance and repair of systems. In accordance with the manufacturer's recommendations.

Where plant is to be installed in a loft or roof void, guidance is provided in Clause 7.2.12.

8.4.2.9 Electrical installation requirements

Also see: Clause: 8.1.6

The electrical installation shall be in accordance with relevant regulations.

Electrical installations should comply with BS 7671 Requirements for Electrical Installations.

The electrical installation should be capable of being isolated from all other electrical sources when required, for maintenance or testing.

8.4.2.10 Handling and storage

Materials, products and systems shall be handled, stored and protected in a satisfactory manner to prevent damage, distortion, weathering and degradation.

MEV systems should be:

- transported, lifted, handled and stored in accordance with the manufacturer's recommendations
- delivered in sequence to avoid storage
- protected to avoid the risk of damage.

8.4.2.11 Commissioning and balancing

MEV design, materials and sitework shall be tested and commissioned in accordance with the commissioning schedule.

Upon completion of the installation, MEV systems should be protected from dust during the construction of the home. Where possible, the system should be switched off and dust covers applied to air valves.

8.4.2.12 Sequence of work

MEV systems shall be installed in accordance with a suitable schedule.

To ensure performance, MEV systems and ancillary components should be installed in a logical and timely sequence in accordance with the manufacturer's recommendations.



Chapter 8.5



LZC hot water systems

This chapter provides guidance for equipment and installation of low or zero carbon sources (LZC) that provide hot water only. Other LZC systems that follow the general principles of this chapter may also be acceptable, subject to specific agreement with NHBC.

This chapter contains the following sections:

8.5.1 Solar thermal hot water systems





Chapter

8.5.1



Solar thermal hot water systems

Systems which convert solar radiation energy to space and/or water heating.

8.5.1.1	Compliance	02
8.5.1.2	Provision of information	03
8.5.1.3	System design	03
8.5.1.4	Safe discharge	04
8.5.1.5	Building integration	04
8.5.1.6	Fixing	04
8.5.1.7	Access	05
8.5.1.8	Electrical installation requirements	05
8.5.1.9	Handling and storage	05
8.5.1.10	Handover requirements	05
8.5.1.11	Sequence of work	05



Figure reference table**Figure Reference Table 8.5.1**

Fig No	Title/Description	Chapter	Page
Figure 1	Solar thermal schematic	8.5.1	2
Figure 2	Solar thermal fixing	8.5.1.5	4

Figure 1: Solar thermal schematic

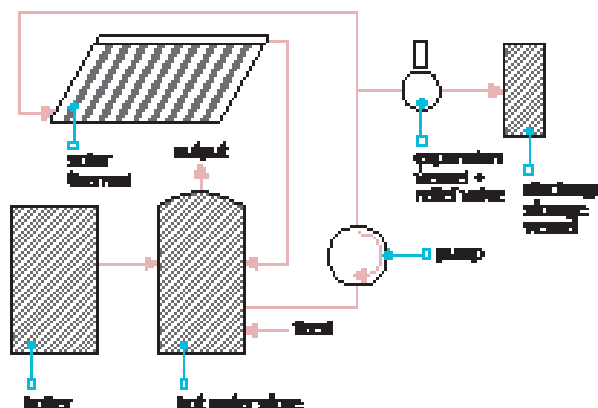

Definitions for solar thermal hot water systems

Coastal locations	A site within a distance of 500m from the general coastline of the United Kingdom.
Low or zero carbon (LZC) technologies	A term applied to renewable sources of energy, and also to technologies which are significantly more efficient than traditional solutions, or which emit less carbon in providing heating, cooling or power.
Performance	The manner or quality of functioning for a material, product or system.
Renewable energy	Energy from naturally available sources that can be replenished, including energy from the sun, wind and tides, and from replaceable matter such as wood or other plant material.

8.5.1.1 Compliance

Also see: Chapter 2.1

Solar thermal hot water systems shall comply with the Technical Requirements. Issues to be taken into account include:

- 1) relevant standards
- 2) product certification
- 3) operative competency.

LZC technologies that comply with the guidance in this chapter will generally be acceptable.

8.5.1.1.1 Relevant standards

Solar thermal hot water systems should comply with relevant standards, including where applicable:

BS EN 12975-1	Thermal solar systems and components. Solar collectors
BS EN 12976-1	Thermal solar systems and components. Factory made systems
BS EN ISO 9806	Solar energy. Solar thermal collectors. Test methods
BRE Digest 489	Wind loads on roof-mounted photovoltaic and solar thermal systems
MCS 004	Microgeneration Certification Scheme requirements for solar collectors
MCS 012	Solar roof fixing standard
MIS 3001	Microgeneration Installation Standard for solar thermal installation

8.5.1.1.2 Product certification

Solar thermal hot water technologies should have current certification confirming satisfactory assessment by an appropriate independent authority acceptable to NHBC.

Solar thermal products that are certified through the Microgeneration Certification Scheme (MCS) will generally be acceptable to NHBC. Certification and test documentation should be made available to NHBC upon request.

Other certification bodies or test documentation may be acceptable where they are considered by NHBC to be a suitable alternative.

8.5.1.1.3 Operative competency

Solar thermal hot water systems should be installed by companies, organisations or operatives who are:

- competent and familiar with the system being installed, and
- certified to a standard acceptable to NHBC.
- MCS Certified, or

8.5.1.2 Provision of information

Designs and specifications shall be produced in a clearly understandable format, include all relevant information and be distributed to the appropriate personnel.

Provision of information is important as it allows for energy-efficient use of the building and common methods adopted to prevent overheating.

Clear and fully detailed drawings should be available on site to enable work to be carried out in accordance with the design. Design and specification information should be issued to site supervisors, relevant specialist subcontractors and suppliers, and include the following information:

- fixing schedule
- a full set of current drawings
- indication of which manufacturer and/or installer is responsible for each system and interface
- commissioning schedule
- manufacturers' specifications
- interface details
- on-site testing requirements
- type and spacing of clips and fixings
- type and location of ancillary components, including those used for fire safety and acoustic purposes
- commissioning certificates
- location and size of water storage cisterns and cylinders
- hot water pipe runs.

8.5.1.3 System design

Solar thermal hot water systems shall be designed to ensure satisfactory performance. Issues to be taken into account include:

- | | |
|-------------|------------------|
| 1) location | 3) compatibility |
| 2) system | 4) performance. |

8.5.1.3.1 Location

Solar thermal hot water systems should be correctly located.

Solar thermal collectors, including ancillary components, should be located and identified in accordance with the manufacturer's recommendations.

Solar thermal hot water systems, when sited in coastal locations, should be suitable for the environment. Manufacturers' recommendations should be followed detailing requirements.

8.5.1.3.2 System

Solar thermal hot water systems should be designed in accordance with the manufacturer's recommendations, certification scheme requirements and appropriate standards.

Each system should generally be supplied from one manufacturer as a package, not as individual components or materials. However, where components from more than one manufacturer are used, they should be compatible to ensure satisfactory performance.

Solar thermal systems should be designed to prevent stagnation and damage to the collectors from oversizing.

8.5.1.3.3 Compatibility

Solar thermal hot water systems should be installed so as not to adversely affect the performance of the building to which they are fixed, and in accordance with the manufacturer's recommendations.

Multiple systems should be compatible with each other.

8.5.1.3.4 Performance

Solar thermal hot water systems designed to contribute towards space and water heating should be designed in accordance with the performance requirements in Chapter 8.3 Space heating systems and Clause 8.1.8.

8.5.1.4 Safe discharge

Discharge from solar thermal hot water systems shall terminate safely.

Solar thermal hot water systems should discharge into a storage vessel. The discharge pipework and vessel should be suitable to withstand high temperatures.

8.5.1.5 Building integration

Also see: Clauses 7.2.15, 7.2.17 and Chapter 8.6

Solar thermal hot water system installation shall be securely fixed and not adversely affect the weather resistance of the building.

Foundations and anchor points for stand-alone solar thermal technologies should be designed by an engineer in accordance with Technical Requirement R5 to withstand the structural forces acting upon them.

The structure to which the solar thermal technology is attached should be assessed according to its ability to accept the loadings and prevent detrimental effects arising from movement or vibration.

The design of the structure should take account of:

- the self-weight of the solar thermal components
- imposed loads
- wind loads
- dynamic loading (where relevant).

Notching, drilling or chasing of structural components to accommodate service pipes or cables should either comply with Clause 8.6.2.7 or be designed by an engineer in accordance with Technical Requirement R5.

Fixings, supports, bracketry and mounting frames should:

- accommodate all static and dynamic loads in accordance with the manufacturer's recommendations
- have adequate protection against corrosion (grade 316 stainless steel is recommended for coastal locations)
- be compatible or isolated where two metals are to be joined to prevent bimetallic corrosion.

Figure 2: Solar thermal fixing

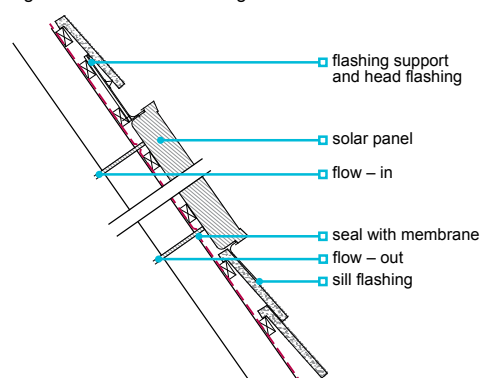

Aluminium and aluminium alloys should not come into contact with cementitious material.

All interfaces between the LZC technology and the building should ensure adequate weather resistance, and be sealed to limit air leakage and prevent moisture from reaching the interior or any part of the structure that could be adversely affected by its presence. The envelope should be weatherproofed using appropriate flashings and fixings. Weatherproofing details that rely solely on sealant are not acceptable.

8.5.1.6 Fixing

Solar thermal hot water systems shall be securely fixed using durable materials.

Fixings should comply with the types listed in Table 1.

Table 1: Materials suitable for fixings

Fixing material	Guidance
Phosphor bronze	NA
Silicon bronze	NA
Stainless steel	BS EN ISO 3506
Mild steel	Coatings to BS EN ISO 2081, BS EN ISO 2082, BS EN 1461 or other appropriate treatment in accordance with BS EN ISO 12944 or BS EN ISO 14713
Aluminum alloy	BS EN 573 and BS EN 755
Stainless steel	BS EN 10088
Mild steel	BS EN 10346
Other materials	Assessed in accordance with Technical Requirement R3

Materials that comply with recognised standards, which provide equal performance to (or better than) those Table 22, are also acceptable.

The type, size, number, position and fitting tolerance of fixings should be in accordance with the manufacturer's recommendations.

Issues that should be taken into account include:

- the provision of suitable locking nuts and washers
- the isolation of aluminium from cementitious material.
- the isolation of dissimilar metals

8.5.1.7 Access

Solar thermal systems shall be designed and installed to ensure the collectors and associated controls are easily accessible for the purposes of cleaning, inspection, maintenance and repair or replacement.

Safe access should be provided to the solar thermal system, including switchgear and controls. This is to enable the cleaning, inspection, maintenance and repair of systems. Access should be provided in accordance with the manufacturer's recommendations.

8.5.1.8 Electrical installation requirements

Also see: Clause 8.1.6

The electrical installation shall be in accordance with relevant regulations.

Electrical installations should comply with BS 7671 Requirements for Electrical Installations.

The electrical installation should be capable of being isolated from all other electrical sources when required, for maintenance or testing.

8.5.1.9 Handling and storage

Materials, products and systems shall be handled, stored and protected in a satisfactory manner to prevent damage, distortion, weathering and degradation.

Solar thermal systems should be:

- transported, lifted, handled and stored in accordance with the manufacturer's recommendations
- delivered in sequence to avoid storage
- protected to avoid the risk of damage.

8.5.1.10 Handover requirements

Detailed information and instructions shall be provided to the homeowner.

The pack of information provided to the homeowner should include:

- user instructions for the systems installed
- contact details for the manufacturer and installer
- key components installed
- a completed manufacturer's certificate from an acceptable independent assessment organisation, MCS or suitable alternative
- maintenance and servicing requirements
- warranties and/or guarantees
- recommendations should be given on how solar collectors should be protected from distortion if not filled with solar fluid in line with manufacturer's recommendations.

8.5.1.11 Sequence of work

Solar thermal hot water systems shall be installed in accordance with a suitable schedule.

To ensure performance, solar thermal hot water systems and ancillary components should be installed in a logical and timely sequence in accordance with the manufacturer's recommendations.



Chapter 8.6



Installation and commissioning

This chapter provides guidance for installation, insulation to services, commissioning, and handover requirements for information to be provided to the homeowner.

This chapter should be used as extended information for Chapters 8.1 to 8.5.

8.6.1	Compliance	02
8.6.2	Installation	02
8.6.3	Insulation to services	04
8.6.4	Insulation performance	07
8.6.5	Testing and commissioning	08
8.6.6	Handover requirements	08



Figure reference table

Figure Reference Table 8.6

Fig No	Title/Description	Clause	Page
Figure 1	Vertical and horizontal chases	8.6.2.2	2
Figure 2	Pipes in screed	8.6.2.2	2
Figure 3	Notches and holes in solid timber joists	8.6.2.7	3
Figure 4	Notches and holes in joist's safe zones	8.6.2.7	3
Figure 5	Insulation to space heating systems without storage	8.6.3.3	5
Figure 6	Loft area	8.6.3.3	5
Figure 7	Garage and void area	8.6.3.3	5
Figure 8	Insulation to space heating systems with storage	8.6.3.4	6
Figure 9	Loft area	8.6.3.4	6
Figure 10	Garage and void area	8.6.3.4	6
Figure 11	Airing cupboard	8.6.3.4	6

Definitions

Dwellings	Self-contained units to accommodate a single household.
Primary circulation	An assembly of water fittings in which water circulates between a heat source and a primary heat exchanger inside a hot water storage vessel, including any space heating system.
Secondary circulation	An assembly of water fittings in which water circulates in supply pipes or distributing pipes of hot water storage systems.

8.6.1 Compliance

Installation and commissioning shall comply with the Technical Requirements.

8.6.2 Installation

Internal services shall not adversely affect the stability of the home and be installed to ensure satisfactory operation. Issues to be taken into account include:

- 1) incoming services
- 2) concealed services
- 3) stability
- 4) locating plastic pipes
- 5) jointing of pipes
- 6) fire-stopping
- 7) notching and drilling of joints.

8.6.2.1 Incoming services

Incoming services should:

- comply with Chapter 5.1 Substructure and ground-bearing floors where they pass through the substructure
- be protected by a sleeve, or ducted, when passing through structural elements and not solidly embedded
- not be located in the cavity of an external wall, except for electricity meter tails
- not be buried in screeds unless permitted by relevant codes of practice.

8.6.2.2 Concealed services

Services concealed in walls or floors should be located so that significant cracking of the surface does not occur.

Where chases in walls are necessary, their depth should not exceed:

- 1/6 thickness of the single leaf for horizontal chases
- 1/3 thickness for vertical chases.

Hollow blocks should not be chased unless specifically permitted by the manufacturer.

Where pipes are permitted in floor screeds (see Figure 2), they should:

- be protected by wrapping or ducting as required
- have adequate allowance for thermal expansion, particularly at changes of direction
- be installed to the manufacturers recommendations where underfloor heating is installed.

Screed cover should be a minimum of 25mm over pipes and insulating material, and:

- where pipes cross, it may be necessary to form a duct to achieve adequate cover
- for in-situ suspended concrete floors, the location and depth of pipes should be approved by the designer.

Figure 1: Vertical and horizontal chases

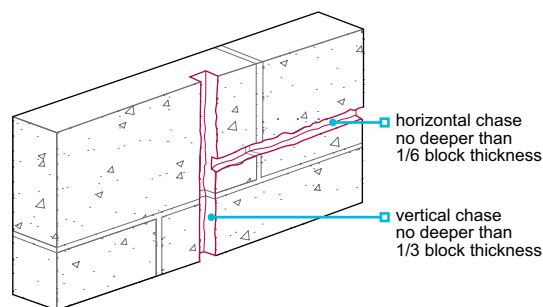
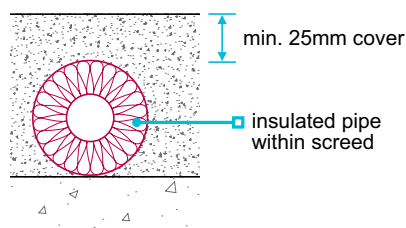

Figure 2: Pipes in screed



8.6.2.3 Stability

Pipes should:

- be adequately secured with suitable clips or brackets
- be installed neatly with clips spaced to prevent sagging, but not restrict thermal movement
- have adequate falls (where appropriate)
- be installed with adequate room for thermal expansion and contraction to avoid damage and noise.

8.6.2.4 Locating plastic pipes

Metallic tape should be placed behind plastic pipework, where it is concealed behind wall surfaces and would otherwise not be located by a metal detector or similar equipment.

8.6.2.5 Jointing of pipes

Joints in pipes should be made:

- strictly in accordance with the manufacturer's instructions
- using lead-free solder and flux recommended by the pipe manufacturer, with traces removed immediately after jointing.

8.6.2.6 Fire-stopping

Fire-stopping should be provided around any services which penetrate fire-resisting floors, walls or partitions. Where a proprietary system, such as an intumescent seal, is used, it should be installed in accordance with the manufacturer's instructions.

8.6.2.7 Notching and drilling of joists

Notching, drilling and chasing to accommodate service pipes and cables should either:

- comply with Table 1, or
- be designed by an engineer.

Solid timber and studs

Table 1: Limits for notching and drilling solid timber members

	Location	Maximum size
Notching joists up to 250mm in depth	Top edge 0.1-0.2 x span	0.15 x depth of joist
Drilling joists up to 250mm in depth	Centre line 0.25-0.4 x span	0.25 x depth of joist
Drilling studs	Centre line 0.25-0.4 x height	0.25 x depth of stud

Figure 3: Notches and holes in solid timber joists

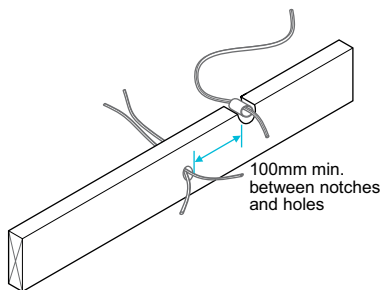
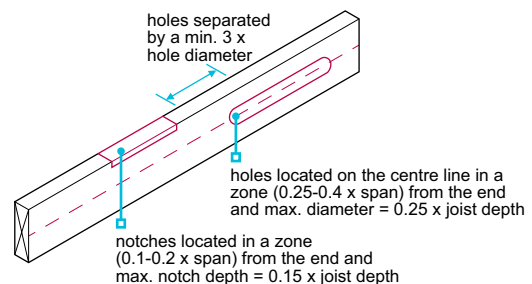

Figure 4: Notches and holes in joist's safe zones



Where the structural strength is impaired by notching or drilling, the element should be replaced or correctly repaired.

Holes should be spaced at a minimum of three times the hole diameter.

Notches and holes in the same joist should be separated by a minimum horizontal distance of 100mm.

Instructions should be obtained from the designer when notching and drilling, where:

- the joist is deeper than 250mm, or
- the dimensions are not in accordance with Table 1, or
- it is close to heavy loads, such as those from partitions, cisterns, cylinders and stair trimming.

I-joists

Preformed holes are provided, and additional holes and notches should not be cut without the approval of the manufacturer.

Metal web joists

Services should run in the gaps between the metal webs. Conduits may need to be inserted before the joists are fixed in position.

Lightweight steel

Lightweight steel should be used in accordance with Chapter 6.10 Light steel framed walls and floors.

8.6.3 Insulation to services

Also see: Clause 7.2.15

Insulation to internal services shall be in accordance with relevant Building Regulations and installed to minimise the effects of freezing, overheating or energy wastage. Issues to be taken into account include:

- 1) space heating and hot water
- 2) intermediate floors
- 3) systems without hot water storage
- 4) systems using hot water storage.

8.6.3.1 Space heating and hot water

Pipework serving space heating and hot water systems should be insulated in all areas outside of the heated building envelope. In addition, pipes should be insulated under the following conditions:

- all primary flow and return pipework from the heat source to hot water storage cylinder including where they pass through an intermediate floor void
- any secondary return circuits
- any pipework, flow and return, hot or cold distribution or feed pipe within 1m minimum of the cylinder
- meet the minimum pipe insulation requirements of Clause 8.6.4.

8.6.3.2 Intermediate floors

Where pipework is installed within intermediate floors, it should be insulated over the complete length.

When installing pipes through timber joists, to prevent excessive hole diameters, the insulation should only be applied between each joist; the pipes should be wrapped where they pass through the joist so they can move freely and without noise.

8.6.3.3 Systems without hot water storage

Also see: Clause 8.1.8

The following pipework should be insulated:

- pipework within a garage (outside the heated living space)
- pipework that passes through a roof space (outside the heated living space)
- pipework that passes through an external wall cavity, that is on the cold side of the external wall insulation (outside the heated living space).

Pipework should be insulated to meet the minimum requirements in Clause 8.6.4.

Figure 5: Insulation to space heating systems without storage

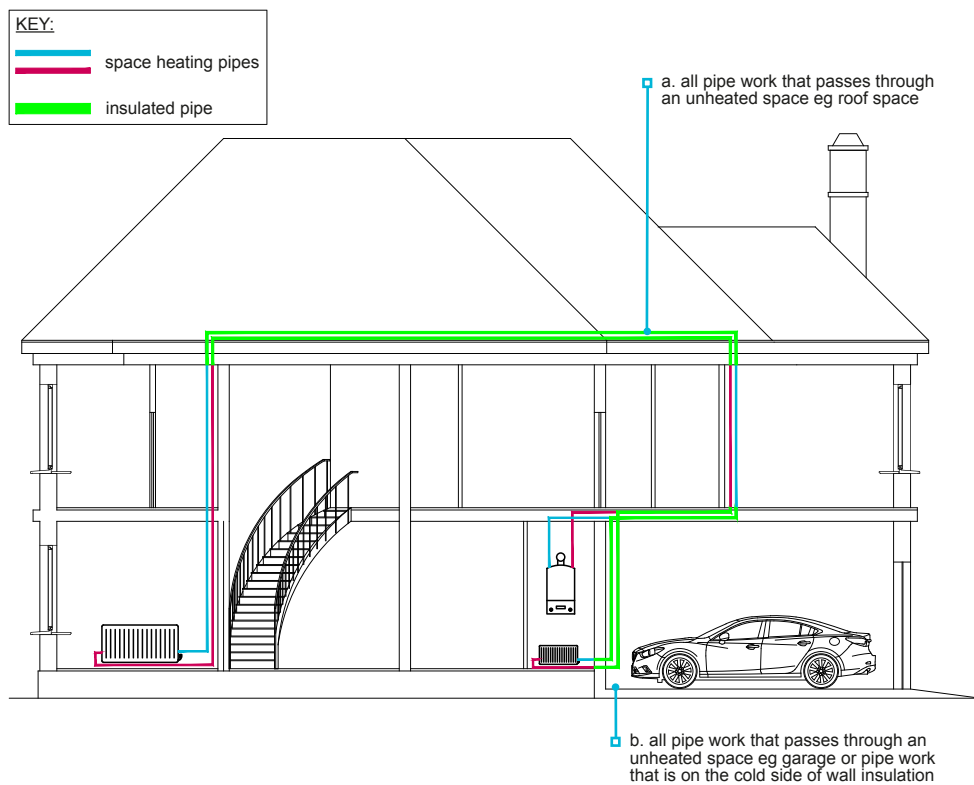

Figure 6: Loft area

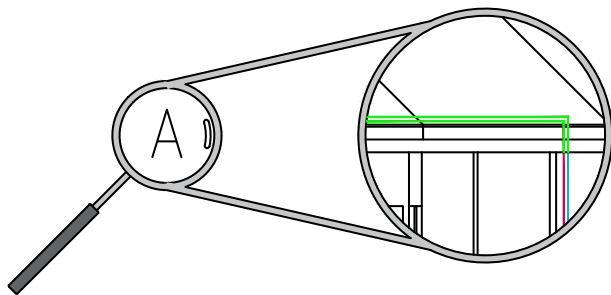
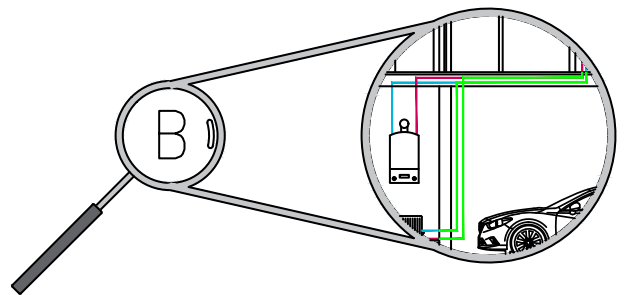

Figure 7: Garage and void area



8.6.3.4 Systems using hot water storage

The following pipework should be insulated:

- pipework within a garage (outside the heated living space)
- pipework that passes through a roof space (outside the heated living space)
- pipework that passes through an external wall void that is on the cold side of the external wall insulation (outside the heated living space)
- all hot water primary flow and return pipework including where they pass through an intermediate floor (void)
- pipework within 1m of the hot water storage cylinder.

If secondary circulation is used, insulate all pipework that is kept hot by that circulation.

Pipe insulation and hot water cylinders should be insulated to meet minimum requirements in Clause 8.6.4.

Figure 8: Insulation to space heating systems with storage

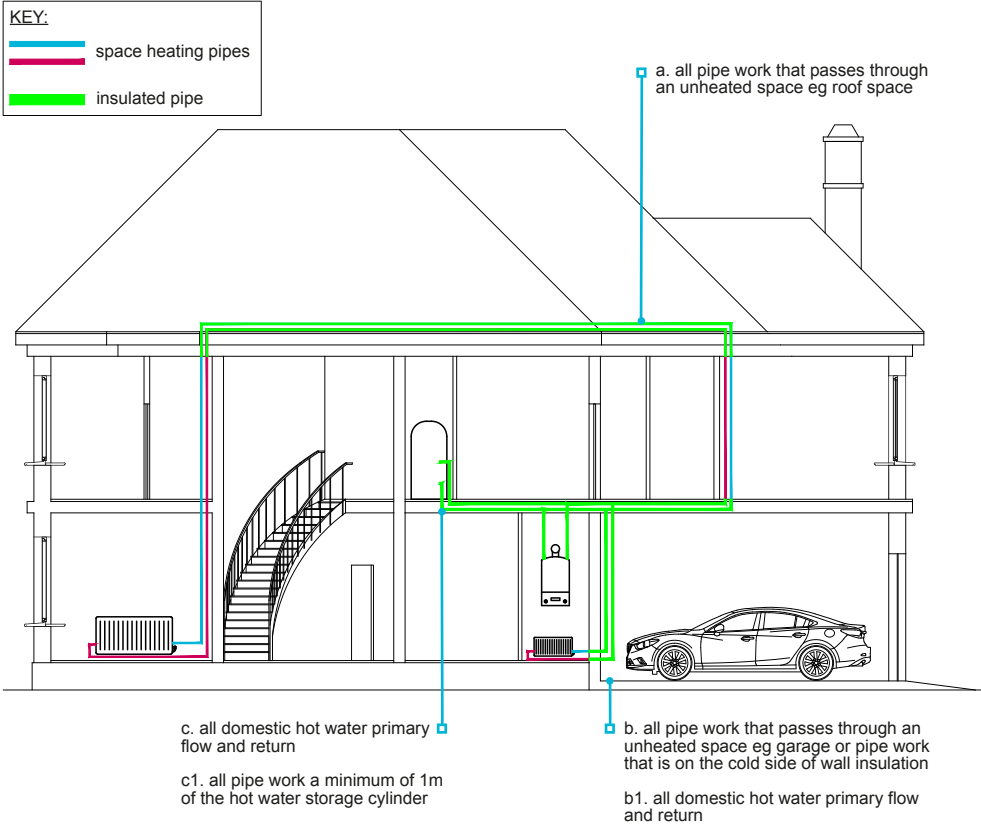

Figure 9: Loft area

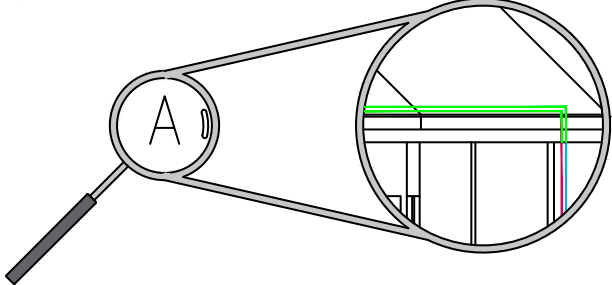

Figure 10: Garage and void area

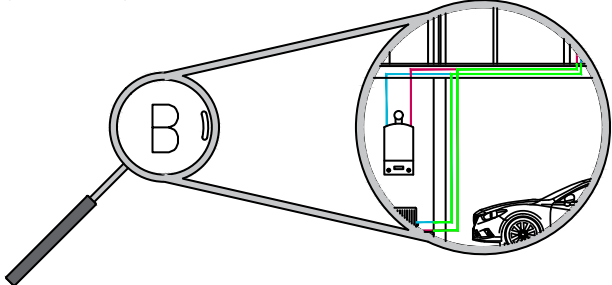
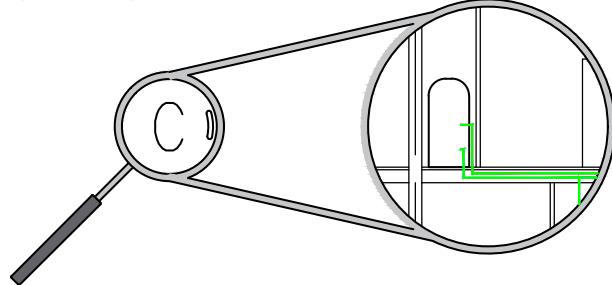

Figure 11: Airing cupboard



8.6.4 Insulation performance

Insulation performance shall comply with national standards. Issues to be taken into account include:

- 1) thermal conductivity and pipe insulation size
- 2) maximum daily hot water loss for hot water storage systems.

8.6.4.1 Thermal conductivity and pipe insulation size

Minimum thickness of pipework insulation for hot water services and space heating applications using high performance insulation see Table 2:

- all insulation should be designed so that the permissible heat losses in BS 5422 for hot water services at 60°C are not exceeded for the different pipe sizes
- this table relates to both plastic and metal pipes.

Table 2: Pipe insulation thickness for high emissivity (ϵ) outer surface = 0.90

Outside diameter of pipe on which insulation thickness is based mm	Thermal conductivity at 40°C W/m/K (insulation thickness in mm)					Maximum permissible heat loss W/m
	0.025	0.03	0.035	0.04	0.045	
8	5	7	9	12	16	7.06
10	6	8	11	15	20	7.23
12	7	10	14	18	23	7.35
15	9	12	15	20	26	7.89
22	11	14	18	23	29	9.12
28	12	16	20	25	31	10.07
35	13	17	22	27	33	11.08

For low emissivity, see BS 5422. Thermal insulating materials for pipes, tanks, vessels, ductwork and equipment operating within the temperature range -40°C to +700°C.

8.6.4.2 Maximum daily hot water loss for hot water storage systems

Maximum daily heat loss for hot water storage cylinder should comply with Table 3 below.

Table 3: Hot water storage heat loss

Nominal volume (litres)	Heat loss kWh/24h
50	1.03
100	1.49
150	1.88
200	2.06
250	2.22
300	2.36
350	2.48
400	2.59
500	2.80

8.6.5 Testing and commissioning

Services and LZC technologies shall be tested and commissioned to ensure satisfactory operation and, where appropriate, in accordance with the commissioning schedule.

Before completion and handover of the building, services should be tested and commissioned in accordance with relevant regulations and codes of practice.

The installer should check that the system is in accordance with the certification requirements, the manufacturer's recommendations and the design. Issues to be taken into account include:

- the safety of the system
- the correct installation of the system
- the correct operation of the system.

The commissioning engineer should ensure leaks or other defects are made good prior to the application of finish and handover of the home.

Upon completion, the installer should provide a certificate to confirm that the LZC technology has been installed, tested and commissioned in accordance with the above.

8.6.6 Handover requirements

Detailed information and instructions shall be provided to the homeowner.

The pack of information provided to the homeowner should include:

- user instructions for all systems installed
- contact details for all manufacturers of products used
- contact details for all installers of the products used
- key components installed
- a completed manufacturer's certificate from an acceptable independent assessment organisation, Benchmark, MCS, electrical safety or suitable alternative
- details of the fuel type and source
- maintenance and servicing requirements
- warranties and/or guarantees for appliances including LZC technology
- customer information on how to use the technologies efficiently and effectively to minimise running costs.



NHBC

Part 9

Finishes





Chapter

9.1



A consistent approach to finishes

This chapter gives guidance on meeting the Technical Requirements for finishes in new homes.

9.1.1	Compliance	02
9.1.2	External walls	02
9.1.3	Internal walls and ceilings	05
9.1.4	Doors and windows	06
9.1.5	Floors	07
9.1.6	Glazing	08
9.1.7	Ceramic, concrete, terrazzo and similar tile finishes	08
9.1.8	Fitted furniture	08
9.1.9	Joint sealants	09
9.1.10	Paint finishes	09
9.1.11	Sanitary ware	09
9.1.12	Other surfaces and finishes	09
9.1.13	Pitched roof coverings	10
9.1.14	Garages	10
9.1.15	External works	10
9.1.16	Further information	10



Figure reference table

Figure Reference Table 9.1

Fig No	Title/Description	Clause	Page
Figure 1	Straightness in plan for fair faced masonry	9.1.2.1	3
Figure 2	Straightness in section for fair faced masonry	9.1.2.1	3
Figure 3	Plumb in section for fair faced masonry	9.1.2.1	3
Figure 4	Straightness at reveals for fair faced masonry	9.1.2.1	3
Figure 5	Straightness of bed joints in fair faced masonry	9.1.2.1	3
Figure 6	Straightness in section for render	9.1.2.2	4
Figure 7	Straightness of internal walls in section	9.1.3.2	5
Figure 8	Plumb of internal walls	9.1.3.2	5
Figure 9	Level and flatness of ceilings	9.1.3.3	5
Figure 10	Tolerances for external corner details	9.1.3.3	6
Figure 11	Tolerances for internal corner details	9.1.3.3	6
Figure 12	Tolerances for boxings	9.1.3.3	6
Figure 13	Tolerances for internal openings	9.1.4	7
Figure 14	Tolerances for windows	9.1.4	7
Figure 15	Tolerances for internal doors	9.1.4	7

9.1.1 Compliance

Also see: Chapter 2.1

Finishes shall comply with the Technical Requirements.

Finishes that comply with the guidance in this chapter will generally be acceptable.

This guidance:

- is intended to apply when the home is substantially complete and ready for NHBC pre-handover inspection
- will be used by NHBC both during the construction process and when conducting resolutions under section 2 of the Buildmark insurance cover
- should be considered in conjunction with relevant performance standards and guidance contained elsewhere within NHBC Standards
- uses tolerances and finishes considered to be appropriate for the house-building industry and takes precedence over other recommendations
- is not intended to deal with every situation which may arise, and discretion should be exercised.

Some elements may be subject to the effects of normal thermal or drying movement, and this may occur both before and after completion.

Some materials are not uniform and are not intended to be; this includes reclaimed materials. Some colour and texture variation is inevitable; this is often used as an aesthetic feature and should be recognised in appropriate tolerances or considered separately. Acceptability of finished appearances will be in the opinion of NHBC.

The nature and extent of work necessary to remedy minor variations from the tolerances and finishes given should be proportionate and appropriate to the circumstances: for example, how readily visible or extensive the affected part of the construction is.

9.1.2 External walls

Also see: Chapter 6.11

External walls shall have an acceptable finished appearance. Issues to be taken into account include:

- | | |
|------------------------|-------------------------|
| 1) fair faced masonry | 5) brick slip cladding |
| 2) render | 6) timber cladding |
| 3) curtain walling | 7) tile hanging |
| 4) rainscreen cladding | 8) cast stone elements. |

Tolerances and appearance should be considered:

- for the entire wall (eg panels and interfaces), and not for the individual elements of the construction, such as individual bricks, individual bed joints, or design features and details (eg quoins, soldier courses and plinths)
- in daylight, and from a minimum distance of 10m.

9.1.2.1 Fair faced masonry

Fair faced masonry should:

- be reasonably uniform in texture, finish and colour, including mortar
- not have excessive colour banding
- not have significant cracks in the facing bricks or other damage, such as chips and marks greater than 15mm in diameter.

Where a fair faced finish can only be achieved on one side (such as half brick walls), the other faces should be left neat and tidy.

Also note:

- some mortar blemishes will occur on individual masonry units
- some variation will occur in the texture, finish and colour of mortar, in individual masonry units and generally over the wall
- efflorescence occurs naturally in some types of masonry; it is not harmful and generally disappears over time
- some brick products have features or marks which may be in excess of 15mm in diameter
- some minor shrinkage cracking may occur between masonry units (bricks and blocks) and mortar joints.

Fair faced masonry should meet the following tolerances:

- adequately straight on plan, with a $\pm 8\text{mm}$ maximum deviation in any length of wall up to 5m
- adequately straight in section, with a tolerance of $\pm 8\text{mm}$ per storey height (up to 3m)
- a maximum of 8mm from plumb in any storey up to 3m (taller walls should be a maximum of 8mm from plumb per storey and 12mm in total)
- a maximum deviation of 4mm over 1m at external reveals.

Figure 1: Straightness in plan for fair faced masonry

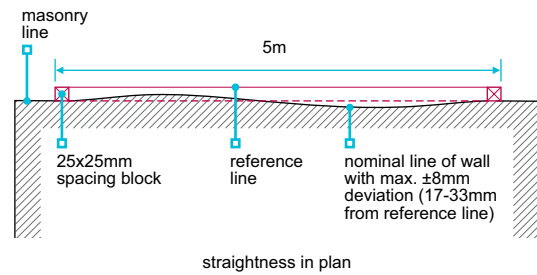

Example:
Using 25mm-wide spacing blocks, the masonry line should be 17-33mm from the reference line.

Spacing block dimensions are a guide, and final dimensions should ensure the reference line is kept clear of the wall face.

Figure 2: Straightness in section for fair faced masonry

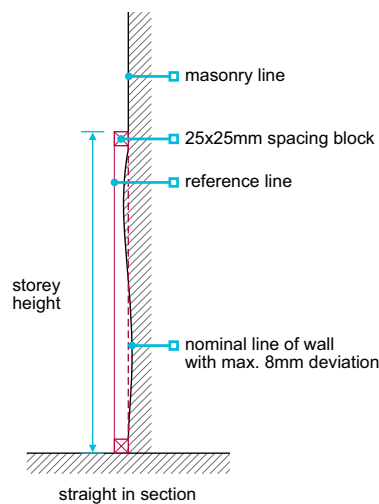

Example:
Using 25mm-wide spacing blocks, the masonry line should be 17-33mm from the reference line.

Spacing block dimensions are a guide, and final dimensions should ensure the reference line is kept clear of the wall face.

Figure 3: Plumb in section for fair faced masonry

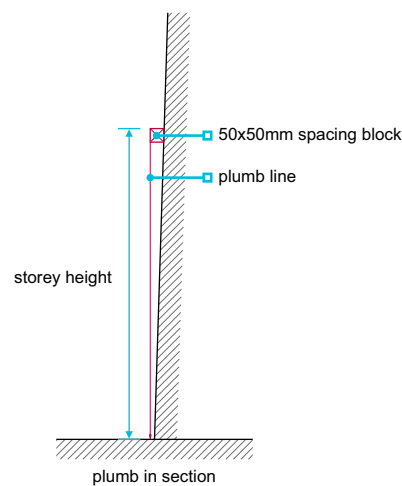

Example:
Using 50mm-wide spacing blocks, the plumb bob should be 42-58mm from the wall, measured at 2.5-3m from the spacing block.

Spacing block dimensions are a guide, and final dimensions should ensure the plumb line is kept clear of the wall face.

Figure 4: Straightness at reveals for fair faced masonry

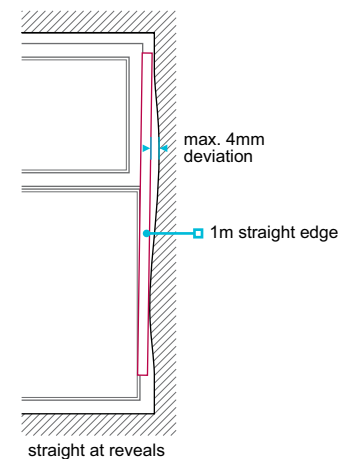

Bed joints should be reasonably straight, measured along the top of a given row of bricks, with:

- a maximum deviation from straightness of $\pm 8\text{mm}$ in any 5m section of wall.

The thickness of an individual bed joint should not vary from the average of the next eight successive joints by a maximum of $\pm 1.5\text{mm}$.

Figure 5: Straightness of bed joints in fair faced masonry

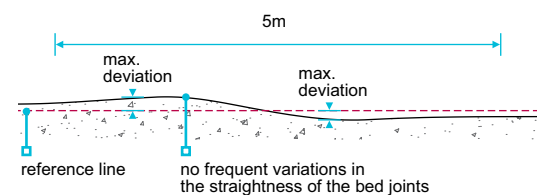

Example of how to determine if bed joint thickness is acceptable

Measure and add 8 successive bed joints and divide by 8 to determine the average size:

$$11+10+12+10+11+9+11+10 = 84$$

$$\text{Divide by } 8 = 10.5\text{mm}$$

Therefore, the acceptable range of the bed joint below the 8 measured bed joints is 9-12mm.

Perpend joints should not cumulatively displace in the same direction for more than 5 joints. The centre line of any perpend joint should generally be within $\pm 15\text{mm}$ of the centre line of the next 5 successive perpend joints.

Also note: to achieve setting out, perp joints in masonry panels between openings may be offset with the perp joints in the panels above and below. The joints within the panel should not cumulatively displace.

9.1.2.2 Render

Render should:

- be reasonably consistent in texture, finish and colour
- be flat, within a maximum $\pm 4\text{mm}$ vertical and horizontal deviation in 5m
- be free from crazing (a set of hairline cracks, generally less than 1mm in depth and no more than 0.2mm wide).

Also note:

- there may be some colour variation in appearance due to differences in suction of the background and orientation of the wall
- daywork joints, patching and other repairs may be visible but should not be unduly obtrusive
- some localised hairline cracking is likely to occur in both traditional render and proprietary render systems. Such cracking and crazing should not impair the performance of the home
- areas of render in close proximity to features (eg bell casts) are excluded from the tolerance
- flatness is measured in a similar way to straightness and plumb of masonry.

Figure 6: Straightness in section for render

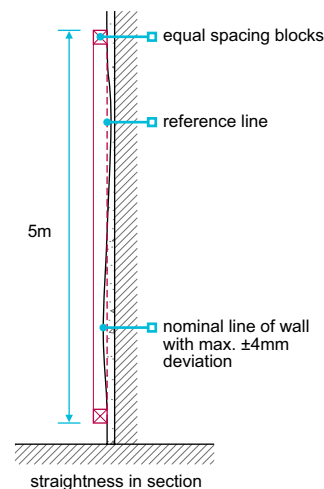

Example:
Using 25mm-wide spacing blocks, the masonry line should be 21-29mm from the reference line.
Spacing block dimensions are a guide, and final dimensions should ensure the plumb line is kept clear of the wall face.

9.1.2.3 Curtain walling

Curtain walling should be within:

- reasonable tolerances and appearance for the materials
- a maximum deviation of $\pm 2\text{mm}$ in any storey height or structural bay width, and $\pm 5\text{mm}$ overall, unless otherwise specified in the design.

9.1.2.4 Rainscreen cladding

Rainscreen cladding should be within:

- reasonable tolerances and appearance for the materials
- a maximum deviation of $\pm 3\text{mm}$ in any storey height or structural bay width, unless otherwise specified in the design.

9.1.2.5 Brick slip cladding

Brick slip cladding should meet the same tolerances as fair faced masonry.

9.1.2.6 Timber cladding

Variation in colour may occur in uncoated timber exposed to the weather, and the rate and extent may vary.

Also note:

- the effects of normal weathering over time may cause uncoated timber to develop a silver/grey colour
- variations in the weathering of uncoated timber cladding may occur as a result of building features such as projecting sills and roof overhangs.

9.1.2.7 Tile hanging

Panels should be reasonably uniform in appearance, particularly at abutments. Tiles should not have significant variations in texture, finish and colour (see Clause 9.1.13).

9.1.2.8 Cast stone elements

Cast stone should be reasonably uniform in both colour and texture.

Also note:

- efflorescence, fungal growth and colour variation may occur due to orientation, shading and pollution
- surface abrasions and chips should be repaired in accordance with the manufacturer's recommendations.

9.1.3 Internal walls and ceilings

Internal walls and ceilings shall be built to appropriate tolerances and have an acceptable finished appearance. Issues to be taken into account include:

- 1) plastering and dry lining
- 2) walls
- 3) ceilings
- 4) skirtings.

9.1.3.1 Plastering and dry lining

Plastered and dry lined surfaces should:

- not have board joints readily visible and be within a maximum $\pm 3\text{mm}$ deviation, measured using a 450mm straight edge with equal offsets
- be viewed from a distance of 2m in natural daylight with no artificial light shining on the surface (wall lights and/or uplighters should be switched off).

9.1.3.2 Walls

Walls should:

- be reasonably uniform, although there may be minor textural differences around lights and other fittings
- have no visible gaps between fittings and the surface (eg around switch plates)
- have jointing tape fully covered and unobtrusive in the finished surface
- have flat walls and within a $\pm 3\text{mm}$ deviation measured using a 2m straight edge with equal offsets
- be a maximum of 8mm from plumb for walls up to 3m high (taller walls should be a maximum of 8mm from plumb per storey and 12mm in total).

Figure 7: Straightness of internal walls in section

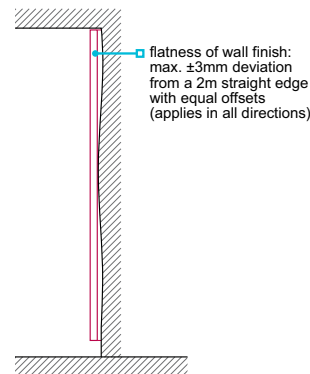
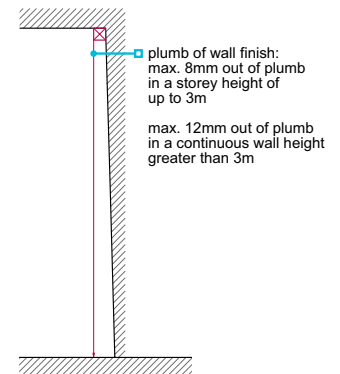

Figure 8: Plumb of internal walls



9.1.3.3 Ceilings

Ceilings should be:

- level within a 3mm deviation per 1m for ceilings up to 6m across (measured at the furthest points across the full width of the ceiling)
- a maximum of 20mm out of level for ceilings over 6m across
- flat within a $\pm 5\text{mm}$ deviation, measured using a 2m straight edge with equal offsets.

Figure 9: Level and flatness of ceilings

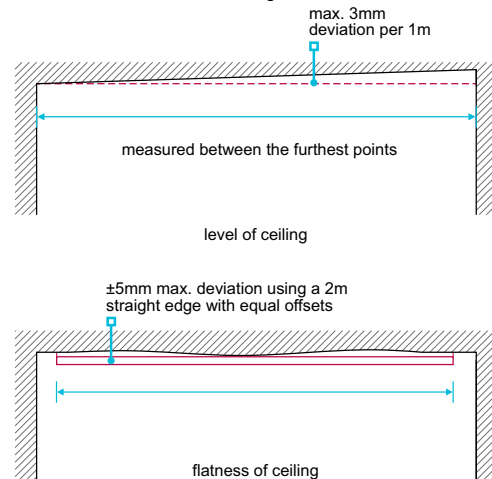

Setting out of corners, duct casings, access covers and any associated framing should be:

- square
- neat and tidy
- provided with an appropriate decorative finish.

Figure 10: Tolerances for external corner details

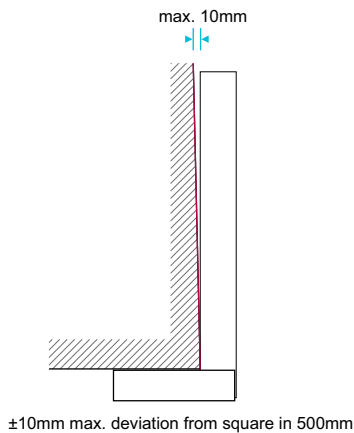

Figure 11: Tolerances for internal corner details

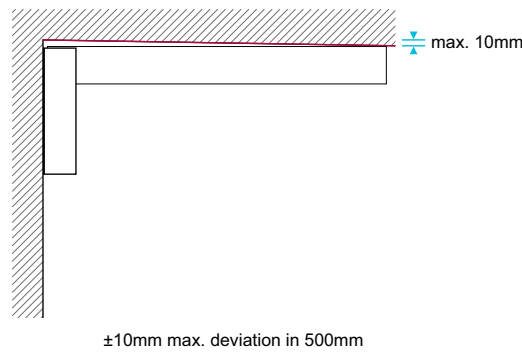
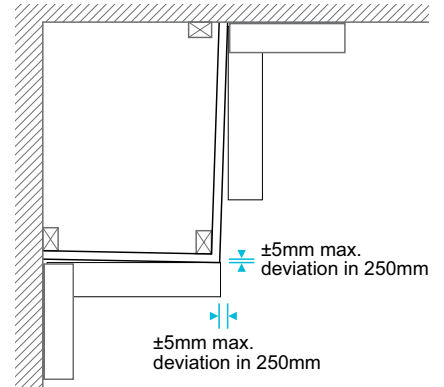

Figure 12: Tolerances for boxings



Also note:

- in plastered walls and ceilings, some tooling marks may be visible
- some cracking (up to 2mm wide) may occur at wall, floor and ceiling junctions, due to shrinkage and differential movement of materials
- small cracks may occur in wall finishes which pass across floors (eg in staircase walls)
- where stair strings abut a wall, a crack of up to 4mm may appear as a result of shrinkage of materials.

9.1.3.4 Skirtings

Where skirtings are installed:

- the gap between the floor finish (without coverings) and the bottom of the skirting should not exceed 5mm at the time of completion
- joints should present a continuous appearance when viewed from a distance of 2m in daylight (some initial shrinkage of the skirting may already be evident at completion of the property).

Also note:

- the gap between the floor finish and the skirting may increase due to normal drying out, shrinkage and/or deflection, particularly in timber floors
- gaps may appear at joints and corners due to shrinkage, and between the wall finish and skirting due to drying out, shrinkage and fixing position.

9.1.4 Doors and windows

Doors and windows shall be installed to appropriate tolerances, including openings in walls and external openings viewed from the inside.

Internal openings in walls should:

- be flat along the length of sills and window boards, with a maximum deviation of $\pm 3\text{mm}$ in every 2m
- have level heads and sills, a maximum of 3mm from level for openings up to 1.5m, and 5mm where longer
- have plumb reveals, a maximum of 3mm from plumb for openings up to 1.5m high, and 5mm where higher
- be level within 3mm across the sill measured from the frame (tiled sills, in bathrooms, for example, may be intentionally laid sloping away from the window)
- be square with the window, with a maximum deviation of $\pm 5\text{mm}$ for reveals up to 250mm deep.

Window frames should not be distorted in the opening, and a maximum from plumb of:

- 3mm when up to 1.5m in height
- 5mm when larger.

Figure 13: Tolerances for internal openings

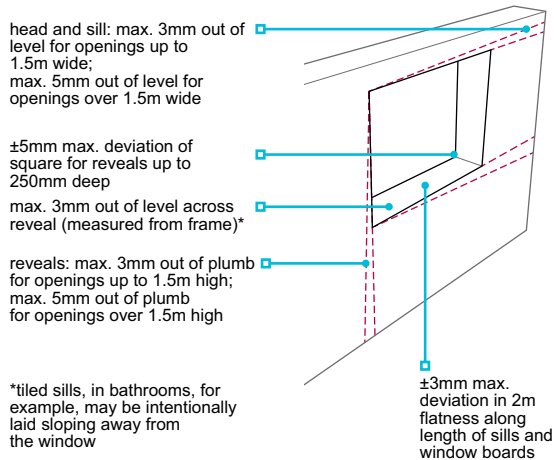
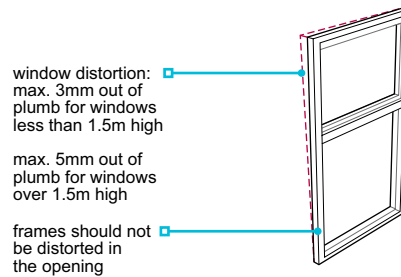

Figure 14: Tolerances for windows



Internal doors

Internal doors and frames should always be installed in accordance with the manufacturer's recommendations, not be distorted in the opening, and:

- frames should be within 5mm of plumb over the height of the frame and not out of plumb in two directions
- the gap between the door and head or jamb should be a maximum of 4mm (for double doors, the gap at the meeting stiles should be within 4mm) and uniform
- distortion across doors should be limited to a maximum of 5mm in height, and 3mm in width
- the gap between the underside of the door and unfinished floor should be between 10mm and 22mm, with the ventilation requirements for the building taken into account when determining the gap beneath internal doors.

Figure 15: Tolerances for internal doors

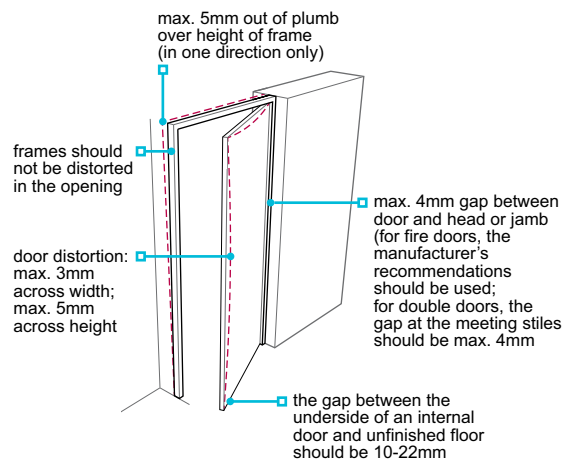

The max. gap should not exceed 22mm, however, homeowners will need to choose a covering to suit or adjust the door height accordingly.

In England and Wales, where the builder provides a floor finish there should be a gap of 10mm between the bottom of the door and floor finish (for a 760mm wide door).

The dimensions are without prejudice to satisfactory performance in terms of weathertightness, draught exclusion and fire resistance.

Fire doors

Fire doors should be installed in accordance with the manufacturer's recommendations. The tolerances in this clause are without prejudice to satisfactory performance for ventilation and fire resistance.

External doors

External doors and frames should be installed in accordance with the manufacturer's recommendations, not be distorted in the opening, and:

- frames should be within 5mm of plumb over the height of the frame and not be out of plumb in two directions
- distortion across the door should be limited to a maximum of 5mm in height and 3mm in width.

9.1.5 Floors

Floors shall be built to appropriate tolerances.

Floors should be:

- level within a 3mm deviation per 1m for floors up to 6m across (measured at the furthest points across the full width of the floor)
- a maximum of 20mm out of level for floors over 6m across
- flat within a ±5mm deviation, measured using a 2m straight edge with equal offsets.

Underfloor service ducts should be constructed so that the cover is level with the adjacent floor finish. The selection of floor finish should take into account that drying shrinkage of the floor may result in minor differences in level between the floor and duct cover, which may be more evident with some types of thin floor coverings.

9.1.6 Glazing

Glass shall be free from undue defects.

Glass should be checked in daylight, from within the room and from a minimum distance of 2m (3m for toughened, laminated or coated glass). The following are acceptable where they are not obtrusive or bunched:

- bubbles or blisters
- fine scratches not more than 25mm long
- hairlines or blobs
- minute particles.

The above does not apply to areas within 6mm of the edge of the pane, where minor scratching may occur.

9.1.7 Ceramic, concrete, terrazzo and similar tile finishes

Ceramic, concrete, terrazzo and similar tile finishes shall have an appropriate appearance.

For ceramic, concrete, terrazzo and similar tile finishes:

- joints should be straight and in alignment, unless the tiles are, by design, irregular in shape
- wall tile joints should be a minimum of 1.5mm for ceramic tiles, 2mm for smooth natural stone tiles and 6mm for textured tiles, unless otherwise specified by the manufacturer
- floor tile joints should be a minimum of 3mm and proportionally wider for larger tiles, unless otherwise specified by the manufacturer
- joints in floor tiles should generally not exceed the tile thickness, although wider joints up to 10mm may be necessary to accommodate dimensional irregularities in some tiles
- joints should limit the effect of dimensional irregularities, and be suitably arranged to maintain a regular appearance
- the variation in surface level should be within $\pm 3\text{mm}$ measured using a 2m straight edge with equal offsets
- the variation in surface level between adjacent tiles should be 1mm or less where the joint is up to 6mm wide, or 2mm or less where the joint is over 6mm wide.

9.1.8 Fitted furniture

Fitted furniture shall have an appropriate appearance.

Fitted furniture, including doors and drawers, should:

- be visually aligned (vertically, horizontally and in plan), and there should not be significant differences in level at the intersection of adjacent worktops
- operate as intended by the manufacturer
- have uniform gaps between adjacent doors and/or drawers where appropriate
- not have conspicuous abrasions or scratches on factory-finished components when viewed in daylight from a distance of 0.5m.

Also note:

- no dimensional tolerance has been set for gaps between adjacent doors and/or drawers or for their alignment, because some variation will be necessary to take account of adjustments as part of the fitting process
- no dimensional tolerance has been set for the abutment of adjacent worktops, due to the variety of materials available and because minor variations, even with manufactured products, are inevitable and small differences in height may be unavoidable
- fitted furniture should be viewed from a distance of 0.5m
- conspicuous surface abrasions caused during installation should be removed in accordance with the manufacturer's recommendations, which may include filling, polishing out, respraying or painting as appropriate
- in rooms or areas where there is no daylight, scratches should be viewed in artificial light from fixed wall or ceiling outlets and not from portable equipment
- kitchen units should not delaminate, including those located near hobs and extractor fans.

9.1.9 Joint sealants

Joint sealants shall have a neat and tidy appearance.

Sealants should be tooled to:

- remove blisters and irregularities
- achieve a compact, smooth neat surface finish.

Also note:

- joints should be viewed from a distance of 2m, where possible, depending on the location (eg showers and baths may make this impossible).

9.1.10 Paint finishes

Painted and varnished surfaces shall be even in appearance and free from conspicuous runs and prominent brush marks.

Painted and varnished surfaces should:

- be reasonably smooth and free from nail holes, cracks and splits
- have joints filled
- be reasonably uniform in colour, texture and finish.

Also note:

- surfaces should be viewed in daylight from a distance of 2m and not by shining artificial light on the surface. Wall lights and/or uplighters should be switched off
- timber surfaces may show limited raised grain, and the colour and texture may also vary
- drying shrinkage of timber may cause cracking of the paint finish, particularly where joints occur in plaster and woodwork
- where painted surfaces are touched up, minor colour variations may occur
- external finishes will dull over time, depending on a number of factors such as exposure to sunlight, rain and pollutants
- resin can exude from knots, causing discoloration of paintwork, even though modern primers contain a compound to limit this
- site-decorated trim, such as architrave and skirting, may have a different finished appearance from factory-finished components, such as doors.

9.1.11 Sanitary ware

Baths, shower trays and basins shall be free from scratches, chips and other damage at the time of handover.

Sanitary fittings, such as baths, shower trays and basins, should not have conspicuous abrasions, scratches or chips when viewed in daylight from a distance of 0.5m.

Also note: in rooms or areas where there is no daylight, scratches should be viewed in artificial light from fixed wall or ceiling outlets and not from portable equipment.

9.1.12 Other surfaces and finishes

Other surfaces and finishes shall have an appropriate appearance.

Other surfaces and finishes, such as fascia boards, meter cabinets and radiators, should:

- be reasonably smooth and free from nail holes, cracks and splits
- have joints filled
- be reasonably uniform in colour, texture and finish.

9.1.13 Pitched roof coverings

Pitched roof coverings shall have an acceptable finished appearance.

Tiles and slates should:

- be reasonably uniform in texture, finish and colour
- be suitably mixed to avoid excessive colour banding.

Also note:

- some minor blemishes will occur on individual tiles and slates
- some minor variations will occur in the texture, finish and colour of individual tiles and slates
- efflorescence occurs naturally on some types of tile. It is not harmful and generally disappears over time. Tiles which have efflorescence when laid should be suitably mixed to avoid a patchy appearance.

9.1.14 Garages

Garages shall have an acceptable appearance.

Garage walls, floors and roofs should be built to appropriate tolerances.

Also note:

- cracks up to 2mm wide in unplastered blockwork walls may be evident due to thermal movement and shrinkage
- garage floors may be installed with falls for drainage or fire separation. Where garage floors have not been sealed, dusting may occur
- the effects of normal drying shrinkage of concrete floors could cause some small gaps around the perimeter at wall junctions.

9.1.15 External works

External works, including drives and paths, shall have appropriate finishes.

Drives and paths should be:

- within a maximum ± 10 mm deviation measured using a 2m straight edge with equal offsets; however, localised falls into gulleys and channels are acceptable
- designed and constructed to minimise the potential for standing water.

One hour after rain has stopped, areas of temporary standing water should not be deeper than 5mm or exceed 1m². Temporary standing water is not permitted adjacent to entrance doors.

Also note:

- displacement and variations in surface levels, including scuffing and pitting, may arise due to settlement, natural ground movement and traffic
- when checking flatness, the slope required for drainage on drives should be taken into account.

Drainage covers should:

- align with the adjacent ground or surface finish (for channels, the cover should be set below the adjacent ground)
- be positioned so that the difference in height between the cover and adjacent hard surfaces allows for future settlement.

9.1.16 Further information

- *Roof Tile Association Guidance — A developer and contractor guide to achieving the best visual effect with roof tiles manufactured from concrete and clay. Issue 1: August 2023*



Chapter 9.2



Wall and ceiling finishes

This chapter gives guidance on meeting the Technical Requirements for internal wall and ceiling finishes.

9.2.1	Compliance	02
9.2.2	Provision of information	02
9.2.3	Plastering	02
9.2.4	Dry lining	04
9.2.5	Ceramic wall tiling	07
9.2.6	Further information	09



Figure reference table**Figure Reference Table 9.2**

Fig No	Title/Description	Clause	Page
Figure 1	Nogging and board arrangements where two layers of plasterboard are installed to ceilings	9.2.4.3	5

9.2.1 Compliance

Also see: Chapter 2.1

Wall and ceiling finishes shall comply with the Technical Requirements.

Wall and ceiling finishes that comply with the guidance in this chapter will generally be acceptable.

9.2.2 Provision of information

Designs and specifications shall be produced in a clearly understandable format, include all relevant information and be distributed to the appropriate personnel.

Designs and specifications should be issued to site supervisors, relevant specialist subcontractors and suppliers, and include the following information:

- schedule of finishes
- plaster thickness, mix and special requirements
- installation details of air and vapour control layers (AVCL) behind dry lining
- fixing specification
- extent and detail of tiled surfaces
- location of services adjacent to tiled surfaces.

9.2.3 Plastering

Also see: Chapter 8.1, BS 8000-0

Plastering shall provide an adequate substrate for the decorative finish.

The design, preparation and application of plasters should be in accordance with BS EN 13914-2 and BS 8481. Materials for plastering should be in accordance with BS 8481 and those listed in Table 1.

Where plaster is intended to contribute to fire resistance or sound insulation, overall performance should be in accordance with the Building Regulations.

Table 1: Materials for use in plastering

Plasters	BS EN 13279	Gypsum binders and gypsum plasters. Definitions and requirements
	BS 5270-1	Bonding agents for use with gypsum plasters and cement. Specification for polyvinyl acetate (PVAC) emulsion bonding agents for indoor use with gypsum building plasters
Metal laths and beads	BS EN 13658-1	Metal lath and beads. Definitions, requirements and test methods — Internal plastering
	BS EN 13658-2	Metal lath and beads. Definitions, requirements and test methods — External rendering

The background should be:

- given an appropriate treatment before plastering, in accordance with BS EN 13914-2 and BS 8481
- suitably finished to provide an adequate key
- checked to ensure adequate and even suction
- sufficiently even to provide a reasonably flat plaster finish (excessive ‘dubbing out’ should be avoided).

Mixed background materials and associated differential movement can lead to cracks and should be avoided. Suitable precautions should be taken, eg using metal lathing.

Metal beads should be used to provide edge protection and be fixed with zinc-plated fasteners, as recommended by the manufacturer.

Table 2: Recommended treatments for substrates

Surface	Treatment
High-density clay, concrete or calcium silicate bricks and blocks and dense concrete (including soffits)	Depending on suction and bond; may require use of a spatterdash pre-treatment or bond with polymer-modified cement mortar or metal lathing
Lightweight clay block	The suction should be checked to ensure that it is similar to that of normal clay bricks. If not, special precautions may be necessary
Mixed backgrounds, eg concrete with bricks/blocks	In accordance with BS EN 13914-2. May require either a carrier system or reinforced undercoat to reduce the effect of differential movement
Lightweight concrete blocks	A polymer-modified spatterdash or bonding agent is recommended, depending on the plaster and the smoothness and suction of the blockwork
Autoclaved aerated concrete blocks	Plastering should be conducted in accordance with the manufacturer's recommendations, accounting for the moisture content of the blocks. Depending on the absorption characteristics, the use of a suction reducing treatment may be required
Normal clay brickwork	May require raked joints or the use of keyed bricks
Concrete and calcium silicate brick — or blockwork	Dependent on the suction and bond, may require use of a spatterdash pre-treatment or metal lathing
Plasterboard	Guidance is contained in BS 8000-8

Where services are to be concealed by plaster, they should be:

- completed and tested before plastering
- protected against the adverse effects of chemical action or thermal movement.

At localised areas, to avoid surface cracking, metal lathing or wire netting should be used where there is an insufficient depth of plaster.

The plaster mix should be:

- as specified, or as recommended by the plaster manufacturer for the particular location and use
- appropriate for the strength and surface characteristics of the background
- an appropriate quality for the intended finish
- checked to ensure undercoats and finishing coats are compatible
- applied by suitably trained operatives (specifically where plastic compound finishes are used)
- of a type that does not include Portland cement and gypsum plaster in the same mix.

When plastering:

- completed work, especially timber, chipboard and glazing, should be protected from damp and damage
- in cold weather, follow the guidance in Chapter 3.2 Cold weather working (plasterwork damaged by frost should be removed and replaced)
- dubbing out should be conducted well in advance of the application of the first coat
- surfaces should be dry, clean and free from laitance, grease, loose material or substances likely to prove harmful to the bond or the intended finished appearance of the plaster
- ensure plaster is thoroughly mixed but avoid prolonged mixing
- avoid mixing excessive quantities of plaster (plaster should not be retempered)
- the background surface of each coat should be fully set (the surface should not be overworked, and adequate time should be left between coats to allow strength and suction to develop)
- the number of coats should be sufficient to achieve a reasonably plane finish
- finished surfaces, reveals, soffits to openings, external angles, etc should be in accordance with Chapter 9.1 A consistent approach to finishes
- the plaster should be applied to a thickness, excluding dubbing out, in accordance with Table 3.

Table 3: Plaster thickness

	Surface to be plastered	Minimum number of coats	Thickness of plaster
Walls	Metal lathing	3	13mm (nominal from lathing)
	Brickwork	2	13mm maximum
	Blockwork	2	13mm maximum
	Plasterboard or concrete	1	Sufficient to provide a crack-free surface
Ceilings	Concrete	2	10mm maximum
	Plasterboard	1	Skim coat

9.2.4 Dry lining

Also see: BS 8000-8, BS EN 520

Dry lining shall provide an adequate substrate for the decorative finish. Issues to be taken into account include:

- | | |
|----------------------------------|--------------------------|
| 1) installation | 3) detailing and support |
| 2) air and vapour control (AVCL) | 4) fixing. |

9.2.4.1 Installation

Dry lining should:

- not be started until the building is substantially weatherproofed
- not be started until structural timber components are at a moisture content of 20% or less
- be programmed so that finishes are applied as soon as possible after completion
- provide performance in accordance with Building Regulations where it contributes to fire resistance
- ensure that gap sealing is specified where necessary to prevent draughts.

Table 4: Standards relevant to dry lining

BS EN 520	Gypsum plasterboards. Definitions, requirements and test methods
BS 8000-8	Workmanship on construction sites — Design and installation of dry lining systems. Code of practice

9.2.4.2 Air and vapour control (AVCL)

Air and vapour control layers should be used to reduce the risk of interstitial condensation and enhance airtightness, and be installed in accordance with:

- Chapter 6.2 External timber framed walls
- Chapter 6.10 Light steel framed walls and floors
- Chapter 7.1 Flat roofs, terraces and balconies
- Chapter 7.2 Pitched roofs.

9.2.4.3 Detailing and support

Support should be provided to plasterboard walls and ceilings in accordance with Tables 5 and 6. Where walls are to receive ceramic tiling, additional support may be required (see Table 10).

Table 5: Frequency of support for plasterboard to walls

Board thickness (mm)	Maximum timber support centres (mm) ⁽¹⁾
9.5	450
12.5, 15 and 19	600

Table 6: Frequency of support for plasterboard to ceilings

Board thickness (mm)	Maximum timber support centres (mm)	Intermediate noggings required ⁽¹⁾	Perimeter noggings required ⁽¹⁾
9.5	400	No	Yes
	450	Yes	Yes
12.5 and 15	400	No	Yes
	450	No	Yes
	600	Yes	Yes
19	600	No	No

Note

1. Alternatively, the spacing of studs and joists, the requirements for intermediate and perimeter noggings, and any additional support battens should be in accordance with the plasterboard or system manufacturer's installation instructions, fire test evidence, or applicable industry guidance documents.

When fixing boards:

- damaged boards should not be used
- they should be fixed face side out, appropriate for plastering or directly applied finishes
- cut edges should finish over a support or nogging (though they are permitted, where necessary, at perimeters)
- there should be adequate support for light points, socket outlets and other service installations
- openings for services and electrical outlets should be accurately cut (gaps in the air and vapour control layers should be taped and sealed)
- ceiling boards should be staggered to minimise any risk of cracking
- where metal resilient bars are installed to ceilings, additional resilient bar perimeter noggings should be installed in accordance with the manufacturer's installation instructions and/or supporting fire test evidence.

Joints between boards should be neatly formed, flush and suitably finished:

- with scrim tape or paper tape, where boards are to be plastered
- with tape, and filled, where boards are not to be plastered (tapered edge boards should be used for directly applied finishes), or
- as recommended by the manufacturer.

Where double layers of plasterboard are used, they should:

- be positioned so joints are staggered between layers
- have the first layer fully fixed and have all cut edges supported
- have the second layer supported on all edges with noggings provided to suit.

Figure 1: Nogging and board arrangements where two layers of plasterboard are installed to ceilings

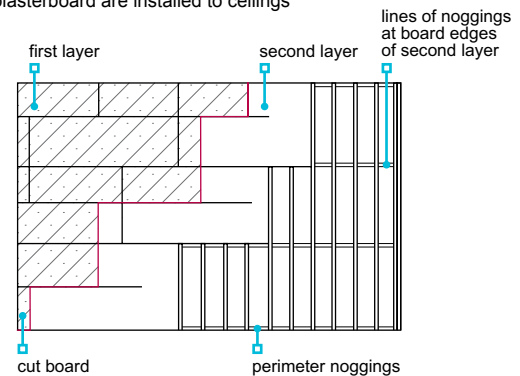

Dry lining should be:

- completely taped and filled at board joints and at the abutments to ceilings and internal walls
- finished to an appropriate standard and in accordance with Chapter 9.1 A consistent approach to finishes.

9.2.4.4 Fixing

Plasterboard should be fixed to:

- timber using dry wall screws
- metal using dry wall screws, or
- masonry using adhesive dabs.

Where insulated dry lining is used, nailable plugs should be specified in accordance with the manufacturer's recommendations, and at a minimum of two per board.

Screws should not project above the board surface and should be:

- 10mm minimum from paper-bound edges
- 13mm minimum from cut ends of boards
- 6mm minimum from edges of timber members.

Table 7: Acceptable fixing centres

Fixing	Location and spacing ⁽¹⁾	Coating
Screw	<p>Ceilings: approximately 230mm centres (eight per two linear metres) within the field of the plasterboard, and 150mm at plasterboard ends and ceiling perimeters</p> <p>Walls: approximately 300mm centres (five per linear metre), and 200mm on external corners and around openings</p>	Zinc electroplated or black phosphate (or to the board manufacturer's recommendations)

Table 8: Acceptable fixing lengths

Board thickness (mm)	Screw length (mm) into timber ⁽¹⁾	Screw length (mm) into steel ⁽¹⁾
9.5	35	25
12.5	38	25
15	40	25
2 x 12.5	50	35
2 x 15	60	40
1 x 12.5 and 1 x 19	57	42

Note
1. Alternatively, the spacing, length and type of fixings should be in accordance with the plasterboard or system manufacturer's installation instructions, fire test evidence, or applicable industry guidance documents.

Where dry lining is fixed with adhesive dabs, it should be:

- securely fixed and filled at external and internal corners, including door and window openings
- filled with jointing compound where required, at gaps around service points, electric sockets, light switches, etc
- installed with a continuous ribbon of adhesive to the perimeter of external walls, and around openings and services, to prevent air infiltration.

Adhesive dabs should be at 300mm centres measured vertically; each dab should be 50mm to 75mm wide and approximately 250mm long, and in accordance with Table 9.

Table 9: Dabs according to board dimensions

Thickness of wall board (mm)	Width of wall board (mm)	Vertical rows of dabs per board
9.5	1,200	4
12.5	1,200	3
15.0	1,200	3

Dry lining to receive ceramic wall tiling should be supported in accordance with Table 10 or the guidance given in BS 8000-8.

Table 10: Board fixing guidance for walls to receive ceramic tiles

Description	Board thickness (mm)	Support centres (mm)	Additional support	Maximum height (mm)	Comments
Timber frame (including stud walling)	12.5, 15	400-450	No	3,600	
		600	Timber noggings 600mm centres (measured vertically)	3,600	
Timber battens	12.5, 15	400	Battens at head, base and intermediate positions not exceeding 1200mm centres	3,600	
Direct bond	9.5	400 dabs of adhesive in rows	Horizontal dabs at 1/3 centres in height	3,600	Complete at least 10 days before tiling
Independent steel stud lining, 48mm or 60mm	2 x 12.5	400	Mid-point support	3,000	
48mm metal stud partitions	15 2 x 12.5 each side, or 2 x 15 each side	400	Additional stud at 300mm up to tile height	2,700	
		400		3,600	
70mm metal stud partitions	15 2 x 12.5 each side, or 2 x 15 each side	400		3,600	
		400		3,600	
146mm metal stud partitions	2 x 15 each side	600		3,600	

9.2.5 Ceramic wall tiling

Also see: Clause 9.2.4 and Tile Association Guides

Ceramic wall tiling shall provide a surface adequate for its location and intended use (including appearance and durability).

Ceramic tiling and backing surfaces to walls should be in accordance with BS 5385.

Where a fixed shower or showerhead fixing is provided over a bath, at a height that will permit persons to stand under it:

- a screen or other suitable means of containing the water should be provided
- surfaces which will become regularly wetted should be tiled or have an appropriate alternative water-resistant finish.

Backing surfaces for tiling should:

- be in accordance with Tables 10 and 11
- be strong enough to support the weight of the adhesive and tiling (where separate coats are used, they should be well bonded)
- be completed at least 10 days before wall tiling takes place where dry lining is fixed with dabs of adhesive
- provide an adequate mechanical key
- be sufficiently flat to achieve an even and plane tiled surface
- provide adequate and consistent suction
- be rigid and stable to avoid differential movement; where this may occur, precautions should be taken, eg metal lathing or wire netting fixed across junctions
- be dry, clean and free from laitance, grease, loose material or any substance likely to affect the bond or finish
- be reasonably even (ie, +/-3mm when using a 2m straight edge).

Guidance on suitable backing surfaces for tiling and the use of proprietary intermediate waterproofing layers (tanking systems) can be found in Table 11 below.

Table 11: Suitable backing surfaces for wall tiling

Conditions	Example location	Acceptable backing surface	Intermediate waterproofing layer (tanking system) required	Additional requirements
Installations in normal internal conditions	Walls which do not form part of a bath or shower enclosure, or wet room	Cement rendering, masonry, gypsum plaster, plasterboard, etc	No	None
Installations not immersed but subject to occasional wetting	Domestic (not power) shower and bath enclosures	Water-resistant materials (ie, sand and cement mortar or rendering, concrete, etc)	No	Tiles solidly bedded on water-resistant adhesive Water-resistant grout if tanking is not used
		Proprietary tile backing boards Moisture-resistant plasterboard (Type H)	Refer to TGN 9.2/06	
Installations not immersed but subject to frequent wetting	Wet rooms, domestic power shower enclosures, communal showers, swimming pool halls	Water-resistant materials (ie, sand and cement mortar or rendering, concrete, etc)	Yes	Tiles solidly bedded on water-resistant adhesive
		Proprietary tile backing boards (fibre-reinforced gypsum tile backer boards subject to assessment)	Yes (unless the board manufacturer can demonstrate the board is inherently watertight)	
Installations in high-humidity areas	Areas with constant high humidity (eg saunas and steam rooms)	Water-resistant materials (ie, cement mortar, screed or rendering)	No	Tiles solidly bedded on water-resistant adhesive Water-resistant grout
		Proprietary tile backing boards (fibre-reinforced gypsum tile backing boards subject to assessment)	Yes (unless the board manufacturer can demonstrate the board is inherently watertight)	

Where the backing surface contains soluble salts, and where cement mortar is used as an adhesive, precautions should be taken, such as the use of mortar with cements which resist sulfates.

Gypsum-based materials should not be used where repeated or persistent heating occurs, eg on flues or near heat sources.

Backgrounds may be improved by:

- raking out masonry joints
- hacking and scratching
- applying a bonding agent (particularly on very smooth and dense surfaces).

Tiles should be appropriate for their location and intended use. When specifying tiles, consideration should be given to:

- surface finish
- size and thickness
- colour
- edge shape
- fittings (coves, skirtings, etc)
- accessories (soap tray, paper holder, hooks, etc).

Tiles should be:

- fixed in accordance with manufacturers' instructions
- suitable for the location, intended use and background; their weight on lightweight plaster should not exceed 20kg/m²
- fixed according to the background, using cement mortar or proprietary adhesive
- solidly bedded where their surface area is greater than 0.1m² or where their weight exceeds 70% of the background's capacity to carry the weight.

Table 12: Standards for tiling

BS EN 14411	Ceramic tiles. Definition, classification, characteristics, assessment and verification of constancy of performance and marking
BS EN 12004	Adhesives for ceramic tiles. Test methods
BS EN 13888	Grouts for tiles. Requirements, evaluation of conformity, classification and labelling
BS 5385 - 1	Wall and floor tiling. Design and installation of ceramic, natural stone and mosaic wall tiling in normal internal conditions. Code of practice
BS 5385 - 4	Design and installation of ceramic and mosaic tiling in specific conditions — Code of practice

When tiling:

- courses should be straight and even to form a plane and regular surface, especially around fittings and fixtures
- there should be no cut or unfinished tiles at exposed edges or external corners
- joints should be even and cut neatly
- spacing should be sufficient to allow for expansion
- up to sanitary fittings and fixings, the sealing method should be in accordance with the design and account for movement
- proprietary water-resistant grouting should be used in accordance with the manufacturer's recommendations.

Appropriately designed movement joints should be:

- built into tiling at 3m to 4.5m centres vertically and horizontally
- provided at vertical internal corners in large tiled areas
- located at junctions where there are variations in surfaces or backgrounds
- provided where the tiles abut other materials
- minimum 2mm where tiles are without spacer lugs.

Grouting should be:

- as specified in the design, including mix and colour
- cement-based epoxy resin or a proprietary product.

9.2.6 Further information

- *BS 8000-0:2014 Workmanship on construction sites — Introduction and general principles*
- *BS 8000-8:2023 Workmanship on construction sites — Design and installation of dry lining systems. Code of practice*
- *BS 8000-11:2011 Workmanship on building sites — Internal and external wall and floor tiling. Ceramic and agglomerated stone tiles, natural stone and terrazzo tiles and slabs, and mosaics. Code of practice*
- *BS EN 520:2004+A1:2009 Gypsum plasterboards. Definitions, requirements and test methods*
- *The Tile Association — Internal ceramic tiling to sheet and board substrates. 2003 Edition*
- *The Tile Association — Tiling in wet rooms and showers. February 2022*
- *The Tile Association — Technical Advice Note 6 — The fixing of ceramic wall tiles to gypsum plaster surfaces on masonry backgrounds. January 2022*



Chapter 9.3



Floor finishes

This chapter gives guidance on meeting the Technical Requirements for floor finishes, including:

- integral insulation
- screeds
- ceramic, concrete and similar tiles
- flexible sheet and tiles
- woodblock
- asphalt.

9.3.1	Compliance	02
9.3.2	Provision of information	02
9.3.3	Insulation	02
9.3.4	Screed	02
9.3.5	Ceramic, concrete, terrazzo and similar tile finishes	04
9.3.6	Wood finishes	06
9.3.7	Flexible sheet and flexible tile finishes	08
9.3.8	Asphalt finishes	09
9.3.9	Staircase finishes	09
9.3.10	Further information	09

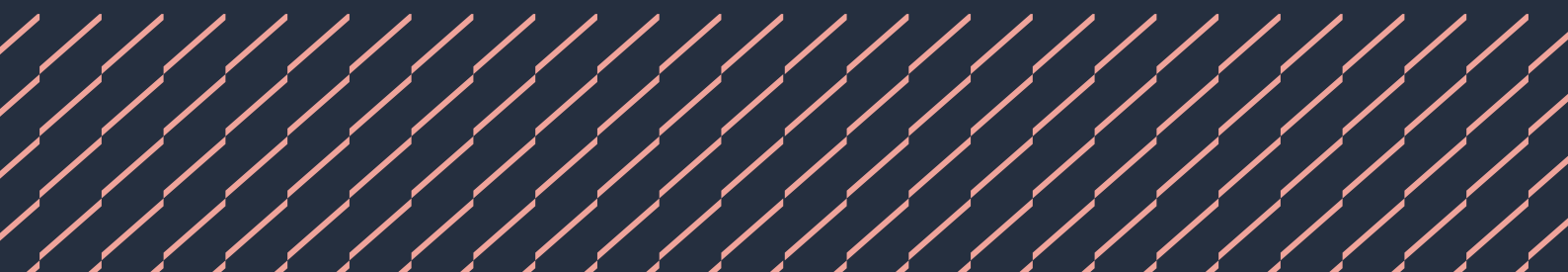

Figure reference table**Figure Reference Table 9.3**

Fig No	Title/Description	Clause	Page
Figure 1	Screeed over insulation	9.3.4.3	4
Figure 2	Location of DPM and insulation on ground-bearing slab	9.3.6.1	7
Figure 3	Location of DPM, VCL and insulation on precast floor	9.3.6.1	7

9.3.1 Compliance

Also see: Chapters 2.1, 5.1, 5.2, 6.4 and 8.1

Floor finishes shall comply with the Technical Requirements.

Floor finishes which comply with the guidance in this chapter will generally be acceptable (structural floors should be in accordance with the relevant Standards Chapters 5.1 Substructure and ground bearing floors, 5.2 Suspended ground floors, 6.4 Timber and concrete upper floors and 6.10 Light steel framed walls and floors).

9.3.2 Provision of information

Designs and specifications shall be produced in a clearly understandable format, include all relevant information and be distributed to the appropriate personnel.

Designs and specifications should be issued to site supervisors, relevant specialist subcontractors and suppliers, and include the following information:

- schedule of finishes
- screed thickness and mix
- details of sound insulating floors
- extent and detail of tiled surfaces
- location of services adjacent to tiled surfaces
- details of staircase finishes.

9.3.3 Insulation

Thermal and acoustic insulation shall provide appropriate performance, and be suitable for the intended location and use.

Materials and constructions which are in accordance with Building Regulations are generally acceptable.

Suitable sound insulation materials include:

- flexible material
- mineral fibre quilt insulation
- board material for use under screeds (eg EPS SD grade expanded polystyrene)
- proprietary products which have been assessed in accordance with Technical Requirement R3.

Table 1: Thermal insulation materials

Material	Standard	Grade or description
EPS (expanded polystyrene)	BS EN 13163	70
PUR (rigid polyurethane)	BS 4841	For use under screeds
PIR (rigid polyisocyanurate)		
Fibre building board	BS EN 622	Insulating board (softboard)
Proprietary material	Technical Requirement R3	

9.3.4 Screed

Also see: Chapters 3.2 and 8.1

Non-structural floor screeds shall be adequate for the location and intended use, and provide a suitable background for floor finishes. Issues to be taken into account include:

- 1) installation
- 2) non-structural screed thickness
- 3) screed over insulation.

9.3.4.1 Installation

Before screeding, background surfaces should be:

- clean and free of debris (eg dust and gypsum removed); concrete should be wetted and brushed
- suitably prepared to provide an adequate mechanical key; where bonded screeds are required, cement grouting or a bonding agent should be specified to provide adequate adhesion.

Damp proofing should be completed before screeding starts.

Screeding should not take place in weather conditions which could adversely affect the finished construction, and:

- should be scheduled to allow suitable drying time before following trades
- in hot or dry weather, precautions should be taken to prevent the screed surface drying out too quickly
- in cold weather, screeds should not be installed (screed damaged by cold should be removed and replaced).

Non-structural screed should be:

- installed to the specified thickness and provide an even surface, suitable for the intended finish in accordance with the relevant British Standards and the floor finish manufacturer's recommendations
- of a suitable sand cement mix (generally between 1:3 and 1:4½ cement:sand); where deeper than 40mm, concrete may be used
- installed within three hours of the concrete sub-floor being poured (where the floor is to include a monolithic slab)
- mixed using only proprietary additives that have been assessed in accordance with Technical Requirement R3
- thoroughly compacted, where required by the design, using either a heavy tamper, mechanical compactor or vibrator.

Proprietary non-structural screeds should be installed in accordance with the manufacturer's recommendations.

Surface sealers or hardeners should only be used in accordance with the manufacturer's instructions.

Where services are bedded in the screed:

- there should be a minimum 25mm of cover over the highest point of pipes and insulation
- provision should be made for the thermal movement of water pipes
- pipes should be protected against chemical attack (eg by using purpose-made sleeves or ducts).

Non-structural screed over underfloor heating should:

- be sub-divided into bays not exceeding 40m², with a maximum length of 8m, or installed per room
- have expansion joints which are consistent with those in the substructure
- have expansion joints between independently controlled heating zones.

Where proprietary non-structural screeds are used in conjunction with underfloor heating, the manufacturer's recommendations should be followed in relation to installation and the provision of expansion joints.

Where tiles are applied to proprietary screeds, movement joints should be provided in accordance with Clause 9.3.5.

Where concrete floor slabs are to serve directly as a wearing surface without an additional topping, they should be in accordance with BS 8204-2 and power floated.

Completed floor finishes should be protected against damage from traffic.

Standards relevant to screeding include:

BS 8204	Screeds, bases and in-situ floorings
BS 8201	Code of practice for installation of flooring of wood and wood-based panels
BS 8203	Installation of resilient floor coverings. Code of practice
BS EN 1264	Water based surface embedded heating and cooling systems

9.3.4.2 Non-structural screed thickness

Thickness of cement and sand screeds should be in accordance with with Table 2.

Table 2: Thickness of non-structural screed

Method of laying	Minimum thickness at any point (mm)
Installed monolithically with base	12
Installed on, and bonded to, a set and hardened base	25
Installed on a separating membrane (eg 1000g polyethylene)	50
Installed on resilient slabs or quilts (screed reinforced with wire mesh)	65
Above services, reinforcement or insulation to services	25

For concrete ground-bearing floors, a maximum 20mm monolithic screed may be acceptable as part of the required thickness.

9.3.4.3 Screed over insulation

Where screed is to be installed over insulation, the screed should be reinforced, and the insulation should:

- provide adequate compressive strength to support wet construction screeds and floor loads
- be tightly butted and, where required, turned up at perimeters to prevent thermal bridging
- be separated from the screed by a membrane (the membrane should be compatible with the insulation, and have joints lapped and taped, and be turned up at the perimeter).

Sound insulating floating floors should be in accordance with building regulations.

Where proprietary fibre-reinforced screeds are installed on resilient slabs or quilts, specification and installation should be in accordance with the manufacturer's recommendations, and the fibres should have satisfactory independent technical assessment for use in the control of shrinkage in screeds or concretes.

Figure 1: Screed over insulation

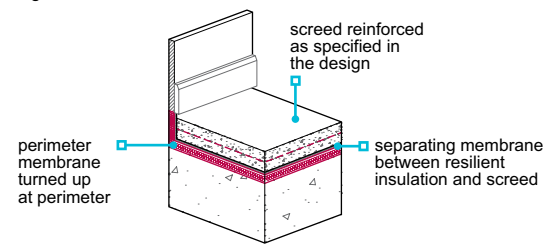

9.3.5 Ceramic, concrete, terrazzo and similar tile finishes

Tile flooring shall provide a suitable wearing surface for the location and intended use.

Before tiling is started:

- ensure that the substrate is sufficiently dry (generally, six weeks for concrete bases and three weeks for screed is adequate)
- ensure the substrate is reasonably true and flat ($\pm 3\text{mm}$ using a 2m straight edge)
- ensure that falls, where required, are in accordance with the design
- differences in level should be dubbed out
- the surface should be clean and free from laitance, dirt, dust, grease and materials incompatible with the adhesive.

Where a calcium sulphate (anhydrite) screed is used:

- ensure that the substrate is sufficiently dry (calcium sulphate screeds generally should be allowed to dry at a rate of one day per mm of screed thickness for screeds up to 40mm thickness, and two days per mm for any additional thickness over 40mm; however, it should be ensured that the moisture content does not exceed 75% RH before tiling begins)
- the weak layer of laitance which forms on the surface of the screed should be removed
- the screed should be sealed with an appropriate primer in accordance with the manufacturer's recommendations
- where it is likely to be exposed to occasional wetting (ie, where a bath or shower is present), it should be protected by the application of an additional intermediate waterproofing layer (tanking system) prior to the installation of tiling.

When installing tiles to floors:

- they should be bedded on a solid bed of mortar or proprietary adhesive, of a thickness appropriate for the material
- the manufacturer's recommendations should be followed where proprietary adhesives are used
- they should be arranged to minimise cutting and to provide joints which are straight, neat and of even width
- accessories, such as covings and skirtings, should match the tile pattern, and be fixed so that joints are aligned with those in the floor
- they should be installed with minimum 3mm joints, unless otherwise specified by the manufacturer.

Where tiles are to be fixed to a wood-based substrate:

- the floor should be designed to take the additional loads of tiles, and any other materials (eg overlays)
- they should be suitable for laying over a timber base
- they should be bedded with deformable (flexible) tile adhesive, eg C2S1, and grouted in accordance with the manufacturer's recommendations. Guidance on suitable backing surfaces for tiling on wood-based floors can be found in Table 3. For further guidance, see BS 5385 Parts 3 and 4.

Table 3: Suitable backing surfaces for tiling on wood-based floors

Conditions	Example location	Acceptable substructure	Intermediate waterproofing layer (tanking system) required	Additional requirements
Installations in normal internal conditions	Rooms which do not contain a shower or bath (eg kitchen/utility room, cloakrooms/WC)	Moisture-resistant wood-based floor decking: plywood ⁽¹⁾ to BS EN 636-3S or P5 chipboard ⁽²⁾ overlaid with 10mm plywood to BS EN 636-3	No	Tiles solidly bedded on flexible tile adhesive (eg C2S1) Water-resistant grout
Installations not immersed but subject to occasional wetting	Domestic bathrooms	Moisture-resistant wood-based floor decking (ie, BS EN 636-3S plywood ⁽¹⁾ or P5 chipboard ⁽²⁾), overlaid with minimum 10mm thick proprietary tile backing board (fibre-reinforced gypsum tile backer boards subject to assessment), or alternative wood-based board where approved for use as a tiling substrate by the manufacturer	No	Tiles solidly bedded on flexible tile adhesive (eg C2S1) Water-resistant grout
		proprietary tile backing board (fibre-reinforced gypsum tile backer boards subject to assessment) of an appropriate type and thickness used as the floor decking ⁽³⁾		
Installations not immersed but subject to frequent wetting	Wet rooms and communal showers	Moisture-resistant wood-based floor decking (as above), overlaid with minimum 10mm thick proprietary tile backing board (fibre-reinforced gypsum tile backer boards subject to assessment)	Yes (unless the manufacturer can demonstrate that the board is inherently watertight)	Tiles solidly bedded on flexible tile adhesive (eg C2S1) Water-resistant grout
		Proprietary tile backing board (fibre-reinforced gypsum tile backer boards subject to assessment) of an appropriate thickness suitable for use as the floor decking ⁽³⁾		
Installations in high-humidity areas	Areas with constant high-humidity (eg saunas and steam rooms)	Moisture-resistant wood-based floor decking (as above), overlaid with minimum 10mm thick proprietary tile backing board (fibre-reinforced gypsum tile backer boards subject to assessment)	No	Tiles solidly bedded on flexible tile adhesive (eg C2S1) Water-resistant grout
		Proprietary tile backing board (fibre-reinforced gypsum tile backer boards subject to assessment) of an appropriate type and thickness suitable for use as the floor decking ⁽³⁾		

Notes

- Plywood to BS EN 636-3S (minimum 15mm for joists at 400/450mm centres and minimum 18mm for joists at 600mm centres) screwed to the joists at 300mm centres with all square edges supported on joists or noggings (plywood should be installed with a 1.5-2mm movement gap between boards and at abutments, and be acclimatised to the room conditions and sealed on the underside and square edges, before laying, with a suitable sealer such as polyurethane varnish).
- Moisture-resistant P5 chipboard grade overlaid with minimum 10mm plywood to BS EN 636-3, acclimatised, sealed and fixed as previously indicated, or proprietary separating/decoupling layers, tile backing boards or tile bedding reinforcement sheets used in accordance with the manufacturer's recommendations.
- Proprietary tile backing boards should be assessed in accordance with NHBC Technical Requirement R3.

Movement joints should be:

- provided around the floor perimeter and at rigid upstands, where tiled areas are wider than 2m
- used to separate bays at 8-10m centers (where underfloor heating is proposed, the floor area should be divided up by intermediate movement joints into bays of a size no greater than 40m² with an edge length not greater than 8m
- a minimum of 3mm wide, unless otherwise specified by the manufacturer
- provided on suspended floors where tiles continue over changes in the sub-floor construction and flexing is likely to occur, eg over a supporting wall where end bearings of beam and block joists may be found.

Grout should be:

- cement-based epoxy resin or a proprietary product
- water-resistant, where tiles may become saturated.

Standards relevant to floor finishes include:

BS 8204-3	Screeds, bases and in-situ floorings — Polymer modified cementitious levelling screeds and wearing screeds. Code of practice
BS EN 13748-1	Terrazzo tiles — Terrazzo tiles for internal use
BS EN 14411	Ceramic tiles. Definition, classification, characteristics, assessment and verification of constancy of performance and marking
BS 5385-3	Wall and floor tiling — Design and installation of internal and external ceramic and mosaic floor tiling in normal conditions. Code of practice
BS 5385-4	Wall and floor tiling — Design and installation of ceramic and mosaic tiling in specific conditions. Code of practice
BS EN 13888	Grout for tiles. Requirements, evaluation of conformity, classification and designation

9.3.6 Wood finishes

Also see: BS 5250 and BRE Report 211 Thermal insulation: avoiding risks

Wood and wood-based flooring shall provide a suitable wearing surface for the location and intended use. Issues to be taken into account include:

- | | |
|--------------------------------|---|
| 1) thermal insulation and DPMs | 4) directly applied finishes (wood blocks, parquet, wood mosaic, etc) |
| 2) sound insulation | 5) indirectly applied finishes (soft wood boarding, wood-based panel products). |
| 3) condition of the substrate | |

Wood and wood-based flooring should be installed ensuring that:

- services beneath the floor finish are tested before the floor is installed
- underfloor heating is kept on before and during the floor laying
- wood finishes are conditioned to the appropriate moisture content
- where required, DPMs are incorporated in accordance with the manufacturer's recommendations and the design.

Standards relevant to wood floor finishes include:

BS 8201	Code of practice for installation of flooring of wood and wood-based panels
BS 1187	Specification for wood blocks for floors
BS 4050	Specification for mosaic parquet panels
BS 1202	Specification for nails
BS 1297	Specification for tongued and grooved softwood flooring

9.3.6.1 Thermal insulation and DPMs

Methods of providing insulation include:

- insulation positioned above in-situ concrete slab (DPM required)
- insulation positioned above dry, precast system (in certain circumstances, a DPM maybe omitted; see Chapter 5.2 Suspended ground floors for further information).

Figure 2: Location of DPM and insulation on ground-bearing slab

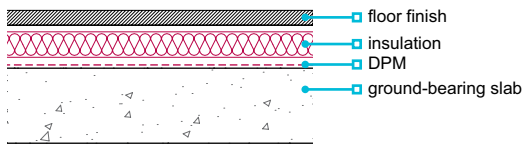
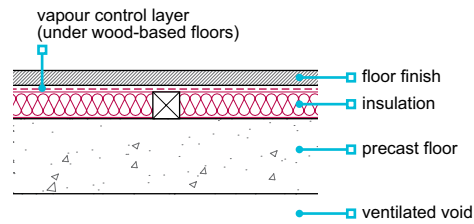

Figure 3: Location of DPM, VCL and insulation on precast floor



Proprietary insulated flooring should be in accordance with:

- Technical Requirement R3
- the manufacturer's recommendations on vapour control layers and DPMs.

9.3.6.2 Sound insulation

Floating floor finishes should be designed and constructed to:

- isolate the floor finish from the supporting floor and walls
- avoid excessive movement or squeaking
- avoid the use of fixings which penetrate the insulation layer
- ensure there are no air paths, especially at the perimeter.

Where flooring is to be installed on a resilient material on a separating floor, edges should be isolated from walls and skirtings by a resilient layer.

Where a floor relies on a soft floor covering to provide the minimum standard of sound insulation, the covering should be fixed permanently in position.

9.3.6.3 Condition of the substrate

Screeds or concrete to receive wood flooring should be dry. The floor should:

- be tested and the moisture content suitable, in accordance with BS 8201
- be allowed to cure for a sufficient period of time (generally two months for 50mm screed, and six months for concrete slabs), or
- have a DPM and/or air and vapour control layer incorporated in the floor construction to protect the wood finishes (moisture should not be trapped between the layers).

Screeds or concrete to receive wood flooring should:

- be free from high spots, nibs and major irregularities
- have differences in level dubbed out.

9.3.6.4 Directly applied finishes (wood blocks, parquet, wood mosaic, etc)

Directly applied finishes should be installed:

- in accordance with the manufacturer's recommendations
- using the correct adhesives, eg bitumen rubber emulsion in accordance with BS 8201 or proprietary adhesives assessed in accordance with Technical Requirement R3
- using evenly spread adhesives
- according to the specified pattern, and leaving gaps around the perimeter for movement.

Screeds or concrete surfaces should be treated with a suitable primer in accordance with the adhesive manufacturer's recommendations.

9.3.6.5 Indirectly applied finishes (softwood boarding, wood-based panel products)

Indirectly applied finishes should be installed with:

- air and vapour control layers where required
- preservative treated battens, in accordance with Chapter 3.3 Timber preservation (natural solid timber)
- provision made to support heavy items, such as storage heaters and boilers
- battens fixed to prevent excessive movement
- battens spaced in accordance with Table 4.

Table 4: Spacing of battens for indirectly applied floor finishes

	Thickness of finish (mm)	Maximum batten centres (mm)
P5 chipboard	18	450
	22	600
Plywood	15	450
	18/19	600
Oriented strand board (type OSB3)	15	450
	18/19	600
Other types of floor	In accordance with the manufacturer's instructions	

Chipboard and oriented strand board should be fixed to battens:

- with flat-head ring shank nails or screws
- with fixings 2.5 x the thickness of the board
- at 200mm-300mm centres at perimeters
- at 400mm centres on intermediate supports.

Plywood should be fixed to battens:

- with 10 gauge nails or screws
- a minimum of 10mm from the edges of boards
- at 150mm centres at perimeters
- at 300mm centres on intermediate supports.

9.3.7 Flexible sheet and flexible tile finishes

Also see: BS 5250 and BRE Report BR 262

Flexible sheet and flexible tile finishes shall provide a suitable wearing surface for the location and intended use.

Flexible sheet and flexible tile finishes should be:

- installed in accordance with the manufacturer's recommendations, and generally be fully bonded
- installed on a backing surface which is even and without high spots or cracks; where necessary, using a fabricated underlay of a type and thickness recommended by the flooring manufacturer or in accordance with Table 5
- reasonably level and smooth, particularly at doorways and junctions
- fitted with skirtings, coves, coverstrips and other preformed components, where required, and in accordance with the manufacturer's recommendations.

Table 5: Acceptable types of fabricated underlay for boarded surfaces

Type of underlay	Minimum thickness (mm)
Hardboard	4.8
Plywood	5.5

Plywood or hardboard fabricated underlays should be fixed:

- with ring shank nails or screws finished flush with surface
- with fixings 2.5 x the thickness of the underlay (but no longer than the combined thickness of the underlay and deck)
- with nails/screws at least 10mm from the edge of the panel
- around perimeters, at 100mm centres
- across the sheets, at 150mm centres.

Flexible sheet flooring materials should:

- be stored in a clean and ventilated place
- not be stored in cold conditions, unless permitted by the manufacturer
- not be exposed to temperatures less than 18°C for a period of 24 hours before, or during, laying.

The substrate should be sufficiently dry to prevent adverse effects on the flooring, and where:

- there is a risk of trapping moisture or interstitial condensation, permeable finishes should be used
- flexible sheet or tile flooring is installed on ground-bearing concrete floors, a DPM should be incorporated to prevent rising moisture adversely affecting floor finishes.

When installing flexible sheet or tile flooring:

- ensure underfloor services are not damaged
- it should be cut so that it fits neatly around fittings, pipes, etc
- adhesives should be spread evenly and left for the correct period of time to ensure full bonding
- the surface should be pressed down firmly, loaded or rolled as necessary to prevent curling, lifting or bubbling
- surplus adhesive should be removed
- welded joints should be provided in accordance with the manufacturer's recommendations
- adjustment after initial contraction or expansion should be made where necessary.

Standards relevant to flexible sheet and tile finishes include:

BS EN ISO 10581	Resilient floor coverings. Homogeneous poly(vinyl chloride) floor covering. Specifications
BS EN ISO 10595	Resilient floor coverings. Semi-flexible/vinylcomposition (VCT) poly(vinyl chloride) floor tiles. Specification
BS EN 650	Resilient floor coverings. Polyvinyl chloride floor coverings on jute backing or on polyester felt backing or on a polyester felt with a polyvinyl chloride backing. Specification
BS EN 651	Resilient floor coverings. Polyvinyl chloride floor coverings with foam layer. Specification
BS EN 12104	Resilient floor coverings. Cork floor tiles. Specification
BS 8203	Installation of resilient floor coverings — Code of practice

9.3.8 Asphalt finishes

Asphalt finishes shall be suitable for the location and intended use.

Mastic asphalt floor finishes should be:

- designed and constructed in accordance with BS 8204-5
- either Grade I or II and 15mm-20mm thick (which applies to the floor finishes and underlay)
- applied as one coat when used as underlay for other finishes
- in accordance with the floor manufacturer's recommendations when used with a suspended floor system.

9.3.9 Staircase finishes

Also see: Chapter 6.6

Staircase finishes shall permit safe usage and be suitable for their intended use.

The rise and going should remain uniform after application of the staircase finish, including at the top and bottom of the flight (see Clause 6.6.8).

For communal stairs (eg in escape routes in blocks of flats), non-slip nosings or inserts should be:

- provided where specified
- fixed in accordance with the manufacturer's recommendations.

9.3.10 Further information

- *BS 5250:2021 Management of moisture in buildings. Code of practice*
- *BRE Report BR 262 Thermal insulation: avoiding risks. 3rd Edition*



Chapter 9.4



Finishings and fitments

This chapter gives guidance on meeting the Technical Requirements for finishings and fitments (including cupboards and internal trim).

9.4.1	Compliance	02
9.4.2	Provision of information	02
9.4.3	General provisions – cupboards and fitments	02
9.4.4	Finishings and internal trim	02
9.4.5	Joinery	03
9.4.6	Airing cupboards, cupboards, worktops and fitments	03
9.4.7	Ironmongery, prefabricated items and other materials	03
9.4.8	Protection and handover	04

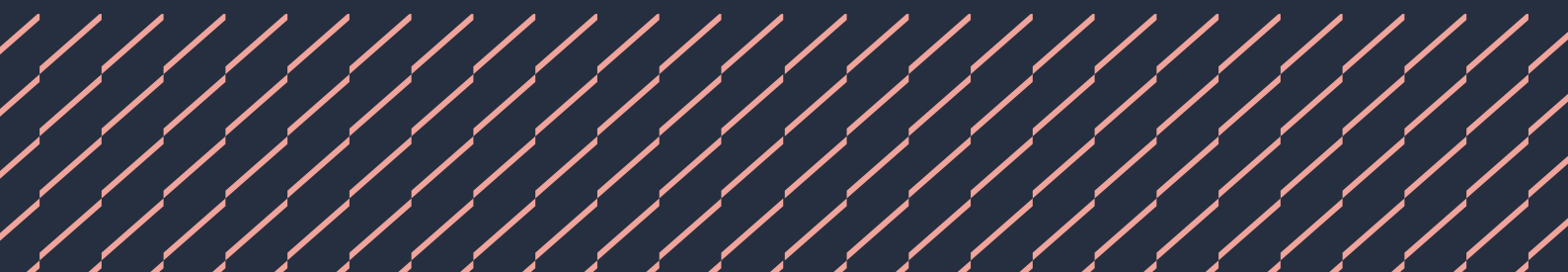

Figure reference table

Figure Reference Table 9.4

Fig No	Title/Description	Clause	Page
Figure 1	Airing cupboard requirements	9.4.6	3

9.4.1 Compliance

Also see: Chapter 2.1

Finishings and fitments shall comply with the Technical Requirements.

Finishings and fitments which comply with the guidance in this chapter will generally be acceptable.

9.4.2 Provision of information

Designs and specifications shall be produced in a clearly understandable format, include all relevant information and be distributed to the appropriate personnel.

Designs and specifications should be issued to site supervisors, relevant specialist subcontractors and suppliers.

9.4.3 General provisions – cupboards and fitments

The builder shall provide fixed and built-in fitments in accordance with the specification.

In kitchens, the specification should allow for:

- preparation and cooking of food
- washing up, drying and storage of dishes and utensils
- storage of dry foods
- storage of perishable foods
- laundering
- storage of domestic cleaning appliances (part of which should be suitable for brooms, upright cleaners and similar equipment)
- 1m circulation space in front of all work surfaces, cupboards and appliances.

A depth of 600mm can be assumed for appliances (where intended but not provided).

Space or facilities for laundering and cleaning items may be provided outside the kitchen area.

Space should be provided for general storage, clothes, linen and bedding. Airing cupboards are required in homes which do not have central or whole home heating.

Kitchen units should be installed in accordance with the manufacturer's instructions, ensuring that they are adequately fixed to a suitable substrate.

Shelving supports should be fixed securely and so that shelves are level.

9.4.4 Finishings and internal trim

Also see: Chapter 6.8

Finishings and internal trim shall be suitable for their location and intended use, securely fixed, and finished to established standards of workmanship.

When fixing trim and components:

- they should be in accordance with the specification
- fireplace surrounds, panelling and features should be complete and suitably joined to the adjacent surfaces
- nails should be punched below the surface of timber, and holes filled
- damage should be avoided (where damage does occur, it should be made good).

Trim and finishings should be:

- sufficiently wide to mask joints around built in fitments, etc allowing for movement and shrinkage
- fixed in accordance with Building Regulations (eg with minimum separation distances where near heat sources)
- selected and installed to give a neat appearance
- installed in accordance with the manufacturer's recommendations.

Architraves should be:

- parallel to frames and linings
- accurately mitred, or scribed, to fit tightly and neatly
- fixed with an equal margin to each frame member
- securely fixed to prevent curling.

Skirting should:

- be mitred and scribed at external and internal angles, as appropriate
- tightly abut architraves
- run level and scribed to floors.

Proprietary trim, skirting and architraves should be fixed in accordance with the manufacturer's recommendations.

9.4.5 Joinery

Wood and wood-based materials shall be of the quality and dimensions required by the design.

Joinery and the materials used should be installed to established standards of workmanship, and have no visible defects after the finish has been applied. Issues that should be taken into account include:

- fit and construction of joints (including finger joints)
- gluing and laminating
- construction of moving parts
- surface finishes.

Relevant standards include:

BS EN 942	Timber in joinery. General requirements
BS EN 312	Particleboards. Specifications
BS 1186	Timber for and workmanship in joinery

9.4.6 Airing cupboards, cupboards, worktops and fitments

Airing cupboards, cupboards, worktops and fitments shall be installed to provide satisfactory appearance and performance. The builder shall provide fixed and built-in fitments in accordance with the design.

Cupboards, worktops and fitments should be:

- checked to ensure they are undamaged before they are installed
- installed as shown in the design (worktops spanning between units may require additional support)
- plumb, level and scribed to wall faces, where necessary.

Cupboards should be installed ensuring that:

- doors operate freely and fit openings closely and evenly
- drawers run smoothly, and locks and catches properly engage.

Cupboards (including wall-hung units) should be securely fixed, using:

- fixings of an appropriate size, and in accordance with the manufacturer's instructions (generally, plugs and screws to masonry and screws to timber)
- the predrilled holes in units and brackets provided by the manufacturer.

Where worktops or unit panels are cut, edges should be sealed using a metal or plastic strip glued to the edge with waterproof adhesive. Alternatively, an appropriate waterproof joint may be used. Sinks and hob units which are inset in worktops, and vanity units, should be sealed with a waterproof joint.

Where appropriate, gaps between fitments and wall tiling should be sealed with a waterproof joint and brought to a smooth finish.

Wardrobes should be fitted with hanging rails, and intermediate supports used where necessary to avoid bending.

Internal doors (including airing cupboard doors) should be fitted in accordance with Chapter 6.7 Doors, windows and glazing.

Airing cupboards should:

- be separated from other storage
- have a minimum 0.5m² of easily reached shelving suitable for the airing of clothes
- have a 300mm minimum spacing between shelves
- have a suitable heat source, such as a hot water cylinder
- not have shelving higher than 1.5m.

Figure 1: Airing cupboard requirements

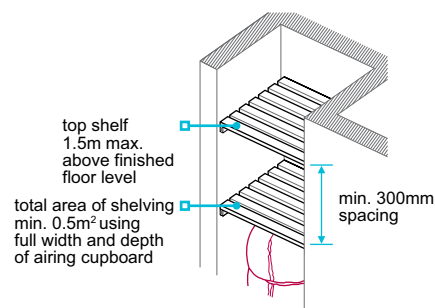

9.4.7 Ironmongery, prefabricated items and other materials

Ironmongery, prefabricated items and other similar materials shall be suitable for the intended use.

Relevant standards include BS EN 1935 Building hardware. Single-axis hinges. Requirements and test methods.

9.4.8 Protection and handover

Finishings and fitments shall be suitably protected during construction, and be undamaged at handover.

Appropriate protection should be provided to finishings and fitments (including to doors, trim, balustrades, fireplace surrounds, panelling and other special features) to ensure they are not damaged. Kitchens, including cupboards, doors, fittings and worktops, should be suitably protected.

Prior to completion and handover:

- work should be left in a clean state
- decorating should be completed in accordance with Chapter 9.5 Painting and decorating
- temporary coverings and protection should be removed, and the fitments and finishings cleaned and dusted.



Chapter 9.5



Painting and decorating

This chapter provides guidance on meeting the Technical Requirements for painting and decorating.

9.5.1	Compliance	01
9.5.2	Provision of information	01
9.5.3	Storage	01
9.5.4	Conditions for painting and decorating	01
9.5.5	Timber	01
9.5.6	Steel	02
9.5.7	Walls	02
9.5.8	Wallpapering	03
9.5.9	Other surfaces	03
9.5.10	Completed painting and decorating	03

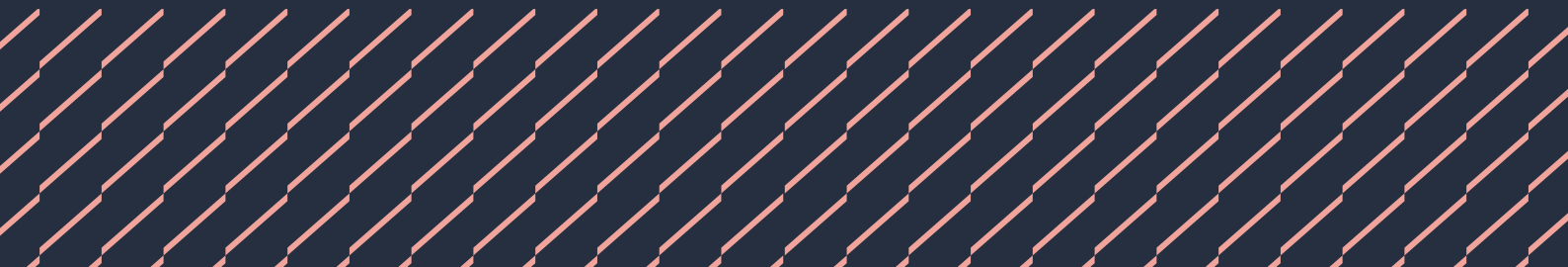

9.5.1 Compliance

Also see: Chapter 2.1

Painting and decorating shall comply with the Technical Requirements.

Painting and decorating that complies with the guidance in this chapter will generally be acceptable.

Paint finishes should be selected and applied in accordance with BS 6150 Painting of buildings. Code of practice.

Chapter 9.1 A consistent approach to finishes provides further guidance on the quality of painting and decorating finishes.

9.5.2 Provision of information

Designs and specifications shall be produced in a clearly understandable format, include all relevant information and be distributed to the appropriate personnel.

Designs and specifications should be issued to site supervisors, relevant specialist subcontractors and suppliers, and include the following information:

- specification of preparatory work
- details of specialist finishes.
- schedule of finishes

9.5.3 Storage

Materials for painting and decorating shall be adequately protected from the weather.

Painting and decorating materials should:

- be protected against frost before use
- not be used where they have been damaged by frost.
- be stored in dry conditions

9.5.4 Conditions for painting and decorating

Painting and decorating shall take account of the climatic and building conditions to ensure a suitable finish.

The painting and decoration of external surfaces should not be undertaken where:

- weather conditions may adversely affect the completed work
- surfaces are moist
- frost occurs, or is due to occur, before the paint has been applied or has dried
- rain is expected before the paint dries.

When decorating internal walls:

- cold surfaces may cause problems with water-borne paints, even though the air temperature may be above freezing
- surfaces should be free from condensation before applying paint and coatings; they should not be applied until the moisture has evaporated from the surface.
- paintwork should not be adversely affected by dust

9.5.5 Timber

Also see: Chapter 3.3

The painting and decorating of timber and timber-based materials shall be compatible with the species of timber, provide adequate protection and be suitable for the intended use and location. Prefabricated components and joinery shall be finished to a suitable quality, and protected.

When painting or decorating timber, the moisture content should be a maximum of 18%.

Paint and paint systems should be used in accordance with the manufacturer's recommendations and be compatible with the surface to be decorated.

Decorative finishes applied to timber treated with a fire-retardant must be compatible with the treatment used. Guidance on painting fire-retardant treated timber should be sought from the treatment manufacturer.

Preparation should ensure:

- door and window furniture is removed
- sharp arrises are rubbed down (to enable an even coating)
- unsound wood, loose or highly resinous knots, etc are cut out, replaced and made good
- surfaces are free from dirt, dust and moisture
- raised grains, tool and machine marks are removed
- where there is deterioration of the primer or seal coat, surfaces are rubbed down and a second coat applied
- surfaces are refinished with fillers and glasspaper as appropriate
- where joinery is delivered preprimed, priming meets the requirements in this chapter
- nail holes, splits and other imperfections are stopped
- where joinery is prefabricated, the first coat of paint or stain is applied before fixing.

Knotting should:

- comply with BS 1336 Specification for knotting (this may not be effective against heavy exudation of resin)
- be applied using a brush, or as part of the priming process for joinery.

One full round coat of primer should be applied to all surfaces to be painted, including:

- hidden surfaces of external woodwork
- rebates for glazing and backs of glazing beads.
- cut ends of external woodwork

Primers should be in accordance with BS 7956 Specification for primers for woodwork.

Where specified, paint or stain should be applied to external timber to provide protection from moisture. Primer, paint and stain finishes should be compatible with any preservative treatment which may have been used.

Undercoat and gloss should be applied ensuring that it provides a satisfactory finish, and:

- it is not thinned (unless recommended by the manufacturer)
- a minimum of one priming coat, one undercoat and one finishing coat are used (unless an alternative recommendation is made by the manufacturer)
- each application is a full round coat and surfaces are lightly rubbed down with glasspaper between coats
- each coat is applied within one month of the previous.

Stain and varnishes should be:

- applied as recommended by the manufacturer to provide appropriate cover
- applied when the substrate is dry
- applied to surfaces which have been suitably prepared to provide adequate adhesion and an acceptable appearance
- suitable for the species of timber.

Varnish should be applied with a minimum of three coats on interior surfaces. On exterior surfaces, clear varnishes will have a short service life and require regular maintenance to avoid premature failure; as a result, the use of clear varnishes should be avoided.

Stain should:

- be a two-coat system or be in accordance with the manufacturer's recommendations
- not be applied to door or window rebates which are to be glazed with linseed-oil putty.

BS EN 927-1 provides guidance on exterior wood coating systems.

Prefabricated joinery and components should be:

- protected from damage
- stored under cover and primed, where supplied untreated, as soon as possible after delivery
- supplied with, or given, a coat of primer to all surfaces before fixing
- reprimed where primer is damaged.

9.5.6 Steel

Also see: Chapter 6.5

Decorative finishes to steelwork shall provide adequate protection and be suitable for the intended use and location.

Decorative finishes may be applied to galvanised steel following suitable preparation with a mordant wash.

Decorative finishes applied to steelwork that has been protected by coatings (including intumescent paint for fire resistance) in accordance with Chapter 6.5 Steelwork, must be compatible with the protective coating. The manufacturer's recommendations should be followed. Any damage to the protective coatings should be made good prior to decorative finishes being applied.

9.5.7 Walls

Walls shall be finished to provide an even and consistent appearance, to established levels of workmanship. Issues to be taken into account include:

- 1) external masonry and rendering
- 2) plaster and plasterboard surfaces.

9.5.7.1 External masonry and rendering

Paint or decorative finishes to external masonry and rendering should:

- be appropriate for the substrate and in accordance with the manufacturer's recommendations
- not be applied to external brickwork or render where they could trap moisture in the construction and cause frost damage, sulfate attack or other detrimental effects.
- be applied to surfaces which are clean and free from dust and loose deposits

Where bricks have no upper limit on their soluble salt content, the brick manufacturer's written agreement to the application of a finish should be obtained.

Where the decorative system is part of the weather resistance of the rendering, it should be assessed in accordance with Technical Requirement R3.

Where surfaces have varying suction, they should be stabilised with a treatment recommended by the manufacturer.

9.5.7.2 Plaster and plasterboard surfaces

A sealing coat should be applied to dry lining, and surfaces prepared for decoration, in accordance with the manufacturer's recommendations.

Plaster and plasterboard surfaces should be prepared in accordance with the manufacturer's recommendations and the design. Where plaster and skim coat is applied to plasterboard:

- surfaces should be visibly sound, without signs of powdering or crumbling
- joints should be completed and cracks, nail holes and surface imperfections filled
- the surface should be rubbed down with glasspaper and dusted, where necessary
- dirt and loose surface deposits, especially dust from sanding of filled joints, should be removed
- surfaces should be stabilised, either with a coat of thinned paint or with a sealant as recommended by the manufacturer
- a minimum of two coats of paint should be applied
- plaster should have adequate time to dry before decorating begins.

Where building boards are used, coatings should be in accordance with the board manufacturer's recommendations.

9.5.8 Wallpapering

Wallpapering shall be finished to provide an even and consistent appearance, to established levels of workmanship.

Where wallpaper or coverings are used:

- surfaces should be dry, even and smooth before wallpaper is applied
- surfaces should be sized or sealed as necessary
- adhesives should be in accordance with the wallpaper manufacturer's recommendations
- they should be properly aligned and neatly fixed
- electrical switch plates should be temporarily removed and the papering accurately trimmed so that it will tuck behind the fitting upon completion.

9.5.9 Other surfaces

Surfaces shall be finished to provide an even and consistent appearance, to established levels of workmanship.

For glazing rebates in windows and doors treated with stains:

- linseed-oil putty should not be specified
- appropriate sealants should be used in accordance with the manufacturer's recommendations.

The insides of metal gutters (other than aluminium) should be painted with a suitable protective paint.

Non-ferrous pipework (eg copper pipes) should be painted with the normal decorative finishes.

9.5.10 Completed painting and decorating

Completed paintwork shall be to established levels of workmanship and suitably protected.

Painting and decorating should be complete, and:

- surfaces that are not intended to be painted should be free of paintmarks
- evenly applied, free from conspicuous runs or prominent brush marks, and the background or undercoat should not be visible
- where ironmongery has been removed, it should be correctly replaced
- removed and reapplied where spilt, splashed or badly applied
- protected against dirt and damage until handover.



Part 10

External works





Chapter 10.1



Garages

This chapter gives guidance on meeting the Technical Requirements for integral, attached and detached garages.

10.1.1	Compliance	02
10.1.2	Provision of information	02
10.1.3	Garage foundations	02
10.1.4	Garage floors	03
10.1.5	Garage walls	04
10.1.6	Resistance to fire spread	05
10.1.7	Security	06
10.1.8	Doors and windows	06
10.1.9	Garage roofs	06
10.1.10	Permanent prefabricated garages and carports	08
10.1.11	Services	08

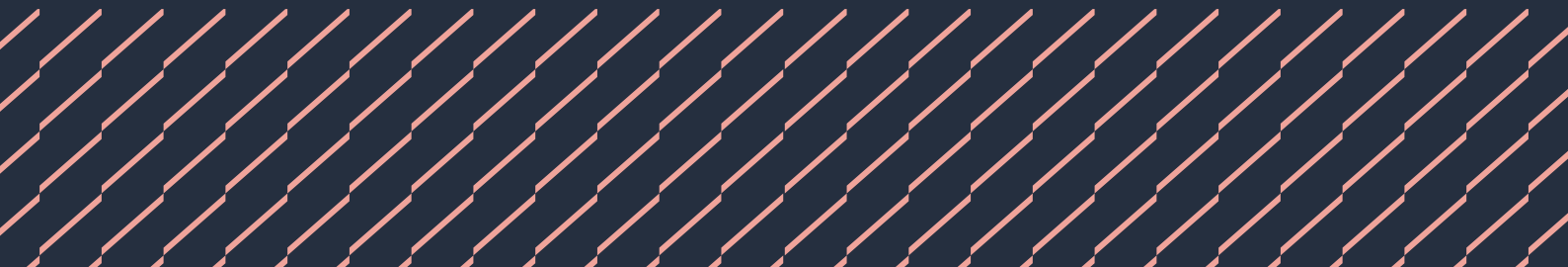

Figure reference table

Figure Reference Table 10.1

Fig No	Title/Description	Clause	Page
Figure 1	Specifications for unreinforced concrete slabs	10.1.3.3	2
Figure 2	Construction joints in unreinforced concrete floor slabs	10.1.4.7	4
Figure 3	Fire-resisting masonry wall between garage and dwelling	10.1.6	6
Figure 4	Fire-resisting timber wall between garage and dwelling	10.1.6	6
Figure 5	Fire-resisting ceiling or floor between garage and dwelling	10.1.6	6
Figure 6	Calculating gable height	10.1.9.3	7

10.1.1 Compliance

Also see: Chapter 2.1

Garages shall comply with the Technical Requirements.

Garages which comply with the guidance in this chapter will generally be acceptable.

10.1.2 Provision of information

Designs and specifications shall be produced in a clearly understandable format, include all relevant information and be distributed to the appropriate personnel.

Designs and specifications should be issued to site supervisors, relevant specialist subcontractors and suppliers, and include the following information:

- location of garages
- relevant levels, in relation to an agreed reference point
- details of foundations
- waterproofing arrangements
- construction details of the roof structure and coverings
- construction details for walls
- external and internal finishes
- services, where applicable
- type of garage or structure.

10.1.3 Garage foundations

Also see: Chapter 4.3

Garage foundations shall transmit all loads to the ground safely and without undue movement. Issues to be taken into account include:

- | | |
|---|----------------------------|
| 1) hazardous ground | 4) adjacent structures |
| 2) type of foundation required for integral/attached garages | 5) underground services |
| 3) type of foundation required for detached garages and blocks of garages | 6) provision for movement. |

Garage foundations should adequately support the imposed loads, taking account of ground conditions.

Further guidance is given in Chapter 4.3 Strip and trench fill foundations.

10.1.3.1 Hazardous ground

For foundations on hazardous ground, the following chapters are relevant:

- 4.1 Land quality — managing ground conditions
- 4.2 Building near trees
- 4.4 Raft, pile, pier and beam foundations
- 4.5 Vibratory ground improvement techniques.

Any existing fill on the site of the garage should be examined and identified. Where any potential health hazard or risk of damage is indicated, appropriate precautions should be taken, as described in the following chapters:

- 4.1 Land quality — managing ground conditions
- 5.1 Substructure and ground-bearing floors.

10.1.3.2 Type of foundation required for integral/attached garages

Foundations for integral or attached garages should be the same as those for the home, unless proper consideration is given to each foundation and the possibility of differential movement between them.

10.1.3.3 Type of foundation required for detached garages and blocks of garages

Foundations for detached individual garages or blocks of garages should avoid damage caused by differential loads and uneven settlement.

Where the ground is uniform and provides a satisfactory foundation bearing, an unreinforced edge thickened concrete slab may be used.

Unreinforced concrete slabs should:

- have a minimum thickness of 100mm
- have a minimum downstand thickening of 350mm below ground level around the whole perimeter of the slab
- have a minimum width of edge thickening of 300mm
- be constructed on 100mm minimum of properly compacted hardcore
- have dimensions not exceeding 6m in any direction; for dimensions greater than this, movement joints should be provided.

Figure 1: Specifications for unreinforced concrete slabs

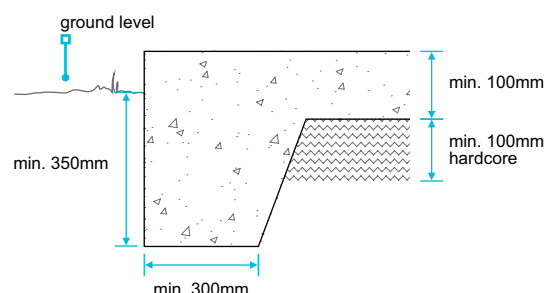

10.1.3.4 Adjacent structures

Foundations for garages should not impair the stability of the home or any other adjacent structure.

10.1.3.5 Underground services

Garage foundations that are to be above or near services should be constructed so that no excessive settlement of foundations or damage to services occurs (see Chapter 5.3 Drainage below ground).

10.1.3.6 Provision for movement

Movement joints in foundations should be provided:

- between homes and attached garages where there is a change of foundation type
- at 6m intervals where unreinforced concrete slab foundations are used.

10.1.4 Garage floors

Also see: Chapters 5.1 and 5.2

Garage floors shall transmit all loads to either the foundations or the ground safely and without undue movement. Issues to be taken into account include:

- 1) bearing capacity of the ground
- 2) resistance of the floor to moisture from the ground
- 3) resistance of the floor to hazardous gas
- 4) thickness of floor slabs
- 5) floor drainage
- 6) structural topping
- 7) construction joints.

Garage floors will be acceptable where they are in accordance with any of the following:

- Chapter 5.1 Substructure and ground-bearing floors
- Chapter 5.2 Suspended ground floors
- the guidance given in this chapter.

Unless ventilation is specifically required, the void beneath a garage floor which is suspended precast concrete may be unventilated where:

- the floor has adequate durability
- the ground beneath is well drained
- there is unlikely to be a build-up of soil gases.

10.1.4.1 Bearing capacity of the ground

Where the depth of fill exceeds 600mm, concrete floors should be in accordance with Chapter 5.2 Suspended ground floors and BS 8103-1.

Supporting fill should comply with the requirements in Chapter 5.1 Substructure and ground-bearing floors.

Where protection is needed to prevent attack by sulfates in either the ground, groundwater or fill below the slab, an impervious isolating membrane should be provided between the concrete and the ground.

10.1.4.2 Resistance of the floor to moisture from the ground

Generally, a DPM is unnecessary, except where:

- it is needed to prevent dampness entering the home, or
- the floor has to be protected against chemical attack from the ground.

Where no DPM is provided, the floor may show signs of dampness.

Where the floor is below ground level, precautions should be taken to prevent the entry of groundwater, and tanking may be required.

10.1.4.3 Resistance of the floor to hazardous gas

Where hazardous gas precautions are required and a property includes either an integral or attached garage, notwithstanding the inclusion or omission of a connecting doorway or absence or presence of habitable accommodation above the garage, the hazardous gas precautions should be continuous to the garage(s) and extend to the perimeter of the property.

Membranes should not be exposed and be protected against physical damage.

Following a site-specific risk assessment and specialist advice, detached garages may also require hazardous gas precautions.

10.1.4.4 Thickness of floor slabs

Ground-bearing floors, where provided, should not be less than 100mm thick, including a float finish.

10.1.4.5 Floor drainage

Where practicable, garage floors should be laid to falls to ensure that water or spillage is directed out of the garage via the vehicle doorway.

10.1.4.6 Structural topping

Where reinforced screeds are to be incorporated as structural topping, they should be designed by an engineer in accordance with Technical Requirement R5.

10.1.4.7 Construction joints

If the floor area of a garage exceeds 16m²:

- either the floor slab should be reinforced, or
- construction joints should be provided which equally divide the floor area into bays less than 16m².

Figure 2: Construction joints in unreinforced concrete floor slabs

Double garage (double width)

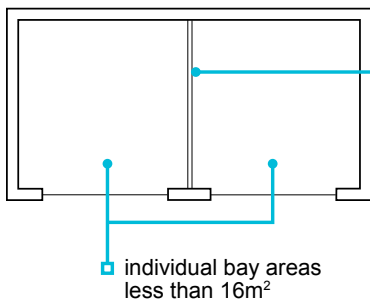

construction joint along length of garage at mid width

construction joint across width of garage at mid length

individual bay areas less than 16m²

Double garage (double length)

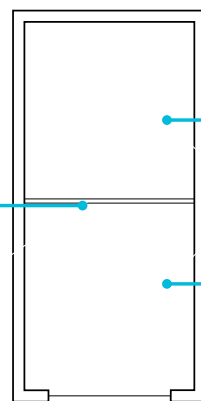

individual bay areas less than 16m²

Examples of unreinforced concrete floors in garages where the total floor area exceeds 16m²

10.1.5 Garage walls

Walls for garages shall transmit all loads to foundations safely and without undue movement. Issues to be taken into account include:

- | | |
|--|---|
| 1) stability of walls above ground | 3) provision for movement |
| 2) stability of walls retaining ground | 4) adequate resistance to rain and groundwater. |

Garage walls will be acceptable where they are in accordance with any, or a combination, of the following:

- Chapter 5.1 Substructure and ground-bearing floors
- Chapter 6.1 External masonry walls
- the guidance given in this clause.

If integral garages are formed within a timber frame building, the construction of the garage walls should be in accordance with Chapter 6.2 External timber framed walls.

10.1.5.1 Stability of walls above ground

Walls for detached garages and external walls for attached garages should:

- be no less than 90mm thick
- have adequate lateral restraint against wind loading.

Piers should be located in single leaf walls:

- up to 200mm thick
- which are greater than 2.5m in length or height and which do not contain a major opening ie, garage door
- at corners, unless buttressed by a return of at least 390mm
- at intermediate centres not exceeding 3m
- either side of a major opening ie, garage door.

Piers should also:

- be built off the foundation
- extend the full height of the wall
- measure at least 390mm x 190mm or 327mm x 215mm depending upon masonry unit size
- be bonded or tied to walls with flat stainless steel wall ties, 20mm x 3mm in cross section, placed in pairs and not more than 300mm centres vertically.

10.1.5.2 Stability of walls retaining ground

Garage walls retaining ground should be:

- suitable for the ground conditions
- structurally adequate.

Where garage walls act as retaining walls, they should be designed in accordance with Chapter 5.1 Substructure and ground-bearing floors or by an engineer in accordance with Technical Requirement R5.

10.1.5.3 Provision for movement

Movement joints in garage walls, as described in BS EN 1996-2, should be provided:

- between homes and attached garages
- where there are movement joints in foundations.

10.1.5.4 Adequate resistance to rain and groundwater

To protect the wall from rising ground moisture, a DPC should be provided at a level at least 150mm above the level of adjacent ground.

Garage walls constructed from a single leaf of masonry, such as brickwork or blockwork approximately 100mm thick, will not be impervious to wind-driven rain and consequently could become damp.

In areas of severe exposure or worse, single leaf walls may require a high standard of workmanship and possibly surface treatment to prevent an unacceptable level of rain penetration.

Where a cavity wall is to be used as an alternative to surface treatment of a single leaf wall, it would be acceptable to use a cavity of less than 50mm in this instance.

Where a garage is integral or attached, the design should ensure that dampness cannot enter the home.

Where a wall is below ground level, precautions should be taken to prevent the entry of groundwater by:

- tanking (see Chapter 5.4 Waterproofing of basements and other below ground structures)
- the use of DPCs and DPMs
- drainage of ground behind the wall.

10.1.6 Resistance to fire spread

Garages shall be constructed so as to prevent fire spread to the home from the garage.

Fire resistance between homes and integral or attached garages may be provided by:

- a fire-resisting wall in brickwork, blockwork or studwork up to the underside of the roof covering (minimum REI 30) with junctions fire-stopped
- a fire-resisting floor or ceiling (minimum REI 30)
- constructions where 30 minutes fire resistance can be proven.

Doors between homes and attached/integral garages should be fire doors and be fitted with a self-closing device. Consult relevant Building Regulations for performance requirements.

Figure 3: Fire-resisting masonry wall between garage and dwelling

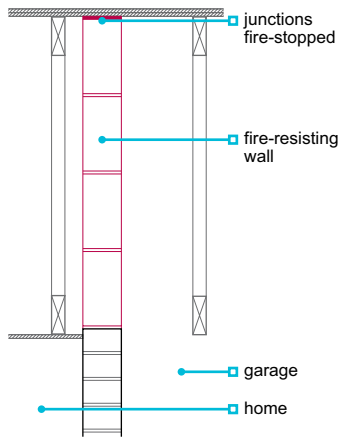

Figure 4: Fire-resisting timber wall between garage and dwelling

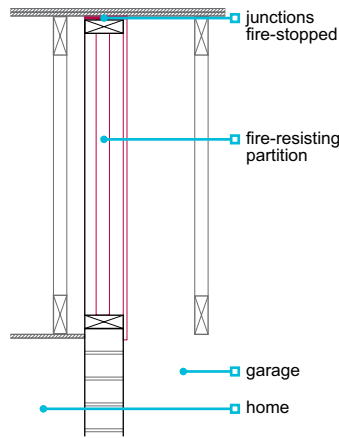
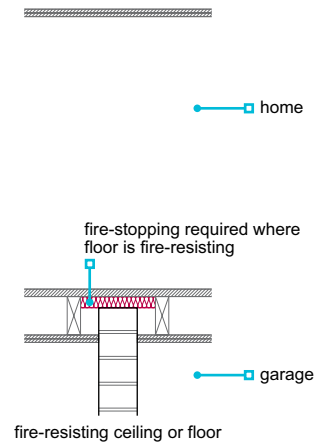

Figure 5: Fire-resisting ceiling or floor between garage and dwelling



10.1.7 Security

Garages shall be constructed to provide reasonable security against unauthorised entry, in particular where garages are linked.

Where garages of different ownership are linked, walls should prevent direct access from one garage to another.

The following should provide adequate security:

- walls — masonry construction, or timber frame with two layers of plasterboard on each side
- walls where fire resistance is not required — timber frame with one layer of 6mm plywood or 9mm OSB on each side.
- ceilings — two layers of plasterboard

10.1.8 Doors and windows

Garage doors and windows shall be adequate for their purpose. Issues to be taken into account include:

- 1) robustness
- 2) ease of operation.

Doors and windows will be acceptable where they are in accordance with Chapter 6.7 Doors, windows and glazing.

10.1.8.1 Robustness

Frames should be selected and fixed having taken into account the type and weight of the garage door.

10.1.8.2 Ease of operation

Proprietary doors and door gear should be installed in accordance with the manufacturer's recommendations.

Care should be taken to ensure that garage doors are in proper working order at handover.

10.1.9 Garage roofs

Also see: Chapter 7.2

Garage roofs shall satisfactorily resist the passage of rain and snow to the inside of the building, support applied loads and self-weight, and transmit the loads to the walls safely and without undue movement. Issues to be taken into account include:

- 1) holding down
- 2) bracing
- 3) restraint
- 4) detailing at abutments
- 5) movement
- 6) adequate disposal of rainwater.

Garage roofs will be acceptable where they are in accordance with:

- Chapter 7.1 Flat roofs, terraces and balconies, or
- Chapter 7.2 Pitched roofs.

10.1.9.1 Holding down

To prevent uplift, flat roofs and, where necessary, pitched roofs should be provided with holding-down straps at not more than 2m centres where the roof members bear on the supporting wall.

Holding-down straps should be:

- provided where the roof pitch is below 15° or the roof has a lightweight covering with a laid mass of less than 50kg/m²
- where local experience suggests there is a risk from wind gusts
- provided in accordance with the design
- a minimum cross-section of 30mm x 2.5mm (galvanised steel straps are generally acceptable) or proprietary straps and fixings
- at least 1m long and have three fixings to the wall, or turned into a bed joint.

10.1.9.2 Bracing

The building designer should specify all bracing. Trussed rafter roofs should be braced in accordance with Chapter 7.2 Pitched roofs, unless the roof is designed and braced in accordance with PD 6693-1.

All timber bracing to trussed rafters should be at least 100mm x 25mm in section and nailed twice to each trussed rafter. Nailing should be 3.35mm (10 gauge) x 65mm long galvanised round wire nails.

10.1.9.3 Restraint

For garages of masonry construction, the gable should be restrained at rafter level with restraint straps. Restraint should also be provided at ceiling level where the height (h) exceeds:

- 16 x thickness of the wall for single leaf walls
- 16 x sum of thickness of leaves + 10mm for cavity walls.

Note: 'h' should be measured from the top of foundations or from the underside of the floor slab where this provides effective lateral restraint.

Figure 6: Calculating gable height

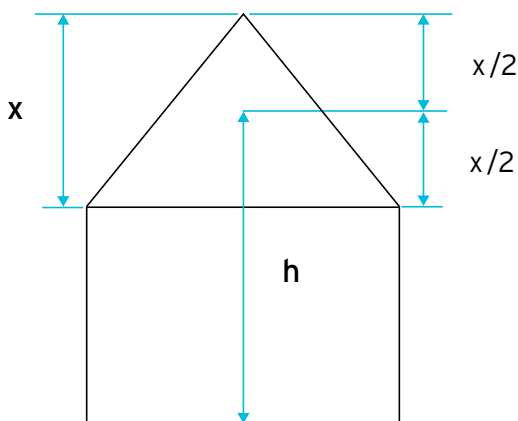

The restraint at rafter level may be provided by restraint straps or by a gable ladder.

Where straps are used, they should have a minimum cross-section of 30mm x 5mm or be proprietary straps that have been designed for lateral restraint purposes. Straps should be fixed to rafters with solid blocking (or be fixed to the longitudinal bracing), see Clause 7.2.8.

For cavity walls, the straps should be at 2m maximum centres, with the top strap near the apex of the gable. For solid walls, it will normally be necessary to fix the straps to the inside face with at least two 6mm x 30mm plug and screw fixings per strap.

Unless the design states otherwise, the restraint straps should be provided at:

- walls constructed of solid bricks — two restraint straps per roof slope at maximum 2m centres plus one extra strap near the apex of the gable
- walls constructed of perforated bricks/blocks or concrete/aerated concrete blocks — three restraint straps per roof slope at maximum 1.5m centres.

Note: for the purpose of lateral restraint, a 'perforated' brick/block is where the perforations (vertical holes) represent more than 25% of the volume of the brick/block.

10.1.9.4 Detailing at abutments

Precautions should be taken at abutments between a garage roof and the main building or between stepped garages, including:

- flashings and weatherproofing that allow for differential movement
- cover flashings formed from metal or other approved material
- cavity trays that divert water from inside the cavity to the external surface of the roof.

10.1.9.5 Movement

Movement joints in foundations and the structure should be continued through roof coverings and be provided with appropriate weather protection.

10.1.9.6 Adequate disposal of rainwater

The provision of rainwater should be in accordance with Building Regulations.

Individual roofs, or combinations of roofs that drain from one to another, with a total area greater than 6m², should have a rainwater drainage system.

Where rainwater from a large roof surface discharges onto a garage roof, precautions should be taken to prevent premature erosion of the lower surface.

Rainwater should not discharge from the roof directly to a drive or path.

For details on the design of rainwater disposal systems, reference should be made to the following chapters, as appropriate:

- 7.1 Flat roofs, terraces and balconies
- 7.2 Pitched roofs.

10.1.10 Permanent prefabricated garages and carports

Permanent prefabricated garages and carports shall be suitable for their intended purpose.

Permanent prefabricated garages and carports should:

- have appropriate foundations
- be structurally adequate
- provide appropriate weathertightness
- provide adequate separation between linked garages of different ownership.

Prefabricated garages should be erected in accordance with the manufacturer's recommendations.

Particular care should be taken to ensure adequate holding down of carports and other light structures against wind action.

10.1.11 Services

The provision of any service or appliance within a garage shall be in accordance with relevant regulations.

Issues to be taken into account include:

- 1) protection of water services against frost
- 2) provision of electricity
- 3) risk of fire or explosion.

Where services or appliances are provided in garages, they should comply with the guidance below and with the following chapters, as appropriate:

- 5.3 Drainage below ground
- 8.1 Internal services.

10.1.11.1 Protection of water services against frost

A rising main should not be located within a garage.

A water supply or outlet in a garage should have adequate provision for isolating and draining down.

Pipes should be insulated and located so as to minimise the risk of freezing.

10.1.11.2 Provision of electricity

The provision of electric lighting and socket outlets in a garage is at the discretion of the builder.

All electrical installations should comply with BS 7671.

Where there is a risk of rain penetration through garage walls, electrical wiring and equipment should be appropriate for the location and take account of conditions likely to be expected. For further guidance, see Clause 8.1.6.

10.1.11.3 Risk of fire or explosion

Installation in a garage of an oil or gas burning boiler or heating appliance should be in accordance with any relevant statutory regulations.

Where garages are to contain solar storage batteries, see Clause 8.2.1.



Chapter 10.2



Drives, paths and landscaping

This chapter provides guidance on meeting the Technical Requirements for drives, paths and landscaping, including:

- private roads
- shared private drives
- private drives
- car parking areas.

10.2.1	Compliance	02
10.2.2	Provision of information	02
10.2.3	Stability	02
10.2.4	Freestanding walls and retaining structures	02
10.2.5	Guarding and steps	03
10.2.6	Drives, paths and landscaping	03
10.2.7	Materials	08
10.2.8	Garden areas within 3m of the home	09
10.2.9	Garden areas	09
10.2.10	External decking	09
10.2.11	Landscaping	09



Figure reference table**Figure Reference Table 10.2**

Fig No	Title/Description	Clause	Page
Figure 1	Retaining structure requiring guarding	10.2.5	3
Figure 2	Transition adjustment requirements at top and bottom of steep gradients	10.2.6.1	4

Definitions for this chapter

Commercial vehicles	Commercial vehicles are typically vehicles weighing in excess of 3.5 tonnes or capable of moving a payload of more than 1 tonne. Examples are delivery trucks, buses, large vans, bin lorries, and fire trucks.
Flexible retaining walls	Are typically walls that support the soil laterally and allow larger deformations of the unsupported edge of the wall compared to stiff or rigid retaining walls. Typical examples of these include any or a combination of the following: vegetated such as geotextile bagged walls, earth-reinforced and most gravity retaining wall structures such as gabion, crib, block or modular retaining wall systems.
Garden	Is the land within the curtilage up to 20m from the habitable parts of the home (ie, not garages/ outbuildings). This distance is measured from the external walls.
Home	Includes a house, bungalow, flat or maisonette.
Light vehicles	Light vehicles are typically vehicles weighing up to 3.5 tonnes, and these include cars, SUVs, vans and minibuses.
Private drives	Are usually located adjacent to a property and typically within the curtilage of that property. Private drives and parking areas where located away from the immediate vicinity of a properties would usually have a barrier to ensure it is only used by cars and or light vehicles.
Private roads	Are roads that are unadopted or not maintained at public expense. They are usually wide enough for single traffic in opposite directions simultaneously, and may or may not have adjoining footpaths. Private roads will be expected to support frequent use by commercial vehicles.
Shared drives	Are usually single track private 'roads' to access private drives or private properties. Shared drives would be expected to support the occasional commercial vehicles on them.
Shared parking	Are typically communal parking area, which is accessible to the general public but are not adopted. There is usually little or no restriction regarding what type vehicles they are accessible to. They can sometimes act a turning head at the end of a public/ adopted road. Shared parking and access road/ areas to them are expected to support frequent use by commercial vehicles.

10.2.1 Compliance

Also see: Chapter 2.1

Drives, paths and landscaping shall comply with the Technical Requirements.

Drives, paths and landscaping that comply with the guidance in this chapter will generally be acceptable.

All works should be completed in accordance with:

- the design, and
- the ground remediation statement (where applicable).

Formation levels should be set out in accordance with the design.

10.2.2 Provision of information

Designs and specifications shall be produced in a clearly understandable format, include all relevant information and be distributed to the appropriate personnel.

All works relating to drives, paths and landscaping should be fully specified.

Design and specification information should be issued to site supervisors, relevant specialist subcontractors and suppliers.

10.2.3 Stability

Precautions shall be taken to ensure stability of the ground.

Where the ground may become surcharged during construction, precautions should be taken to ensure stability.

Flexible retaining walls such as gabion and timber structures should not be used to provide support to homes, garages, roads, drives, car parking areas or drainage systems.

Retaining structures that give support to the foundations of a home should be completed before work starts on the construction of the foundations of the home.

10.2.4 Freestanding walls and retaining structures

Freestanding walls and retaining structures shall be adequate for their intended purpose.

Freestanding walls should be in accordance with:

- BS EN 1996-1 Design of masonry structures — General rules for reinforced and unreinforced masonry structures
- PD 6697 Recommendations for the design of masonry structures.

Retaining structures should be in accordance with Table 1:

Table 1: British Standards, relevant codes of practice and authoritative documents

BS 8002	Code of Practice for earth retaining structures
BS EN 1992	Design of concrete structures
BS EN 1996	Design of masonry structures. All parts
BS EN 1997-2	Geotechnical design. Ground investigation and testing
BRE Good Building Guide 27	Building brickwork and blockwork retaining walls

All retaining structures, more than 600mm high, should be designed by an engineer in accordance with Technical Requirement R5.

Where timber structures more than 600mm high are used for retaining ground in boundary situations, they should be designed with a desired service life of 60 years and have a satisfactory third-party certification from an approval body acceptable to NHBC.

Where planters are provided, they should be designed to support the volume of retained soil and the plant species.

10.2.5 Guarding and steps

Retaining structures and steps shall be adequately guarded and allow safe use.

Guarding should be provided where:

- structures are retaining land more than 600mm high to which people have access
- a retaining structure is more than 600mm high and the dimension from the top of the retaining wall to the higher ground level is less than 300mm, or
- a path is adjacent to a vertical difference in level of more than 600mm (including where ground adjacent to the path falls away at an angle of more than 30° from the horizontal).

The guarding should:

- be a minimum of 1,100mm high
- not be readily climbable by children
- not allow a 100mm diameter sphere to pass through
- be capable of resisting a horizontal load of at least 0.36kN/m at its minimum required height, in accordance with BS 6180.

External steps that are not considered under Building Regulations should:

- have a maximum rise of 220mm
- have a minimum going of 220mm
- be reasonably uniform.

A handrail should be provided where the total rise of a flight of external steps is more than 600mm and the going of individual steps is less than 600mm.

For details of external staircases in and around dwellings, see Chapter 6.6 Staircases.

Guidance for the provision of handrails to steps that form an accessible approach can be found in supporting documents to Building Regulations.

10.2.6 Drives, paths and landscaping

Appropriate access (including private roads, shared private drives, private drives, car parking and paths) shall be provided to and around the home. Issues to be taken into account include:

- 1) general construction considerations
- 2) drainage
- 3) construction details
- 4) minimum sub-base thickness
- 5) house paths and patios.

Homes should be provided with suitable access through the provision of private roads, shared private drives, private drives, car parking areas and paths, as appropriate.

Figure 1: Retaining structure requiring guarding

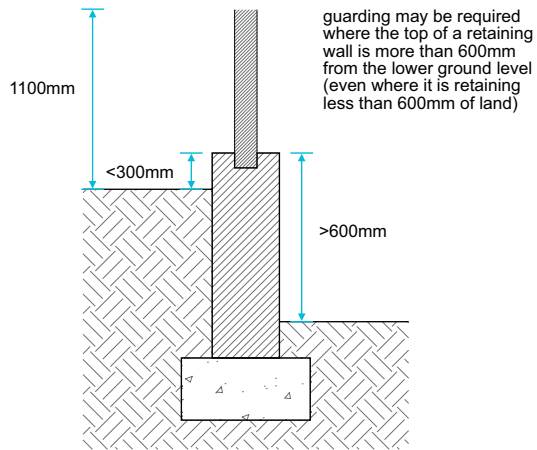

10.2.6.1 General construction considerations

Private roads, shared private drives, private drives, car parking areas and paths should comply with relevant Building Regulations. Where abutting the home, they should be at least 150mm below the DPC, and laid to falls away from the home (unless a channel or other suitable means of collection and disposal is provided).

All vegetable matter should be removed from the area of the proposed works.

Only suitable fill material comprising clean, well-consolidated crushed rock, hardcore, slag or concrete should be used to make up levels.

Sub-bases should be mechanically consolidated in layers not exceeding 225mm.

Finished ground levels should be compatible with:

- DPC levels
- cover levels of drainage access points
- depth of underground services (gas, electricity, water and drains)
- adjacent surfaces.

Private roads, shared private drives and private drives should:

- be appropriate for the loads
- provide reasonable access to and from a garage or car parking area
- have a maximum gradient of 1:6
- where the gradient is more than 1:10 and the gradient changes, have suitable transition lengths to reduce the risk of vehicles grounding.

Figure 2: Transition adjustment requirements at top and bottom of steep gradients

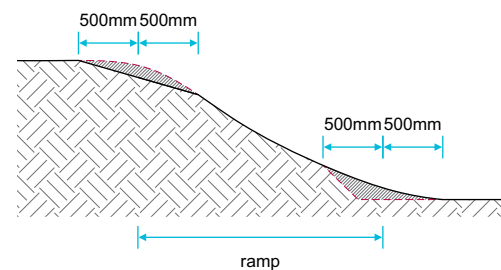

Underground drainage or services that are below a private road, shared private drive, private drive, car parking area, path or patio should be protected against damage, as described in Chapter 5.3 Drainage below ground.

Edge restraint or kerbing should have a profile and foundation, which is suitable to form a permanent supporting edge for the expected vehicle loads on the road or drive.

Pedestrian access should be provided via a path within the curtilage of each home to the main entrance and the secondary entrance where present:

- where entry to the home can be gained directly from a garage, a path to a secondary access door is not required
- where the secondary entrance is to a mid-terrace home or ground floor flat, a path to a secondary access door is not required
- where a garage, carport or car parking area is provided within the curtilage, a path should be provided to it from the home.

Where appropriate, a drive can be regarded as a path for the provision of access.

Paths should have a maximum slope of 1:6. On steeper sloping ground, steps may be required.

Table 2: Suitable path widths

Location and use	Minimum width of hard standing (mm)	Minimum overall width (mm)
Within curtilage to main entrance, or any entrance designated by Building Regulations	900	900
Paths used for the removal of refuse to the collection point	750	900
Paths adjoining a home (with hard standing 100mm or more from the wall of the home)	450	700
All other cases	450	600

10.2.6.2 Drainage

Private roads, shared private drives and private drives should have adequate rainwater drainage and disposal.

Paved areas should:

- have vertical alignment, finished levels, transition arrangements and gradients in accordance with the design
- have surfaces with adequate falls, cross-falls and drainage to ensure that surface water is suitably drained
- have sub-base levels with the same longitudinal gradient and cross-fall as the finished level
- have surfaces not flatter than 1:40 or have a camber of 1:40 where no fall is available to avoid 'flat spots'
- have surfaces with a minimum finished fall of 1:80 where they form private drives and paths
- drain away from the home (and garage), or drain to a channel or other suitable means of collection and disposal adjacent to the home
- not drain surface water from private areas onto adopted areas
- not be within 2m of a soakaway.

Where paving slabs are laid abutting drainage channels and gully grates, etc the upper surface of the paving slab should be set approximately 5mm above the grating.

Where it is intended to use porous or permeable surfaces as part, or all, of the rainwater drainage system, reference should be made to CIRIA Report C753 — The Sustainable drainage system (SuDS) manual.

10.2.6.3 Construction details

The construction of private roads, shared private drives, private drives and car parking areas should be constructed in accordance with the tables below and/or other published/approved design procedure.

Table 3a: Private road having frequent use by commercial vehicles

Construction — road type ⁽¹⁾		Road		Footpath
		Bituminous mixtures (asphalt)	Block pavers	Bituminous mixtures
Sub-base	MCHW Volume 1 SHW Clause 803 Type 1 Unbound mixtures Granular sub-base material Type 1 to Table 8/2	Table 4	Where California Bearing Ratio (CBR) is $\geq 5\%$ = 150 ⁽³⁾ Where CBR is less than 5% = Table 4	225mm ⁽³⁾
Base (road base)	Asphalt concrete to BS EN 13108-1 and PD 6691 using aggregate to BS EN 13043 and PD 6682-2	100mm (AC 32 dense base 100/150 des)	N/A	N/A
	Concrete designation (BS 8500-2:2015+A2:2019 Table 6)	N/A	N/A	N/A
Binder course (base course)	Asphalt concrete to BS EN 13108-1 and PD 6691 using aggregate to BS EN 13043 and PD 6682-2	60mm (AC 20 dense bin 100/150 des)	60mm (AC 20 dense bin 100/150 des)	60mm (AC 20 dense bin 100/150 des)
Surface course (wearing course)	Stone mastic asphalt to BS EN 13108-5 and PD 6691 with aggregate to BS EN 13043 and PD 6692-2	30mm (SMA 10 surf 40/60)	N/A	20mm (AC 6 dense surf 100/150 des)
	Hot rolled asphalt to BS EN 13108-4 and PD 6691 using aggregate to BS EN 13043 and PD 6692-2	40mm (HRA 55/10 surf 40/60 des)	N/A	N/A
	Concrete designation (BS 8500-2:2015+A2:2019 Table 6)	N/A	N/A	N/A
Bedding course	Coarse sand to BS 7533-3 category II of annex D	N/A	50mm	N/A
Pavers	Block pavers to BS EN 1338 of Class 2 weathering resistance and Class 3 abrasion, as well as being of low potential for slip (Ref: Table NA.2 of BS EN 1338) ⁽⁷⁾	N/A	80mm	N/A

Table 3b: Shared parking and associated access areas having frequent use by commercial vehicles

Construction — road type ⁽¹⁾		Bituminous mixtures (asphalt)	Block pavers
Sub-base	MCHW Volume 1 SHW Series 800 ⁽²⁾ Clause 803 Type 1 Unbound mixtures granular sub-base material Type 1 to Table 8/2	Table 4	Table 4
Base (road base)	Asphalt concrete to BS EN 13108-1 and PD 6691 using aggregate to BS EN 13043 and PD 6682-2	80mm (AC 32 dense base 100/150 des)	N/A
	Concrete designation (BS 8500-2:2015+A2:2019 Table 6)	100mm grade GEN2 ⁽⁴⁾	N/A
Binder course (base course)	Asphalt concrete to BS EN 13108-1 and PD 6691 using aggregate to BS EN 13043 and PD 6682-2	60mm (AC 20 dense bin 100/150 des)	N/A
Surface course (wearing course)	Stone mastic asphalt to BS EN 13108-5 and PD 6691 using aggregate to BS EN 13043 and PD 6682-2	30mm (SMA 10 surf 40/60)	N/A
	Hot rolled asphalt to BS EN 13108-4 and PD 6691 using aggregate to BS EN 13043 and PD 6682-2	N/A	N/A
	Concrete designation (BS 8500-2:2015+A2:2019 Table 6)	N/A	N/A
Bedding course	Sharp sand to BS 7533-3 category II of annex D	N/A	50mm
Pavers	Block pavers to BS EN 1338 of Class 2 weathering resistance and Class 3 abrasion, as well as being of low potential for slip (Ref: Table NA.2 of BS EN 1338) ⁽⁷⁾	N/A	80mm

Table 3c: Shared drives having infrequent use by commercial vehicles

Construction — road type ⁽¹⁾		Bituminous mixtures (asphalt)	Concrete	Block pavers	Gravel
Sub-base	MCHW Volume 1 SHW Series 800 ⁽²⁾ Clause 803 Type 1 Unbound mixtures granular sub-base material Type 1 to Table 8/2	Table 4	Table 4	Table 4	Table 4
Base (road base)	Asphalt concrete to BS EN 13108-1 and PD 6691 using aggregate to BS EN 13043 and PD 6682-2	⁽⁵⁾	N/A	N/A	N/A
	Concrete designation (BS 8500-2:2015+A2:2019 Table 6)	N/A	N/A	N/A	N/A
Binder course (basecourse)	Asphalt concrete to BS EN 13108-1 and PD 6691 using aggregate to BS EN 13043 and PD 6682-2	80mm (AC 20 dense bin 100/150 des ⁽⁶⁾)	N/A	N/A	N/A
Surface course (wearing course)	Stone mastic asphalt to BS EN 13108-5 and PD 6691 using aggregate to BS EN 13043 and PD 6682-2	30mm (SMA10 surf 40/60)	N/A	N/A	N/A
	Hot rolled asphalt to BS EN 13108-4 and PD 6691 using aggregate to BS EN 13043 and PD 6682-2	40mm (HRA 55/10 surf 40/60 des)	N/A	N/A	N/A
	Concrete designation (BS 8500-2:2015+A2:2019 Table 6)	N/A	150 grade PAV2	N/A	N/A
Bedding course	Sharp sand to BS 7533-3 category II of annex D	N/A	N/A	50mm	N/A
Pavers	Block pavers to BS EN 1338 of Class 2 weathering resistance and Class 3 abrasion, as well as being of low potential for slip (Ref: Table NA.2 of BS EN 1338) ⁽⁷⁾	N/A	N/A	80mm	N/A

Table 3d: Private drives and parking areas having use by cars and light vehicles

Construction - road type ⁽¹⁾		Bituminous Mixtures (asphalt)	Concrete	Block pavers	Gravel
Sub-base	MCHW Volume 1 SHW Series 800 ⁽²⁾ Clause 803 Type 1 Unbound mixtures granular sub-base material Type 1 to Table 8/2	Table 4	Table 4	Table 4	Table 4
Base (road base)	Asphalt concrete to BS EN 13108-1 and PD 6691 using aggregate to BS EN 13043 and PD 6682-2	N/A	N/A	N/A	N/A
	Concrete designation (BS 8500-2:2015+A1:2019 Table 6)	N/A	N/A	N/A	N/A
Binder course (base course)	Asphalt concrete to BS EN 13108-1 and PD 6691 using aggregate to BS EN 13043 and PD 6682-2	60mm (AC 20 dense bin 100/150 des)	N/A	N/A	N/A
Surface course (wearing course)	Asphalt concrete to BS EN 13108-1 and PD 6691 using aggregate to BS EN 13043 and PD 6682-2	25mm (AC 6 dense surf 100/150 des)	N/A	N/A	⁽⁸⁾
	Hot rolled asphalt to BS EN 13108-4 and PD 6691 using aggregate to BS EN 13043 and PD 6682-2	N/A	N/A	N/A	N/A
	Stone mastic asphalt to BS EN 13108-5 and PD 6691 using aggregate to BS EN 13043 and PD 6682-2	25mm (SMA 6 surf 40/60)	N/A	N/A	N/A
	Concrete designation (BS 8500-2:2015+A1:2019 Table 6)	N/A	100 grade PAV1	N/A	N/A
Bedding course	Sharp sand to BS 7533-3 category II of annex D	N/A	N/A	50mm	N/A
Pavers	Block pavers to BS EN 1338 of Class 2 weathering resistance and Class 3 abrasion, as well as being of low potential for slip (Ref: Table NA.2 of BS EN 1338) ⁽⁷⁾	N/A	N/A	50mm	N/A

Notes

- In the first column, European harmonised names for the pavement layers are with the old UK designations included in brackets.
- Where a capping layer is specified, sub-base thickness can be reduced. Pavement Design CD 225 Revision 1 gives guidance on capping and sub-base thickness design based on CBR values with and without a capping layer.
- For the minimum thickness of the sub-base for different CBR values, refer to Table 4.
- Bond coat in accordance with BS 594987 should be applied to ensure effective bonding of the asphalt layers.
- Bituminous mixtures/asphalt can be used as a partial replacement of a full thickness granular sub-base type 1 material.
- If the binder course is subjected to an extensive period of trafficking before the surface course is applied, a recipe mixture containing a higher bitumen content will be more durable/resistant to fretting/ravelling under traffic.
- Where laid to either a 90 or 45 degree herringbone pattern, the edge perimeter should be laid with one single row of stretcher bond set parallel to the edge restraint. Where block pavers are laid abutting drainage channels, gully grates, etc the upper surface of the block pavers should be set 3-6mm above the grating. Manufacturer's declared value markings W3 and S4 are acceptable. Where W3 is 1.0kg/m² or less and S4 is 45 or more based on 'C scale unit' (for abrasion, class A2 = maximum result is 23mm, class A1 = no performance determined).
- A 38mm thickness of graded 15/20mm unbound aggregate to BS EN 13242 (gravel), well rolled and compacted, should be used.
- Reference to clauses are in relation to the relevant European and/or British Standards.
- Asphalt contractors should be certified in accordance with the National Highway Sector Schemes for Quality Management in Highway Works — Scheme 16.

10.2.6.4 Minimum sub-base thickness

The thickness of any required capping layer and the sub-base should be determined after investigations and on-site tests have been carried out, with consideration to the:

- CBR value
- frost susceptibility of the sub-grade; where susceptible to frost, a suitable capping layer should be included below the sub-base to a suitable depth to ensure that the construction will not be affected by frost heave
- granular sub-bases should be tested and certified as being non-frost susceptible and non-plastic.

Table 4: Minimum sub-base thickness for paved areas

CBR values	Minimum thickness (mm) of sub-base ⁽¹⁾ (consolidated in accordance with MCHW Volume 1 Clause 801, Table 8/4)
Less than 2%	Subgrade requires improvement ⁽²⁾
2-<3%	325
3-<5%	250
5-<7%	150
7-20%	100

Notes

1. Minimum thickness of sub-base may be considered for reduction when using proprietary geogrid, provided they can be adequately justified and designed by an engineer in accordance with Technical requirement R5.
2. Specialist advice should be sought to improve the subgrade.

10.2.6.5 House paths and patios

The following construction will be generally acceptable for house paths and patios:

- the sub-base comprising of a 100mm thickness of clean, non-frost susceptible well consolidated crushed rock, hardcore (maximum size 50mm), slag or concrete, the surface of which is bladed with 25mm of sand
- paving slabs fully bedded in 25mm 1:4 cement:sand mortar or a suitable alternative.

Concrete paths and patios should be not less than 75mm thick and have a tamped or textured finish. The concrete mix should be suitable to give a durable and frost-resistant surface, as described in Chapter 3.1 Concrete and its reinforcement. Movement joints, not less than 10mm wide, should be provided across the full width of the path at not more than 4m centres. A movement joint is not required at the abutment with a wall unless the opposite edge of the concrete is also restrained.

10.2.7 Materials

Materials shall be suitable for their intended use. Concrete shall be of a mix design which will achieve sufficient strength for its purpose and be sufficiently durable to remain unaffected by chemical or frost action.

Sub-base material should be type 1 to Clause 803 Table 8/2, MCHW Volume 1 SHW Series 800.

Hot rolled and mastic asphalts and macadam should comply with relevant standards, including those in Table 5:

Table 5: British Standards and authoritative documents for asphalts

BS EN 13108-1	Bituminous mixtures. Material specifications. Asphalt Concrete
BS EN 13108-4	Bituminous mixtures. Material specifications. Hot Rolled Asphalt
BS EN 13108-5	Bituminous mixtures. Material specifications. Stone Mastic Asphalt
PD 6691	Guidance on the use of BS EN 13108
BS 594987	Asphalt for roads and other paved areas

Aggregates used in asphalt and macadam mixtures and unbound aggregate (graded 15/20mm gravel) for surfacing should comply with relevant standards, including those in Table 6:

Table 6: British Standards and authoritative documents for aggregates

BS EN 13043	Aggregates for bituminous mixtures and surface treatments for roads, airfields and other trafficked areas
PD 6682-2	Guidance on the use of BS EN 13043
BS EN 13242	Aggregates for unbound and hydraulically bound materials
PD 6682-6	Guidance on the use of BS EN 13242

Blocks, slabs, pavers, edgings, etc should comply with relevant standards, including those in Table 7:

Table 7: British Standards and authoritative documents for pavers

BS EN 771	Specification for masonry units
BS EN 1344	Clay pavers. Requirements and test methods
BS EN 1339	Concrete paving flags. Requirements and test methods
BS 7533	Pavements constructed with clay, natural stone or concrete pavers

Topsoil and subsoil should be of a quality that will not present a hazard to users of the garden area. BS 3882 (Topsoil), BS 8601 (Subsoil) and the Contaminated Land Exposure Assessment (CLEA) guidelines provide advice on determining the suitability of topsoil and subsoil.

10.2.8 Garden areas within 3m of the home

In order to provide for adequate access to and utility immediately around the home areas up to 3m from the habitable parts of the home shall not be waterlogged.

Waterlogging of garden areas within 3m of the habitable parts of the home should be prevented by appropriate soil selection and management, and if necessary, by drainage or other suitable means.

10.2.9 Garden areas

Garden areas within 20m of habitable accommodation shall be adequately prepared, stable and provided with reasonable access.

The stability of new or existing slopes in garden areas should be determined by an engineer in accordance with Technical Requirement R5. Alternatively, the following maximum gradients should apply:

- unsupported granular soil should be 5° less than its natural angle of repose
- unsupported cohesive soil should not exceed 9° (1:6).

Garden areas should have:

- old foundations, concrete bases and similar obstructions removed from within 450mm of the finished ground surface
- appropriate action, undertaken to restore physical condition (eg soil structure) and drainage characteristics of the topsoil and subsoil that has been compacted during construction. This should include subsoil decompaction, such as rotavating, to a minimum depth of 300mm and topsoil cultivation to the full depth of compaction. Further guidance is provided in BS 3882 on the depths, handling, management and preparation of topsoil and subsoil for landscaping
- ground disturbed during construction re-graded to conform to the general shape of the adjacent ground
- a minimum thickness of 100mm topsoil provided
- topsoil should be suitable for general landscape purposes and should also not contain contaminants which may present a hazard to the occupants
- topsoil that is disturbed or compacted after placement should be fully reinstated before planting, turfing or seeding.

Subsoil should not be placed over topsoil. Construction rubbish and debris should be removed from the garden and other areas around the home before topsoiling, and before or after planting, turfing or seeding.

Access is not required to small isolated garden areas, such as narrow strips of land at the top or bottom of retaining walls, but should be provided to other areas where appropriate by steps or other suitable means.

10.2.10 External decking

Also see: Chapter 3.3

Patios and decking shall be suitable for their purpose.

Timber decking, including support, should be naturally durable or treated with preservative to Use Class 4 classification.

Decking that is more than 600mm above ground level should be:

- in accordance with guidance published by the Timber Decking and Cladding Association (TDCA), or
- designed by an engineer in accordance with Technical Requirement R5.

Decking from other materials other than timber including wood composite materials and their support made from the same or similar materials, should be suitably durable and have the following:

- a satisfactory assessment by an independent technical approvals authority acceptable to NHBC and
- designed by an engineer in accordance with Technical Requirement R5.

10.2.11 Landscaping

Planting shall be completed in a manner appropriate for the site conditions and layout. Possible future damage to the home caused by planting shall be minimised.

Where trees or shrubs have been removed, are to be retained or are to be planted by the builder, precautions should be taken to reduce the risk of future damage to homes and services in accordance with Chapter 4.2 Building near trees.



Part 11

Modern Methods
of Construction



MMC Systems: general requirements

This chapter provides guidance on meeting the Technical Requirements for certification, quality management, site management, installation, verification, and handover requirements for MMC systems used to form homes where the height of the top floor above ground does not exceed 18m. This chapter should be used in conjunction with Chapters 11.2 and 11.3.

11.1.1	Compliance	03
11.1.2	Certification	05
11.1.3	System Manual	05
11.1.4	Quality management	07
11.1.5	Site management (handling, storage, and protection)	08
11.1.6	Structural design	10
11.1.7	Structural design checking and certification	10
11.1.8	Temporary stability, robustness, and integrity	11
11.1.9	Installation	11
11.1.10	Verification	13
11.1.11	Handover requirements	15

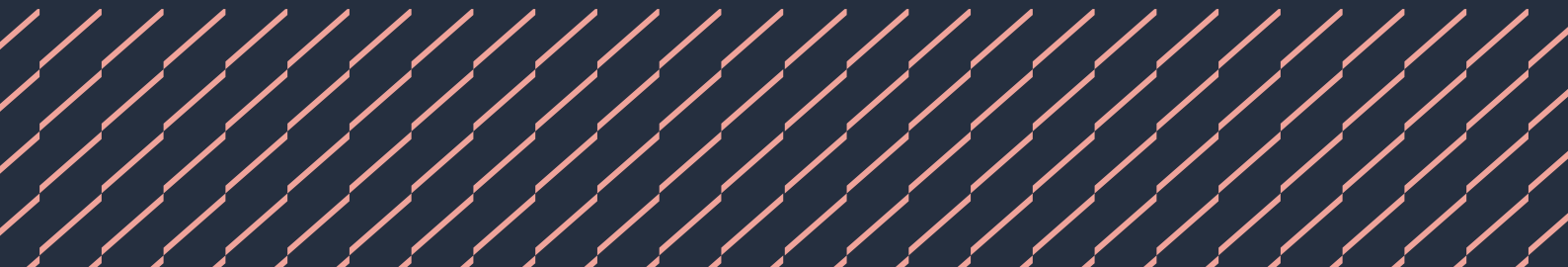

Figure reference table

Figure Reference Table 11.1

Fig No	Title/Description	Clause	Page
Figure 1	MMC process	11.1.1	4

Introduction

This chapter gives guidance on meeting the Technical Requirements for certification, quality management, site management (handling, storage, and protection), structural design, structural design checking and certification, installation, verification, and handover requirements for MMC systems used to form homes where the height of the top floor above ground does not exceed 18m.

The guidance in this chapter is intended to outline the common general requirements applicable to MMC systems manufactured in a factory environment. This chapter should be used in conjunction with Chapter 11.2 Closed panel systems and Chapter 11.3 Volumetric systems, where further guidance is given relevant to the system type being employed.

Users of this chapter should also refer to Part 6 of the NHBC Standards, particularly Chapters 6.2 and 6.10 when either timber frame or light steel frame respectively are to be used.

'Modern Methods of Construction' is a collective term encompassing a wide range of system types, including off-site manufactured systems that cannot be inspected on site in a traditional manner due to high levels of offsite fabrication, innovative technologies and other non-conventional methods of construction that form the structure and envelop of the home. As such, methods of construction that are described in the preceding chapters of the NHBC Standards, such as open panel light steel and timber frame, and can be inspected on site during the build process are considered as conventional construction rather than MMC.

MMC types have been categorised and defined in the MHCLG Cross Industry Working Group 'MMC Definition Framework'. The definition framework identifies the following seven MMC categories:

Category 1	Pre-Manufacturing — 3D primary structural systems
Category 2	Pre-Manufacturing — 2D primary structural systems
Category 3	Pre-Manufacturing — Non-systemised structural components
Category 4	Pre-Manufacturing — Additive Manufacturing
Category 5	Pre-Manufacturing — Non-structural assemblies and sub-assemblies
Category 6	Traditional building product led site labour reduction/productivity improvements
Category 7	Site process led labour reduction/productivity improvements

The guidance in this Part will focus on systems that fall under Category 1 ie, volumetric systems, and Category 2 (closed panel only) ie, panelised in the definition framework:

Category 1 — 3D primary structural systems (volumetric)

Three-dimensional structural volumetric units fabricated offsite in a factory environment used to form all or part of the basic structure of a building. Volumetric units may incorporate varying degrees of offsite fabrication and finish, including internal and external linings, external claddings, windows and doors, internal finishes, concealed insulation, membranes, internal services, internal fixtures and fittings and fire-stopping.

Volumetric units can be used in varying configurations to form the entire structure of the home or be supported by surrounding construction. Units can be manufactured in varying structural forms and be formed from timber, concrete, steel or light gauge steel or a combination of those materials.

Category 2 — 2D primary structural systems (panelised)

Flat two-dimensional panelised units fabricated offsite in a factory environment used to form walls, floors, and roof structures. The category encompasses panelised units supplied as 'open' or 'closed' panel, however the scope of this Part only encompasses 'closed' panel systems. Definition of 'closed' panel systems is given in Chapter 11.2 Closed Panel.

Definitions for this chapter

Cavity	A space enclosed by elements of a building such as the space between the cladding system and the backing wall. The external wall cavity should be adequately drained, and ventilated where required.
Cavity barrier	A construction within a cavity, other than a smoke curtain, to perform either of the following functions: <ul style="list-style-type: none"> • Close a cavity to stop smoke or flame entering • Restrict the movement of smoke or flame within a cavity.
Factory installed	An element of the construction that is placed, positioned, fitted, or secured in, on or as part of the unit as part of the factory construction process.
Fire-stopping	A seal provided to close an imperfection of fit or design tolerance between elements or components, to restrict the spread of fire and smoke.
Hold Point	A point in the manufacturing or construction process beyond which work may not proceed until the required inspection and verification has been undertaken.
Installation Manual	Detailed installation guidance and information for the system compiled by the system manufacturer. The Installation Manual describes general instructions for storage and transport of the system, and procedures for on-site assembly and installation.
MMC systems	Modern Methods of Construction is a collective term encompassing off-site manufactured systems that cannot be designed or be inspected on site in a traditional manner due to high levels of offsite fabrication, innovative technologies and other non-conventional methods of construction that form the structure and envelop of the home. As such, methods of construction that are described in the preceding chapters of the NHBC Standards and can be inspected on site during the build process are considered as conventional construction rather than MMC.
Manufacturer	The company which is responsible for the design and assembly of the MMC system.
Non-standard components	Components that are assembled as part of the system but vary for individual projects. These may be windows, doors or services that may be built into the system.
Robustness	A quality in a structure/structural system that describes its ability to accept a certain amount of damage without that structure suffering disproportionate failure. Robustness implies insensitivity to local failure.
Standard components	Components that are assembled as part of the system and are common to all projects.
Strong point	A structural element, frame or assembly oriented in a vertical plane that act to resist lateral loads supporting both horizontal and vertical stability systems together with façade (including wind posts, cladding rails, etc) and transfers the lateral actions through the assembly generally down to the foundation. Examples are reinforced concrete shear walls like lift cores or stair wells.
System	For the purposes of this chapter, this term refers to acceptable forms of either closed panel or volumetric MMC systems.
System Manual	Detailed technical information on the system compiled by the system manufacturer. The System Manual describes the system, the declared performance of the system and evidence to support the declared performance.
Unit	A prefabricated building element, manufactured offsite as a structural assembly in three-dimensional or flat panel format used as part of a system to form the superstructure of a building.
Volumetric	Three-dimensional structural units which are commonly stacked to form a building. Volumetric units may incorporate varying degrees of off-site fabrication and finish, including internal and external linings, external claddings, windows and doors, internal finishes, concealed insulation, membranes, internal services, internal fixtures and fittings and fire-stopping.

11.1.1 Compliance

Also see: Chapter 2.1

MMC systems shall comply with the Technical Requirements.

MMC systems should comply with the guidance in this chapter. Further reference should be made to relevant chapters ie, Chapter 11.2 Closed panel or 11.3 Volumetric, appropriate to the MMC system type being used.

Early engagement with NHBC should be undertaken prior to use of MMC systems on projects.

Figure 1: MMC process

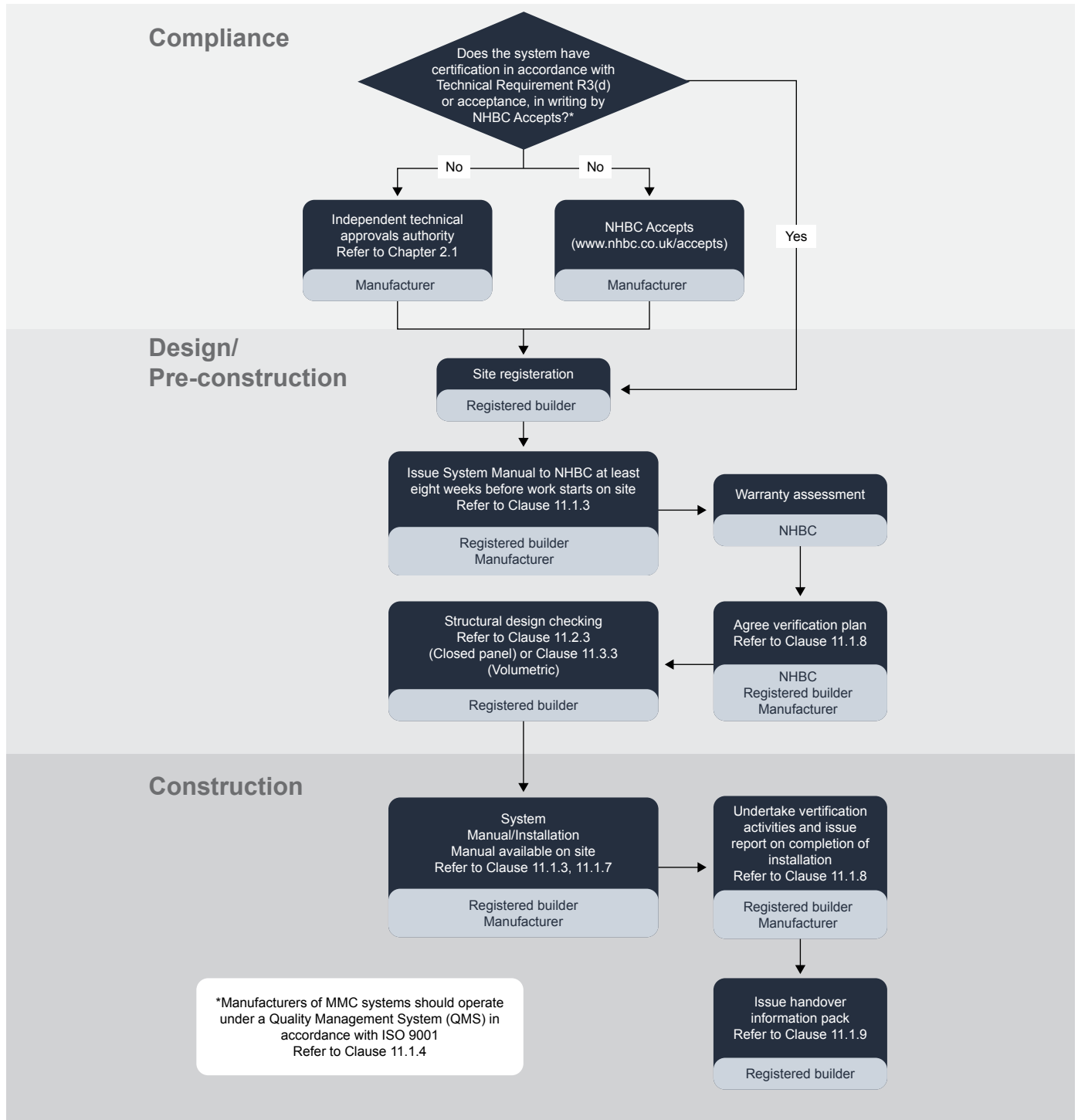

11.1.2 Certification

MMC systems shall be adequately certified as being suitable for their intended use.

MMC systems should have certification confirming satisfactory assessment, undertaken by an independent technical approvals authority, or acceptance in writing by NHBC Accepts.

The scope of certification by an independent technical approvals authority should include:

- inspection and surveillance of factory production
- strength and stability (including temporary loads)
- fire resistance including details of critical junctions between elements
- reaction to fire classification
- thermal performance
- acoustic performance
- system junctions and joints
- maintenance and reparability
- condensation risk
- resistance to weathering in use, including temporary resistance during transport and during construction
- regulatory compliance
- design considerations
- installation guidance and acceptable superstructure tolerances
- durability
- approval of installers.

Certification and system documentation should be:

- made available to NHBC before work begins on site, and
- used as a reference to ensure compliance.

Use of the system should be within the scope of the certification. Where relevant, certification should make reference to test evidence or documentation used to support or justify any declarations or conclusions made.

Standard components assessed as part of the system certification and performing critical functions should not be substituted or replaced unless agreed otherwise by NHBC.

11.1.3 System Manual

Designs and specifications, in the form of a System Manual, shall be produced in a clear and understandable format, include all relevant information, and be distributed to all appropriate personnel.

A System Manual and supporting design information should be issued to NHBC at least eight weeks in advance of the works starting on site, in accordance with NHBC rules. Further performance issues may be considered at the discretion of NHBC, and further information requested. If in doubt, consult NHBC Standards, Innovation and Research (technicalsupport@nhbc.co.uk).

The System Manual should contain the information described in Table 1 as relevant for the system.

Table 1: Items included in the System Manual

Topic	Description
System Details	<ul style="list-style-type: none"> • manufacturer name • system name • document revision number • issue date
Scope and limits of application	<ul style="list-style-type: none"> • description of the system and scope of offsite manufactured elements • intended use and limits of application or exclusions (geographic/environmental, storey height, dimensions, building type and shape, etc) • confirmation of parties, who have responsibility for the design and coordination of the system, certification of the system quality assurance and who has overall responsibility for the delivery of the home
Standard detail drawings	<ul style="list-style-type: none"> • schedule of standard detail drawings
Material specifications	<ul style="list-style-type: none"> • specifications and relevant third-party certificates for all key materials and standard components critical to the performance of the system
Durability	<ul style="list-style-type: none"> • demonstration of adequate durability of components and assemblies in accordance with Technical Requirement R3 • specification of fixings, including corrosion protection • temporary weather protection design and method

<p>Strength and stability</p>	<ul style="list-style-type: none"> ● structural design philosophy (including codes of practice referenced, test reports and identification of design aspects not covered by codes for which additional checks or assessment are required) ● sample structural calculations for typical design ● material strengths and/or grades (traceability) ● section properties ● loading ● ultimate limit state ● serviceability limit state ● resistance to overturning ● racking resistance ● holding down ● connections within the system ● connections with other building elements ● structural integrity ● positions and sizes of holes through members ● unit-to-unit connections (strength as well as accuracy) ● unit-to-foundation connections ● rigidity in transportation ● lifting
<p>Behaviour in relation to fire</p>	<ul style="list-style-type: none"> ● reaction to fire ● resistance to fire including fire test reports, and supporting assessments where required, demonstrating compliance with Building Regulations ● fire compartmentation design ● design and specification of cavity barriers and fire-stopping
<p>Resistance to moisture</p>	<ul style="list-style-type: none"> ● vapour permeability and moisture resistance of building fabric and suitable assessment of interstitial and surface condensation risk ● watertightness of the building envelope including integrity and continuity of building membranes and weather resistant detailing at junctions and interfaces ● resistance to moisture from the ground
<p>Safety in use</p>	<ul style="list-style-type: none"> ● consideration of changes in levels ● resistance to eccentric loads, including impact resistance
<p>Resistance to the passage of sound</p>	<ul style="list-style-type: none"> ● sound insulation performance and design
<p>Energy efficiency</p>	<ul style="list-style-type: none"> ● thermal resistance of building fabric including assessment of thermal bridging at typical junction and interface details ● air permeability design
<p>Coordination of services</p>	<ul style="list-style-type: none"> ● specification of factory installed services ● method of testing and commissioning ● method of access for site connections, inspection, and commissioning ● allowance for tolerances of site connections to factory installed services
<p>Quality of finish</p>	<ul style="list-style-type: none"> ● quality assurance process for achieving quality of finish in accordance with NHBC Standards
<p>Evaluation of conformity</p>	<ul style="list-style-type: none"> ● evidence of Quality Management System (QMS) in accordance with ISO 9001:2015 ● Factory Production Control (FPC) plan ● non-conformity procedure ● traceability and unit identification procedure ● inspection and test plan ● storage, transport, and installation procedures

11.1.4 Quality management

MMC systems shall be from a manufacturer operating under a quality management system acceptable to NHBC. Issues to be taken into account include:

- 1) factory production control
- 2) traceability of components and manufactured units
- 3) storage.

MMC systems must be supplied by a manufacturer who operates under a Quality Management System (QMS) which is certified by a UKAS accredited, independent certification body in accordance with the requirements of ISO 9001. The scope of the certified QMS should cover the following activities:

- design and development
- storage of goods and completed system units
- transportation
- externally provided products
- production controls
- identification and traceability
- site installation and handover.

Refer to Clause 11.1.9 for guidance on quality management of installation and handover.

11.1.4.1 Factory production controls

The manufacturer's Factory Production Control (FPC) plan should include:

- inspection and test plan, setting out the scope and frequency of inspection and testing of critical components
- description of controls between design and manufacture to demonstrate the accepted design is being produced
- traceability of all components used in the system
- process flow chart of activities, including change control mechanism
- process for identifying and resolving non-conformities
- hold points, evidence and method of inspection and documenting inspections.

Units formed from steel should be manufactured and installed in accordance with the relevant parts of BS EN 1090.

11.1.4.2 Traceability

MMC system units should be provided with a unique identifier in the form of an indelible Unit Identification Number (UIN), or unique digital marker containing a UIN affixed to the structure of the unit.

The indelible Unit Identification Number (UIN) should be accessible as far as practicable up to the point of handover. In addition:

- UINs or markers that can easily be damaged, dislodged or lost will not be acceptable
- digital markers should be of a type that can be easily read and accessed on site
- the location of UINs or markers should be indicated in the System Manual and Installation Manual
- as a minimum, the UIN should indicate the production number, unit descriptor (ie, unit type and variant), and date and place of manufacture.

The Unit Identification Number (UIN) should allow for traceability of all standard and non-standard components used to form the unit in accordance with the manufacturer's Quality Management System.

11.1.4.3 Storage

The manufacturer's Quality Management System (QMS) should provide suitable provision for long term storage of units at the manufacturing facility if required. Consideration should be given to:

- indoor, covered, or conditioned storage areas
- regular inspection of stored units
- records and tracking of storage duration
- exposure limits of protective materials.

Refer to Clause 11.1.5 for guidance on site storage requirements.

11.1.5 Site management (handling, storage, and protection)

Materials, products, and systems shall be handled, stored, and protected in a satisfactory manner to prevent damage, distortion, weathering, and degradation. Issues to be taken into account include:

- 1) storage
- 2) temporary weather protection
- 3) protection from damage during storage, transportation, and installation.

MMC systems should be:

- transported, lifted, handled, and stored in accordance with the manufacturer's recommendations, site installation manual and temporary weather protection method statement
- stored off the ground
- delivered in a sequence to avoid or minimise storage
- suitably protected against condensation, weathering and mechanical damage during storage, transport, and installation.

11.1.5.1 Storage

The storage of MMC systems should ensure:

- units are stored in accordance with the manufacturer's recommendations
- storage areas are clean and dry, level, and free from contaminants
- units are arranged and protected to prevent accumulation of trapped water
- units are arranged in sequence for erection, with markings visible and adequate access for lifting gear
- storage areas are suitably located, or protection provided to avoid staining and accidental damage by site traffic.

Packers or bearers placed under units should be located under stud positions or suitable bearing points in accordance with the manufacturer's recommendations.

Stacking

Where units are stacked on top of each other during storage, the storage area and bearing points should meet the required tolerances defined in the System Manual for foundations and be suitable packed and levelled to ensure no deformation of the structure. The System Manual should define:

- the maximum stacking height of units (ie the number of units that can be stacked on top of each other)
- method of temporary unit connections (for volumetric units) to ensure effective load transfer and resistance to sliding.

11.1.5.2 Temporary weather protection

The System Manual should include a moisture management plan to outline the design, method and controls for protecting the units from weather exposure and damage during storage, transport and installation. The plan should consider:

- details of any temporary openings that may be required in the protection layers (eg for lifting or installation/connection of units)
- continuity of temporary weather protection post installation
- method of sealing between units and around lifting/connection points
- method and timing for removal of temporary weather protection materials (materials left in situ post installation should be assessed for condensation risk in the permanent design).

To minimise the effect of condensation or moisture trapped within the unit, consideration should be given to:

- choice of materials used as temporary weather protection (ie, vapour resistivity of membranes)
- periodic condition inspections
- use of desiccant products
- storage time limits
- providing drainage points to allow trapped water to escape.

The System Manual should include details about any relevant exposure time limits. Exposure time limits should consider:

- maximum duration for external storage, and
- maximum duration of exposure following installation until permanent claddings are installed.

The performance of gypsum plasterboard linings can be significantly affected by wetting. Factory installed gypsum linings showing signs of facing paper delamination or mould growth due to construction moisture during the storage, transport or installation phase should be removed and replaced in accordance with plasterboard manufacturers recommendations, and the supporting structure checked.

Closed panel systems

Where timber and light steel framed walls incorporate linings or opaque membranes to both internal and external faces there is a risk of moisture being trapped within the frame void during the storage or construction phase. Consideration should be given to providing means of drainage to the base of panels to allow trapped moisture to escape.

Volumetric systems

The tops of volumetric units should be designed with adequate falls to avoid the risk of standing water. Water should be directed away from unit joints and cavities. Suitable provision should be made to provide temporary drainage to discharge to rainwater outlets or be designed to shed water clear from the building façade.

Materials used for sealing between units or around lifting points and temporary openings should be suitable for use in cold and wet conditions and UV resistant suitable for the exposure period.

Floors

Consideration should be given to the location of water-resistant membranes in floors (eg to the undersides of floors), and care should be taken to avoid the risk of trapped moisture within the floor structure.

Timber

Moisture content readings of structural timber to closed systems (including: closed panel timber frame, volumetric systems formed entirely of timber or volumetric systems incorporating timber frame backing walls and floors) should be undertaken as part of system verification activities, further guidance can be found in Clause 11.1.10.

SIPs

Panel edge protection should be provided at the base of SIP panels susceptible to moisture damage to prevent wicking of moisture from the floor during construction. If a panel becomes saturated during construction, specialist advice should be sought.

11.1.5.3 Protection from damage

MMC systems should only be handled in accordance with the manufacturer's recommendations, lifting methods and handling positions should be clearly defined.

To minimise risk of damage from handling of units, consideration should be given to the following:

- handling of units should be planned and reduced to a minimum
- packing should be used to ensure that scaffolding does not damage units during installation where panels incorporate factory installed external finishes
- protection to permanently exposed surfaces, especially arrises and decorative features with timber strips, hessian, or polyethylene.

Practical steps should be taken to avoid the risk of damage and staining to units and finishes during construction.

Internal finishes and fitments

Appropriate protection should be provided to all internal finishes and factory installed fitments (including to doors, trim, balustrades, panelling, and other special features) to ensure they are not damaged. Factory installed sanitaryware and kitchens, including cupboards, doors, fittings, and worktops, should be suitably protected.

11.1.6 Structural design

MMC systems shall be designed to support and transfer loads to foundations safely and without undue movement and shall have adequate resistance to all imposed loads. Issues to be taken into account include:

- 1) compliance with relevant standards
- 2) stability or resistance to lateral load
- 3) structural robustness.

11.1.6.1 Compliance with relevant standards

All load bearing elements should be designed to comply with relevant standards:

Basis of structural and geotechnical design	BS EN 1990 and relevant NA
Actions on structures	BS EN 1991, all parts and relevant NAs to these parts
Material codes	BS EN 1992 — EN 1999. Eurocodes for all materials and their relevant NAs
Low-rise building structures	BS 8103 (all parts)
Medium rise building structures of over three storeys high	Designed by an engineer in accordance with Technical Requirement R5
Structural robustness and mitigation of disproportionate collapse in buildings	BS EN 1991, all parts and relevant NAs to these parts Building Regulations — eg AD A in England & Wales IStructE's publication of Practical guide to structural robustness

11.1.6.2 Stability/resistance to lateral load

MMC systems forming homes or buildings containing homes shall be adequately designed to ensure that all loads are safely transferred to the foundations, without undue movement/distortion or impairing the health and safety of the building occupiers.

Whatever the system of resistance to lateral loads (ie, single material or hybrid system) that is being deployed for stability purposes, they should be demonstrated as being fit for purpose and within acceptable deflection limits for the type of structure and cladding used.

Effective connections of MMC modules or panels to any structural framing or strong point(s) used should be adequately provided and should be visible or inspectable. Where such connections are to be covered up in their final state, the installation is to be inspected and verified in accordance with the system verification plan (see Clause 11.1.10).

Manufacturing and erection tolerances should be clearly stated and allowed for in the design.

11.1.6.3 Structural robustness

MMC systems forming homes or buildings containing homes shall be adequately designed to ensure that the building is sufficiently robust to reduce the sensitivity of the building to disproportionate collapse in the event of an accident. This requirement will be considered met when the building is sufficiently robust to sustain a limited extent of damage or failure, depending on the consequence class of the building, without collapse. Further guidance can be found in The Institution of Structural Engineers publication 'Structural robustness and disproportionate collapse in buildings'.

11.1.7 Structural design checking and certification

MMC systems shall be adequately designed, checked and certified. The design of the MMC superstructure forming home(s) shall be adequately checked by an NHBC registered certifier.

Homes made from MMC systems to form the superstructure require certification confirming that the design of each house or apartment block has been satisfactorily checked by an NHBC registered MMC certifier.

MMC certifiers should:

- be listed on NHBC's list of MMC certifiers
- be a suitably qualified civil or structural engineer with a minimum of three years' experience in the use a particular MMC system or in the main components of the MMC system
- not be the designer of the MMC system or from the same firm as the designer of the MMC system
- complete and sign a certificate confirming assessment of structural adequacy for each specific project
- provide the registered builder with the completed and signed certificate to cover the different house(s) or apartment block(s).

The registered builder should ensure that the completed MMC certificate is available on site for inspection and a copy sent to the NHBC project manager.

Contact NHBC Standards, Innovation and Research via operationsupport@nhbc.co.uk

- if you require contact details of MMC certifiers, or
- to apply to become a MMC certifier.

11.1.8 Temporary stability, robustness, and integrity

MMC systems shall be sufficiently rigid to resist the forces imposed during transport, lifting and installation.

MMC systems should be sufficiently rigid to resist the forces imposed during transport, lifting and installation and prevent loosening of factory installed fire-resistant linings, claddings, cavity barriers and fire-stopping.

They should be provided with:

- designated anchorage or lifting points for lifting and securing during transport and installation
- suitable straps and/or frames to hold units safely in position during transport without undue movement
- temporary support or bracing to prevent excessive distortion and damage to the structure and finishes during transport and installation for units incorporating large openings.

Details of anchorage or lifting points and any temporary supports and their positioning should be included in the system Installation Manual and supporting drawings.

Consideration should be given to the design of racks and other equipment for large panels for transport with allowance made for the flexing of transport platforms.

11.1.9 Installation

MMC systems shall be installed in accordance with the manufacturer's recommendations and provide satisfactory performance. Installation instructions, in the form of an Installation Manual, shall be produced in a clear and understandable format, include all relevant information, and be distributed to all appropriate personnel. Issues to be taken into account include:

- 1) competence of installers
- 2) preparation
- 3) design, manufacture and erection tolerances
- 4) structural connections
- 5) sealing of joints and temporary openings.

A set of clear installation instructions should be submitted to NHBC, distributed to appropriate personnel, and made available on site in the form of a system Installation Manual and relevant accompanying drawings, detailing the assembly and installation of the system as appropriate. These instructions should cover factory and site assembly as required.

The system Installation Manual should:

- be supported with site-specific information, including drawings, or detailed fixing specifications
- be used as a reference to ensure compliance
- be current and specific to the system variant/type.

The system Installation Manual should contain the information described in Table 2 as relevant for the system.

Table 2: Items included in the Installation Manual

Topic	Description
Roles and responsibilities	<ul style="list-style-type: none"> • site process and responsibilities of key personnel • competence requirements for installers • duty holders for verification in accordance with the verification plan • key inspection stages and hold points in accordance with the verification plan — ie, hold points, checklists, provision and/or taking of photographic records
Scope and limits of application	<ul style="list-style-type: none"> • overview of the system including a description of key components and/or assemblies • confirmation of limits of application
Storage	<ul style="list-style-type: none"> • process for site storage and correct maintenance and removal of any temporary protection • method of providing adequate ventilation • requirement for periodic condition surveys
Tolerances	<ul style="list-style-type: none"> • clear description of tolerances for substructure (including square/dimensional/straightness & level) • clear description of dimensional tolerances for units and erection • clear description of tolerances for unit junctions and interfaces including cladding finishes
Pre-installation checks	<ul style="list-style-type: none"> • inspection and verification procedure for condition of units prior to and following delivery to site • tolerance survey of the substructure • dimensional survey of units pre-installation
Installation procedure	<ul style="list-style-type: none"> • sequence of erection • method of connecting to foundations • process and detail of structural connections — with a reference to either type, size, centres, quantity, specification of fixings and reference to bolts requiring specific torques (if standard) or reference to drawings for all module connections, panel joints, etc or where this information can be found on site • temporary bracing requirements (if applicable) • checks and verification procedures associated with cavity barriers and fire-stopping • method and verification for the sealing and completion of junctions between units • method and verification procedure for sealing of temporary roofing membranes including temporary openings and lifting points and adequate drainage provision • detail about removal of temporary protection (unless included in the design as part of the system) • tolerance survey of installed units (level/plumb/deviation)
Services	<ul style="list-style-type: none"> • method for connection of building services such that fire protection and damp proofing are not compromised • method for making good of service connection access points in the structure • method for commissioning of services
Non-conformities	<ul style="list-style-type: none"> • remedial action procedure for damaged or non-conforming units

11.1.9.1 Competence of installers

Installation of MMC systems should be carried out by trained and competent installers. Specialist installers should understand storage and handling procedures, tolerances, and installation methods relevant to the system type, and have been provided with all product technical data sheets and installation guidance documentation.

Systems should be installed by operatives who:

- are competent
- are familiar with the system being installed
- are registered or hold a current and valid certificate confirming that they have been trained by the system manufacturer, supplier, or installer.

11.1.9.2 Preparation

A pre-installation survey of both the foundations and surrounding construction should be undertaken to ensure compliance with the product specification requirements prior to installation of units.

Volumetric systems

A pre-installation survey of service entry points and pop-ups (eg below ground drainage) should be undertaken prior to installation of units to ensure they align.

11.1.9.3 Design, manufacture and erection tolerances

MMC systems should be installed, within reasonable tolerances, in accordance with the design and as defined in the system Installation Manual.

Units should be checked to ensure that they are dimensionally accurate and not deformed in shape before erection commences.

Closed panel systems

Timber frame walls should be installed in accordance with the relevant tolerances in Clause 6.2.4.

Light steel frame walls should be installed in accordance with the relevant tolerances in Clause 6.10.10.

SIPs should be installed in accordance with the System Manual and certification requirements.

11.1.9.4 Structural connections

MMC unit connections should be installed in accordance with the design.

The supporting structure may have local deviations in level along its length or at individual base plate locations, and packing will be required to achieve the required tolerances and to provide for effective load transfer. The type and extent of packing should be in accordance with the System Manual.

Volumetric systems

Connection plates and brackets should not be drilled, cut, or welded unless required by the design.

11.1.9.5 Sealing of joints

Only the materials and method specified in the design should be used for sealing of joints between units and temporary openings. Tapes, sealants, and membranes should be installed in accordance with manufacturer's instructions.

Before joints between units or temporary openings are sealed, installers should ensure:

- all cavities are dry
- all surfaces are clean and dry
- insulation is complete
- cavity barriers and fire-stops have been installed.

11.1.10 Verification

Documentation shall be provided in a clear and understandable format to confirm that the system has been supplied and installed in accordance with the System Manual and the design.

In addition to system certification and structural design checking (see Clause 11.2.3 and 11.3.3), NHBC requires verification, comprising documentation in a clearly understandable format, to show that MMC systems have been manufactured, stored, transported, and installed:

- in accordance with the design
- in accordance with the Quality Management System (QMS)
- to an acceptable standard
- in accordance with the System Manual and manufacturers instructions
- in accordance with statutory requirements.

Verification plan

A verification plan should be provided to NHBC before construction works commence on site.

The verification plan should:

- name duty holders
- define competence and responsibilities of duty holders during the factory production and construction phase
- outline key inspection stages and hold points, covering pre-installation, installation, and post-installation phase checks
- refer to the System Manual and system Installation Manual.

Verification reports should clearly state which elements of the system have or have not been subject to inspection and verification. The report should also record where verification is based on photographic evidence or other information supplied by a third-party.

Systems are assigned risk categories according to the complexity of the system and installation, see Table 3.

Table 3: System risk categories

Risk category	System type
1	Closed panel (no factory installed external claddings) — See Chapter 11.2
2	Closed panel (factory installed external claddings) — See Chapter 11.2
3	Volumetric (houses up to 4 storeys) — See Chapter 11.3
4	Volumetric (apartment buildings and buildings above 4 storeys) — See Chapter 11.3

The verification reporting requirements will be appropriate for the risk category of the system. Inspection stages and verification requirements will vary according to the system but should consider activities listed in Table 4. The manufacturer should determine the verification activities appropriate to the system, and present these in the verification plan for submittal to, and agreement by NHBC.

Table 4: Verification stage activities

Verification inspection stage activities	Risk category			
	1	2	3	4
Storage				
• regular condition survey of units in storage	•	•	•	•
• suitability and condition of storage areas	•	•	•	•
Transport				
• secure fixing to transport or support in transport stillage	•	•	•	•
• adequate bracing of openings	•	•	•	•
• temporary weather protection	•	•	•	•
Pre-installation				
• recording of delivery dates for individual units	•	•	•	•
• damage/condition inspection of units	•	•	•	•
• visual inspection and moisture readings of structural timber elements (if applicable)	•	•	•	•
• dimensional, square, straightness and level check of substructure and surrounding construction	•	•	•	•
• dimensional and square check of panels	•	•	•	•
Installation				
• recording of installation dates for individual units	•	•	•	•
• unit to foundation connections	•	•	•	•
• unit to unit connections	•	•	•	•
• connections of secondary elements eg balconies (if applicable)	•	•	•	•
• unit to surrounding construction (eg building core, staircases, roof, etc) connections	•	•	•	•
• temporary/permanent weather sealing of unit junctions	•	•	•	•
• installation of cavity barriers and fire-stopping	•	•	•	•
• location referenced photographic records of concealed fire-stopping		•	•	•
• service connections			•	•
• third-party verification (if required)				•
Post-installation				
• visual inspection and moisture readings of structural timber elements (if applicable)	•	•	•	•
• survey of top of units (ie standing water)			•	•

For systems incorporating specialist materials or complex construction methods not covered by NHBC Standards that are critical to the structural stability of the building, NHBC may also require additional verification from an independent third-party engineer in accordance with Technical Requirement R5.

Suitable persons for the level of verification

The manufacturer of the system should specify the requirements for specialist installers and verifiers.

The manufacturer should clearly establish the roles and responsibilities of verifiers within the verification plan, recognising that installation teams may be responsible for providing information to support the overall verification strategy for the system (for example concealed fire-stopping and cavity barriers or tolerance surveys).

The registered builder’s site team should be fully aware of the installation procedures and hold points for inspection.

11.1.11 Handover requirements

Clear information about the system and guidance on its future use or maintenance shall be provided to the homeowner.

A pack of handover information should be provided to the homeowner. The pack of information should be in a format intended for a non-technical user and include:

- user-friendly description of the building system
- method statement for the replacement of materials and components with a lesser durability that will require replacement during the lifetime of the home
- maintenance requirements
- product data sheets or relevant certification for key components that make up the building system
- contact details for the manufacturer.



Chapter 11.2



Closed Panel systems

This chapter gives guidance on meeting the Technical Requirements for closed panel systems used to form homes where the height of the top floor above ground does not exceed 18m.

11.2.1	Compliance	03
11.2.2	Provision of information	04
11.2.3	Structural design	04
11.2.4	Structural design checking and certification	04
11.2.5	Behaviour in relation to fire	05
11.2.6	Acoustic performance	05
11.2.7	Differential movement	06
11.2.8	Protection from moisture	06
11.2.9	Insulation	08
11.2.10	Junctions and interfaces	09
11.2.11	Cladding	10
11.2.12	Doors, windows, and glazing	12
11.2.13	Air and vapour control layers	13
11.2.14	Breather membranes	14
11.2.15	Sheathing boards	14
11.2.16	Wall ties	15
11.2.17	Services	15
11.2.18	Further information	15



Figure reference table**Figure Reference Table 11.2**

Fig No	Title/Description	Clause	Page
Figure 1	Straightness of interface joint widths	11.2.11.4	11
Figure 2	Taper of interface joints	11.2.11.4	11
Figure 3	Offset of cladding faces	11.2.11.4	12
Figure 4	Accuracy of cruciform interface joints	11.2.11.4	12

Introduction

This chapter gives guidance on meeting the Technical Requirements for closed panel systems used to form homes where the height of the top floor above ground does not exceed 18m. For the purposes of this chapter, closed panel systems shall include:

- timber framed wall and floor panels
- light gauge steel framed wall and floor panels
- Structural Insulated Panel (SIPs) walls.

The guidance in this chapter does not apply to roof cassette systems or pre-manufactured panels formed from mass engineered timber, hot rolled steel or precast concrete. It also does not apply to use of the systems below ground level.

This chapter should be used in conjunction with Chapter 11.1 MMC systems: general requirements. This chapter seeks to focus on areas of guidance that are unique to the system type and method of construction employed, giving references to complimentary existing guidance provided elsewhere in the Standards where relevant.

There is a strong link to all chapters in Part 6 of the Standards, particularly Chapters 6.2, External time framed walls and 6.10, Light steel framed walls and floors.

The term 'Modern Methods of Construction (MMC)' is very broad and covers a wide range of differing offsite manufactured systems and onsite construction techniques.

MMC types have been categorised and defined in the MHCLG Joint Working Group 'MMC Definition Framework', see Chapter 11.1 MMC systems: general requirements. The scope of the guidance in this chapter will cover 'closed' panel systems that generally fall under Category 2 under the MMC Definition Framework and as defined below.

Definitions of Open and Closed panel

MMC Category 2 light gauge steel and timber frame building systems are typically constructed from panels manufactured offsite under factory-controlled conditions. The extent of prefabrication can vary, with panels being as simple as studs and sheathing, or include external cladding, internal linings, windows and services. Where building systems utilise high levels of offsite prefabrication, traditional site inspection regimes for installation of critical materials, junctions and components are not possible. In addition, the greater the level of factory prefabrication, the greater the potential risks associated with exposure to moisture during construction.

Whilst the extent of offsite prefabrication can vary significantly, light gauge steel and timber frame building systems are typically categorised by NHBC as either 'open panel' or 'closed panel'. For the purpose of Warranty provision, NHBC's definitions are set out below.

Open Panel

Flat two-dimensional panelised units fabricated offsite in a factory environment used to form wall and floor structures.

Open panel assemblies typically include:

- a structural frame of studs and joists
- floor decking and sheathing boards as required.

Additionally, open panel assemblies may also include:

- a fixed breather membrane to external walls
- insulation (between the studs only)
- a transparent air and vapour control layer (AVCL) in order that the construction/insulation can be viewed on site (note — if a non-transparent air and vapour control layer is used, the system will be considered by NHBC as being closed panel)
- battens forming a service zone
- temporary weather protection.

Closed Panel

Closed panel systems are also defined as flat two-dimensional panelised units fabricated offsite in a factory environment used to form wall and floor structures, but in addition to the items set out above for open panel systems, where any one of the following items are factory fitted NHBC will consider the system to be closed panel:

- non-transparent air and vapour control layer
- sheathing boards to both sides of panels
- internal linings (such as plasterboard)
- continuous insulation installed to either the inner or outer face of the panels
- external cladding or finishes
- windows and doors
- fixed services such as plumbing pipes and electrical cables
- cavity barriers and/or fire stopping.

Guidance for traditional open panel construction formed from timber or light steel frame is given in Chapter 6.2 External timber framed walls and 6.10 Light steel framed walls and floors.

Definitions for this chapter

Cavity	A space enclosed by elements of a building such as the space between the cladding system and the backing wall. The external wall cavity should be adequately drained, and ventilated where required.
Cavity barrier	A construction within a cavity, other than a smoke curtain, to perform either of the following functions: <ul style="list-style-type: none"> ● close a cavity to stop smoke or flame entering ● restrict the movement of smoke or flame within a cavity.
Closed panel	Flat two-dimensional panelised units fabricated offsite in a factory environment used to form wall and floor structures, including where any one of the following items are factory fitted: <ul style="list-style-type: none"> ● non-transparent air and vapour control layer ● sheathing boards to both sides of panels ● internal linings (such as plasterboard) ● continuous insulation installed to either the inner or outer face of the panels ● external cladding or finishes ● windows and doors ● fixed services such as plumbing pipes and electrical cables ● cavity barriers.
Factory installed	An element of the construction that is placed, positioned, fitted, or secured in, on or as part of the unit as part of the factory construction process.
Fire-stopping	A seal provided to close an imperfection of fit or design tolerance between elements or components, to restrict the spread of fire and smoke.
Floor cassette	Flat two-dimensional panelised units fabricated offsite in a factory environment used to form a load-bearing element of floor construction. Typically includes a series of floor joists joined together with trimmers or end-joists and floor decking.
Installation Manual	Detailed installation guidance and information for the system compiled by the system manufacturer. The Installation Manual describes general instructions for storage and transport of the system, and procedures for on-site assembly and installation.
Interface	Interface either between similar or dissimilar envelope systems (eg at panel joints) or between envelope systems and other elements of the building (eg walls, roof, doors, and windows).
Junction	The point where components, including panels are joined with each other or with other elements of the building (eg supporting structure, roofs and foundations).
Manufacturer	The company which is responsible for the design and assembly of the closed panel system.
Non-standard components	Components that are assembled as part of the system but vary for individual projects. These may be windows, doors or services that may be built into the system.
Primary structural components	Elements of the structure designed to carry and transfer primary loads of the building, including self-weight, dead loads, and live loads.
Secondary structural components	Elements of the structure which do not play a wider role in the structure, but carry loads directly imposed on them (and transfer them to the primary structure) such as self-weight, wind loads, cladding and openings.
Standard components	Components that are assembled as part of the system and are common to all projects.
System	For the purposes of this chapter, this term refers to acceptable forms of closed panel systems.
System Manual	Detailed technical information on the system compiled by the system manufacturer. The System Manual describes the system, the declared performance of the system and evidence to support the declared performance.
Unit	A prefabricated building unit, manufactured offsite as a structural or non-structural assembly in three-dimensional or flat panel format used as part of a system to form the superstructure of a building.

11.2.1 Compliance

Also see: Chapters 2.1 and 11.1

Closed panel systems shall comply with the Technical Requirements.

Closed panel systems that comply with the guidance in this chapter and associated chapters will generally be acceptable. This chapter should be used in conjunction with guidance in Chapter 11.1 MMC Systems: general requirements.

As many components of closed panel systems cannot be inspected on site, they should be treated as a building system as defined in Chapter 2.1, Standards and Technical Requirements and subject to assessment by an independent technical approvals authority or assessed under the NHBC Accepts service; www.nhbc.co.uk/accepts.

11.2.2 Provision of information

Also see: Chapter 11.1

Designs and specifications shall be produced in a clearly understandable format, include all relevant information, and be distributed to all appropriate personnel.

Design, specification and installation information should be issued to site supervisors, relevant specialist subcontractors and suppliers, and be made available on site to enable work to be carried out in accordance with the design. This should include:

- a System Manual (see Clause 11.1.3)
- clear, coordinated and fully detailed drawings providing sufficient information for construction and installation of the system
- a system Installation Manual (see Clause 11.1.9).

Refer to Chapter 11.1 MMC Systems: general requirements for further guidance.

11.2.3 Structural design

Also see: Chapters 6.2, 6.3, 6.4 and 6.10

Closed panel systems shall be designed to support and transfer loads to foundations safely and without undue movement and shall have adequate resistance to loads imposed during manufacture, transportation, and installation.

Closed panels should be securely fixed together and securely fixed to the floor and roof framing and surrounding construction.

Connections between closed panel and between closed panels and surrounding construction should:

- be designed to be structurally adequate
- include clear method of connection in the System Manual and Installation Manual
- be designed to avoid the risk of damaging or compromising the functional performance of factory installed elements such as breather membranes, AVCLs and lining boards.

Closed panel timber frame

The design of structural walls should be in accordance with Chapter 6.2 External timber framed walls. Load-bearing internal walls should be designed in accordance with Chapter 6.3 Internal walls, and floors should be designed in accordance with Chapter 6.4 Timber and concrete upper floors.

Structural insulated panels (SIPs)

The design of SIPs should be in accordance with the independent technical approvals authority certification. The scope of the certification should consider the design of a structure using the system, including panel connections and connections with other supporting elements such as intermediate floors, and not the panels in isolation.

Load-bearing internal walls should be designed in accordance with Chapter 6.3 Internal walls, and floors should be designed in accordance with Chapter 6.4 Timber and concrete upper floors.

Closed panel light steel frame

The design of structural walls, structural floors and overall stability should be in accordance with Chapter 6.10 Light steel framed walls and floors.

Temporary loads

Structural design of the units should consider the loads imposed during manufacture, storage, lifting and transportation and provide sufficient stiffness or protection against inadmissible deformation or deflection. See also Clause 11.1.8.

Where required, the design should specify temporary bracing and/or additional support arrangements for large openings or weak points in the structure and clearly identify the conditions under which such works can be removed.

11.2.4 Structural design checking and certification

Also see: Chapters 6.2 and 6.10

The closed panel system shall be adequately designed and the design certified. Design of the superstructure shall be adequately checked by an NHBC registered certifier.

Closed panel timber frame

Structural design checking and certification should be in accordance with Clause 6.2.3.

Structural insulated panels (SIPs)

Structural design checking and certification should be in accordance with Clause 6.2.3 where SIPs incorporate structural timber.

Closed panel light steel frame

Structural design checking and certification should be in accordance with Clause 6.10.3.

11.2.5 Behaviour in relation to fire

Closed panel systems shall have adequate fire resistance and resist the spread of fire and smoke. Issues to be taken into account include:

- 1) fire resistance of the unit or panel
- 2) cavity barriers and fire-stopping
- 3) services.

Guidance within supporting documents to Building Regulations should be fully considered in the design and construction of closed panel systems.

The design and System Manual should clearly define:

- the overall fire protection strategy of the system
- which elements of fire protection are either factory or site installed.

11.2.5.1 Fire resistance of the unit or panel

Walls and floors should have adequate fire resistance in accordance with Building Regulations, supported with representative test evidence to appropriate standards.

The performance of specific details should be taken into account, including:

- fire protection to the structure around openings
- junctions between adjacent panels and interfaces of wall and floor panels
- compartmentation including interfaces with fire doors and junctions with adjoining building elements
- service openings, voids and penetrations.

Structural insulated panels (SIPs)

Lifting holes should be filled and sealed using a material providing the same level of protection as the material removed.

11.2.5.2 Cavity barriers and fire-stopping

The provision and installation of cavity barriers and fire-stopping should:

- be in accordance with Building Regulations and the design
- be designed to accommodate ventilation or drainage paths
- be used in accordance with manufacturers recommendations
- account for movement in the frame
- be specified to accommodate design, manufacturing and installation tolerances.

Moisture protection should be provided to horizontal and vertical cavity barriers.

Detailing and specification of cavity barriers and fire-stopping should be in accordance with the manufacturer's recommendations and supported with representative test evidence to appropriate standards.

11.2.5.3 Services

Only the services shown in the design should be installed in closed panel system floors and walls, and:

- service penetrations should not impair the fire resistance of floors and walls
- service mains should not pass through separating wall cavities.

11.2.6 Acoustic performance

Also see: Chapters 6.2, 6.3, 6.4 and 6.10

Closed panel system walls and floors shall have adequate resistance to the passage of sound.

Separating walls and floors should be in accordance with Building Regulations. In England, Wales, and Northern Ireland, separating walls and floors may be built in accordance with Robust Details 'Resistance to the passage of sound' as an alternative to pre-completion sound testing.

Separating walls and floors should be in accordance with the design. Care should be taken to avoid gaps:

- between mineral wool quilt or batts
- between internal lining board layers
- between cavity barriers
- around openings for services.

Internal walls should be in accordance with Clause 6.3.7

Proprietary partitions

Closed panel systems when used as proprietary partitions should be independently assessed or tested for 'sound transmission' performance in compliance with Technical Requirement R3.

11.2.7 Differential movement

Also see: Chapters 6.2 and 6.10

Buildings formed using closed panel systems shall account for differential movement between the frame wall and other building elements or supporting structures.

Where closed panel systems connect to surrounding construction and differential vertical movement is expected, consideration should be given to:

- accommodation of suitable movement joints in self-supporting and lightweight claddings
- the design of joint details and accommodation of differing floor levels at thresholds at staircases and lift shaft enclosures
- service entries, risers and fixed vertical external services
- design and provision of suitable weather resistant and durable joints
- interface of self-supporting cladding and cladding attached to the unit
- design of connection brackets, anchors, and ties to accommodate movement.

Where claddings are factory installed and supported by the panel, consideration should be given to interfaces with self-supporting cladding.

Closed panel timber frame

The design for differential movement in closed panel timber frame structures should be in accordance with Clause 6.2.8.

Structural insulated panels (SIPs)

SIPs not incorporating structural timber should be designed in accordance with the manufacturer's recommendations.

The design for differential movement in SIP structures incorporating structural timber should be in accordance with Clause 6.2.8.

Closed panel light steel frame

The design for differential movement in closed panel light steel frame structures should be in accordance with Clause 6.10.20.

11.2.8 Protection from moisture

Also see: Chapters 5.1, 6.1, 6.2, 6.10 and 11.1

Closed panel systems shall be adequately protected from the effects of moisture. Details of closed panel systems at low level shall fully consider the durability of materials, protection of the building from moisture ingress and condensation as a result of thermal bridging. Issues to be taken into account include:

- 1) cavities in external walls
- 2) protection at low level
- 3) DPCs, DPMs and cavity trays
- 4) junctions between adjoining panels.

Guidance on temporary weather protection can be found in Clause 11.1.5. Guidance on moisture management strategies for structural timber buildings can be found in Structural Timber Association publication 'Moisture management strategy'.

11.2.8.1 Cavities in external walls

A clear cavity in accordance with Table 1 should be provided between the cladding and insulation.

Table 1: Minimum cavity widths

Cladding	Cavity width
Masonry	50mm
Render on board background	25mm
Vertical tile hanging ⁽¹⁾ where a breather membrane is provided and fixed to sheathing	Dependant on batten support layout and spacing ⁽¹⁾
Other cladding ⁽¹⁾	See Chapter 6.9 Curtain walling and cladding

Notes

1. See Chapter 6.9 Curtain walling and cladding.

Cavities should be:

- drained (for light steel frame walls)
- extend at least 150mm below DPC
- drained and vented (for timber frame and SIP walls)
- be kept clean, free from obstructions and capable of draining freely.

Closed panel timber frame walls

Cavities to closed panel timber frame walls should be in accordance with Clause 6.2.10.

Structural insulated panels (SIPs)

Cavities to SIP walls should be in accordance with Clause 6.2.10.

Closed panel light steel frame walls

Cavities to closed panel light steel frame walls should be in accordance with Clause 6.10.16.

11.2.8.2 Protection at low level

Closed panel timber frame and structural insulated panels (SIPs)

The lowest timber should be a minimum of 150mm above finished ground level. This may be reduced to 75mm in situations where the site is not subject to a high water table or where the cavity will not have standing water.

DPCs should be installed below the sole plates of walls and ground floor internal partitions.

Where external ground levels are raised locally to accommodate accessible entrances, consideration should be given to the following:

- appropriate drainage installed along the perimeter or ground falling away from the building
- adjacent surface finishes which do not promote splashing
- additional cavity ventilation either side of raised ground levels
- use of a 'kerb' or 'upstand' to raise level of timber frame elements.

Closed panel light steel frame

The protection of light steel frame at low level should be in accordance with Clause 6.10.16.

11.2.8.3 DPCs, DPMs and cavity trays

Damp proofing should:

- be installed correctly to provide a physical barrier to the passage of water, and to ensure water is directed to the outside
- use only appropriate tapes and sealant (but not solely rely on sealant) in accordance with the design and manufacturer's recommendations
- use DPCs/DPMs where necessary, including junctions between systems and any other component or systems.

DPCs

The following materials are acceptable for use as DPCs:

Bitumen-based materials	BS 6398, BS EN 14967
Polyethylene (except as cavity trays in walls, below copings and in parapets)	BS 6515, BS EN 14909
Proprietary materials	Technical Requirement R3
Thermoplastics and Elastomers	BS EN 14909

DPMs

Where DPMs are required, they should be linked with any DPCs in the supporting structure, in order to provide continuous protection from moisture from the ground or through the supporting structure.

DPMs should be properly lapped in accordance with Chapter 5.1 Substructure and ground-bearing floors.

Suitable materials for DPMs include:

- 1,200-gauge (0.3mm) polythene sheet
- minimum 1,000-gauge (0.25) polythene sheet where assessed in accordance with Technical Requirement R3
- bitumen sheet to BS 6398
- proprietary materials assessed in accordance with Technical Requirement R3.

Cavity trays

Cavity trays should be provided at all interruptions to the cavity (eg window and door openings and air bricks) and abutments unless otherwise protected (eg by overhanging eaves) or alternative means of protection are provided (eg profiled metal flashings) such as part of a proprietary cladding system.

Clause 6.1.17 contains further guidance on the installation of cavity trays in masonry cladding.

The following materials are acceptable for use as cavity trays:

- plastic and rubber to BS EN 14909 and hold satisfactory assessment by an appropriate independent technical approval's authority accepted by NHBC
- proprietary materials as part of a cladding system holding satisfactory assessment by an appropriate independent technical approvals authority accepted by NHBC.

11.2.8.4 Junctions between adjoining units

At junctions between closed panel systems or between closed panel systems and surrounding construction, particularly where they incorporate factory installed external claddings, consideration should be given to:

- providing suitable access to seal laps of breather membranes and AVCLs and achieve minimum vertical and horizontal laps
- providing suitable access to adequately link DPCs and DPMs in the substructure
- use of appropriate tapes and sealant (but not solely rely on sealant) in accordance with the design and the manufacturer's recommendations
- design of suitable cladding joints in accordance with the manufacturer's recommendations
- interaction of cavity barriers and cladding joints
- use of damp proofing materials which are compatible with adjoining components.

Connections between closed panel systems and between closed panel systems and surrounding construction should be designed to avoid the risk of fixing through and thus puncturing or damaging AVCLs or breather membranes.

11.2.9 Insulation

Also see: Chapters 6.2 and 6.10

Insulation shall be suitable for the intended use, correctly installed, and be of a suitable material and thickness to comply with Building Regulations and reduce the risk of surface and interstitial condensation.

Insulation should be:

- in accordance with the design
- installed correctly to minimise the risk of thermal bridging, surface, and interstitial condensation
- installed in accordance with the manufacturer's recommendations.

The System Manual and design should include control measures to mitigate risk of slump of non-rigid insulation during transport and site installation.

Where insulation is to be installed to the external/cavity face of the frame, workmanship and tolerances of external walls, particularly at panel joints, should be maintained to minimise the risk of:

- reducing the width of clear cavities
- gaps between insulation boards
- ledges between insulation boards forming moisture traps.

Closed panel timber frame

Insulation to closed panel timber frame walls should be in accordance with Clause 6.2.15.

Structural insulated panels (SIPs)

Insulation to SIPs should be assessed as part of current certification by an appropriate independent technical approvals authority accepted by NHBC, as an integral part of the wall system.

Closed panel light steel frame

Insulation to closed panel light steel frame walls should be in accordance with Clause 6.10.17.

11.2.10 Junctions and interfaces

Also see: Chapters 6.2 and 6.10

Junctions and interfaces shall be suitably detailed, built to appropriate tolerances and provide satisfactory performance.

The use of closed panel systems, particularly where finished linings or claddings are installed may introduce junctions and interfaces between adjoining units that are not common in traditional construction.

The junctions of panels should be designed with appropriate tolerances to avoid excessive deviation:

- to external faces of adjacent panels, which may impact cavity widths, installation of insulation and cladding as well as performance of cavity barriers or fire-stopping
- to internal faces of adjacent panels, which may impact continuity of acoustic or fire-resisting linings or installation and fit of surrounding construction (eg staircases).

The manufacturer and designer should consider:

- guidance on jointing methods for structures, claddings, openings, and services passing through building elements given in BS 6093
- undertaking of mock-ups or trials to ensure satisfactory fit and tolerances can be achieved.

Closed panel timber frame

When fixing closed panel timber frame walls to the substructure, they should be installed in accordance with the manufacturer's design and Clause 6.2.4 and 6.2.5.

Closed panel light steel frame

When fixing closed panel light steel frame walls to the substructure, they should be installed in accordance with the manufacturer's design and Clause 6.10.10.

Floor cassettes

The design should clearly specify where connections are required to provide lateral restraint or robustness at floor to wall junctions. Installation instructions should be given in the System Manual and Installation Manual. Where floor cassettes incorporate permanent floor decking, care should be taken to design cassette junctions at thresholds or intermediate walls to minimise large joints in open rooms.

Adjoining cassettes should be securely fixed to ensure structural continuity and to avoid differential deflection in accordance with the manufacturer's design.

Junctions between decking to adjoining floor cassettes should be designed to achieve necessary tolerances to allow installation of floor coverings. Interfaces of decking may either be designed as a butt joint or by using a transition piece to accommodate minor tolerances between decking finishes.

Cassette junctions should:

- have a nominal 3mm gap at decking joints
- be kept clear of debris
- filled with an appropriate gap filler or covered with a cover strip
- not exceed 2mm level difference between floor decking at any position.

Foundations

Foundations should be installed to tolerances in accordance with the System Manual. The foundation tolerances should consider:

- level of foundation
- level between foundation and substructure brickwork
- straightness of foundations
- squareness of foundations.
- dimensional tolerance

11.2.11 Cladding

Also see: Chapters 6.1, 6.2, 6.9, 6.10 and 9.1

External claddings shall be suitable for their intended purpose, have suitable junctions and interfaces to resist the penetration of water and wind, be suitably durable and have an acceptable finished appearance. Issues to be taken into account include:

- 1) junctions and interfaces between cladding types and adjoining units
- 2) movement
- 3) continuity of insulation, breather membranes and AVCLs
- 4) tolerances
- 5) finished appearance.

Masonry external cladding should be in accordance with Chapter 6.1 External masonry walls.

Lightweight external claddings, whether factory or site installed, should be:

- in accordance with Chapter 6.9 Curtain walling and cladding
- compatible with the framing system
- supported by systems assessed in accordance with Technical Requirement R3 which ensure that cladding design loads are effectively and safely transferred to the building structure.

Further guidance on render onto board backgrounds can be found in Clause 6.11.8.

The design and construction of cladding to external walls should consider:

- cavity drainage
- differential movement
- restraint
- performance in relation to fire
- durability.

Closed panel timber frame and structural insulated panels (SIPs)

Further guidance on the use of masonry and lightweight claddings with closed panel timber frame and SIP walls can be found in Chapter 6.2 External timber framed walls.

Closed panel light steel frame

Further guidance on the use of masonry and lightweight claddings with closed panel light steel frame walls can be found in Chapter 6.10 Light steel framed walls and floors.

11.2.11.1 Junctions and interfaces

Junctions and interfaces, including those between factory installed lightweight cladding systems to adjoining panels, and those between lightweight cladding systems and other elements of the building, should be carefully designed and detailed to be weather resistant, and prevent moisture reaching parts of the wall it could adversely affect.

The design should take account of:

- differing profile characteristics
- movement
- design of suitable interfaces between differing cladding types
- tolerances and deviation
- the erection sequence.

For lightweight cladding finishes applied to an insulation backing, the use of small infill pieces at panel junctions or differing types of backing insulation (eg to form cavity barriers or fire-stopping at compartment lines) should be detailed in accordance with the manufacturer's recommendations and within the scope of certification by an independent technical approvals authority acceptable to NHBC.

11.2.11.2 Movement

Movement joints to masonry cladding should be in accordance with Clause 6.1.3. Refer to Clause 6.2.8 for further guidance on accommodating movement in masonry cladding to timber frame structures, and Clause 6.10.20 for masonry cladding to light steel frame structures.

Lightweight claddings

Where lightweight or self-supporting cladding is used movement joints should be provided where required by the design.

Movement joints should be:

- formed in accordance with the cladding system manufacturers recommendations
- positioned to accommodate calculated movement
- continued through the depth of the cladding.

Accommodation of differential movement should be made at floor zones between lightweight cladding.

11.2.11.3 Continuity of insulation, breather membranes and AVCLs

Junctions and interfaces of adjoining panels or panels with surrounding construction should be carefully designed and detailed to ensure continuity of insulation, breather membranes and AVCLs.

The design should:

- ensure adequate laps of membranes or provision for a suitable method of sealing in accordance with the manufacturer's recommendations
- make allowance for secure fixing of insulation, including at panel junctions, to the support frame or wall.

11.2.11.4 Tolerances

Where factory installed lightweight claddings extend to the edges of panels, the cladding interfaces should meet the following tolerances unless specified otherwise by the design:

- be adequately straight in elevation, with a maximum $\pm 6\text{mm}$ deviation from the nominal design width in any unit edge width or height up to 3m (see Figure 1)
- a maximum of 5mm from plumb or level in the overall interface joint between units (see Figure 2)
- a maximum deviation of 6mm in plan or section between faces of adjoining units (see Figure 3)
- a maximum deviation of 6mm in elevation between in-line edges across a transverse or cruciform interface joint (see Figure 4).

Figure 1: Straightness of interface joint widths

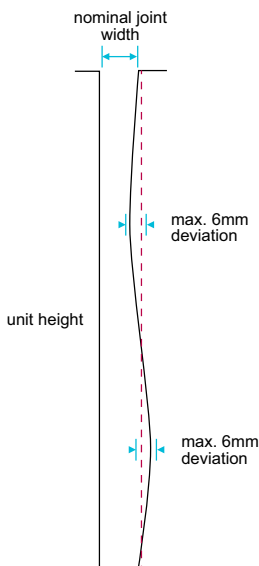

Figure 2: Taper of interface joints

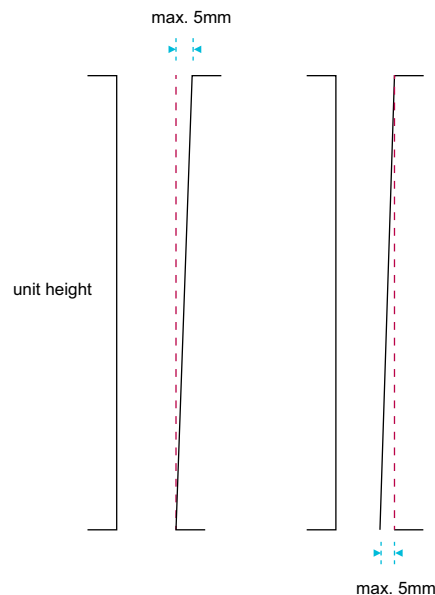

Figure 3: Offset of cladding faces

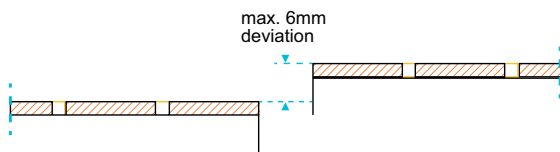
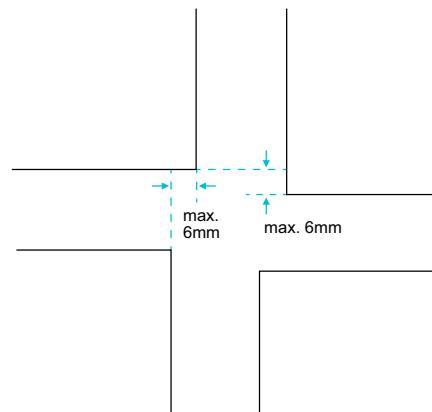

Figure 4: Accuracy of cruciform interface joints



11.2.11.5 Finished appearance

Tolerances and finishes for factory installed external claddings should be in accordance with Chapter 9.1 A consistent approach to finishes.

Brick slip cladding

Factory installed brick slip claddings should be set out to co-ordinate with adjacent panels and surrounding construction to avoid:

- cutting of brick slips, particularly in the storey heights, at corners, around openings, and at panel edges except when it is essential
- irregular or broken bonds of brick finishes, particularly at openings
- small cuts of brick finishes
- broken bond and out of line joints at junctions of panel and junctions with surrounding construction (eg substructure brickwork).

Care should be taken to ensure the finish specification of mortar used for site installed brickwork is the same as used for factory installed brick slip claddings to avoid variation in the texture, finish, and colour.

Weatherboard cladding

Factory installed weatherboard cladding should be set out to co-ordinate with adjacent panels and surrounding construction to avoid:

- cutting and notching cladding boards around window and door openings
- misaligned cladding boards at panel junctions.

11.2.12 Doors, windows, and glazing

Also see: Chapter 6.7

Doors, windows, and glazing shall comply with the Technical Requirements and be designed and specified to ensure adequate in-service performance.

Doors, windows, and glazing should be designed, specified, and installed in accordance with Chapter 6.7 Doors, windows and glazing.

The specification of fixings for doors and windows should be adequate to resist the effects of vibration and loads imposed during storage, transport and installation.

Adequate protection against damage should be provided to factory installed doors and windows, particularly where protruding from the face of the panel.

11.2.13 Air and vapour control layers

Air and vapour control layers shall be designed and installed correctly to restrict the passage of water from within the home to the structural frame.

A high resistance air and vapour control layer should be provided, unless a condensation risk analysis shows that it is not necessary, and the air and vapour control function is being provided by another solution compliant with NHBC Technical Requirements. Modelling where appropriate should be undertaken in accordance with BS EN ISO 13788 or BS EN 15026. The following boundary conditions should be used for the purposes of calculation to BS EN ISO 13788:

- at 21°C internally
- at -2°C externally
- >60% internal RH.

Where they are provided, AVCLs should be:

- sealed around service penetrations
- 500g polyethylene sheet, vapour control plasterboard, or material assessed in accordance with Technical Requirement R3
- in accordance with the design
- overlapping the base rail
- fixed on the warm side of the wall insulation and frame
- placed to cover the external wall, including base rails, head rails, studs, lintels, and window reveals
- taped or sealed in accordance with the manufacturer's recommendations and punctures made good.

Air and vapour control layers should be:

- stapled at 250mm centres to the top and bottom of the frame, at laps and around openings to closed panel timber frame
- fixed with double-sided tape or adhesive as a temporary fixing before the wall board is fixed to closed panel light steel frames.

Joints in air and vapour control membranes should:

- have 100mm minimum laps
- be located on studs or noggings.

Where vapour control plasterboard is used:

- joints between sheets should be positioned on studs or noggings
- joints should be filled, taped, and finished
- care should be taken not to displace the vapour control material when cutting vapour control plasterboard.

Where internal linings or sheathing boards are factory installed to panelised units, provision should be made to allow adequate access to achieve correct lapping and sealing of vapour control layers at junctions when installed in the final position on site.

Multiple layers of AVCL-type material through the thickness of the element should be avoided, except where condensation risk analysis shows it to be acceptable.

Closed panel timber frame and structural insulated panels (SIPs)

For closed panel timber frame systems and SIPs, where they incorporate structural timber, all structural timber elements (including the OSB of the SIP, if applicable) should have a moisture content of less than 20% before any internal AVCLs, insulation or plasterboard linings are installed.

11.2.14 Breather membranes

Breather membranes shall be correctly installed to protect the sheathing and frame from external moisture, and capable of allowing vapour to pass into the cavity.

Breather membranes should be:

- vapour resistant to less than 0.6MNs/g (0.12 Sd) when tested in accordance with BS EN ISO 12572 using the set of conditions C and using five test specimens
- at least Class W2 to BS EN 13859-2 with no water leakage during testing. In areas of very severe exposure (see Clause 6.1.6 for classification of exposure zones) or where liquid water penetration of the cladding is anticipated, for example open-jointed cladding, Class W1 should be used. When open-jointed claddings are used or the membrane likely to be left exposed during construction for a duration longer than normally to be expected (also see the membrane manufacturers recommendations on exposure times), performance should be based on artificial aged behaviour in accordance with BS EN 13859-2. Where a vented and ventilated cavity with full rainscreen and no gaps, for example masonry or rendered board claddings, are used, performance should be based on artificial aged behaviour in accordance with BS EN 13111
- self-extinguishing
- fixed so that vertical joints are staggered where possible, and at regular intervals, to prevent damage by wind
- installed so that each joint is protected, and moisture drains outwards
- lapped so that upper layers are over lower layers to ensure rain runs away from the sheathing
- lapped to a minimum of 100mm at horizontal joints and a minimum of 150mm at vertical joints
- fixed at a maximum spacing of 600mm horizontally and 300mm vertically
- fixed at a maximum spacing of 150mm around openings
- marked with stud positions for wall tie fixing
- applied using austenitic stainless-steel fixings
- repaired or replaced before proceeding with the cladding, if damaged
- durable and adequately strong when wet, to resist site damage
- capable of resisting water penetration.

For panelised systems without studs such as SIPs, fixings to the breather membrane should be at regular centres and suitably spaced at openings and panel edges.

Closed panel light steel frame

Breathable membranes should be used to protect sheathing boards and insulation. Breather membranes may be omitted where water resistant insulation boards with taped joints are used. Tape should be of a type recommended by the insulation manufacturer, breathable to allow water vapour to move freely and resist water penetration. Suitable taping should be applied at the lintel interfaces and other penetrations to direct water outside.

11.2.15 Sheathing boards

Also see: Chapters 6.2 and 6.10

Sheathing boards shall be durable and suitable for their intended purpose.

Sheathing boards should be:

- of a suitable strength and quality
- compatible with the frame
- attached using suitably specified and durable fixings.

Sheathing boards contribute to many functions critical to the performance of the system and building and cannot be easily replaced, so should comply with Technical Requirement R3.

Closed panel timber frame

Sheathing boards to closed panel timber frame walls should be in accordance with Clause 6.2.7.

Closed panel light steel frame

Sheathing boards should be appropriate for the exposure of the building and suitable for use in humid conditions.

Sheathing boards to closed panel light steel frame walls should be in accordance with Clause 6.10.20.

11.2.16 Wall ties

Wall ties and fixings shall adequately connect the cladding to the frame.

Wall ties and their fixings should be:

- compliant with BS EN 845-1
- fixed to studs and not the sheathing
- in accordance with and of the type specified in the design
- of austenitic stainless steel or assessed in accordance with Technical Requirement R3
- kept clean and free from mortar droppings
- inclined away from the sheathing so that the slope is maintained following differential movement
- capable of accommodating differential movement
- installed at a minimum density of 3.7 ties/m² for masonry cladding, eg spaced at a maximum of 600mm horizontally and 450mm vertically
- spaced at jambs of openings and at movement joints at a maximum of 300mm vertically and within 225mm of the masonry reveal or movement joint; additional studs may be needed
- spaced within 225mm of the top of the wall, including at gables.

Structural insulated panels (SIPs)

Where wall ties are fixed directly to the outer sheathing layer, screw fixings should be used. The pull-out strength of screw fixings should be:

- tested, or
- designed in accordance with relevant standards.

11.2.17 Services

Also see: Chapters 6.2 and 6.10

Internal services shall not adversely affect the stability or performance of the panel and be adequately protected from damage.

Service mains and service outlets should be:

- designed to ensure the fire resistance of walls and floors is not impaired
- designed to ensure that the required sound insulation of walls and floors is maintained
- installed in accordance with the design
- on the warm side of the insulation
- designed to accommodate differential movement where required.

Closed panel timber frame

Services to closed panel timber frame walls should be in accordance with Clause 6.2.9.

Structural insulated panels (SIPs)

Services passing through SIPs should not adversely affect the fire performance of the building. Issues to be taken into account include:

- suitable detailing of services passing through panels
- location and type of firestops to be used
- integrity of walls and floors.

Where holes are required to accommodate services, this should only be carried out in accordance with the manufacturer's recommendations or be designed by an engineer in accordance with Technical Requirement R5.

When installing services to SIPs, they should:

- be planned in advance so that ducts and conduits are provided
- not be chased into the core of the panel
- be installed in such a way to avoid cutting, igniting, or damaging the panel
- have additional engineered designed support for heavy loads from central heating and ventilation systems, or kitchen appliances.

Closed panel light steel frame

Services to closed panel steel frame walls should be in accordance with Clause 6.10.22.

11.2.18 Further information

- *Structural Timber Association — Moisture management strategy*



Chapter 11.3



Volumetric systems

This chapter gives guidance on meeting the Technical Requirements for volumetric systems used to form homes where the height of the top floor above ground does not exceed 18m.

11.3.1	Compliance	03
11.3.2	Provision of information	03
11.3.3	Structural design	04
11.3.4	Structural design checking and certification	05
11.3.5	Behaviour in relation to fire	05
11.3.6	Acoustic performance	07
11.3.7	Differential movement	07
11.3.8	Protection from moisture	08
11.3.9	Insulation	10
11.3.10	Junctions and interfaces	11
11.3.11	Cladding	11
11.3.12	Doors, windows, and glazing	14
11.3.13	Staircases	14
11.3.14	Air and vapour control layers	15
11.3.15	Breather membranes	16
11.3.16	Sheathing boards	16
11.3.17	Wall ties	17
11.3.18	Services	17
11.3.19	Further information	18

Figure reference table

Figure Reference Table 11.3

Fig No	Title/Description	Clause	Page
Figure 1	Straightness of interface joint widths	11.3.11.4	13
Figure 2	Taper of interface joints	11.3.11.4	13
Figure 3	Offset of cladding faces	11.3.11.4	13
Figure 4	Accuracy of cruciform interface joints	11.3.11.4	13

Introduction

This chapter provides guidance for volumetric systems used to form homes where the height of the top floor above ground does not exceed 18m.

The guidance in this chapter does not apply to volumetric roof systems or pre-manufactured structural components made of mass engineered timber.

This chapter should be used in conjunction with Chapter 11.1 MMC systems: general requirements. This chapter seeks to focus on areas of guidance that are unique to the system type and method of construction employed, giving references to complimentary existing guidance provided elsewhere in the Standards where relevant.

There is a strong link to all chapters in Part 6 of the Standards, particularly Chapters 6.2 and 6.10.

The term 'Modern Methods of Construction (MMC)' is very broad and covers a wide range of differing offsite manufactured systems and onsite construction techniques.

MMC types have been categorised and defined in the MHCLG Joint Working Group 'MMC Definition Framework', see Chapter 11.1 MMC systems: general requirements. The scope of the guidance in this chapter will cover volumetric systems that generally fall under Category 1 under the 'MMC Definition Framework' and as defined below:

Volumetric

Three-dimensional structural volumetric units fabricated offsite in a factory environment used to form all or part of the basic structure of a building. Volumetric units may incorporate varying degrees of offsite fabrication and finish, including internal and external linings, external claddings, windows and doors, internal finishes, concealed insulation, membranes, internal services, internal fixtures and fittings and fire-stopping.

Volumetric units can be used in varying configurations to form the entire structure of the home or be supported by surrounding construction. Units can be manufactured in varying structural forms and be formed from timber, concrete, steel or light gauge steel or a combination of those materials.

Definitions for this chapter

Cavity	A space enclosed by elements of a building which may either be the space between the cladding system and the backing wall or the space between building elements such as volumetric units. The external wall cavity should be adequately drained, and ventilated where required.
Cavity barrier	A construction within a cavity, other than a smoke curtain, to perform either of the following functions: <ul style="list-style-type: none"> • close a cavity to stop smoke or flame entering • restrict the movement of smoke or flame within a cavity.
Factory installed	An element of the construction that is placed, positioned, fitted or secured in, on or as part of the unit as part of the factory construction process.
Fire-stopping	A seal provided to close an imperfection of fit or design tolerance between elements or components, to restrict the spread of fire and smoke.
Installation Manual	Detailed installation guidance and information for the system compiled by the system manufacturer. The Installation Manual describes general instructions for storage and transport of the system, and procedures for on-site assembly and installation.
Interface	Interface either between similar or dissimilar envelope systems (eg at panel joints) or between envelope systems and other elements of the building (eg walls, roof, doors, and windows).
Junction	The point where components, including panels are joined with each other or with other elements of the building (eg supporting structure, roofs and foundations).
Manufacturer	The company which is responsible for the design and assembly of the volumetric system.
Non-standard components	Components that are assembled as part of the system but vary for individual projects. These may be windows, doors or services that may be built into the system.
Primary structural components	Elements of the structure designed to carry and transfer primary loads of the building, including self-weight, dead loads, and live loads.
Secondary structural components	Elements of the structure which do not play a wider role in the structure, but carry loads directly imposed on them (and transfer them to the primary structure) such as self-weight, wind loads, cladding and openings.
Standard components	Components that are assembled as part of the system and are common to all projects.
System	For the purposes of this chapter, this term refers to acceptable forms of volumetric systems.
System Manual	Detailed technical information on the system compiled by the system manufacturer. The System Manual describes the system, the declared performance of the system and evidence to support the declared performance.
Unit	A prefabricated building unit, manufactured offsite as a structural or non-structural assembly in three-dimensional or flat panel format used as part of a system to form the superstructure of a building.
Volumetric	Three-dimensional structural units which are commonly stacked to form a building. Volumetric units may incorporate varying degrees of off-site fabrication and finish, including internal and external linings, external claddings, windows and doors, internal finishes, concealed insulation, membranes, internal services, internal fixtures and fittings and fire-stopping.

11.3.1 Compliance

Also see: Chapters 2.1 and 11.1

Volumetric systems shall comply with the Technical Requirements.

Volumetric systems that comply with the guidance in this chapter and associated chapters will generally be acceptable. This chapter should be used in conjunction with guidance in Chapter 11.1 MMC Systems: general requirements.

As many components of volumetric systems cannot be inspected on site, they should be treated as a building system as defined in Chapter 2.1, Requirement R3 and subject to assessment by an independent technical approvals authority or assessed under the NHBC Accepts service; www.nhbc.co.uk/accepts.

11.3.2 Provision of information

Also see: Chapter 11.1

Designs and specifications shall be produced in a clearly understandable format, include all relevant information, and be distributed to all appropriate personnel.

Design, specification, and installation information should be issued to site supervisors, relevant specialist subcontractors and suppliers, and be made available on site to enable work to be carried out in accordance with the design. This should include:

- a System Manual (see Clause 11.1.3)
- a system Installation Manual (see Clause 11.1.9).
- clear, coordinated and fully detailed drawings providing sufficient information for construction and installation of the system

Refer to Chapter 11.1 MMC Systems: general requirements for further guidance.

11.3.3 Structural design

Also see: Chapters 3.1, 3.3, 6.2, 6.5 and 6.10

Volumetric systems shall be designed to support and transfer loads to foundations and supporting construction safely and without undue movement and shall have adequate resistance to loads imposed during manufacture, transportation, and installation. Issues to be taken into account include:

- 1) overall stability
- 2) unit connections
- 3) temporary loads
- 4) durability.

The structural design of the building should ensure adequate resistance to loadings in accordance with either the relevant Eurocode parts and their corresponding National Annexes relevant to the materials used to form the structural frame of the volumetric unit.

Where necessary, supplementary industry guidance should be followed where permitted by the relevant Eurocode and corresponding National Annex.

The design data may be supplemented with appropriate values derived from structural tests, acceptable to NHBC, where permitted by the relevant Eurocode and corresponding National Annex.

11.3.3.1 Overall stability

The building comprising volumetric units should be capable of supporting the specified loadings with adequate safety against structural collapse, inadmissible deformations, vibration, and disproportionate collapse.

Each unit should be framed in order to support itself fully and safely, by either:

- being designed as a rigid frame, or
- additional bracing or sheathing.

Overall stability of the building should be provided by either:

- the fully braced volumetric units, or
- connection to an independent bracing system such as a building core, shear walls and/or stability frame/s.

Design of a completed building should account for the effect of discontinuities in any system providing overall stability, eg the interruption of diaphragms or shear walls between modules.

Where differential movement between the volumetric units and any supporting structure such as a building core is expected, this should be considered as part of the design.

11.3.3.2 Unit connections

Connections between volumetric units should be designed by a Structural Engineer in accordance with Technical Requirement R5.

The design of connections between units or between units and surrounding construction, typically in-situ, should be compatible and have sufficient strength to transfer the necessary design loads and stiffness to enable the connected units to behave as a complete structure.

Connections should be designed and installed to achieve the required structural performance, and:

- accommodate movement where required
- allow for tolerance and adjustment
- be designed to avoid the risk of damaging or compromising the functional performance of factory installed elements such as breather membranes, AVCLs and lining boards.

The design, System Manual, and Installation Manual should include details of:

- specification and limits for shimming or adjustment of connections
- design and specification of fixings
- sequencing of installation.

Volumetric units should be mechanically fastened to supporting slab or foundations and not rely wholly on frictional resistance to resist sliding.

11.3.3.3 Temporary loads

Structural design of the units should consider the loads imposed during manufacture, storage, lifting and transportation and provide sufficient stiffness or protection against inadmissible deformation or deflection. See also Clause 11.1.8.

Where required, the design should specify temporary bracing and/or additional support arrangements for large openings or weak points in the structure and clearly identify the conditions under which such works can be removed.

11.3.3.4 Durability

The durability of materials and components should be specified in accordance with Technical Requirement R3. Structural elements and components that cannot easily be repaired or replaced should be suitably durable for the environment to which they will be exposed.

Metal fasteners, connectors and other structural steel parts in the element should either be:

- inherently corrosion resistant, or
- protected against corrosion to provide the required design life for the expected exposure condition.

Reinforced concrete should be in accordance with Chapter 3.1 Concrete and its reinforcement.

Timber should have adequate natural durability or be preservative treated in accordance with Chapter 3.3 Timber preservation (natural solid timber).

Steelwork should have protective coating in accordance with Chapter 6.5 Steelwork.

Light steel frame should have corrosion protection in accordance with Chapter 6.10 Light steel framed walls and floors.

11.3.4 Structural design checking and certification

Contact us: operationssupport@nhbc.co.uk

Design of the superstructure shall be adequately checked by an appropriate NHBC registered volumetric frame certifier.

Homes with a volumetric frame superstructure require certification confirming that the design has been checked by an NHBC registered volumetric frame certifier.

The certifier should:

- be listed on NHBC's list of volumetric frame certifiers
- be a suitably qualified civil or structural engineer with relevant experience in volumetric construction
- not be the designer of the volumetric frame or be employed by the same practice
- check supporting details and calculations
- complete and sign a certificate confirming assessment of structural adequacy for each specific project
- provide the registered builder with the completed and signed certificate.

The registered builder should ensure that the completed certificate is available on site for inspection by NHBC.

Contact NHBC Standards, Innovation and Research via operationssupport@nhbc.co.uk.

- if you require contact details of volumetric frame certifiers, or
- to apply to become a volumetric frame certifier.

11.3.5 Behaviour in relation to fire

Volumetric systems shall have adequate fire resistance and resist the spread of fire and smoke in accordance with Building Regulations. Issues to be taken into account include:

- 1) cavity barriers and fire-stopping
- 2) services
- 3) fire resistance of the unit
- 4) movement.

Guidance within supporting documents to the Building Regulations should be fully considered in the design and construction of volumetric systems.

The design and System Manual should clearly define:

- the overall fire protection strategy of the system
- which elements of fire protection are either factory or site installed.

11.3.5.1 Cavity barriers and fire-stopping

The provision and installation of cavity barriers and fire-stopping should:

- be specified to accommodate design, manufacturing and installation tolerances
- be in accordance with the Building Regulations and the design
- be designed to accommodate ventilation or drainage paths
- be used in accordance with manufacturers recommendations
- account for movement in the frame.

Detailing and specification of cavity barriers and fire-stopping should be in accordance with the manufacturer's recommendations and supported with representative test evidence.

Moisture protection should be provided to horizontal and vertical cavity barriers.

Where cavity barriers or fire-stopping cannot be easily replaced they should be specified in accordance with the design life of the building.

Buildings incorporating volumetric units may have significant concealed cavities between units. The building design should consider appropriate subdivision of cavities at horizontal and vertical junctions of volumetric units and between volumetric units and surrounding construction. Fire-stopping should be provided where necessary at junctions, to complete lines of compartmentation.

Factory installed cavity barriers or fire-stopping may be damaged or dislodged during the transportation or installation of volumetric units on site. Manufacturers and installers should allow for suitable access to inspect and verify concealed cavity barriers and fire-stopping post-installation.

When providing cavity barriers and fire-stopping:

- fire-stopping should be specified and sized to accommodate dimensional and installation tolerances of the unit
- gaps between compartments should be sealed
- presence of temporary weather protection membranes should not affect the performance, and should be removed unless tested or approved by the design.

At compartment walls fire-stopping should be provided to seal any gaps between the underside of units and the tops of foundations or substructure walls.

11.3.5.2 Services

Only the services shown in the design should be installed in volumetric system floors and walls, and:

- service outlets should not impair the fire resistance of floors and walls
- service mains should not pass through separating wall cavities.

11.3.5.3 Fire resistance of the unit

All building elements should have adequate fire resistance in accordance with Building Regulations, supported with representative test evidence and supporting engineering assessments to appropriate standards.

The design should specify:

- whether primary structural members require individual encasement or are protected by fire-resistant linings to the wall, floor, or ceiling frame
- details of junctions of secondary attachments to the primary structural frame and how fire resistance is maintained
- details of service openings, voids, and penetrations
- details demonstrating that columns and beams, where provided, are protected on all sides for the full height or width, including connections to other structural members, and how protection is maintained where the members extend through a ceiling or floor voids.

Where units join together and continuous linings are required or where access points are left open to facilitate connections, internal fire-resisting linings should be:

- installed with minimum laps in accordance with manufacturer's recommendations, or
- in accordance with the design and supported with representative test evidence to appropriate standards.

11.3.5.4 Movement

Fire-stopping should be specified and designed to accommodate anticipated movement in the building structure.

Where units are connected to surrounding construction, differential vertical movement should be considered in the design and specification of suitable fire-stopping and cavity barriers.

Non-loadbearing infill walls within volumetric units should accommodate anticipated deflection within the primary frame in accordance with the design. Should these walls be fire resisting, detailing at the head should be such that performance in this regard is not compromised.

11.3.6 Acoustic performance

Also see: Chapters 6.3 and 6.4

Volumetric system walls and floors shall have adequate resistance to the passage of sound.

Separating walls and floors

Separating walls and floors should be in accordance with Building Regulations and the design. Care should be taken to avoid gaps:

- between mineral wool quilt or batts
- between internal lining board layers
- between cavity barriers
- around openings for services.

Walls and floors in volumetric units will commonly be of complex construction and independent test evidence of acoustic performance or assessment by a suitably qualified expert should be provided prior to construction and detailed in the System Manual. Values derived from partition manufacturers data may not be appropriate to determine the sound performance of the wall construction where additional structural elements are included in the wall, or the panel serves as an infill.

Bedrooms and rooms containing a WC

The construction of internal walls should comply with Building Regulations, including the recommended sound reduction between bedrooms and rooms that include a WC and:

- living rooms
- dining rooms
- studies
- bedrooms, except where the WC is an ensuite serving that bedroom.

Proprietary partitions

Proprietary partitions should be independently assessed or tested for 'sound transmission' performance in compliance with Technical Requirement R3.

Sound insulation of SVPs and soil pipes in floor voids

All soil pipes running horizontally through a floor void above or below a habitable room should be wrapped in at least 25mm of mineral wool (10kg/m³ min) and be adequately supported to avoid contact with the floor decking or ceiling.

Sound insulation should be provided to soil pipes passing through homes by an encased boxing, using lining materials (minimum 15kg/m²) and wrapping the pipe with a minimum 25mm of unfaced mineral fibre (10kg/m³ minimum). The insulation should be continued through the thickness of each sound-insulating floor).

11.3.7 Differential movement

Also see: Chapters 6.2 and 6.10

Buildings formed using volumetric systems shall account for differential movement between the frame and other building elements or supporting structures.

Where volumetric units connect to surrounding construction and differential vertical movement is expected, consideration should be given to:

- the design of joint details and accommodation of differing floor levels at thresholds, staircases and lift shaft enclosures
- service entries and risers
- design and provision of suitable weather resistant and durable joints
- interface of self-supporting cladding and cladding attached to the unit
- design of connection brackets, anchors, and ties to accommodate movement.

Timber frame volumetric

Where the primary structure of volumetric units is timber, it will shrink as the timber dries out, reducing the overall height. In some cases the expected shrinkage can be greater than that of traditional platform framed timber buildings due to the form of construction. The extent of the differential movement increases with the number of storeys, and the design should allow for differential movement between the volumetric units and other parts of the construction, including:

- door and window openings
- eaves and verges
- balconies (including Juliet balconies)
- service entries, risers and fixed vertical external services
- openings for drive throughs
- staircases and lift shaft enclosures (where they are not timber framed)
- the interface of the timber volumetric unit with any other construction at each floor level where cladding is fixed to the unit.

For timber frame volumetric structures the shrinkage and associated gap sizes to accommodate differential settlement should be subject to specialist calculation.

Where claddings are factory installed and supported by the volumetric unit, consideration should be given to interfaces with self-supporting cladding.

Refer to Clause 6.2.8 for guidance on how to accommodate differential movement in traditional platform timber frame construction.

Light steel frame volumetric

The design for differential movement in light steel frame volumetric structures should be in accordance with the System Manual. Also see Clauses 6.10.20 and 6.10.21.

11.3.8 Protection from moisture

Also see: Chapters 5.1, 6.1, 6.2, 6.10 and 11.1

Volumetric systems shall be adequately protected from the effects of moisture. Details of volumetric systems at low level shall fully consider the durability of materials, protection of the building from moisture ingress and condensation as a result of thermal bridging. Issues to be taken into account include:

- 1) cavities in external walls
- 2) protection at low level
- 3) DPCs, DPMs and cavity trays
- 4) junctions between adjoining units.

Guidance on temporary weather protection can be found in Clause 11.1.5. Guidance on moisture management strategies for structural timber buildings can be found in Structural Timber Association publication 'Moisture management strategy'.

11.3.8.1 Cavities in external walls

A clear cavity in accordance with Table 1 should be provided between the cladding and insulation.

Table 1: Minimum cavity widths

Cladding	Cavity width
Masonry	50mm
Render on board background	25mm
Vertical tile hanging ⁽¹⁾ where a breather membrane is provided and fixed to sheathing	Dependant on batten support layout and spacing ⁽¹⁾
Other cladding ⁽¹⁾	See Chapter 6.9 Curtain walling and cladding

Note

1. See Chapter 6.9 Curtain walling and cladding.

Cavities should be:

- drained (for light steel frame backing walls)
- extend at least 150mm below DPC
- drained and vented (for timber frame backing walls)
- be kept clean, free from obstructions and capable of draining freely.

Timber frame backing walls

Cavities to volumetric units with a timber frame backing wall should be in accordance with Clause 6.2.10.

Light steel frame backing walls

Cavities to volumetric units with a light steel frame backing wall should be in accordance with Clause 6.10.16.

11.3.8.2 Protection at low level

Timber frame walls

The lowest timber should be a minimum of 150mm above finished ground level. This may be reduced to 75mm in situations where the site is not subject to a high-water table or where the cavity will not have standing water.

DPCs should be installed below the sole plates of ground floor walls and internal partitions.

Where external ground levels are raised locally to accommodate accessible entrances, consideration should be given to the following:

- appropriate drainage installed along the perimeter or ground falling away from the building
- adjacent surface finishes which do not promote splashing
- additional cavity ventilation either side of raised ground levels
- use of a 'kerb' to raise level of timber frame elements.

Light steel frame walls and floors

The base rail of LSF should be kept a minimum of 150mm above the external ground level (or waterproofing layer of a flat roof, balcony, or terrace) and cavity fill.

DPCs should be installed underneath the full width of the lowest section of framing, eg all ground floor walls and internal partitions, to protect the steel from corrosion due to moisture.

Locally raised ground levels (up to the internal floor finish) to less than 15% of the external perimeter (of an individual building, eg row of terraced homes, apartment blocks and detached garages, measured on plan) to accommodate level thresholds can be accepted. The cavity should be kept clear and allow drainage. Wall insulation should overlap the base rail by a minimum of 150mm.

Where the base rail or lowest steel is less than 150mm above ground level:

- light steel frame should be in accordance with Clause 6.10.16b
- hot rolled steel components should have a factory-applied protective coating system in accordance with Clause 6.5.3.

11.3.8.3 DPCs, DPMs and cavity trays

Damp proofing should:

- be installed correctly to provide a physical barrier to the passage of water, and to ensure water is directed to the outside
- use only appropriate tapes and sealant (but not solely rely on sealant) in accordance with the design and manufacturer's recommendations
- use DPCs/DPMs where necessary, including junctions between systems and any other component or systems.

DPCs

The following materials are acceptable for use as DPCs:

Bitumen-based materials	BS 6398, BS EN 14967
Polyethylene (except as cavity trays in walls, below copings and in parapets)	BS 6515, BS EN 14909
Proprietary materials	Technical Requirement R3
Thermoplastics and Elastomers	BS EN 14909

DPMs

Where DPMs are required, they should be linked with any DPCs in the supporting structure, in order to provide continuous protection from moisture from the ground or through the supporting structure.

DPMs should be properly lapped in accordance with Chapter 5.1 Substructure and ground-bearing floors.

Suitable materials for DPMs include:

- 1,200-gauge (0.3mm) polythene sheet
- minimum 1,000-gauge (0.25) polythene sheet where assessed in accordance with Technical Requirement R3
- bitumen sheet to BS 6398
- proprietary materials assessed in accordance with Technical Requirement R3.

Cavity trays

Cavity trays should be provided at all interruptions to the cavity (eg window and door openings and air bricks) and abutments unless otherwise protected (eg by overhanging eaves) or alternative means of protection are provided (eg profiled metal flashings) such as part of a proprietary cladding system.

Clause 6.1.17 contains further guidance on the installation of cavity trays in masonry cladding.

The following materials are acceptable for use as cavity trays:

- plastic and rubber to BS EN 14909 and hold satisfactory assessment by an appropriate independent technical approval's authority accepted by NHBC
- proprietary materials as part of a cladding system holding satisfactory assessment by an appropriate independent technical approvals authority accepted by NHBC.

11.3.8.4 Junctions between adjoining units

At junctions of volumetric units or between volumetric units and surrounding construction, particularly where they incorporate factory installed external claddings, consideration should be given to:

- providing suitable access to install breather membranes and achieve minimum laps
- providing suitable access to adequately link DPCs and DPMs in the substructure
- use of appropriate tapes and sealant (but not solely rely on sealant) in accordance with the design and the manufacturer's recommendations
- design of suitable cladding joints in accordance with the manufacturer's recommendations
- interaction of cavity barriers and cladding joints
- use of damp proofing materials which are compatible with adjoining components.

Connections between volumetric units and between volumetric units and surrounding construction should be designed to avoid the risk of fixing through and thus puncturing or damaging AVCLs or breather membranes.

11.3.9 Insulation

Also see: Chapters 6.2 and 6.10

Insulation shall be suitable for the intended use, correctly installed, and be of a suitable material and thickness to comply with Building Regulations and reduce the risk of surface and interstitial condensation.

Insulation should be:

- in accordance with the design
- installed correctly to minimise the risk of thermal bridging, surface, and interstitial condensation
- installed in accordance with the manufacturer's recommendations.

The System Manual and design should include control measures to mitigate risk of slump of non-rigid insulation during transport and site installation.

Where insulation is to be installed to the external/cavity face of the frame, workmanship and tolerances of external walls, particularly at panel joints, should be maintained to minimise:

- reducing the width of clear cavities
- gaps between insulation boards
- ledges between insulation boards forming moisture traps.

Timber frame backing walls

Insulation to volumetric units with a timber frame backing wall should be in accordance with Clause 6.2.15.

Light steel frame backing walls

Insulation to volumetric units with a light steel frame backing wall should be in accordance with Clause 6.10.17.

11.3.10 Junctions and interfaces

Also see: Chapters 6.2 and 6.10

Junctions and interfaces shall be suitably detailed, built to appropriate tolerances and provide satisfactory performance.

The use of volumetric units, particularly where finished linings or claddings are installed will introduce junctions and interfaces between adjoining units that are not common in traditional construction.

The junctions of volumetric units should be designed with appropriate tolerances to avoid excessive deviation:

- to external faces of adjacent units, which may impact cavity widths, installation of insulation and cladding as well as performance of cavity barriers or fire-stopping
- to internal faces of adjacent units, which may impact continuity of acoustic or fire-resisting linings or installation and fit of surrounding construction (eg staircases).

Spatial tolerances are critical for the performance of joints, details, and interfaces. The design should:

- include dimensions and the permissible deviation clearly indicated in the System Manual and on relevant drawings
- allow for adjustability to accommodate the tolerances for manufactured units and range of deviation in site construction in the form of levelling bolts, bracket systems and detailing allowing horizontal and vertical adjustment.

The manufacturer and designer should consider:

- guidance on jointing methods for structures, claddings, openings, and services passing through building elements given in BS 6093
- undertaking of mock-ups or trials to ensure satisfactory fit and tolerances can be achieved.

Foundations

Foundations should be installed to tolerances in accordance with the System Manual. The foundation tolerances should consider:

- level of foundation
- straightness of foundations
- dimensional tolerance
- level between foundation and substructure brickwork
- squareness of foundations.

Floors

Interfaces of floors at unit junctions should be designed to achieve necessary tolerances to allow installation of floor coverings. Interfaces of floor decking may either be designed as a butt joint or by using a transition piece to accommodate minor tolerances between decking finishes.

Floor interfaces should:

- have a nominal 3mm gap at decking joints
- filled with an appropriate gap filler or covered with a cover strip
- be kept clear of debris
- not exceed 2mm level difference between floor decking at any position.

11.3.11 Cladding

Also see: Chapters 6.1, 6.2, 6.9, 6.10 and 9.1

External claddings shall be suitable for their intended purpose, have suitable junctions and interfaces to resist the penetration of water and wind, be suitably durable and have an acceptable finished appearance.

Issues to be taken into account include:

- 1) junctions and interfaces between cladding types and adjoining units
- 2) movement
- 3) continuity of insulation, breather membranes and AVCLs
- 4) tolerances
- 5) finished appearance.

Masonry external cladding should be in accordance with Chapter 6.1 External masonry walls.

Lightweight external claddings, whether factory or site installed, should be:

- in accordance with Chapter 6.9 Curtain walling and cladding
- compatible with the framing system
- supported by systems assessed in accordance with Technical Requirement R3 which ensure that cladding design loads are effectively and safely transferred to the building structure.

Further guidance on render onto board backgrounds can be found in Clause 6.11.8.

The design and construction of cladding to external walls should consider:

- durability
- cavity drainage
- differential movement
- restraint
- performance in relation to fire.

Timber frame backing walls

Further guidance on the use of masonry and lightweight claddings with timber frame walls can be found in Chapter 6.2 External timber framed walls.

Light steel frame backing walls

Further guidance on the use of masonry and lightweight claddings with light steel frame walls can be found in Chapter 6.10 Light steel framed walls and floors.

11.3.11.1 Junctions and interfaces

Junctions and interfaces, including those between factory installed lightweight cladding systems to adjoining units, and those between lightweight cladding systems and other elements of the building, should be carefully designed and detailed to be weather resistant, and prevent moisture reaching parts of the wall it could adversely affect.

The design should take account of:

- differing profile characteristics
- movement
- design of suitable interfaces between differing cladding types
- tolerances and deviation
- the erection sequence.

For lightweight cladding finishes applied to an insulation backing, the use of small infill pieces at unit junctions or differing types of backing insulation (eg to form cavity barriers or fire-stopping at compartment lines) should be detailed in accordance with the manufacturer's recommendations and within the scope of certification by an independent technical approvals authority acceptable to NHBC.

11.3.11.2 Movement

Movement joints to masonry cladding should be in accordance with Clause 6.1.3. Refer to Clause 6.2.8 for further guidance on accommodating movement in masonry cladding to timber frame structures, and Clause 6.10.20 for masonry cladding to light steel frame structures.

Lightweight claddings

Where lightweight or self-supporting cladding is used movement joints should be provided where required by the design.

Movement joints should be:

- formed in accordance with the cladding system manufacturers' recommendations
- positioned to accommodate calculated movement
- continued through the depth of the cladding.

Accommodation of differential movement should be made at floor zones between lightweight cladding.

11.3.11.3 Continuity of insulation, breather membranes and AVCLs

Junctions and interfaces of adjoining units or units with surrounding construction should be carefully designed and detailed to ensure continuity of insulation, breather membranes and AVCLs.

The design should:

- ensure adequate laps of membranes or provision for suitable method of sealing in accordance with manufacturer's recommendations
- make allowance for secure fixing of insulation, including at panel junctions, to the support frame or wall.

11.3.11.4 Tolerances

Where factory installed lightweight claddings extend to the edges of units, the cladding interfaces should meet the following tolerances unless specified otherwise by the design:

- be adequately straight in elevation, with a maximum $\pm 6\text{mm}$ deviation from nominal design width in any unit edge width or height up to 3m (see Figure 1)
- a maximum of 5mm from plumb or level in the overall interface joint between units (see Figure 2)
- a maximum deviation of 6mm in plan or section between faces of adjoining units (see Figure 3)
- a maximum deviation of 6mm in elevation between in-line edges across a transverse or cruciform interface joint (see Figure 4).

Figure 1: Straightness of interface joint widths

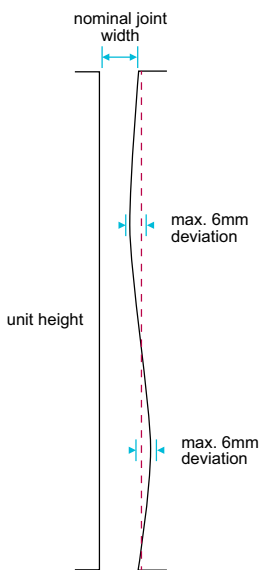

Figure 2: Taper of interface joints

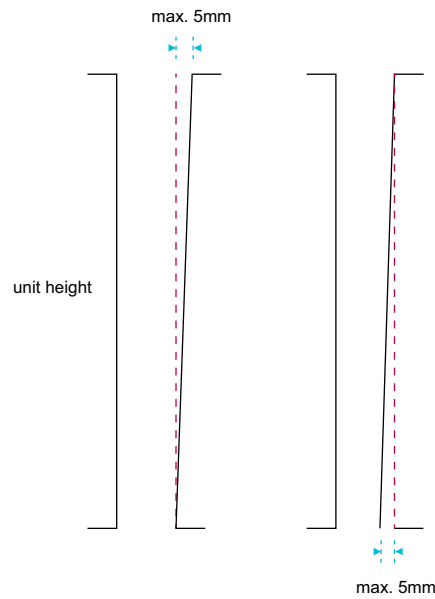

Figure 3: Offset of cladding faces

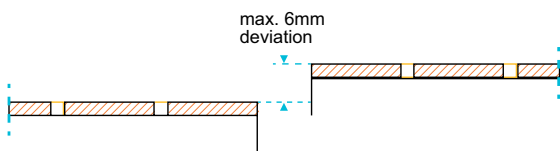
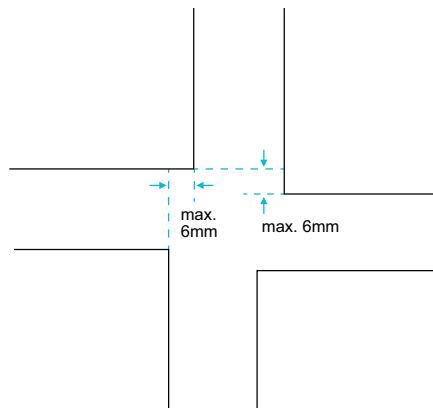

Figure 4: Accuracy of cruciform interface joints



11.3.11.5 Finished appearance

Tolerances and finishes for factory installed external claddings should be in accordance with Chapter 9.1 A consistent approach to finishes.

Brick slip cladding

Factory installed brick slip claddings should be set out to co-ordinate with adjacent units and surrounding construction to avoid:

- cutting of brick slips, particularly in the storey heights, at corners, around openings, and at panel edges except when it is essential
- irregular or broken bonds of brick finishes, particularly at openings
- small cuts of brick finishes
- broken bond and out of line joints at junctions of panel and junctions with surrounding construction (eg substructure brickwork).

Care should be taken to ensure the finish specification of mortar used for site installed brickwork is the same as used for factory installed brick slip claddings to avoid variation in the texture, finish, and colour.

Weatherboard cladding

Factory installed weatherboard cladding should be set out to co-ordinate with adjacent units and surrounding construction to avoid:

- cutting and notching cladding boards around window and door openings
- misaligned cladding boards at panel junctions.

11.3.12 Doors, windows, and glazing

Also see: Chapter 6.7

Doors, windows, and glazing shall comply with the Technical Requirements and be designed and specified to ensure adequate in-service performance.

Doors, windows, and glazing should be designed, specified, and installed in accordance with Chapter 6.7 Doors, windows and glazing.

The specification of fixings for doors and windows should be adequate to resist the effects of vibration and loads imposed during storage, transport and installation.

Adequate protection against damage should be provided to factory installed doors and windows, particularly where protruding from the face of the unit.

11.3.13 Staircases

Also see: Chapter 6.6

Staircases shall comply with the Technical Requirements and be designed to ensure adequate safety and performance.

Staircases should be designed, specified, and installed in accordance with Chapter 6.6 Staircases.

Wall linings should be continuous behind the string of staircases.

Fixing connections should be coordinated to ensure fire protection continuity and structural adequacy.

Where staircases are factory installed into volumetric units, consideration should be given to construction tolerances and the potential for differential vertical movement when designing connections to upper units. Landings should be framed to provide full support and solid fixings for the tops of flights, nosings, newels, apron linings, etc.

Suitable access should be provided to facilitate final installation of staircases and connection to upper units on site, including any necessary fixings or supports required.

The top nosing of staircases should be:

- level with the floor decking
- fixed firmly.

11.3.14 Air and vapour control layers

Air and vapour control layers shall be designed and installed correctly to restrict the passage of water from within the home to the structural frame.

Where they are provided, AVCLs should be:

- 500g polyethylene sheet, vapour control plasterboard, or material assessed in accordance with Technical Requirement R3
- in accordance with the design
- overlapping the base rail
- fixed on the warm side of the wall insulation and frame
- placed to cover the external wall, including base rails, head rails, studs, lintels, and window reveals
- taped or sealed in accordance with the manufacturer's recommendations and punctures made good
- sealed around service penetrations.

Air and vapour control layers should be:

- stapled at 250mm centres to the top and bottom of the frame, at laps and around openings to closed panel timber frame
- fixed with double-sided tape or adhesive as a temporary fixing before the wall board is fixed to closed panel light steel frame backing walls.

Joints in air and vapour control membranes should:

- have 100mm minimum laps
- be located on studs or noggings.

Where vapour control plasterboard is used:

- joints between sheets should be positioned on studs or noggings
- joints should be filled, taped, and finished
- care should be taken not to displace the vapour control material when cutting vapour control plasterboard.

The junctions of volumetric units, particularly where the junction includes back-to-back internal walls, should be carefully designed to ensure the continuity of air and vapour control layers.

Where internal linings are factory installed to volumetric units, provision should be made to allow adequate access to achieve correct lapping and sealing of air and vapour control layers at unit junctions when installed in the final position on site.

Light steel frame backing walls

A high resistance air and vapour control layer should be provided, unless a condensation risk analysis shows that it is not necessary, and the air and vapour control function is being provided by another solution compliant with NHBC Technical Requirements. Modelling where appropriate should be undertaken in accordance with BS EN ISO 13788 or BS EN 15026. The following boundary conditions should be used for the purposes of calculation to BS EN ISO 13788:

- at 21°C internally
- at -2°C externally
- >60% internal RH.

Multiple layers of AVCL-type material through the thickness of the element should be avoided, except where condensation risk analysis shows it to be acceptable.

11.3.15 Breather membranes

Breather membranes shall be correctly installed to protect the sheathing and frame from external moisture, and capable of allowing vapour to pass into the cavity.

Breather membranes should be:

- vapour resistant to less than 0.6MNs/g (0.12 Sd) when tested in accordance with BS EN ISO 12572 using the set of conditions C and using five test specimens
- at least Class W2 to BS EN 13859-2 with no water leakage during testing. In areas of very severe exposure (see Clause 6.1.6 for classification of exposure zones) or where liquid water penetration of the cladding is anticipated, for example open-jointed cladding, Class W1 should be used. When open-jointed claddings are used or the membrane likely to be left exposed during construction for a duration longer than normally to be expected (also see the membrane manufacturers recommendations on exposure times), performance should be based on artificial aged behaviour in accordance with BS EN 13859-2. Where a vented and ventilated cavity with full rainscreen and no gaps, for example masonry or rendered board claddings, are used, performance should be based on artificial aged behaviour in accordance with BS EN 13111
- self-extinguishing
- fixed so that vertical joints are staggered where possible, and at regular intervals, to prevent damage by wind
- installed so that each joint is protected, and moisture drains outwards
- lapped so that upper layers are over lower layers to ensure rain runs away from the sheathing
- lapped to a minimum of 100mm at horizontal joints and a minimum of 150mm at vertical joints
- fixed at a maximum spacing of 600mm horizontally and 300mm vertically
- fixed at a maximum spacing of 150mm around openings
- marked with stud positions for wall tie fixing
- applied using austenitic stainless-steel fixings
- repaired or replaced before proceeding with the cladding, if damaged
- durable and adequately strong when wet, to resist site damage
- capable of resisting water penetration.

Only tapes and sealants in accordance with the design and the manufacturer's recommendations should be used for sealing of membrane joints.

Light steel frame backing walls

Breathable membranes should be used to protect sheathing boards and insulation. Breather membranes may be omitted where water resistant insulation boards with taped joints are used. Tape should be of a type recommended by the insulation manufacturer, breathable to allow water vapour to move freely and resist water penetration. Suitable taping should be applied at the lintel interfaces and other penetrations to direct water outside.

11.3.16 Sheathing boards

Also see: Chapters 6.2 and 6.10

Sheathing boards shall be durable and suitable for their intended purpose.

Where they are required, sheathing boards should be:

- of a suitable strength and quality
- attached using suitably specified and durable fixings.
- compatible with the frame

Sheathing boards contribute to many functions critical to the performance of the system and building and cannot be easily replaced, so should comply with Technical Requirement R3.

Timber frame backing walls

Sheathing boards to volumetric units with a timber frame backing wall should be in accordance with Clause 6.2.7.

Light steel frame backing walls

Sheathing boards should be appropriate for the exposure of the building and suitable for use in humid conditions.

Sheathing boards to volumetric units with a light steel frame backing wall should be in accordance with Clause 6.10.20.

11.3.17 Wall ties

Wall ties and fixings shall adequately connect the cladding to the frame.

Wall ties and their fixings should be:

- compliant with BS EN 845-1
- fixed to studs and not the sheathing
- in accordance with and of the type specified in the design
- of austenitic stainless steel or assessed in accordance with Technical Requirement R3
- kept clean and free from mortar droppings
- inclined away from the sheathing so that the slope is maintained following differential movement
- capable of accommodating differential movement
- installed at a minimum density of 3.7 ties/m² for masonry cladding, eg spaced at a maximum of 600mm horizontally and 450mm vertically
- spaced at jambs of openings and at movement joints at a maximum of 300mm vertically and within 225mm of the masonry reveal or movement joint; additional studs may be needed
- spaced within 225mm of the top of the wall, including at gables.

11.3.18 Services

Also see: Chapters 6.2, 6.10 and 8.1 to 8.6

Internal services shall comply with the Technical Requirements and be in accordance with statutory requirements. Issues to be taken into account include:

- 1) installation
- 2) recording of factory testing and commissioning
- 3) access for site connections, inspections, and commissioning.

All service installations should be designed and installed in accordance with Part 8 Services.

The design and System Manual should clearly define:

- how design, manufacturing and installation tolerances are accommodated
- which services are factory installed and which are site installed
- designer responsibilities for factory installed and site installed elements and overall coordination.

Service mains and service outlets should be:

- designed to ensure the fire resistance of walls and floors is not impaired
- designed to ensure that the required sound insulation of walls and floors is maintained
- installed in accordance with the design
- on the warm side of the insulation
- designed to accommodate differential movement where required.

Careful positioning of service pop-ups and entry points is required to align with service entry points and factory installed services to volumetric units. A pre-installation survey should be undertaken prior to installation of units.

11.3.18.1 Installation

Prefabricated wiring systems should be tested and installed in accordance with BS 8488. The manufacturer should provide details of whether any or all of the connectors within the prefabricated wiring system should be accessible for inspection, testing and maintenance.

Timber frame walls and floors

Services installed in volumetric units with timber frame walls and floors should be in accordance with Chapter 6.2 External timber frame walls and Chapter 6.4 Timber and concrete upper floors.

Light steel frame walls and floors

Services installed in volumetric units with light steel frame walls and floors should be in accordance with Clause 6.10.22.

11.3.18.2 Factory testing and commissioning

The method of testing and commissioning of factory installed services should be detailed in the System Manual.

Pressure testing of factory installed water supply, gas supply, heating and waste pipework should be undertaken where practicable. Exposed ends of all pipework should be sealed to prevent contamination and protected to prevent damage.

Appropriate performance and safety testing should be undertaken to factory installed prefabricated wiring systems in accordance with BS 8488.

Written records should be provided for testing undertaken to factory installed services and included in system verification documentation.

11.3.18.3 Access

Where access is required to connect service mains through walls or floors, a suitable method should be detailed in the System Manual for making good the access point in accordance with the design to maintain the fire, sound, air, thermal, and moisture resistance of the structure.

Consideration should be given to:

- providing adequately located and sized access points to install, test and commission service connections on site
- provision of suitable information in the handover file where access points are to be permanently sealed (such as behind a tiled wall), to allow future users access in the event of a fault or for routine maintenance.

Consideration should be given to providing access for inspection or maintenance or a leak detection system where concealed riser voids contain water supply pipework.

11.3.19 Further information

- *Structural Timber Association — Moisture management strategy*